

H. JAMES.  
Liquid Measure.

No. 28,581.

Patented June 5, 1860.

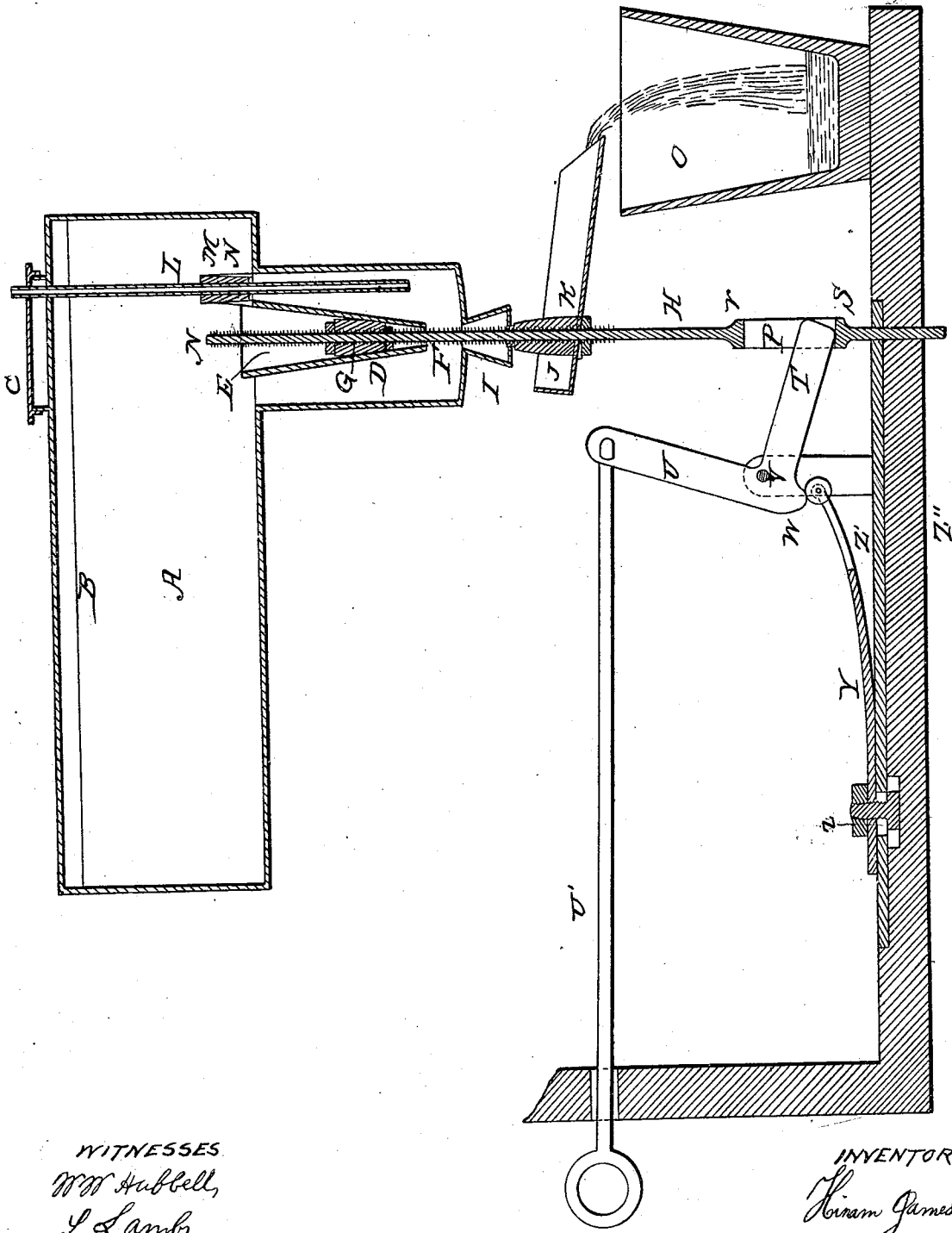

WITNESSES  
W. W. Hubbell,  
J. Lamb

INVENTOR  
Hiram James

# UNITED STATES PATENT OFFICE.

HIRAM JAMES, OF BARCLAY, ILLINOIS.

## APPARATUS FOR MEASURING LIQUIDS.

Specification of Letters Patent No. 28,581, dated June 5, 1860.

*To all whom it may concern:*

Be it known that I, HIRAM JAMES, of the town of Barclay, Ogle county, State of Illinois, have invented a new and useful Improvement in Apparatus for Measuring Liquors; and I hereby declare the following to be a full, clear, and exact description thereof, reference being had to the annexed drawing, making part hereof, exhibiting a section of the apparatus.

The nature of my invention consists in a combination of means hereinafter described, by which any desired quantity of liquor may be measured off, in the same measure; and in combination of means also described, by which the liquor may be at one operation measured, drawn off into a glass or other receiver, without allowing a continuous stream to pass through the measure.

A, is a reservoir containing the liquor to be measured from; B representing the height of the liquor in it; C is the receiving mouth of the reservoir, D, is the measuring chamber below the reservoir, with a funnel shaped tube E extending from the reservoir to near the bottom of the chamber, with its small end F open, to discharge the liquor into the measuring chamber.

The liquor enters the tube E at its largest and upper end, the top of the chamber D outside the tube E being tight. To enable the liquor to rise in the chamber, D, above the mouth F, the top of the chamber is provided with a vertical adjustable tube, L; which may extend above the top of the reservoir through a hole, and down to near the bottom of the chamber, and may be indexed or marked to denote any particular quantity in the measure up to its lower end; above which the liquor will not rise, because the air has no escape above the lower end of this adjustable tube L. A small neck, N, is formed in the reservoir over the chamber, in which is secured a cork, M, through which the tube L, passes, and by which it is held air tight, to any index point or measure desired to be drawn off.

The liquor may be admitted into this measure by a spigot, and drawn off by another spigot where large quantities are to be measured off. Where small quantities for use at bars or table, &c., are frequently to be drawn, I further construct the apparatus as shown. To the bottom of the chamber D, is attached a conical discharge tube I, the small end being up and receiving the liquor.

Through the tube E and I is inserted a screw cut rod, H, carrying a cork, G, secured and regulated by nuts, and also a cork, J, secured in like manner, so that they shall open and close in the cone seats of respective tubes E and I alternately.

Below the tube, I, and cork, J, fast to the rod, H, is secured the receiving spout, K, which will discharge the liquor into the glass, O, or into another spout to lead it wherever desired. It is necessary to open and close these tubes E and I very quick at one operation by means of the corks G and J, so as to prevent a continuous stream of liquor from running through from the reservoir, A. To do this, a slot, P, is made in the rod, H, which operates the corks; the slot extending from *r* to *s* or of any suitable length for that purpose; and the lower end of the rod H running through and guided by the base plate Z' and the bottom Z'' of wood, so as to steady the rod. This slot, or rod and corks, is operated by the bent lever U, T, on its center V, by means of the cam point W, roller X and spring Y, on being drawn by the rod U' or pushed by the same operating on the lever U, T; which lever is quickly forced up or down by the spring Y and roller X acting on the sides of the cam point, W, alternately. The lever arm, T, thus operating in the slot, P, quickly under the influence of the power of the spring, Y, instantly opens the tube I by means of the cork J, and closes the tube E by means of the cork, G, so as to shut off the measure of liquor from that in the reservoir, and allow the quantity measured to run out at the tube I into the spout, K, to be received in a glass, &c. By pulling the rod U' it again causes the tube I to close, and the tube E to open and another measure to enter the chamber.

The reservoir and various parts of the apparatus may be supported in any convenient way, or arranged in a box, and worked by a series of levers operating finally on the arm U, or in any other convenient way depending upon the location of the apparatus in the place in which it is to be used.

The spring Y is regulated to suit the cam point W, by means of a slot, Z, and bolt in the metallic base Z', which sets on the wooden base Z''.

What I claim as my invention is—

1. The measuring chamber D and its internal vertical supply tube E communicating at its bottom F with the chamber, in

combination with the vertical adjustable regulating tube L, essentially as described so that by raising or lowering the tube L, the quantity of measured liquor may be increased or diminished, as desired.

5  
2. The stoppers J and G, in their respective coned tubes I and E, on the rod H; in combination with the lever U, T essentially as described, by means of the slot P; so that  
10 the lever may quickly open and close the

stoppers at one operation, to admit, or discharge the measured liquor, without permitting a continuous stream to pass from the reservoir through the measuring chamber.

HIRAM JAMES.

Witnesses:

W. W. HUBBELL,  
S. LAMB.