

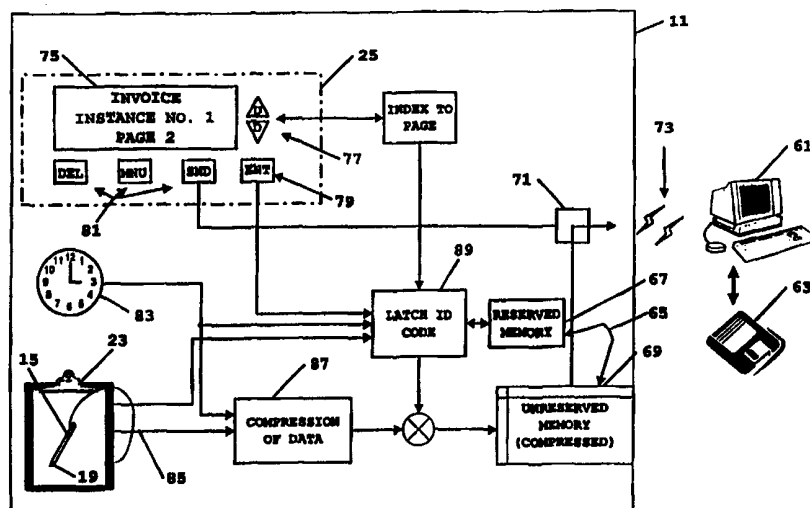

INTERNATIONAL APPLICATION PUBLISHED UNDER THE PATENT COOPERATION TREATY (PCT)

<p>(51) International Patent Classification ⁶ : G06F 3/033, 17/24</p>	<p>A1</p>	<p>(11) International Publication Number: WO 99/23545</p> <p>(43) International Publication Date: 14 May 1999 (14.05.99)</p>
<p>(21) International Application Number: PCT/US98/22874</p> <p>(22) International Filing Date: 28 October 1998 (28.10.98)</p> <p>(30) Priority Data: 08/962,489 31 October 1997 (31.10.97) US</p> <p>(71) Applicant: HEWLETT-PACKARD COMPANY [US/US]; Legal Dept., MS 20BN, 3000 Hanover Street, Palo Alto, CA 94304 (US).</p> <p>(72) Inventor: SIEGEL, Polly, S., K.; 852 Madonna Way, Los Altos, CA 94024 (US).</p> <p>(74) Agent: SCHUYLER, Marc, P.; Hewlett-Packard Company, Legal Dept., MS 20BN, 3000 Hanover Street, Palo Alto, CA 94304 (US).</p>		<p>(81) Designated States: JP, European patent (AT, BE, CH, CY, DE, DK, ES, FI, FR, GB, GR, IE, IT, LU, MC, NL, PT, SE).</p> <p>Published <i>With international search report.</i> <i>Before the expiration of the time limit for amending the claims and to be republished in the event of the receipt of amendments.</i></p>

(54) Title: SYSTEM FOR EDITING GRAPHICAL DATA BASED UPON RELATIVE TIME OF ENTRY



(57) Abstract

This disclosure provides a system for editing graphical data based upon relative time of entry, and in particular, provides editing software used with an electronic digitizing clipboard. A stylus of the clipboard is used to write on pages, with a digitizer underneath the pages generating an electronic record of entered marks for storage and later recreation of the pages. The electronic record represents both stylus spatial coordinates, normally sampled every ten milliseconds, and certain user commands such as page identification, inserted at significant locations within the aggregate data stream. Data in the stream is associated with prior page identification commands, such that subsequent data may be cut or sorted based upon timing of that data relative to the page identification commands. In this manner, the remote editor, and splicing software on the editor, may distinguish data based upon time of entry, and move that data notwithstanding any spatial overlap with other stylus data.

FOR THE PURPOSES OF INFORMATION ONLY

Codes used to identify States party to the PCT on the front pages of pamphlets publishing international applications under the PCT.

AL	Albania	ES	Spain	LS	Lesotho	SI	Slovenia
AM	Armenia	FI	Finland	LT	Lithuania	SK	Slovakia
AT	Austria	FR	France	LU	Luxembourg	SN	Senegal
AU	Australia	GA	Gabon	LV	Latvia	SZ	Swaziland
AZ	Azerbaijan	GB	United Kingdom	MC	Monaco	TD	Chad
BA	Bosnia and Herzegovina	GE	Georgia	MD	Republic of Moldova	TG	Togo
BB	Barbados	GH	Ghana	MG	Madagascar	TJ	Tajikistan
BE	Belgium	GN	Guinea	MK	The former Yugoslav Republic of Macedonia	TM	Turkmenistan
BF	Burkina Faso	GR	Greece	ML	Mali	TR	Turkey
BG	Bulgaria	HU	Hungary	MN	Mongolia	TT	Trinidad and Tobago
BJ	Benin	IE	Ireland	MR	Mauritania	UA	Ukraine
BR	Brazil	IL	Israel	MW	Malawi	UG	Uganda
BY	Belarus	IS	Iceland	MX	Mexico	US	United States of America
CA	Canada	IT	Italy	NE	Niger	UZ	Uzbekistan
CF	Central African Republic	JP	Japan	NL	Netherlands	VN	Viet Nam
CG	Congo	KE	Kenya	NO	Norway	YU	Yugoslavia
CH	Switzerland	KG	Kyrgyzstan	NZ	New Zealand	ZW	Zimbabwe
CI	Côte d'Ivoire	KP	Democratic People's Republic of Korea	PL	Poland		
CM	Cameroon	KR	Republic of Korea	PT	Portugal		
CN	China	KZ	Kazakstan	RO	Romania		
CU	Cuba	LC	Saint Lucia	RU	Russian Federation		
CZ	Czech Republic	LI	Liechtenstein	SD	Sudan		
DE	Germany	LK	Sri Lanka	SE	Sweden		
DK	Denmark	LR	Liberia	SG	Singapore		
EE	Estonia						

**SYSTEM FOR EDITING GRAPHICAL DATA BASED
UPON RELATIVE TIME OF ENTRY**

5 The present invention relates to a system for editing graphical data based upon relative time of entry. In particular, it provides a device that processes a sequence of data in a manner such that data can be filtered and assigned to different pages of graphical data based upon relative time of entry,
10 notwithstanding spatial overlap of the data.

BACKGROUND

15 Electronic data capture devices have recently gained popularity as an effective way to electronically capture and index data. For example, delivery services, retail stores, manufacturers and others commonly use such electronic devices to partially or completely replace data entry on conventional paper forms, so that
20 data may be stored electronically, saving space associated with records retention. To cite another example, many retail stores now use signature capture devices to process credit card transactions; a customer signs his or her name upon a paperless electronic
25 capture device, in lieu of using a carbon form. A hardcopy receipt bearing a reproduced signature and purchase record is then printed for the customer, while the retail store retains only an electronic record of the transaction.

30

Most such electronic capture devices are designed to be relatively foolproof, e.g, such that entered data is automatically applied to the correct document, and little possibility exists for transposing
35 signatures or data to the wrong transaction. In the case of capture devices controlled as one element of a multiple step process (e.g., credit card processing),

error is typically controlled by processing only one transaction at a time and accepting a customer signature only at a specific time in the process so that the signature is unambiguously associated with the proper transactional data. Similarly, in the case of portable devices used in inventory tracking and similar applications, capture devices are frequently designed to be used with only one form at a time.

10 While generally useful for their intended purposes, these electronic devices (and many others intended to electronically replace conventional forms-processing practices) often suffer from being somewhat rigid, for example, in not permitting editing of entered data. Further, devices required to internally store electronic data (e.g., portable devices) must frequently contain substantial internal memory, making such devices costly and heavy. In many conventional paper processing applications, it is generally desired to allow a user to move around and concurrently handle multiple forms, as one might do while completing standard hardcopy forms.

 Recently, U.S. Patent No. 5,629,499 (the "'499 Patent") has provided a partial solution to the problem of concurrent processing of multiple paper pages or forms, via that patent's disclosure of a multiple page, portable, digitizing clipboard. Using the clipboard, a user can actually write upon multiple, stacked pieces of paper, with a digitizer beneath the paper capturing pen stroke information; a user interface is utilized to switch a displayed indication of the current page between the multiple pages, and captured electronic data is thereby associated with the selected page. Thus, a user can simultaneously enter data on several hardcopy pages, all stacked upon the clipboard, while the clipboard simultaneously and automatically also creates

electronic information corresponding to pen strokes for archiving or recreating each hardcopy page.

Unfortunately, the principal embodiment shown by
5 the '499 Patent requires a user to correctly and timely switch definition of the current page so that the electronic information is associated with the proper page. Failure to properly switch page definition could potentially result in information being associated with
10 the wrong page; if the user did not properly switch page definition, then data intended for different pages might be incorrectly associated with a single page, in a spatially overlapping manner. The '499 Patent also does not teach any way of editing entered data.

15

A definite need exists for a system for a mechanism for significantly reducing the impact of errors caused by data transposed between multiple forms. A definite need also exists for a system that provides
20 for ready editing of entered electronic data. Ideally, such a system should be usable not only with handwriting capture devices, such as those referred to above, but should be applicable to a broad range of devices and applications that create data representing graphics or
25 spatial coordinates. The present invention solves these needs and provides further related advantages.

SUMMARY OF THE INVENTION

30

The present invention solves the aforementioned needs by providing a system that processes a sequence of data in a manner such that data can be filtered and assigned to one of multiple pages based upon relative
35 time of entry, notwithstanding any spatial overlap of data. In particular, the present invention provides machine readable instructions that permit filtering of

data in much the same manner as one might edit video
tape, e.g., by displaying entry of data with respect to
time and providing an operator with play forward and cut
capabilities. As a result, the present invention
5 provides an easy to use system that can be inexpensively
implemented in nearly any graphics processing
environment, e.g., on personal computers.

A first form of the invention provides
10 instructions for controlling a machine, stored on
machine readable media. These instructions (e.g.,
software, firmware, or another method of controlling a
machine) permit an operator to edit data based upon
relative times associated with that data. The
15 instructions associate the data with a first graphics
display window, and accept inputs from the operator
defining relative time parameters to define a subset of
data. The instructions then separate the subset of data
from the data, to leave remaining data, which can be
20 displayed in the first graphics display window. In this
manner, the subset of data (e.g., individual stylus
strokes, or groups of or portions of them) may be
removed from the remaining data based upon their
associated relative times, notwithstanding any spatial
25 overlap in spatial coordinates of the data.

In more particular aspects of this form of the
invention, the data can be stylus stroke data,
representing continuous stylus strokes and sampled at
30 regular and periodic intervals (e.g., each ten
milliseconds when the stylus is being used). The
instructions may operate in a manner that causes the
machine to display data according to time of entry, such
that the operator can play data forward and backward,
35 and simulate entry of data upon a display monitor at
approximately the rate at which data was originally
entered.

A second form of the invention provides a method which performs similar tasks to the instructions just described.

5 The invention may be better understood by referring to the following detailed description, which should be read in conjunction with the accompanying drawings. The detailed description of particular preferred embodiments, set out below to enable one to
10 build and use particular implementations of the invention, is not intended to limit the enumerated claims, but to serve as particular examples thereof.

15 **BRIEF DESCRIPTION OF THE DRAWINGS**

FIG. 1 shows a digital electronic clipboard including both a digitizer section and a stylus, which has an inking tip at one end; the clipboard is seen as
20 mounting two stacked pages (one of which, the top page, has a corner upturned).

FIG. 2 is a diagram showing a logical hierarchy of forms organization of the clipboard of FIG. 1.

25 FIG. 3 is an illustrative diagram indicating data processing elements of the clipboard of FIG. 1, and how those elements cooperate to create a data stream for selective transmission to a remote editor (e.g., a
30 remote personal computer).

FIGS. 4-8 illustrate the preferred data compression scheme used by the clipboard of FIG. 1, with FIGS. 4-8 each representing one data packet consisting
35 of either one command code or a set of spatial coordinates of the stylus' tip; as seen in FIGS. 4-8,

the data compression scheme used by the clipboard results in each data packet occupying two to six bytes.

FIG. 4 is a diagram used to illustrate the format of one packet of uncompressed data {x,y,p}, with two bytes of "x" data, two bytes of "y" data, and two bytes of "type" data represented by the packet; the three first bits of the first byte indicate that full value "x" data, "y" data and "type" data are present in the packet.

FIG. 5 shows a data packet similar to that of FIG. 4, but without any "type" data, as indicated by a logical "zero" in the high-order bit of the first byte. When the data packet represents stylus data, as opposed to a code, non-inclusion of the "type" data field indicates that there has been no change in data type.

FIG. 6 shows a data packet similar to that seen in FIG. 5, but in which "x" data is compressed to one byte, such that the packet includes one byte of "x" data, and two bytes of "y" data. Compression of "x" data to one byte is indicated by a logical "one" in the second highest order bit of the first byte. The compressed "x" data represents a six bit signed offset from the "x" value of the previous data point.

FIG. 7 shows a data packet similar to that seen in FIGS. 4-6, but in which "y" data is compressed to one byte, such that the packet includes two bytes of "x" data, followed by one byte of "y" data. Compression of "y" data to one byte is indicated by a logical "one" in the third highest order bit of the first byte. The compressed "y" data represents a seven bit signed offset from the "y" value of the previous data point.

FIG. 8 shows a data packet similar to that seen in FIGS. 4-7, but in which each of the "x" data and the "y" data are compressed to one byte (indicated by logical "ones" in the second and third bits of the first byte, respectively), and in which no "type" data is present (indicated by a logical "zero" in the first bit of the first byte).

FIGS. 9-18 are used to indicate processing of data by a remote computer to separate spatially overlapping data (in electronic form) into two separate image pages based upon relative time of data entry. FIGS. 9-10 each show writings entered using the clipboard of FIG. 1 where it is presumed that a user forgot to electronically indicate a page change using the user interface of the clipboard; in FIGS. 9-10, the user has first entered a dollar amount upon a top page (FIG. 9), then switched to a bottom page (FIG. 10) to enter the text "Have a nice day," and lastly, switched back to the top page (FIG. 9) to enter two initials. FIGS. 12-18 represent a "splicing" program used by a remote computer, to separate the spatially overlapping data and form two separate pages from that data to correspond with what was originally entered on the pages on the clipboard.

FIG. 9 represents aggregate writings upon a top page mounted by the clipboard, respectively, a dollar amount and two initials.

FIG. 10 represents aggregate writings upon a bottom page mounted by the clipboard, namely, the text "Have a nice day" (entered after the writing of the dollar amount on the top page indicated by FIG. 9, but before entry of the two initials upon the top page indicated by FIG. 9).

FIG. 11 represents an image formed from electronic data representing both pages of FIGS. 9 and 10, where there has been no intervening command to identify the transitions from the top page to the bottom page, and back again; the captured electronic data consequently indicates spatially-overlapping data all on a single page.

FIG. 12 shows a screen of a "splicing" program run upon a remote personal computer; a status bar at the top of the FIG. 12 indicates that time is "early" in the writing process represented by FIGS. 9 and 10, e.g., corresponding to a time prior to entry of any writings on either the top or bottom pages. FIG. 12 also indicates the presence of "fast rewind," "play backward," "play forward," "fast forward," "pause," "mark" and "cut" buttons, which are displayed at the bottom of the screen.

FIG. 13 is a representation similar to FIG. 12, but in which the "play" button has been pressed and some time has passed, as indicated by the status bar at the top of FIG. 13; the sequence of data entered using the clipboard has been "played forward" to correspond to the time just after entry of the written amount (\$69.95), upon a graphical representation of the top form (from FIG. 9).

FIG. 14 is a representation similar to FIG. 13, but in which more time has passed, corresponding to the writing of both of the amount (\$69.95) upon the top form (FIG. 9) and the text "Have a nice day" upon the bottom form (FIG. 10), without the user having input a page identification command through the clipboard's user interface. The operator has at this point in time selected the "pause" button, just after entry of the text "Have a nice day;" in addition, the operator has

also selected the "mark" button, to mark a reference point in time.

5 FIG. 15 is a representation similar to FIG. 14, but in which the "play backward" button of the computer screen is illustrated as selected, to scroll writings with respect to time backward prior to commencement of writing "Have a nice day."

10 FIG. 16 is a representation similar to FIG. 15, but in which the "play backward" button has been deselected and the "pause" button has been highlighted, so freeze writings at a point just after entry of the amount (\$69.95).

15 FIG. 17 is a representation similar to FIG. 16 in which the operator has now selected the "cut" button, thereby removing all writings in reverse time sequence from the "mark" point to the current point, and entering
20 them into a "cut" window.

FIG. 18 is a representation similar to FIG. 17, but in which the operator has now placed cut writings into a new graphics window, identified as "page 2", and
25 has also selected the "play forward" button of the first graphics display window, such that the subsequent initials ("tj," entered later in time) will be placed into the first window together with the monetary amount (\$69.95), to correspond to the hardcopy, top form (FIG.
30 9).

DETAILED DESCRIPTION

35 The invention summarized above and defined by the enumerated claims may be better understood by

referring to the following detailed description, which should be read in conjunction with the accompanying drawings. This detailed description of a particular preferred embodiment, set out below to enable one to
5 build and use one particular implementation of the invention, is not intended to limit the enumerated claims, but to serve as a particular example thereof. The particular example set out below is the preferred specific implementation of a data entry system, namely,
10 a digital electronic clipboard and a remote editor and splicing software. The invention, however, may also be applied to other types of systems as well.

I. INTRODUCTION TO THE PRINCIPAL PARTS.

15

The present invention is embodied in a digital electronic clipboard 11 having special applications to page and form processing systems. U.S. Patent No. 5,629,499 (the "'499 patent") sets forth background
20 relating to a clipboard design utilized in the preferred embodiment, and is hereby incorporated in reference in its entirety, as though reproduced herein.

With reference to FIG. 1, a digital electronic
25 clipboard 11 is illustrated as including a digitizer section 13, which supports a top page 14 (e.g., blank paper or a preprinted document having data entry fields), a stylus 15 for writing on pages and generating electronic stylus data, and a tether 17, which
30 physically and electronically connects the stylus to the clipboard. In the context of the present invention, it is desired to provide a user with the ability to concurrently process multiple forms, and to this effect, a corner 18 of the top page is seen as "lifted" to
35 reveal the presence of a second, bottom page 20, beneath the top page. The clipboard may be utilized for writing upon each page 14 or 20, and switching between them as

desired, to both complete entry of data on paper forms and simultaneously generate electronic records of all information written upon each page.

5 The clipboard 11 further includes a clip mechanism 21, for pinning the pages 14 and 20 to a paper supporting surface 23, and for permitting ready addition of a large number of additional pages, all in stacked relationship; FIG. 1 also indicates use of a built-in
10 microphone 24 which may be optionally used to input audio data linked to specific forms or specific fields appearing on preprinted forms. The stylus has a writing tip 19 (such that the user marks the pages, e.g., by ink, pencil or otherwise), a pressure sensing mechanism,
15 and position sensing electronics which generate signals representing location of the writing tip 19 with respect to the digitizer section 13. The stylus 15 may further include a light emitting diode ("LED") 35, which is illuminated when the writing tip 19 is pressed against a
20 page (e.g., when the stylus is being used to write upon the page).

While the user may enter data on hardcopy pages in any order desired, the clipboard 11 is preferably
25 "informed" when the user ceases writing on one page 14 or 20 and begins writing upon the other page 20 or 14. To this effect, a number of mechanisms may be implemented to electronically mark a page change in the electronic records. For example, the preferred
30 clipboard 11 includes a user interface 25, which has an electronic display and buttons for displaying and selecting specific user commands from a predefined menu, such as for notifying the clipboard which page the user is writing on. The system may also include a bar code
35 scanner (not shown in FIG. 1) for scanning a bar code 27 mounted upon each page each time the user newly writes on the page having the bar code. The bar code, in this

implementation, would contain information about form
"type," e.g., "invoice," as well as a unique serial code
(form "instance") which distinguishes a completed
hardcopy "invoice" from other "invoices." It should be
5 recognized that the clipboard 11 need not be used only
with pages having preprinted information (e.g.,
"invoice") and that blank pages may be used as well and
identified by a bar code or identifier in precisely the
same manner. Details of a bar code scanner suitable for
10 use with the clipboard 11 may be obtained in reference
to copending application no. ___/___,___, for a "Handheld
Writing Device and Related Data Entry System," filed on
the same date as this disclosure, by inventors Robert
Leichner, Bo Curry and Dan Flickinger, which is hereby
15 incorporated by reference in its entirety, as though set
forth herein.

In the context of the present invention, page
change commands and data from the stylus and digitizer
20 are integrated into a single, sequenced data stream,
which represents both user commands and stylus data.
The stylus 15 is sampled by clipboard electronics each
ten milliseconds, to produce a continuous stream of
stylus position data, representing "x" and "y" spatial
25 coordinates with respect to the clipboard, as well as
pressure upon a writing tip of the stylus. This
pressure indication in the preferred embodiment includes
a one-bit tip-down signal, indicating whether the
writing tip is depressed against a page (e.g., the
30 stylus is being used to "write"), but could also be made
to occupy more bits to represent relative pressure, or
"darkness" of each pen stroke upon the page.

While a user of the clipboard 11 may be
35 presented with several options for selecting page change
commands (e.g., via the bar code scanning option,
discussed above), the user interface 25 preferably may

always be used to select commands. This selection is performed by using scroll buttons, to scroll through descriptions for different forms or pages, which are individually displayed for the user. An "enter" button
5 is then utilized, while a selected description is displayed, to trigger insertion of an identifier for the desired page or form into the data stream, as has just been described.

10 In connection with the "type" data, user commands from the user interface as well as certain other commands are inserted sequentially into the stream of stylus data as escape characters; that is to say, the commands are inserted as soon as possible into the data
15 stream, e.g., immediately, if no stylus data is being concurrently processed, or immediately after a sample of stylus data which is concurrently being processed. A resulting aggregate data stream, including certain commands which have been merged with stylus data, is
20 sequentially stored in memory internal to the clipboard 11, for later upload to a remote editor (preferably, a remote computer running suitable data editing and clipboard interface software). If the inserted command is an identification of a particular form (e.g., the
25 bottom form 20), the position of that command within the aggregate data stream is temporally significant and all electronic data following that identification in the memory can be associated with the bottom form, until
30 another electronic identifier indicates a change to another page.

The electronic identifier (for the page change) which is inserted in the data stream should preferably specifically identify the type of form utilized, such
35 that any preprinted information can be electronically merged with entered stylus data once the information has been transferred to the remote computer. For example,

if a user of the clipboard 11 is completing an "invoice", the electronic data generated by the clipboard preferably includes a code that enables a program running on the remote computer (not seen in FIG. 1) to electronically associate an image of a blank invoice with the electronic data; that is to say, the clipboard generates data which can later be combined with an electronic image of a form. In addition, use of a code representing both form "type" and "instance" permits the remote computer to automatically merge entered data with previously entered data for the same page or form; a user can start filling out a form during one clipboard session, upload data to the remote computer, and then complete the same page or form during a second session, and the software of the remote computer can associate the data with the same page or form. Specific codes for each page or form are not the only mechanism for tracking forms, and the clipboard can also use an index which merely identifies active pages upon the clipboard, e.g., pages 1-132. In the preferred embodiment, both the index and specific codes are used by the clipboard and remote computer to track and process pages and forms. As used herein, the term "form" includes both preprinted and blank forms which may have one or more "pages."

The preferred clipboard embodiment generates and organizes entered data in such a manner that it can easily be edited after generation, even if a user forgets to mark, or improperly marks, a page change. In this context, it is desired in many applications to have a flexible system usable in creating and marking many different pages. The preferred clipboard meets this need by generating a single data stream, representing all data entered using the stylus 15, and certain commands entered by the user, sequentially arranged within the stream for easy later sorting or editing of

stylus data. Via software on the remote computer, stylus data can then be displayed in an image window dedicated to each form. The software permits storage of the displayed data only, or merging of the displayed data with image information representing the "type" of form (e.g., an image of a blank "invoice") for recreation of the form. Importantly, as further described below, the remote computer preferably also runs "splicing" software which permits processing of stylus data based upon relative time of entry, such that stylus data can be distinguished, cut and reassigned between multiple pages, notwithstanding any spatial overlap with other (correctly assigned) stylus data.

Prior to further explanation of the functional configuration of the preferred clipboard, it will be helpful to explain the nature of some commands used in the preferred embodiment, as well as preferred forms hierarchy for varied applications of the clipboard. Use of a forms hierarchy, such as that described below, permits ready adaptation of the clipboard to certain commercial uses where defined, preprinted forms are commonly used.

A. COMMANDS.

Commands can be generated automatically by the clipboard, by the user (through the user interface) or by the remote computer. One example of a command automatically generated and inserted directly into the data stream by the clipboard is a time stamp, which can be inserted into the data stream with each new stylus "stroke" (e.g., each time "pressure" on the writing tip indicates new contact between the stylus and a page); a time stamp could also be generated by a clipboard central processing unit ("CPU") with each sampling of stylus data, and formed as part of the original stream

of stylus data sampled and formatted by the CPU. Examples of a command generated by the user would include most anything input using an "enter" button of the user interface, such as selection of a new page for
5 writing, creation of a new form "instance," deletion of a page from the clipboard's active memory, or upload of data from the clipboard's serial memory to the remote computer. A command from the user might also take the form of a scanned bar code of the form, or of a package,
10 if a bar code scanner is connected to the clipboard. Finally, commands from the remote computer might include a request for retransmission of data, download of additional forms definitions to the clipboard, or a download of software to be run on the clipboard's CPU.
15 Communication between the remote computer and the clipboard can occur via any mechanism, such as infrared communications but, preferably, the clipboard primarily relies upon a serial communications port (such as a RS-232 or similar standard computer interface) for
20 communication with the remote computer.

In the context of the present invention, commands identifying that the user desires to write on or create a specific form instance (and page, if
25 appropriate) are directly inserted into the stylus' data stream, at a significant location. Preferably, a number of pre-existing forms are known to the clipboard, and new forms can be created, all as defined by a forms hierarchy (such as described below in reference to FIG.
30 2). Switching between known forms can be effected using the CPU's active forms list, by using the user interface 25 to select one of multiple pages on the clipboard and by selecting that page by pressing an "enter" key when the appropriate selection is displayed. If a bar code
35 scanner is used to scan a bar code representing a page, the CPU is instructed by firmware to first search the active forms list, to determine whether a scanned bar

code corresponds to an active form and, if not, the CPU then automatically creates a new form (adding pages and form type definition to the active forms list). If the user is manually utilizing the user interface 25 to signify addition of a new page to the clipboard, the user selects a "create form" menu option, and form type, instance and page menu options, as exemplified below in connection with a discussion of FIG. 2. Commands from the user interface 25 selecting or creating pages are executed (and inserted into the stylus' data stream) at the time that the user presses the "enter" key.

Specific commands selected by the user are not the only type of commands which are inserted into the data stream; as an example, each time the stylus is newly depressed against a page, a time code is automatically inserted into the data stream, indicating both date and time of day.

20 **B. DEFINITIONS OF FORM TYPE AND INSTANCE.**

FIG. 2 illustrates a hierarchy 37 of hypothetical forms stored in the clipboard's memory, a hierarchy which can be tailored to a specific application. For example, FIG. 2 illustrates commonly used business forms, including, "purchase order" 39, "invoice" 41, "release" 43 and "new form" 45 (i.e., blank or unknown pages). The listed hierarchy would be used to either define a new form or activate an old form and cause the CPU to add the form to its list of active forms.

In using the user interface 25 to access the stored hierarchy of predefined form types, a user would scroll through root menu commands such that the word "forms" 47 is displayed by a Liquid Crystal Display ("LCD") of the user interface, and would push an "enter"

button. The user would then scroll through predefined forms "purchase order" 39, "invoice" 41, "release" 43 and "new form" 45, and would push the "enter" button again to select whichever selection is displayed upon the LCD. Having thus selected general form "type," the user preferably then begins another menu selection process, where the user can select either an existing "instance" 49 (e.g., a previously commenced form already having data) or a new instance 51 (uncommenced, blank form). Upon selecting a new instance, a new instance number is assigned to the new form (e.g., existing release number two), etcetera. If the form is a type which includes multiple pages, the user is presented with another menu that permits the user to select a particular one of the multiple pages, and so on, as indicated by the reference numeral 53 in FIG. 2. As further indicated by reference numeral 55 of FIG. 2, a user can define a new form (e.g., a blank page or previously undefined form type) consisting of either a single page or multiple pages, as designated by reference numerals 57 and 59, respectively.

Data entered onto forms are not electronically displayed to the user, nor is stylus data from a previously commenced form instance necessarily stored in the clipboard's internal memory. Rather, each time a page is newly created or activated, an index is created in a memory space reserved by the clipboard's CPU for use in processing various commands. Completed form instances preferably are deleted from memory once a form or page is completed and uploaded to the remote computer (e.g., either via a command automatically sent from the remote computer, or via selective use of the user interface).

35

For example, when a user initially begins a new form instance, data entered for the new form instance

will be stored in the clipboard's internal memory (together with command codes). A page identification code will also be generated and stored in the CPU's reserved memory space and in the data stream.

5 Subsequently, the user can optionally upload the contents of the sequential memory corresponding to the page or form to a remote computer, and erase the corresponding data, such that the clipboard no longer has memory of entered data; the clipboard does, however,
10 selectively retain memory of the form identification code of the specific form instance which has been created. As a consequence, the user can subsequently recall the form instance to add additional data, which is then stored in the clipboard's memory. The clipboard
15 does not display entered data, but simply identifies it to the remote computer as corresponding to the specific form instance. When the contents of the sequential memory are again uploaded to the remote computer, the page identification codes inserted into the sequential
20 memory are used by the remote computer to combine the original uploaded data with the new uploaded data. Importantly, each stylus stroke will have at least one associated time of entry, and so, different stylus strokes are distinguished by time of entry and can be
25 separated by the remote computer and be reassigned to different forms, notwithstanding any spatial overlap.

30 **II. PREFERRED HARDWARE FUNCTIONAL CONFIGURATION.**

Physical and electronic configuration of the preferred device will now be additionally explained with reference to FIG. 3.

35 The clipboard and its internal, functional components are indicated by the reference numeral 11 of FIG. 3. FIG. 3 also indicates use of remote

transmission, e.g., modem, infrared communication or other serial communications, to a remote computer 61. The remote computer, preferably a personal computer running suitable imaging and interface software is used to upload, display, process and edit entered stylus data. The remote computer can also be used to prepare the data for archiving, as indicated by the presence of a computer disk 63.

FIG. 3 shows the stylus 15 and paper supporting surface 23 (which includes the digitizer), the user interface 25, several boxes indicating CPU and support chip processing functions, and memory used by the clipboard, generally designated by the reference numeral 65 and shown in two boxes 67 and 69. Memory used for data storage is preferably non-volatile "flash" memory and, preferably, the clipboard includes both internal, permanent memory (ideally at least one megabyte) with an external slot for receiving a PCMCIA card having additional memory. The first memory box 67 represents memory space reserved in random access memory ("RAM") for CPU functions, while second memory box 69 is flash memory used for sequential storage of data and selected commands ("data memory"). FIG. 3 also indicates a data transmission port 71, which preferably includes a serial communications port for communications with the remote computer (indicated by reference numeral 73).

The preferred user interface is indicated in FIG. 3 by the reference numeral 25. A LCD 75 is used to display individual menu choices, while a set of scroll "up" and scroll "down" buttons 77 are utilized to scroll through displayable menu choices. The interface also includes an "enter" button 79 for selecting displayed menu choices, as well as a "menu" button for returning to the root menu, a "send" button for transmitting data to the remote computer, and a "delete" button for

removing form instances from the memory space reserved for the CPU (the three latter buttons are collectively designated by the reference numeral 81 in FIG.3).
Importantly, transmission of the single data stream of combined data and user commands to the remote computer 61 is not the only type of transmission that can occur, and the "send" button also is preferably used (via firmware for the clipboard) to place the clipboard in a state where it can receive both software commands and programming relating to definition of form types.

At the time a user creates a new form instance, the CPU assigns an index to each page of a form, which it stores in its reserved memory space 67 in a list of active forms, and the CPU also assigns a unique code to each page (if one is not already known to the clipboard, e.g., via memory or scanned bar code). For example, a newly created form might receive an index of "1," as well as an identification code, including a type identifier (e.g., "invoice") and a unique serial code. The user, in switching between active forms, does not need to navigate the forms hierarchy, discussed earlier, but can simply scroll through the CPU's index of active forms and use the "enter" key 79 to switch between multiple pages stacked on the clipboard's surface. Data entered using the stylus 15 will be associated with the currently selected page, and the stylus position is detected even if there are a large number of underlying pages between the paper supporting surface and the form being written upon by the user.

Each time the writing tip 19 is newly depressed, the clipboard's CPU samples a real time clock 83, and inserts this data (including date and time of day) into a data stream from the clipboard and stylus. The clipboard is normally maintained in a sleep mode, and is awakened when the user places the writing tip in contact

with an object, thus closing a switch in the stylus which triggers an interrupt signal within the CPU. This interrupt signal causes the CPU to empower clipboard electronics and begin actively "listening" to the stylus. When "listening," the clipboard preferably samples data each ten milliseconds, although only data representing writings on the clipboard (e.g., when the tip-down switch is concurrently closed) will be passed to the data memory 69 as a stream of stylus data. At the same time that the clipboard processes stylus data, it compresses that data as appropriate, as indicated by block 87 in FIG. 3.

Each time a user selects a page (or creates a new page or form) using the user interface, the CPU uses the index of active page and forms to retrieve from reserved memory space the unique identification code corresponding to a particular page, and the CPU inserts this identification code (as indicated by reference numeral 89) into the data stream via a summing junction, as has been previously described. The aggregate data stream is then sequentially stored in data memory 69, with memory location indexed by form instance, page and time of entry also being recorded in the CPU's reserved memory.

In processing other user commands, the CPU relies upon its reserved memory space 67 in manipulating data stored in the sequential memory. As an example, if the user selects a menu choice of deleting a specific form and instance, the CPU checks its reserved memory space to locate data in the data memory 69 corresponding to that data. The CPU is not required to physically overwrite data in the data memory, but rather, it changes its reserved memory space to remove references indicating use of the data memory corresponding to the form. Similarly, the CPU processes requests to upload

specific form data to the remote computer 61, e.g., by instructing the sequential memory to only transmit data found at selected memory locations in the clipboard.

5

III. PREFERRED DATA FORMAT.

A. STYLUS DATA GENERATION.

10 At times when the clipboard is awake, the CPU receives stylus data as an analog signal, and it processes that data to determine stylus position and whether stylus data represents "ink" or other page markings. Beneath the paper supporting surface of the
15 clipboard, a crossing pattern of "x" and "y" driver signals, with signals separated in time and trace lines arranged in a unique configuration permit the CPU to very closely determine stylus position relative to the paper supporting surface, even when the stylus is
20 several millimeters away from that surface. For example, the paper supporting surface can repeatedly use eight different "x" driver lines and eight different "y" driver lines in a non-repeating pattern. The writing tip
25 tip 19 electronically detects these driver signals at different times and in varying relative magnitude depending upon distance between the stylus and corresponding driver signal. The stylus provides a data signal to an analog-to-digital converter, which the CPU interrogates at ten millisecond intervals; during each
30 such interval, the CPU determines relative magnitude of each of the sixteen driver signals, and uses a look-up table to uniquely determine stylus position.

 While the CPU when awake constantly "listens" to
35 stylus data (e.g., for reentering a sleep mode following a period of inactivity), the CPU preferably otherwise ignores stylus data unless the tip-down switch within

the stylus is depressed, indicating that the user is writing upon a surface. At this point, the CPU performs compression as further described below, and then loads the data into the next memory position in sequential memory as a two-to-six byte stylus position packet. The configuration of data within the stylus position packet will be further described below.

Additional details about the configuration of the preferred digitizer, and scheme for detecting stylus position, can be found in U.S. Patent No. 4,806,918, which is hereby incorporated by reference in its entirety as though identically set forth herein.

B. DATA COMPRESSION AND STORAGE IN MEMORY.

As mentioned earlier, it is desired that the preferred clipboard be lightweight while having memory sufficient to store data corresponding to entry of a large number of forms. The clipboard's CPU thus, when processing commands and data to form a single data stream, also compresses the data for sequential storage in the memory. The memory, generally indicated by reference numeral 65 in FIG. 3, preferably includes both at least one megabyte of nonvolatile memory internal to the clipboard, and it may also include expandable memory such as a sixteen megabyte PCMCIA flash card. The clipboard's CPU reserves a space in memory 67 for indexing currently active forms and for also tracking memory contents in 32 kilobyte memory blocks. Within this reserved memory space 67, the CPU stores information representing memory allocation including indices of memory used by form type, form instance, page number, and time of data entry, for processing commands either from the clipboard (via the user interface) or the remote computer.

Apart from the reserved memory space 67, data and commands intended for later use (e.g., page change commands) are stored sequentially in the remaining available (data) memory 69 on a first-come, first-served basis. In the reserved memory 67, the clipboard CPU also stores indications of used and available memory, and displays memory status to the user, either upon request or when the memory is full.

10 If the clipboard 11 is coupled by serial interface to the remote computer 61, the remote computer can command uploading of data corresponding to either the entire data memory, or to a specific page or form; this command may also be effected using the menu
15 functions of the clipboard user interface 25. Data is preferably transmitted to the remote computer in units of "pages," which are delimited by index entries in the CPU's index list. Within a page, data is transferred directly from the clipboard memory to the remote
20 computer, via the serial output link, without interpretation occurring at the clipboard. Decompression of the data, decoding of the stylus position data, and interpretation of the interpolated context and other input data, are then subsequently
25 carried out by the software running on the remote computer. Once data has been transferred from the clipboard, the user is preferably prompted whether to erase data which has been transmitted to the remote computer, or all data which is associated with the
30 particular page or form instance. If erased, the reserved memory space 67 is used by the CPU to locate data and erase data corresponding to the particular page or form instance, even if stored in fragments within the clipboard's data memory.

35

 If data memory is implemented as flash memory, memory reuse is possible if data has been deleted in

contiguous memory blocks (typically 128 K bytes), either at the beginning or end of the clipboard's data memory space. Unless sufficient memory space is available either at the beginning or end of the clipboard's data memory space, the clipboard's user interface indicates that memory is full, and data must be uploaded prior to acceptance of additional data. Importantly, a defragmentation feature could optionally be implemented in clipboard firmware, to compact valid data to fill-in unused space each time data is erased, but this option has not been implemented in the preferred embodiment. Alternatively, the user can also add PCMCIA cards, and the CPU is effective to ascertain the capacity of new memory. The occurrence of particular patterns in the input data, for example, a signal from the user interface that a new form has been inserted, may cause the CPU to add a pointer into the memory to its index, so that this particular event may be readily retrieved. Once the data has been written to the memory, it is preferably not subsequently altered or reordered.

Within this framework, the preferred compression scheme is explained with reference to FIGS. 4-8. This compression scheme utilizes data packets having {x,y,t} coordinates and representing either a code or sequential position of the stylus on the surface of the digitizing pad. In other, alternative embodiments, for example, an embodiment which include a built-in microphone, the data packets can also represent audio data, with the "t" coordinates indicating data "type" to be audio. In the uncompressed state, each packet consists of six bytes, while in the fully compressed state, a packet can have as few as two bytes.

In the case of stylus data, the uncompressed data packets include three two-byte words for the "x" coordinate, the "y" coordinate and stylus pressure and

packet type information ("t" data). Normally, stylus pressure will be indicated via one or two bits indicating whether the writing tip of the stylus is in contact with a surface, and the two bytes otherwise
5 carry identification information as to whether the packet represents either clipboard codes, stylus "type" data, or other non-stylus data.

If the "t" data bytes indicate that the packet
10 represents date or time, the four "x" and "y" bytes are interpreted as the year, month and day or as minutes and tenths of seconds after midnight, respectively. Form identification is performed using the four "x" and "y" bytes to represent raw ASCII data, e.g., from a bar code
15 scanner or a form identifier from the CPU's reserved memory space, and by encoding page number as a separate data packet.

The {x,y,t} data format is also used to
20 communicate codes not stored as part of the sequential data stream in the clipboard's memory, generally for communication with the remote computer. The clipboard can encode form index relative to the clipboard (e.g., one of one-hundred and thirty two possible active forms,
25 using the four "x" and "y" bytes to encode time together with the last seven bits of the "t" bytes carrying form index number). The clipboard can also report its memory status to the remote computer using the "x" and "y" data words to indicate the number of utilized (32K) blocks,
30 and the number of bytes in excess of a multiple of 32K, respectively.

Many other code schemes are available for encoding particular types of non-stylus data, and
35 selection of a suitable coding scheme is left to one familiar with digital communication schemes.

Preferably, stylus data is compressed to as little as two bytes for minimizing memory use and data transmission requirements, using a delta compression scheme. In the preferred scheme, indicated with
5 reference to FIGS. 4-8, the highest-order bit of the first byte is the "delta-t" flag, the second highest-order bit of the first byte is the "delta-x" flag, and the third highest-order bit of the first byte is the "delta-y" flag. Uncompressed data thus includes two
10 bytes each of "x" and "y" position values, and two bytes of packet type (or "t") data, as seen in FIG. 4. When the "delta-t" bit is set (to binary 1), the value of the two "t" bytes differs from that of the previous point, hence these two bytes are included in the data packet.
15 If the "delta-t" bit is reset (binary 0), the two "t" bytes are omitted from the data packet, as indicated by FIG. 5. If the "delta-x" bit is set, the "x" position is within +/- 31 units of the preceding "x" position and is encoded as a signed six-bit delta from the previous
20 "x" position. In this instance, the second "x" byte is omitted, as indicated by FIG. 6, and the second data byte is then the first byte of "y" information. The "x" sign bit is the most significant bit of this first "y" byte, and the magnitude of horizontal position change is
25 represented in the last five bits of the first data byte. If the "delta-x" bit is reset (binary zero), then the "x" position is outside the delta range and absolute horizontal position is encoded as an unsigned 14-bit value using the first bit of the third byte and the low
30 13 bits of the first two bytes.

If the "delta-y" bit is set, then the "y" position is within +/- 63 units of the preceding "y" position and is encoded as a signed seven-bit delta from
35 the previous "y" position. In this case, the second "y" byte is omitted, and the "delta-y" value is encoded in the low seven bits of the second data byte, as indicated

in FIG. 8. If the "delta-y" bit is reset (binary zero), then the "y" position is outside the delta range and is encoded as an unsigned fifteen-bit value representing absolute position, in the low fifteen bits of the second
5 group of "y" data bytes (e.g., either the second and third bytes, if "x" data is compressed, per FIG. 6, or the third and fourth bytes otherwise, per FIGS. 4-5).

With this scheme, the large majority of stylus
10 data points require only two bytes for representation in memory. The actual number of bytes used to represent a compressed data point can be determined from the three "delta" flags in the first byte. The scheme can very effectively be used to report "x" position across the
15 paper supporting surface with a resolution of one in 16,384 units, and "y" position with a resolution of one in 32,768 units.

C. TRANSFER OF DATA.

20 Data is stored in sequential data blocks, with the CPU using its reserve memory space to store flags identifying forms and page changes and the like; in such a manner, either the clipboard or the remote computer
25 (when in communication with the clipboard) may instruct upload of (a) memory contents, including page and form codes, or (b) data for specific pages or forms, either using the CPU's index or a unique code for the page or form (e.g., a bar code).

30 To upload data using the user interface, the user of the clipboard places the clipboard in communication with the remote computer which, as mentioned earlier, can be a personal computer running
35 suitable software. Preferably, the clipboard includes several alternative mechanisms for communication, including a serial connection (e.g., an RS-232

coupling). When turned "on," the clipboard can act in either a master or slave mode for communicating with the remote computer, either permitting the user of the clipboard to select either a page index (e.g., page 1-
5 132) or a page identification code, including form instance; the user selects appropriate menu options displayed via the LCD of the user interface, and then pushes the "send" button to trigger upload to the remote computer. Preferably, an acknowledgment from the remote
10 computer is required before upload can begin and, following upload, data which has been successfully uploaded to the remote computer is automatically erased from the clipboard. The user interface and associated menu preferably also include means for dialing a phone
15 number and controlling a modem to establish and maintain communication with the remote computer.

The remote computer, once in receipt of an uploaded file, saves the file as a distinct record on
20 hard disk. This record can then be used to (a) print entered stylus data, e.g., using a printer to print directly upon a blank page or blank preprinted form, (b) edit the entered data, for example, using the "splicing" utility mentioned below, (c) combine the entered data
25 with image data, such that the form can be recreated entirely from electronic memory and then printed upon blank paper or saved, or (d) suitably archive the entered stylus data, with an index to the type of form which was originally used (e.g., "invoice, 1995
30 version"); whether or not a code identifying page instance specifically identifies form type, the remote computer can add such information for proper archiving.

35

IV. "SPLICING" USING THE REMOTE COMPUTER.

As indicated above, software on the remote computer segregates entered data according to identified pages, such that image "windows" are created for each page of data. In addition, the software preferably provides utilities for communications with the clipboard for purposes of checking the clipboard's memory status, battery power, index of forms (either current active forms or specific "type" and "instance" codes), for determining contents of the clipboard's memory, and for uploading either all memory or data corresponding to a specific form.

The remote computer also preferably includes "splicing" software which permits a time playback of a segment of entered data upon a computer monitor, such that a user can advance forward and backward in time and "watch" a time window of entered stylus data being visually added to displayed images. With the ability to focus on a segment of time during which data was entered, the "splicing" feature enables a user to separate spatially overlapping data based upon relative time of entry, and permits that data to be reassigned to different pages of data, or data from different pages of data to be combined into a single page. The "splicing" feature is further described with reference to FIGS. 9-17.

FIGS. 9-10 each show hypothetical writings entered using the clipboard 11 of FIG. 1, where it is presumed that a page change was not electronically marked in the aggregate data stream. Illustrated via FIGS. 9-10, the user has first entered a monetary amount (\$69.95) upon a top page 14 (FIG. 9), then switched to a bottom page 20 (FIG. 10) to enter the text "Have a nice day", and lastly, switched back to the top page

(FIG. 9) to enter two initials ("tj") 105. In this example, a single data stream was created having stylus data representing (in order) (a) ten millisecond samplings of the drawing of the monetary amount
5 (including time and date codes), (b) ten millisecond samplings of pen strokes corresponding to the text "Have a nice day" (including time and date codes) and (c) ten millisecond samplings of entry of two initials (including time and date codes). When processed by
10 software on the remote computer, a resulting image 107 has the appearance indicated in FIG. 11, and it is desired to sort entered data into two image pages (as the data was physically entered on different pages).

15 In this regard, if proper electronic page markings had been entered at a significant location within the sequential data, the sequential data would have included the following (as well as appropriate time and date codes): (a) a command identifying the top page;
20 (b) ten millisecond samplings of the drawing of the money amount (\$69.95); (c) a command identifying that the user now wishes to write upon the second page; (d) ten millisecond samplings of pen strokes corresponding to the text "Have a nice day," (e) a command identifying
25 that the user now wishes to write upon the top page; and (f) ten millisecond samplings of entry of two initials ("tj"). The "splicing" feature of the software is relied upon to properly sort the data, in the absence of properly entered page identification codes.

30

FIGS. 12-18 are used to explain the operation of the "splicing" feature used by a remote computer in the previous example, to separate the spatially overlapping data and form two separate pages from that
35 data. The operator of the remote computer first uploads the entered stylus data from the clipboard (reported as

corresponding to a single form) and selects an appropriate time range and the "splicing" feature.

As seen in FIG. 12, the "splicing" feature
5 causes the software to display a graphics window 109 for recreating and displaying the act of entering data upon the multiple forms, from an electronic viewpoint. A status bar 111 at the top of the FIG. 12 indicates that time is "early" in the writing process represented by
10 FIGS. 9 and 10, e.g., corresponding to a time prior to any writings on either the top or bottom pages. FIG. 12 also indicates the presence of "fast rewind," "play backward," "play forward," "fast forward," "pause," "mark" and "cut" buttons 113, 115, 117, 119, 121, 123
15 and 125, which are displayed at the bottom of the screen. An operator of the editing software utilizes a mouse or other interface to control the buttons to move time forward or backward from with respect to data entry upon the clipboard, much in the same manner as playing a
20 video tape. If time is moved backward, images already displayed upon the screen will be erased in the reverse order in which those images were entered, sampled-point by sampled-point. If time is played forward, additional images will be displayed in the order and time in which
25 they were entered upon the clipboard.

FIG. 13 is a representation similar to FIG. 12, but in which the "play button" 117 has been pressed and some time has passed, as indicated by the status bar 111
30 at the top of FIG. 13; the sequence of data entered using the clipboard has been "played forward" to correspond to the time just after entry of the written amount 101 (\$69.95, seen also in FIG. 9). It is at this point that the user of the clipboard switched to writing
35 upon the bottom page, but since no page identification appears in the data stream, the editing program as additional time passes will erroneously superimpose

additional data (e.g., the text "Have a nice day") upon
the amount. Thus, FIG. 14 represents the remote
computer's graphics display window 109 where additional
time has passed, corresponding to the writing of both of
5 the amount (\$69.95) 101 upon the top form and the text
"Have a nice day" 103 upon the bottom form.

The operator of the remote computer then selects
the "pause" button 121 to stop the addition of further
10 writings which are later in time, and also selects the
"mark" button 123, which is used to electronically mark
a point in time with respect to the writings. As seen
in FIG. 15, the operator then chooses the "play
backward" button 115 of the graphics display window 109,
15 to thereby move backward in time while marking for edit
the erroneous data, e.g., the superimposed text "Have a
nice day." Since each datum from the input device
(e.g., the stylus) is associated with a specific time,
and each sample from the input device is kept in order
20 in a sequence, overlapping visual data may be
distinguished notwithstanding any spatial overlap of
that data. Once the operator of the computer has moved
sufficiently backward in time, as seen in FIG. 16, the
operator stops the playback by selecting the "pause"
25 button 121. At this point in time, the just-removed
text "Have a nice day" has been marked based on time
parameters entered by the operator, and only the
monetary amount (\$69.95) remains displayed in the
graphics display window 109. [Notably, the graphics
30 display window depicts the top form and the amount
(\$69.95) in their proper relative position and
orientation, as designated by the reference numeral
110.]

35 The operator then selects the "cut" button 125
(FIG. 17), which preferably causes the opening of a new,
"cut" window 127 for a separate image (i.e., the cut

writings "Have a nice day"). The operator can then create a second graphics display window 129, corresponding to a separate hardcopy page, into which the cut writings are copied (FIG. 18). This new window
5 can either contain an existing image along with the copied image superimposed with the correct spatial orientation, or a new electronic display page created by the operator; also, as with the first graphics display window 109, the second window 129 displays the cut data
10 in its proper spatial (x,y) location and orientation with respect to a form, exactly as it was physically entered on the clipboard, e.g., as represented by a form designated 130 in FIG. 18.

15 Finally, the operator then again selects the original "play" button 117, to move time forward and display additional writings in the first graphics display window 109 as they were originally entered (FIG. 18). The operator at this point is left with two
20 separate images, one corresponding to entry of data upon the top page (FIG. 9) and one corresponding to entry of data upon the bottom page (FIG. 10). Notably, in the example just illustrated, writings were marked and cut in reverse time sequence, based upon parameters entered
25 by the operator; the operator could have marked and cut writings in forward time sequence as well.

Various alternative embodiments of the present invention will occur to those having skill in
30 electronics or software. For example, another input device for creating spatially variant data may be used instead of a stylus and digitizing clipboard, such as a mouse or other implement. Software alternatives will also occur to those having programming skill, which
35 effect splicing of input-data based upon time, to sort that data between different image windows or other

applications; all of these modifications are viewed as within the spirit of the present invention.

Having thus described several exemplary
5 implementations of the invention, it will be apparent that various alterations, modifications, and improvements will readily occur to those skilled in the art. Such alterations, modifications, and improvements, though not expressly described above, are nonetheless
10 intended and implied to be within the spirit and scope of the invention. Accordingly, the foregoing discussion is intended to be illustrative only; the invention is limited and defined only by the following claims and equivalents thereto.

15

CLAIMS

1. An apparatus comprising instructions stored on machine readable media, wherein the instructions cause the machine to permit an operator to edit data based upon relative times associated with that data, the instructions controlling the machine to:
- 5 associate the data with a first graphics display window;
- accept inputs from the operator defining relative time parameters;
- 10 select a subset of the data based upon inputs from the operator;
- separate the subset of data from the data, to leave remaining data; and
- display the remaining data (without the subset of data) in the first graphics display window;
- 15 wherein the subset of data in the first graphics window may be removed from the remaining data based upon associated relative times, notwithstanding any spatial overlap in spatial
- 20 coordinates between the subset of data and the remaining data when displayed.

2. An apparatus according to claim 1, wherein the data is stylus stroke data and includes data representing at least two complete stylus strokes, each stylus stroke being associated with a time of entry,
- 5 said instructions further controlling the machine to:

 select, separate and display such that at least one complete stylus stroke is selected and separated from the data, and displaying the

10 remaining data without the at least one complete
stylus stroke which has been selected and
separated.

3. An apparatus according to claim 2, wherein the
stylus stroke data includes samples taken at periodic
intervals, the samples representing continuous stylus
motion, each sample associated with a time of entry, and
5 wherein said instructions control the machine to:

accept inputs from the operator that represent
relative time parameters for contiguous stylus
data within one stroke; and

10 select, separate and display such that the
contiguous stylus data is removed from the first
graphics display window.

4. An apparatus according to claim 1, wherein the
relative times represent time of associated data entry,
said instructions further controlling the machine to:

select relative time parameters via

5 displaying data according to time of entry,
and

10 accepting inputs from the operator and
responsively causing the display of data
such that data is played forward with
respect to time of entry, such that the data
entry is simulated to the operator at
approximately the rate at which data was
originally entered.

5. An apparatus according to claim 1, said
instructions further controlling the machine to:

5 provide operator-selective placement of the
subset of data into a second graphics display
window, such that the subset of data is
displayed in the second graphics display window,
but not the remaining data.

6. An apparatus according to claim 5, wherein said
instructions further include controlling the machine to:

5 provide the operator with ability to copy a
second subset of data from the first graphics
display window to the second graphics display
window without removing the second subset of
data from the first graphics display window.

7. An apparatus according to claim 1, wherein the
instructions further control the machine to display
operator selection buttons of play, mark and cut, and to
accept operator selections of said operator selection
5 buttons.

8. An apparatus according to claim 1, wherein the
instructions further control the machine to display
operator selection buttons of play forward, play
backward and pause, and to select operator selections of
5 said operator selection buttons.

9. A method of editing data representing spatial
coordinates, wherein the data is associated with
relative times, the method using a computer processing
device, an operator interface, a display monitor, and at
5 least a first graphics display window, said method
comprising:

associating the data with the first graphics
display window;

10 selecting relative time parameters corresponding to the data via the operator interface;

separating a subset of data from the data, the subset differentiated from remaining data based upon the relative time parameters; and

15 displaying the remaining data (without the subset of data) in the first graphics display window;

20 wherein the subset of data may be removed from the remaining data (of the first graphics display window) based upon associated relative times, notwithstanding any spatial overlap in spatial coordinates between the subset of data and the remaining data when displayed together.

10. A method according to claim 9, wherein the data is stylus stroke data and includes data representing at least one complete stylus stroke, the at least one stylus stroke being associated with a time of entry,
5 said method further comprising:

10 selecting, separating and displaying such that at least one complete stylus stroke is selected and separated from the data, and displaying the remaining data without the at least one complete stylus stroke which has been selected and separated.

11. A method according to claim 10, wherein the stylus stroke data includes samples taken at periodic intervals, the samples representing continuous stylus motion, each sample associated with a time of entry, and
5 wherein:

selecting relative time parameters includes selecting contiguous stylus data within one stroke.

12. A method according to claim 9, wherein the relative times represent time of associated data entry, and wherein:

5 selecting relative time parameters includes
displaying data according to time of entry and
providing an operator with ability to play the
data forward with respect to time of entry, such
that the display monitor and computer processing
device display to the operator simulated entry
10 of data at approximately the rate at which data
was originally entered.

13. A method according to claim 9, further employing a second graphics display window, wherein said method further comprises:

5 placing the subset of data into the second
graphics display window; and

displaying in the second graphics display window
the subset of data, but not the remaining data.

14. A method according to claim 13, wherein said method further includes:

5 providing an operator with ability to copy a
second subset of data from the first graphics
display window to the second graphics display
window without removing the second subset of
data from the first graphics display window.

15. A method according to claim 9, wherein the selecting, separating and placing are performed under

the control of an operator via controls including play, mark and cut.

16. A method according to claim 9, wherein the display of data upon at least one of the graphics display windows is performed under the control of an operator via controls including play forward, play
5 backward and pause.

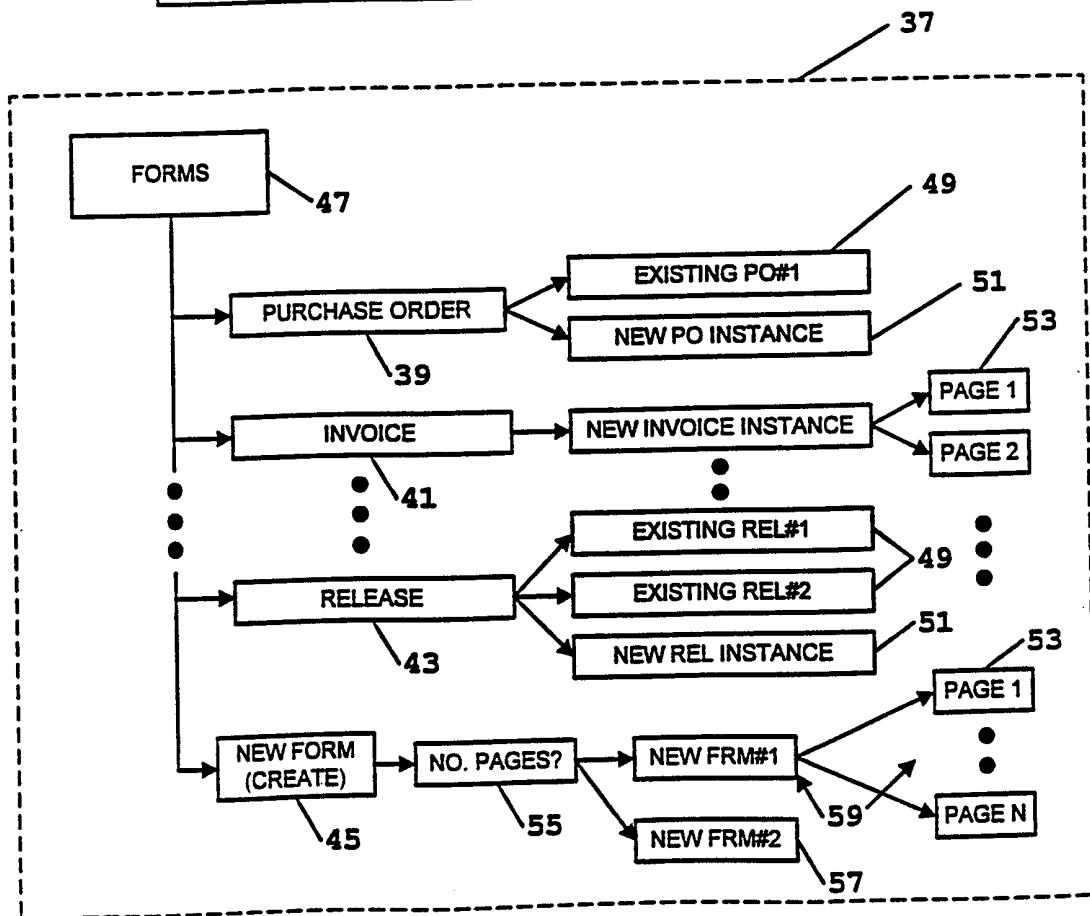
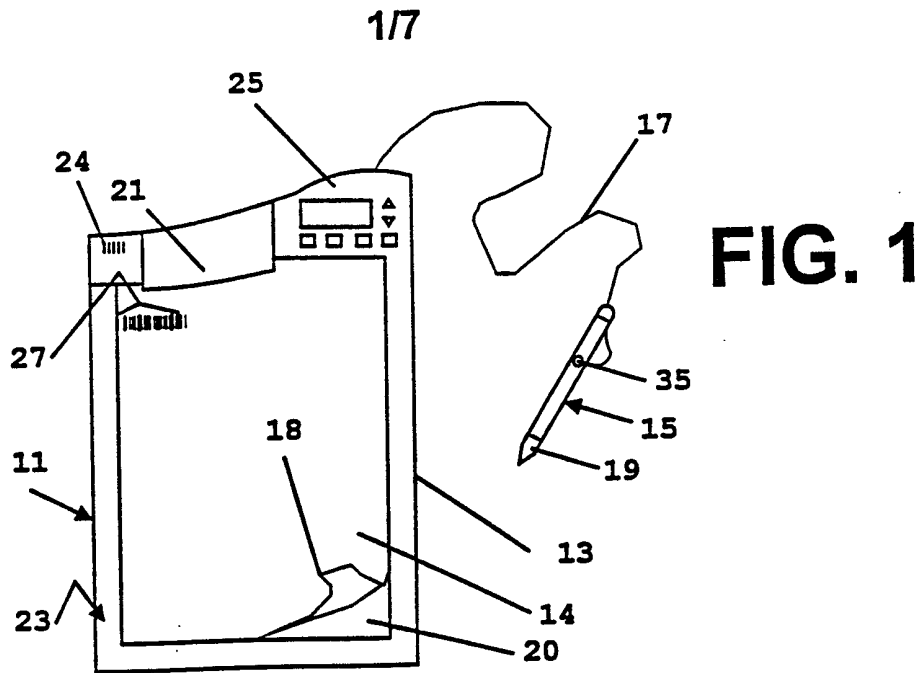

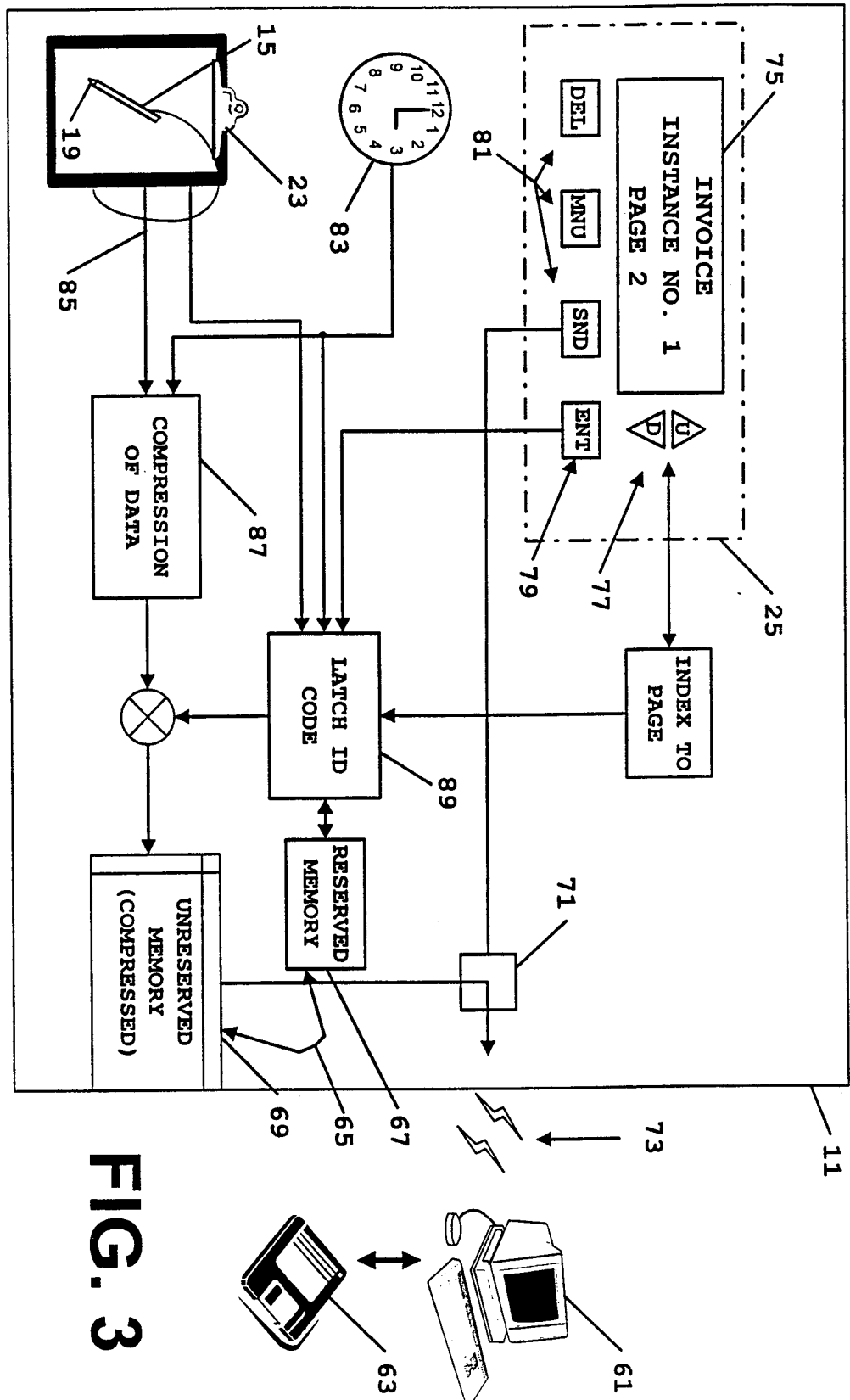

FIG. 3

3/7

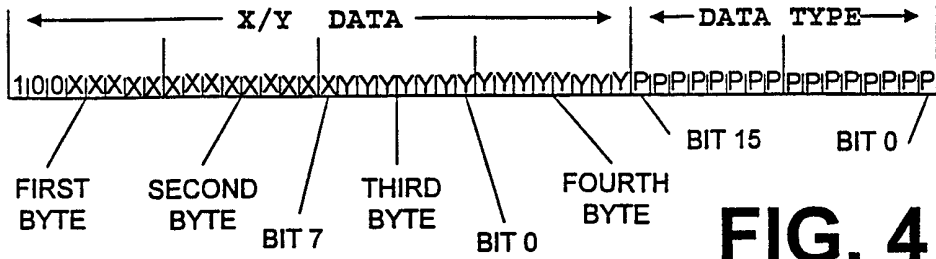

FIG. 4

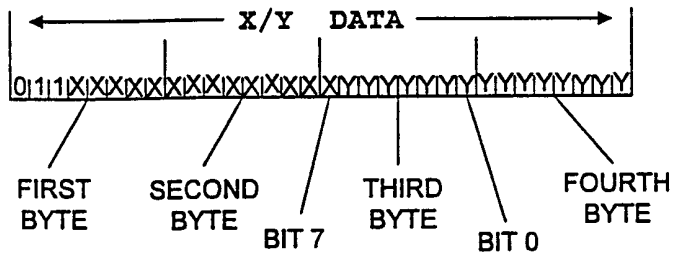

FIG. 5

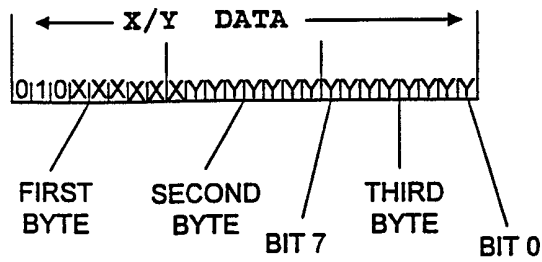

FIG. 6

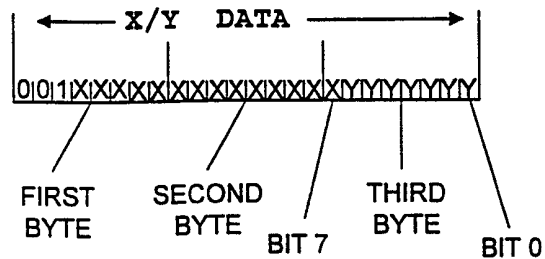

FIG. 7

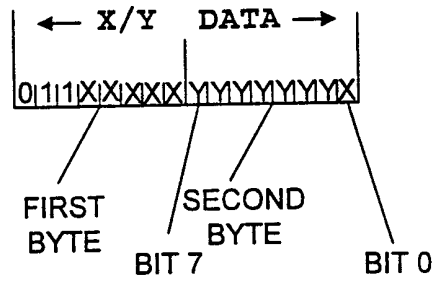

FIG. 8

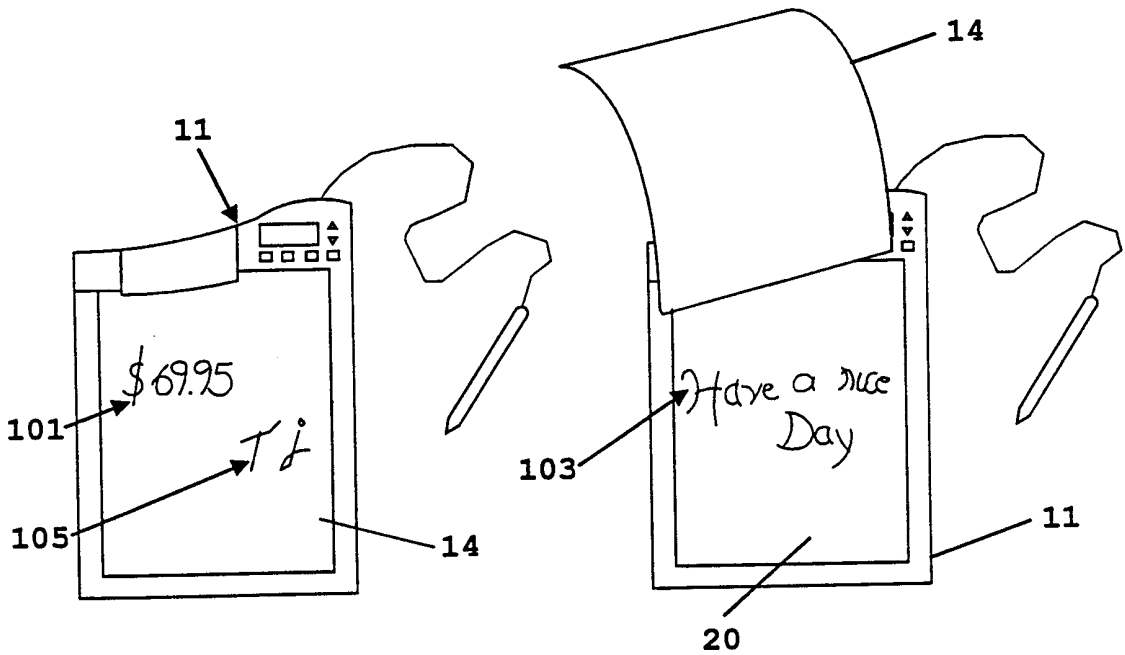

FIG. 9

FIG. 10

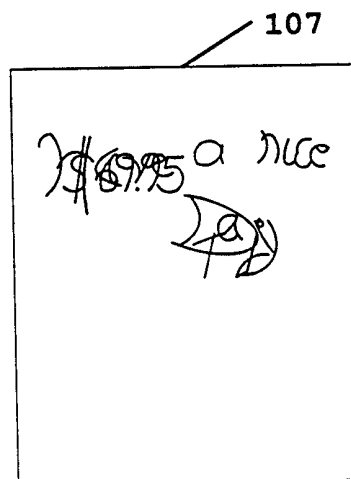

FIG. 11

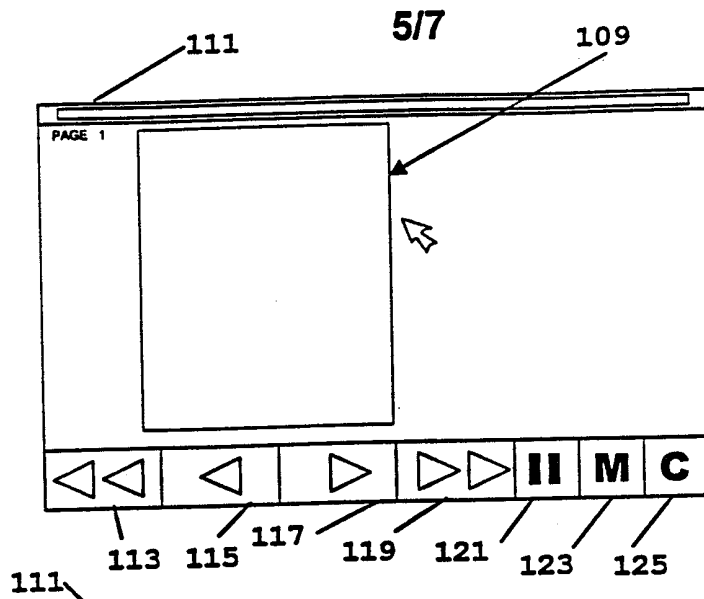

FIG. 12

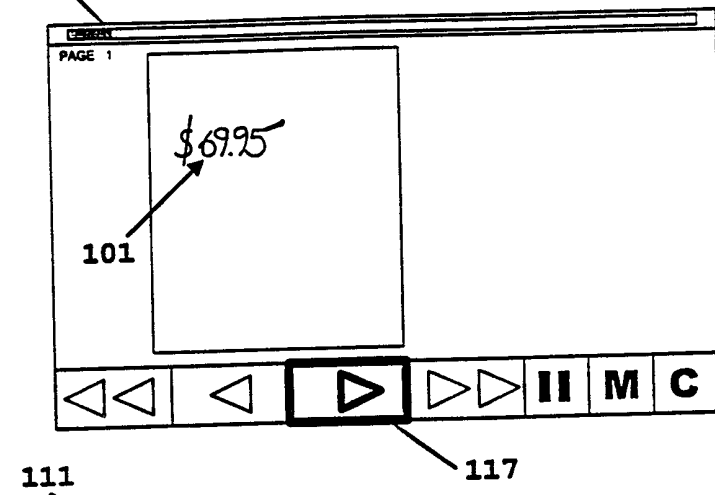

FIG. 13

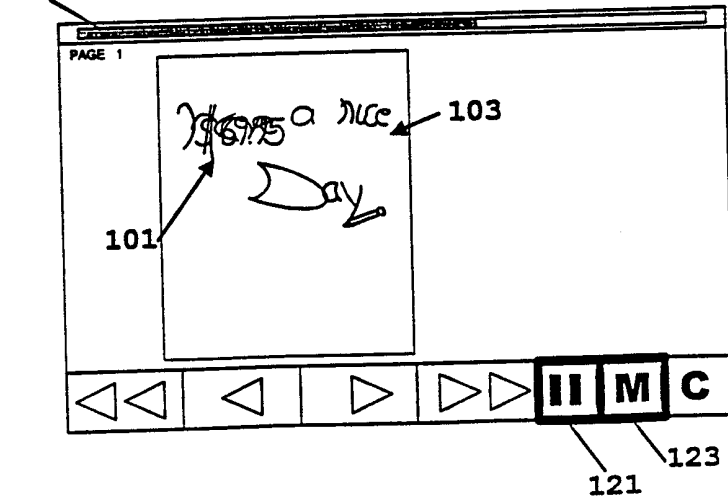

FIG. 14

6/7

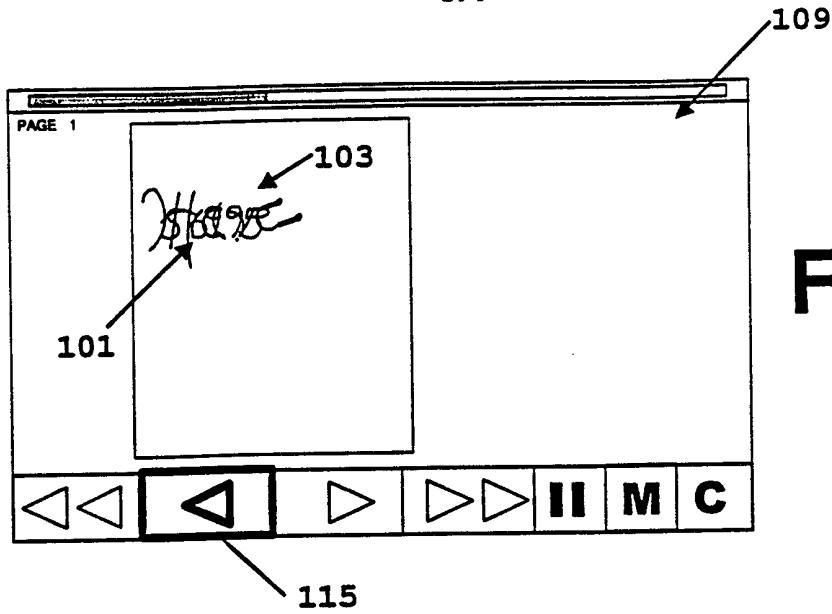

FIG. 15

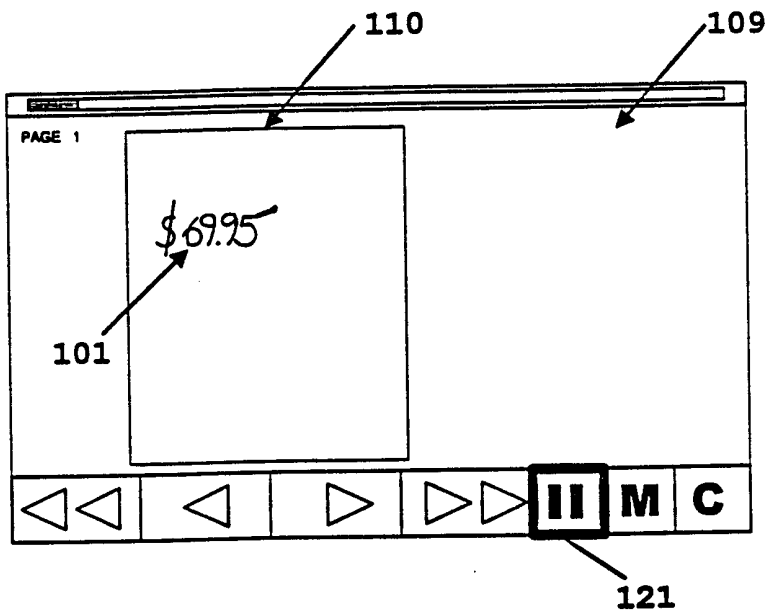

FIG. 16

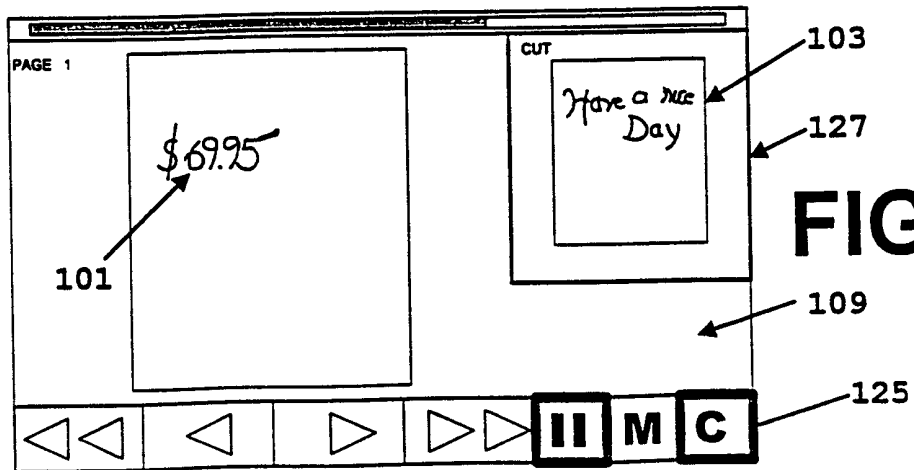

FIG. 17

717

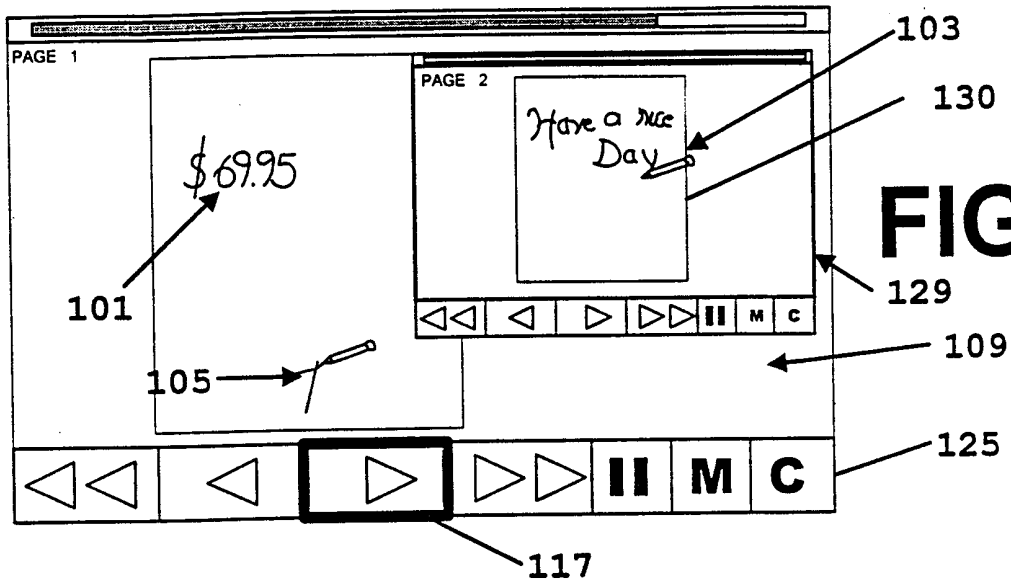

FIG. 18

INTERNATIONAL SEARCH REPORT

International Application No

PCT/US 98/22874

A. CLASSIFICATION OF SUBJECT MATTER
 IPC 6 G06F3/033 G06F17/24

According to International Patent Classification (IPC) or to both national classification and IPC

B. FIELDS SEARCHED

Minimum documentation searched (classification system followed by classification symbols)

IPC 6 G06F

Documentation searched other than minimum documentation to the extent that such documents are included in the fields searched

Electronic data base consulted during the international search (name of data base and, where practical, search terms used)

C. DOCUMENTS CONSIDERED TO BE RELEVANT

Category ^o	Citation of document, with indication, where appropriate, of the relevant passages	Relevant to claim No.
X	EP 0 774 708 A (AT & T CORP) 21 May 1997 see column 3, line 46 - column 4, line 20 see column 5, line 3 - column 8, line 31 see column 10, line 25 - column 12, line 10 see column 12, line 35-48 see figures 1-11	1-6,9-14
Y	---	7,8,15, 16
Y	EP 0 618 538 A (SONY CORP) 5 October 1994 see abstract see column 7, line 55 - column 11, line 14 see figures 1,3-20	7,8,15, 16
A	--- -/--	1-6,9-14



Further documents are listed in the continuation of box C.



Patent family members are listed in annex.

^o Special categories of cited documents :

- "A" document defining the general state of the art which is not considered to be of particular relevance
- "E" earlier document but published on or after the international filing date
- "L" document which may throw doubts on priority claim(s) or which is cited to establish the publication date of another citation or other special reason (as specified)
- "O" document referring to an oral disclosure, use, exhibition or other means
- "P" document published prior to the international filing date but later than the priority date claimed

- "T" later document published after the international filing date or priority date and not in conflict with the application but cited to understand the principle or theory underlying the invention
- "X" document of particular relevance; the claimed invention cannot be considered novel or cannot be considered to involve an inventive step when the document is taken alone
- "Y" document of particular relevance; the claimed invention cannot be considered to involve an inventive step when the document is combined with one or more other such documents, such combination being obvious to a person skilled in the art.
- "&" document member of the same patent family

Date of the actual completion of the international search

1 March 1999

Date of mailing of the international search report

08/03/1999

Name and mailing address of the ISA

European Patent Office, P.B. 5818 Patentlaan 2
 NL - 2280 HV Rijswijk
 Tel. (+31-70) 340-2040, Tx. 31 651 epo nl,
 Fax: (+31-70) 340-3016

Authorized officer

Baldan, M

INTERNATIONAL SEARCH REPORT

International Application No
PCT/US 98/22874

C.(Continuation) DOCUMENTS CONSIDERED TO BE RELEVANT		
Category	Citation of document, with indication, where appropriate, of the relevant passages	Relevant to claim No.
A	<p>US 5 625 833 A (DONOGHUE KAREN ET AL) 29 April 1997 see column 6, line 16 - column 8, line 20 see column 9, line 9-19 see column 15, line 59 - column 16, line 32 see column 18, line 12-31 see column 21, line 31-57 see column 27, line 37-65 see column 32, line 24-38 see figures 1A-2B,8 ---</p>	1-6,9-14
A	<p>US 5 564 005 A (WEBER KARON A ET AL) 8 October 1996 see abstract see column 4, line 33 - column 7, line 11 see column 12, line 28 - column 15, line 50 see column 19, line 44 - column 24, line 15 see column 28, line 12-50 see figures 1-14A ---</p>	1-14
A	<p>US 5 590 257 A (FORCIER MITCHELL D) 31 December 1996 see column 5, line 15-40 see column 9, line 3 - column 11, line 56 see column 17, line 1-16 see column 43, line 20 - column 46, line 6 see figures 1,3-3B,12D ---</p>	1,9
A	<p>US 5 629 499 A (FLICKINGER DANIEL ET AL) 13 May 1997 cited in the application see column 2, line 27 - column 5, line 19 see figures 1,4,5 -----</p>	1,9

INTERNATIONAL SEARCH REPORT

Information on patent family members

International Application No

PCT/US 98/22874

Patent document cited in search report	A	Publication date		Patent family member(s)	Publication date
EP 0774708	A	21-05-1997		US 5838819 A	17-11-1998
				CA 2184212 A	15-05-1997
				JP 9190265 A	22-07-1997
EP 0618538	A	05-10-1994		JP 7134763 A	23-05-1995
				US 5493557 A	20-02-1996
US 5625833	A	29-04-1997		US 5680636 A	21-10-1997
				AT 161979 T	15-01-1998
				AT 157467 T	15-09-1997
				AU 623149 B	07-05-1992
				AU 3691689 A	12-12-1989
				AU 624835 B	25-06-1992
				AU 3745989 A	12-12-1989
				AU 624837 B	25-06-1992
				AU 3757889 A	12-12-1989
				AU 624838 B	25-06-1992
				AU 3777689 A	12-12-1989
				CA 1326560 A	25-01-1994
				CA 1322610 A	28-09-1993
				CA 1334874 A	21-03-1995
				CA 1327082 A	15-02-1994
				DE 68928276 D	02-10-1997
				DE 68928276 T	15-01-1998
				DE 68928531 D	12-02-1998
				DE 68928531 T	16-04-1998
				DE 68928737 D	20-08-1998
				DK 22290 A	26-01-1990
				DK 22390 A	26-03-1990
				DK 22490 A	26-01-1990
				EP 0377698 A	18-07-1990
				EP 0370101 A	30-05-1990
				EP 0394379 A	31-10-1990
				EP 0374241 A	27-06-1990
				EP 0579337 A	19-01-1994
				EP 0570083 A	18-11-1993
				JP 2504439 T	13-12-1990
				JP 2504564 T	20-12-1990
				JP 3500943 T	28-02-1991
				MX 171579 B	08-11-1993
	MX 171580 B	08-11-1993			
	MX 171581 B	08-11-1993			
	MX 171582 B	08-11-1993			
	WO 8911693 A	30-11-1989			
	WO 8911694 A	30-11-1989			
	WO 8911695 A	30-11-1989			
	WO 8911696 A	30-11-1989			
	US 5442795 A	15-08-1995			
	US 5161213 A	03-11-1992			
	US 5355447 A	11-10-1994			
US 5564005	A	08-10-1996		CA 2129078 A,C	16-04-1995
				JP 7192118 A	28-07-1995
US 5590257	A	31-12-1996		US 5220649 A	15-06-1993
				US 5231698 A	27-07-1993
				WO 9216900 A	01-10-1993

INTERNATIONAL SEARCH REPORT

Information on patent family members

International Application No

PCT/US 98/22874

Patent document cited in search report	Publication date	Patent family member(s)	Publication date
US 5629499 A	13-05-1997	CN 1126342 A	10-07-1996
		EP 0655674 A	31-05-1995
		JP 7200134 A	04-08-1995
