



Europäisches Patentamt  
European Patent Office  
Office européen des brevets



(11) **EP 0 963 008 A3**

(12) **EUROPEAN PATENT APPLICATION**

(88) Date of publication A3:  
**18.04.2001 Bulletin 2001/16**

(51) Int. Cl.<sup>7</sup>: **H01R 13/436, H01R 13/447**

(43) Date of publication A2:  
**08.12.1999 Bulletin 1999/49**

(21) Application number: **99109391.5**

(22) Date of filing: **02.06.1999**

(84) Designated Contracting States:  
**AT BE CH CY DE DK ES FI FR GB GR IE IT LI LU  
MC NL PT SE**  
Designated Extension States:  
**AL LT LV MK RO SI**

(72) Inventors:  
• **Ito, Osamu**  
**Yokkaichi-city, Mie 510-8503 (JP)**  
• **Ito, Mitsuru**  
**Yokkaichi-city, Mie 510-8503 (JP)**

(30) Priority: **04.06.1998 JP 15607598**  
**09.03.1999 JP 6196999**

(74) Representative:  
**Müller-Boré & Partner**  
**Patentanwälte**  
**Grafinger Strasse 2**  
**81671 München (DE)**

(60) Divisional application:  
**01101193.9**

(71) Applicant:  
**Sumitomo Wiring Systems, Ltd.**  
**Yokkaichi-City, Mie, 510-8503 (JP)**

(54) **A connector and a cap therefor**

(57) To provide a cap capable of preventing the deformation and breakage of tabs in a hood-less type male connector.

A cap 3 is integrally made of a synthetic resin, and a cap main body 12 for surrounding tabs projecting from the front end surface of a connector housing 1 is formed at a front part of the cap 3. Behind the cap main body 12 is formed an engaging portion 11 for engaging the cap 3 with the connector housing 1. The engaging portion 11 is comprised of a tubular portion 11A to be mounted on a front end portion of the connector housing 1 and a pair of elastic pieces 11B extending from the left and right side walls of the tubular portion 11A. Further, retainer protecting ribs 16 project upward and downward from a rear end of the tubular portion 11A so as to prevent retainers 8 in their standby positions from shifting to their locking positions.

**FIG. 3**

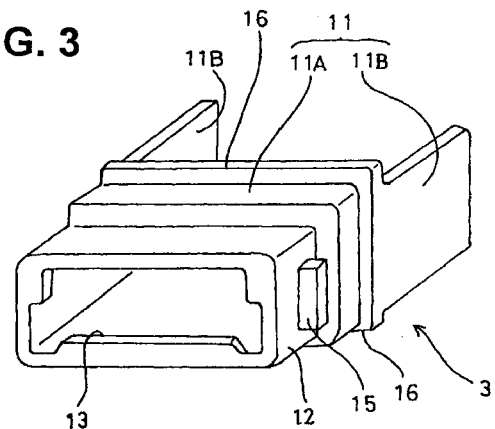

**EP 0 963 008 A3**



European Patent  
Office

EUROPEAN SEARCH REPORT

Application Number  
EP 99 10 9391

DOCUMENTS CONSIDERED TO BE RELEVANT			
Category	Citation of document with indication, where appropriate, of relevant passages	Relevant to claim	CLASSIFICATION OF THE APPLICATION (Int.Cl.6)
X	US 5 556 288 A (ISHII TAKASHI ET AL) 17 September 1996 (1996-09-17)	1,2,5-9	H01R13/436 H01R13/447
Y	* column 6, line 14 - column 7, line 57 * ---	3	
X	US 5 145 385 A (TAKANO TSUNESUKE) 8 September 1992 (1992-09-08)	1,2,6,8, 9	
	* column 4, line 27 - column 5, line 54 * ---		
Y	US 5 730 627 A (OKABE TOSHIKI) 24 March 1998 (1998-03-24)	3	
	* figure 5 * ---		
Y	US 3 990 759 A (CROWE TERENCE ALFRED) 9 November 1976 (1976-11-09)	3	
	* figures 1,6 * -----		
The present search report has been drawn up for all claims			TECHNICAL FIELDS SEARCHED (Int.Cl.6)
			H01R
Place of search	Date of completion of the search	Examiner	
THE HAGUE	27 February 2001	Bertin, M	
CATEGORY OF CITED DOCUMENTS			
X : particularly relevant if taken alone Y : particularly relevant if combined with another document of the same category A : technological background O : non-written disclosure P : intermediate document		T : theory or principle underlying the invention E : earlier patent document, but published on, or after the filing date D : document cited in the application L : document cited for other reasons ----- & : member of the same patent family, corresponding document	

EPO FORM 1503 03/82 (P04C01)

**ANNEX TO THE EUROPEAN SEARCH REPORT  
ON EUROPEAN PATENT APPLICATION NO.**

EP 99 10 9391

This annex lists the patent family members relating to the patent documents cited in the above-mentioned European search report. The members are as contained in the European Patent Office EDP file on  
The European Patent Office is in no way liable for these particulars which are merely given for the purpose of information.

27-02-2001

Patent document cited in search report	Publication date	Patent family member(s)	Publication date
US 5556288 A	17-09-1996	JP 2905360 B	14-06-1999
		JP 6333641 A	02-12-1994
US 5145385 A	08-09-1992	DE 4119685 A	09-01-1992
		GB 2246248 A, B	22-01-1992
		HK 52795 A	13-04-1995
		IT 1251096 B	04-05-1995
US 5730627 A	24-03-1998	JP 9007676 A	10-01-1997
US 3990759 A	09-11-1976	ZA 7403170 A	27-08-1975
		AU 8122975 A	18-11-1976
		GB 1504173 A	15-03-1978

EPO FORM P0469

For more details about this annex : see Official Journal of the European Patent Office, No. 12/82