

[54] AUTOMATIC BALANCING DEVICE

322,069 7/1885 Rothe ..... 74/573  
331,450 12/1885 Rothe ..... 74/573

[75] Inventor: Johannes Lagerwey, Leidschendam, Netherlands

[73] Assignee: Reactor Centrum Nederland, The Hague, Netherlands

[22] Filed: Apr. 8, 1971

[21] Appl. No.: 132,505

Primary Examiner—Charles J. Myhre  
Assistant Examiner—F. D. Shoemaker  
Attorney, Agent, or Firm—Cushman, Darby & Cushman

[30] Foreign Application Priority Data

Apr. 1, 1970 Netherlands ..... 7006072

[52] U.S. Cl. .... 74/573, 233/23 A

[51] Int. Cl. .... F16f 15/32

[58] Field of Search ..... 74/573; 233/23 A; 68/23.1, 68/23.2, 23.3

[57] ABSTRACT

An automatic self-adjusting balancing device for a member mounted for rotation around a vertical spindle comprising a hollow housing rotating with said member and having an inner circular wall component which is coaxial with the spindle; at least two loose rotational bodies within said housing, each body having a circular rim edge which spans said vertical spindle, said rim edge having a smaller diameter on its upper side than on its lower side, at least one of said bodies being tiltable about its larger diameter against said inner wall component of said housing.

[56] References Cited

UNITED STATES PATENTS

R7,455 1/1877 Fesca ..... 74/573 X

6 Claims, 8 Drawing Figures

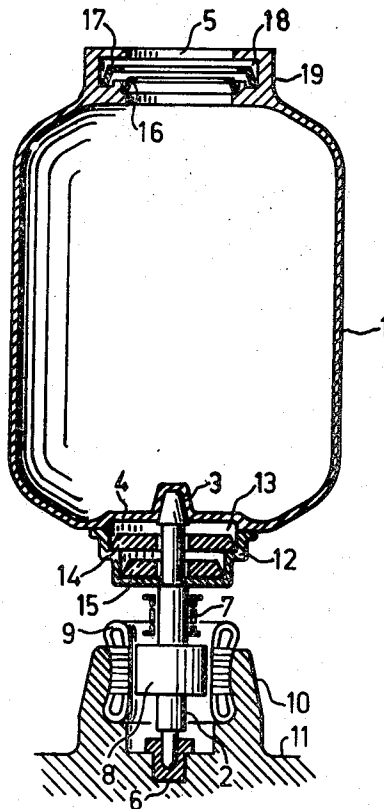

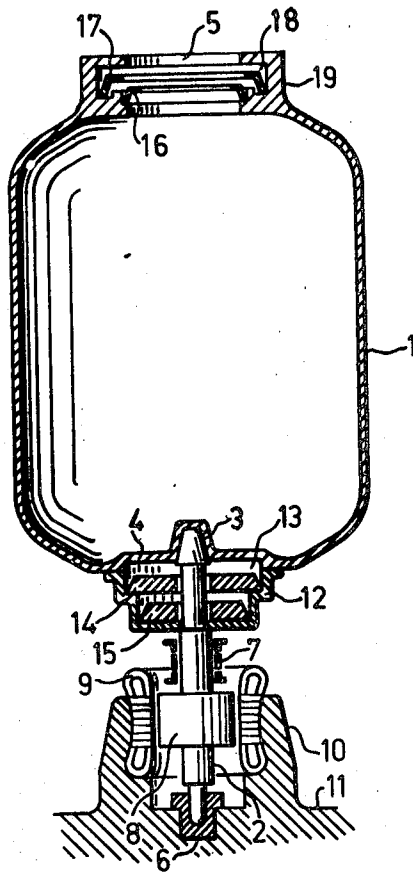

fig. 1

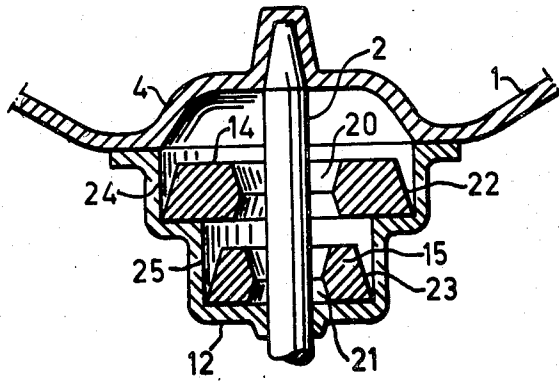

fig.2

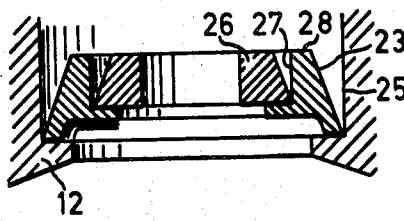

fig.3

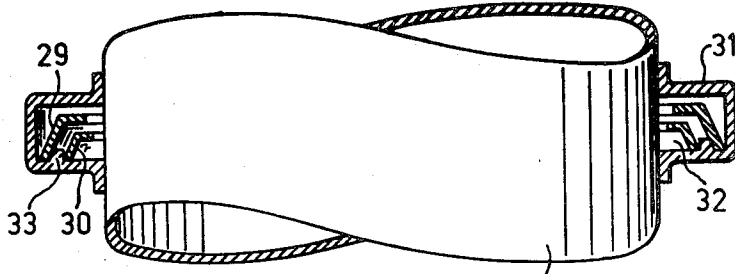

fig. 4



fig. 5

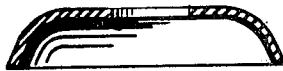

fig. 6

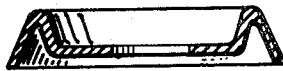

fig. 7

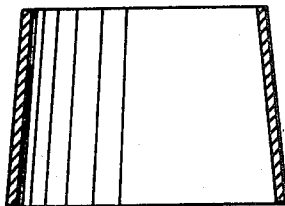

fig. 8

## AUTOMATIC BALANCING DEVICE

The invention relates to an automatic selfadjusting balancing device for a rotational body that can rotate around a vertical spindle, consisting of a hollow ring-shaped housing in which a number of loose rotational bodies are incorporated, each having at least one limiting rim edge, which surround or span the said vertical spindle and which, on rotation of the housing, can move outwards under the action of the centrifugal force.

The prior art balancing devices of this type hitherto showed the drawback that the rotational bodies, when moving outwards, came to rest with much friction in the moved-out position. The result of this was that these prior-art balancing devices were still not sufficiently sensitive to permit of their advantageous use in all cases. In particular, this balancing device did not come up to expectations in the case of a somewhat higher speed of revolution.

According to the invention at least one rotational body has at the circumference of its outer rim edge a smaller diameter on the upper side than on the underside. This shaping enables the rotational body to tilt around a point on its circumference that is situated on the larger diameter. Especially if, according to a preferred embodiment, at least one outer rim edge is externally frustum-shaped, such rotational body when in the moved-out position can be kept in linear contact with the inner wall of the hollow ring-shaped housing.

As the rotational body, when moving outwards, suddenly passes into its new position, it can with rolling friction perform oscillations around a middle position of equilibrium. This rolling friction makes the balancing device according to the invention highly sensitive.

The number of rings assembled in a hollow ring-shaped housing is at least two, although three or more rings may be used.

The rotational bodies referred to in the above may consist, for instance, of rings or disks. These rings or disks need not, however, have a flat shape but may form parts of convex dish walls.

According to a further preferred embodiment the rotational bodies are executed as rings, which rings at their largest diameter are spanned, with slight clearance, by a wall portion of the ring-shaped housing.

This clearance should be just sufficient to allow the rings to move outwards to the required end position. An advantage gained through the possibility of using slight clearance is that a highly compact construction becomes possible, especially if a further number of the rotational bodies are made hollow so that externally positioned bodies span the internally situated bodies.

If light-weight constructions are aimed at, it is advisable to make the rotational bodies with a dish-shaped wall. In a specific case the rotational body itself may have the shape of a dish.

In this patent application the term "rings" occurring in the foregoing may also mean a hoop-shaped or sleeve-shaped construction.

A number of typical embodiments of the invention are further elucidated in the following drawings, in which:

FIG. 1 depicts a vertical cross-section of a centrifuge in which the invention is applied;

FIG. 2 shows in vertical cross-section a detail of a balancing device;

FIG. 3 shows a variant of such balancing device;

FIG. 4 shows a balancing device which is suitable for containing a tube or vessel of fairly large diameter;

FIGS. 5 to 8 inclusive show variants of the rotational bodies which can be used in the balancing device according to the invention.

Reference number 1 in FIG. 1 represents a centrifuging drum having a vertical spindle 2 on its underside. This spindle is rigidly fixed at 3 to the bottom 4 of the centrifuging drum. The centrifuging drum 1 has on its upper end an aperture 5 through which materials can be passed into or out of the centrifuging drum. Spindle 2 of the centrifuge has on its underside a supporting bearing 6. Moreover, an additional supporting bearing may be fitted at 7 if necessary. Mounted on spindle 2 is the rotor 8 of an electric motor running within a stator 9 which is fixed via construction 10 to housing 11 of the centrifuge, which housing is not further indicated. Fitted to the underside of the bottom 4 is a lid 12, so positioned that a space 13 is formed within which two balancing rings 14 and 15 are mounted.

The figure shows, moreover, that it is also possible to mount balancing rings on the upper end of the drum 1. These rings 16 and 17 are positioned inside an annular cavity 18 recessed inside a thickened edgelike part 19 of the wall of the centrifuging drum. It is, of course, possible to close this annular space entirely, so that there is no risk that the material to be processed in the centrifuge, for instance sugar, might become lodged between the balancing rings. This closure facility is, however, not illustrated in the drawing, since FIG. 1 is intended as a diagrammatic representation.

FIG. 2 clearly shows the way in which rings 14 and 15 may be formed. Each ring is provided with a central aperture 20 and 21 respectively, through which passes the spindle 2 by means of which the centrifuging drum is driven.

Each ring is given a frustum-shaped finish on its outer side, so that surface areas 22 and 23 respectively are formed. As soon as the balancing device comes into action the balancing rings proceed to tilt in such a way that near the tilting point a linear contact is established between the outer sides 22 and 23 and the inner side of the wall components 24 and 25 respectively of the hollow annular housing 12 in which the rings are positioned.

Again in FIG. 3, two balancing rings are mounted, but now in such a manner that the inner balancing ring 26 is situated in a cylindrical cavity 27 of the outer balancing ring 28.

In FIG. 4, large hoop-shaped rings 29 and 30 are used in the balancing device 31. The bottom of the hollow annular housing 32 has a ridge 33 against which the inner ring 30 can rest in such a way that tilting of ring 30 around a point on the inner side of ridge 33 is possible. This figure clearly shows that the balancing device according to the invention can be mounted in a simple manner on the outer side of cylindrical rotational bodies 34 of fairly large diameter. If desired, such balancing device 31 may be mounted at several points on a rotational body, so that damping can be fully controlled even with longer rotational bodies.

FIGS. 5, 6, 7 and 8 show a further number of possible solids of possible rotational bodies, whilst FIG. 5 illustrates a dish with a frustum-shaped outer edge, and

3

4

FIG. 6 shows an inverted dish in which the outer side near the bend is somewhat rounded. FIG. 7 illustrates a dish whose bottom is recessed. The recess may be formed in such a way that it influences the position of the centre of gravity. It will be evident that the position of the centre of gravity, viz. the distance of the centre of gravity from a ring or disk, measured in the vertical direction to a supporting surface, is a matter of great importance to the working of the present balancing device. Indeed, the whole operation of the device is based on the fact that by tilting a rotational body its centre of gravity, which at first was centrally situated, shifts towards the outer side. As soon as this centre of gravity is situated to a certain distance from the axis of rotation, the body can perform its balancing action.

FIG. 8 illustrates a sleeve-like body which can likewise be used as a balancing body.

It will be clearly evident from the foregoing that the rotational bodies may be given different shapes, so that a constructor wishing to use this balancing device will in practically every case be able to mount these balancing bodies in his existing constructions.

What I claim is:

1. An automatic self-adjusting balancing device for a member mounted for rotation around a vertical spindle

comprising a hollow housing rotating with said member and having an inner circular wall component which is coaxial with the spindle; at least two loose rotational bodies within said housing, each body having a circular rim edge which spans said vertical spindle, said rim edge having a smaller diameter on its upper side than on its lower side, at least one of said bodies being tiltable about its larger diameter against said inner wall component of said housing.

2. A balancing device as in claim 1 wherein the rim edge of said one body is externally frustum-shaped.

3. A balancing device as in claim 1 wherein said one body is a ring and wherein there is a slight clearance between the largest diameter of said ring and said inner wall component of said housing.

4. A balancing device as in claim 1 wherein at least one of said bodies is a ring and wherein another of said bodies resides within said one body.

5. A balancing device as in claim 1 wherein at least one of said bodies is dish-shaped.

6. A balancing device as in claim 1 wherein said bodies are rings surrounding the spindle, said rings having frustum-shaped rim edges.

\* \* \* \* \*

30

35

40

45

50

55

60

65