

A. C. PLATT.

Machine for Labeling and Varnishing Fruit Cans and other Cylindrical Packages.
No. 106,724.

Patented Aug. 23, 1870.

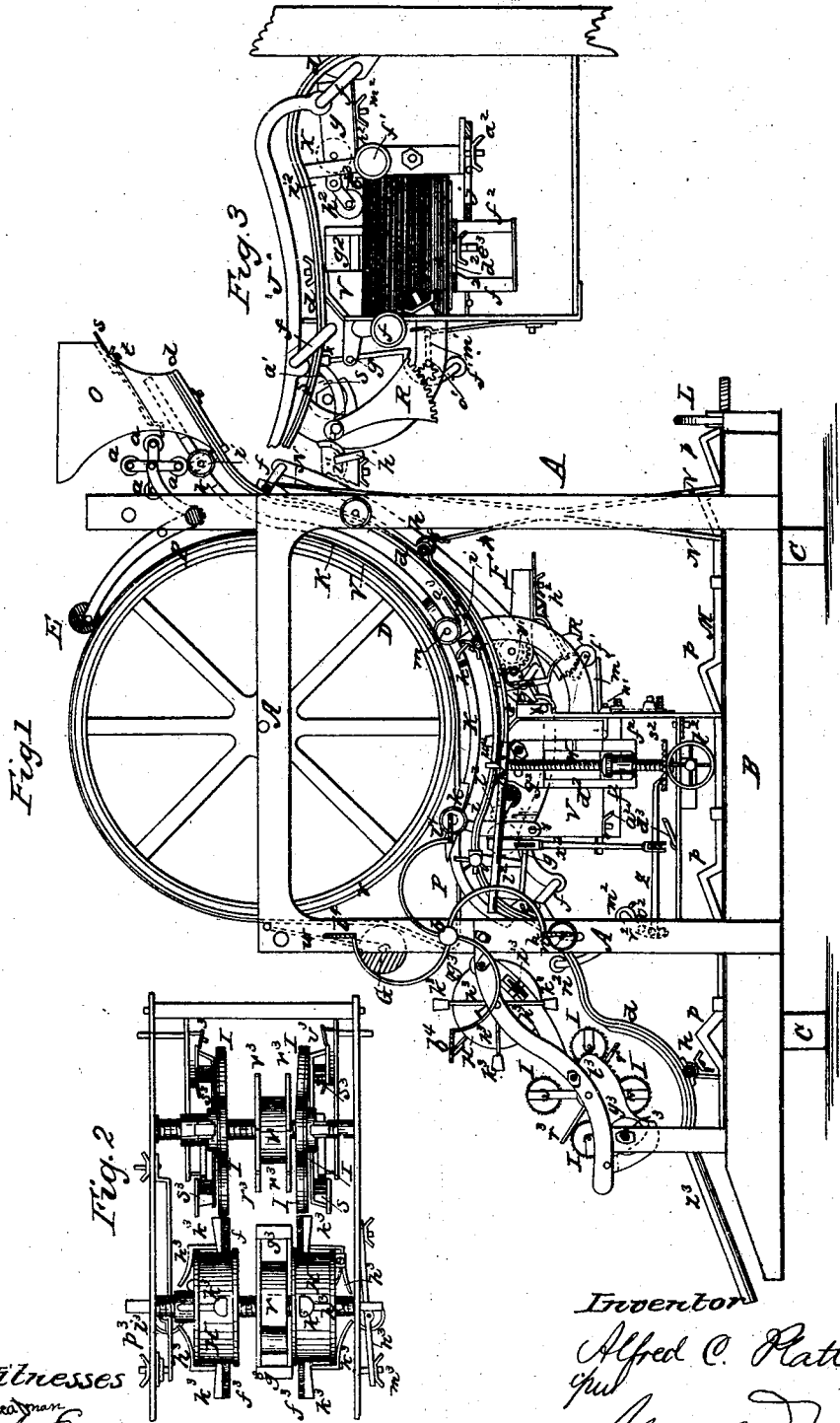

Witnesses
Attest
J. H. Covert

Inventor
Alfred C. Platt
per
Alexander Massey
Attys

A. C. PLATT.

Machine for Labeling and Varnishing Fruit Cans and other Cylindrical Packages.

No. 106,724.

Patented Aug. 23, 1870.

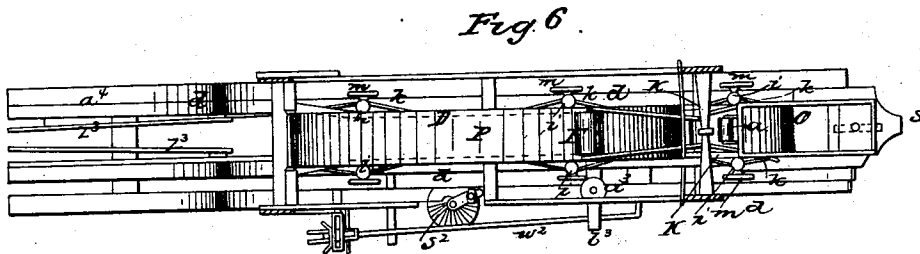
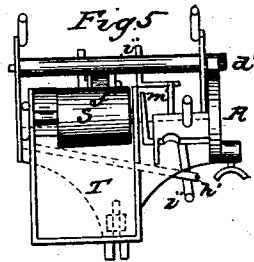
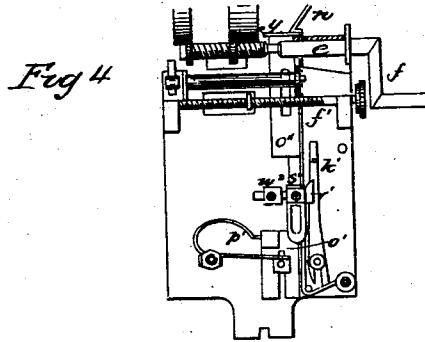

witnesses
Al. Watson
Ed. Covert

Inventor
Alfred C. Platt
per
Alexander T. Massey
Atty

United States Patent Office.

ALFRED C. PLATT, OF SANDUSKY, OHIO.

Letters Patent No. 106,724, dated August 23, 1870.

IMPROVED MACHINE FOR VARNISHING AND LABELING FRUIT-CANS AND OTHER CYLINDRICAL PACKAGES.

The Schedule referred to in these Letters Patent and making part of the same

To all whom it may concern:

Be it known that I, ALFRED C. PLATT, of Sandusky, in the county of Erie and in the State of Ohio, have invented a new and useful Machine for Labeling and Varnishing Fruit-Cans and other Cylindrical Packages; and I do hereby declare that the following is a full, clear, and exact description thereof, reference being had to the accompanying drawing and to the letters of reference marked thereon, making a part of this specification.

The nature of my invention consists in the construction and arrangement of a "machine for labeling and varnishing fruit-cans, and other cylindrical packages," which machine is operated by the weight of the cans passing through the same.

In order to enable others skilled in the art to which my invention appertains to make and use the same, I will now proceed to describe its construction and operation, referring to the annexed drawing, in which—

Figure 1 is a side elevation of the entire machine;

Figure 2 is a plan view of the varnishing mechanism;

Figure 3 is a side view of the label-holder with the mechanism immediately connected therewith;

Figure 4 is a view of the end-plate of the label-holder;

Figure 5 is a plan view of the paste-box; and

Figure 6 is a plan view of the entire machine, with the varnishing mechanism removed.

The demand for canned goods has become so great, that, in the haste to secure fruit in its season, cans accumulate in great numbers awaiting shipment, previous to which they must all be labeled, to designate the kind of goods they contain, and are varnished, where not covered with the label, to improve their appearance and prevent the exposed edges of the tin from rusting. This work has heretofore been done by the slow, tedious, and expensive method of hand-work, and there is a great demand, among packers, for some means to facilitate this part of the business. The hereinafter-described machine meets this demand, as it greatly facilitates and cheapens this part of the operation.

A represents the frame-work, supported on the bed-piece B, which rests on cross-pieces C C, said frame-work sustaining the elastic wheel D, the eccentric wheel E, and regulator *a*, a small wheel, *b*, the weight-wheel G, and the varnish-reservoirs H H and brushes I I, and serves to guide and hold in position, when at rest, the track or ways, in its proximity to the wheel D and brushes I I, as will be hereinafter described.

d d represent the track, which may be made by curving, to the proper shape, three small bars of iron, or other suitable material, two of which are rebated

about one-fourth of an inch from the inner side, and from the top nearly to the bottom or under edge. This rebate forms the ways or track for the cans to run on and admit the labels between. The sides are the guides, to direct them in a straight course.

From one of the rebated bars *d* to the plain one on the opposite side, run three screw-rods, *e e*, with cranks, *f f*, and two rods, *g g*, without screws or cranks.

One of the rebated bars is adjustable, and has on its under side attached screw-nuts, through which the screw-rods *e e* pass, and has, also, bands or loops, containing the set-screws *h h*, through which bands the rods *g g* pass.

To adjust the track to the length of the can, the set-screws *h h* being loosened, the adjustable rebated bar *d* is moved the proper distance by a simultaneous turning of the screw-rods *e e* by the connecting-rod J, connecting the three cranks *f f*. For a more nice adjustment of any particular position of the track, this connecting-rod is removed, when any screw-rod may be adjusted separately. Cans nominally of a size vary a trifle, and these lower guides are set so as to just clear the longest. When in the proper place, the movable bar *d* is secured by the set-screws *h h*.

Upon the rebated bars forming the track, supported by the standards *i i*, are the independently-adjustable spring guides K K.

These work in slots near the top of the standards *i i*, and are pressed against the ends of the cans by the springs *k k*, and are adjusted by the thumb-screws *m m*, working upon the screw-bolts, which, attached at one end to the guides K, pass through the springs *k k* and the standards at the back of the slots.

While the lower guides *d d* are adjusted to the ends of the longest cans of any nominal size, these independent spring guides are adjusted to the ends of the shortest cans, so that, when they are so short as to have too much lateral play between the lower guides, they will guide them straight forward, and thereby secure an even and smooth laying on of the label. It is recommended not to make a very close adjustment of these guides, except between the two lower standards, where the label is applied, as, at the upper part of the track, close adjustment is unnecessary, and would increase friction.

The spring guides K K stop at the varnishing-reservoirs H H, as their continuance beyond them would interfere with the brushes on said reservoirs, and is unnecessary, as these brushes themselves guide the cans. At the lower set of brushes the stationary guides *d d* stop, and the cans are taken up by another track, as will be hereinafter set forth, leaving the ends of the can free for the revolving brushes I I to sweep the whole surface.

The whole track is adjusted to the diameter of the can by the screw-wheel L, which moves the wedge-bar M through openings in the standards N N.

By turning the screw-wheel, this bar is pressed forward or drawn back through these openings, and the track elevated or depressed to the desired point, where it is more firmly secured by the screw-rods *n n*, passing through the frame A.

The variation of curvature of the track to the different curves required for cans of different sized, is adjusted by the oblique slots *o o* in the frame, through which the rear set-rod *n* passes, and, by the wedges *p p* upon the sliding bar M, being of different angles from each other, thereby moving one of the standards N more than the other. These standards are joined, near the center, for mutual support, and, being elastic, spring either way, as the wedges vary them.

Perfect accuracy of adjustment of this curve is not necessary, as the main wheel D, having a very elastic periphery, will accommodate itself to any inequality of curve or can. From the label-holder downward, the track moves up and down in a vertical direction only. This, of course, does not bring the part of the track nearest vertical equally distant from the centers of the revolving reservoirs and brushes, with the part nearest horizontal, but the same distance in these parts is not necessary, and the cans are adjusted to these inequalities by the elastic bands *r r*, between the reservoirs H H, and between the brushes I I.

The feed-box O is placed at a sufficient distance above the track, at the rear end of the machine, to admit the largest cans, and its opening is adjusted to the length of the cans by the adjustment of the track as above described, one side of the feed-box being attached to the movable track-bar.

It is also adjusted to the diameter of the cans by the sliding plate *s*, which is secured in position by the set-screw *t*.

The wheel D is made large, so that less variation of curvature of the track will be required in adjusting to different sizes, and to secure more force by receiving the weight of more cans: This wheel is made elastic, for adaptation to any inequalities of track or can, and to lessen the rolling friction by this ease of adaptation.

Its elasticity may be secured by spring-arms or coiled springs, or spring bearings, or, as represented in the drawing, by soft rubber, *r*, or other elastic material, secured upon its periphery.

Around this wheel and the small wheel *b* the band P passes, and serves to complete the laying on of the label commenced by the main wheel, at the same time that it carries the can along to the varnishing-reservoirs. This band is elastic, to adapt itself to the can as it passes over the crooked part of the track from the label-holder to the varnishing-reservoirs.

Pressure upon the cans by this belt is further equalized by the weight-wheel G, resting against the band, as shown in fig. 1.

This wheel is prevented from rebounding, as the can suddenly passes through and tightens the band, by the spring supports *w w*.

The surface of the wheel G, and also of the eccentric-wheel E, is made absorbent, to take up any paste that may escape upon the band, so that it will not get upon the face of the labels.

The periphery of the main wheel D, the wheel *b*, and the band F must be made the width of the length of the longest can.

The cluster of wheels *a a*, revolving on their own centers by the friction of the can, and about a common center by the passage of the can, is operated by the eccentric friction-wheel E, rolling upon the surface of the main wheel D. The object of using this cluster, instead of one wheel, to regulate the admis-

sion of the cans, is to avoid the too sudden stopping of the cans, and consequent jarring. These wheels are covered with rubber, or other elastic material, as an additional security against this.

As the bearings of the eccentric wheel E approach the main wheel, the two wheels of the cluster that rest against the can pass gently over it, the front one dropping between it and the next can, which, with the next in the cluster, arrests the can above until another revolution of the eccentric-wheel releases it. Harmony in size and arrangement between this cluster and the eccentric wheel will prevent the jarring mentioned.

As the can approaches the label-holder it touches the paste-pad *x*, which is so adjusted as to apply paste to the can at a point which will come down about one-fourth of an inch past the end of the label, just at the edge of the clasp *y*. Care should be taken with this adjustment, as, if paste should get upon this clasp, it would adhere to the can at a point not covered by the label, and would then get upon the band, and be liable to soil the face of other labels as it came around.

It will be noticed that this method of applying the paste answers the double purpose of picking up the label, separating it from others, and causing it to adhere to the can at the same time as wanted.

The paste-pad *x* is made shorter than the width of the label, to prevent any paste getting onto any label under the top one that may project beyond it, when, if it so happened, the can would carry up more than one label.

These pads are made of different lengths, to suit the different sizes of cans, and are attached to the end of the arm *z*, as wanted, and are made to project, more or less, from this arm, so that from the same arm cans of different sizes may be pasted at such point as will come down in the same place, as indicated. The lower edge of the pad is to be placed one and three-quarter inch above the track, and about half an inch back from a line vertical with the ends of the labels for a three-pound can, four and a half inches in diameter. A pad projecting about one-fourth of an inch from this will touch a two-pound can, three and a half inches in diameter, at a point that will come down in the same place, and, projecting half an inch, will touch a one-pound can three inches in diameter at the necessary point. Each successive pad is curved back at the top more and more, to meet the shorter curve of the smaller cans.

Soon after touching the pad the can touches the arm *a'*, which is upon the shaft *b'*, on the opposite end of which is the segmental rack R, which works in the pinion *d'*.

This pinion carries the shaft *e'*, to which is attached the crank *f'*, which operates the pad-arm *z*.

This arm works through the swivel-bar *g'*, and, thus held, the half revolution of the crank *f'* brings, by an eccentric motion, the pad *x* quickly from and down out of the way of the can, and against the paste-wheel S.

Now if this pad was permitted to be immediately brought back by the spring *h'*, attached to the arm *i'*, which extends from the shaft *b'*, it would hit the can, and get paste upon it at a point that would come in contact with the belt P, and also come in collision with the clasp *y*; it, is, therefore, arrested at this point, and held by the spring-catch *k'*, which catches the arm *m'* projecting from the shaft *e'*.

The clasp *y* is a thin plate, projecting about one fourth of an inch onto the labels, and is held upon them, and holds them down by the spring-catch *n'*.

The clasp *y* is upon the top of the upright bar or shaft *o'*, and is carried upward by the spring *p'*, when not held down by the spring catch *n'*.

Now as the can passes along it presses back the spring catch *n'*, and liberates the clasp *y*, which fol-

lows the can up a sufficient distance to allow the label to pass, when the point r^1 , attached to the upright bar o^1 , presses back the spring catch k^1 , and liberates the arm m^1 upon the crank-shaft e^1 .

This now being liberated is brought back by the spring h^1 , and the arm m^1 , which was held by the catch k^1 , strikes upon the arm s^1 projecting from the upright bar o^1 , and carries the shaft or bar, with the clasp y , suddenly down upon the end of the labels, where it is again secured by the spring catch n^1 , and the pad x is carried back to its position, ready for the next can.

The paste-wheel S revolves in the paste-box T, and is made as long as the longest cans, while the different pads which play upon it are adapted to the length of the cans.

This paste-wheel is moved a little at a time by the arm t^1 , upon the end of the swivel-rod g^1 , working in the ratchet-wheel v^1 .

The label-holder V is adjusted and supported in its place by the screw-rods x^1 x^1 , and the set-screw w^1 , upon a bolt, which works in a slot, as shown in fig. 4.

The plate which forms the back side of the label-holder has arms projecting from the upper corners, through which the screw-rods x^1 x^1 pass.

To this plate the bottom y^1 is attached

From the left end of this bottom-piece projects the screw-rod, upon which the set-nut w^1 works, as above mentioned.

In the other end of the bottom y^1 is a slot, in which slides the upright adjustable end plate z^1 , held in place by the set-screw a^2 , under the bottom.

At the top of this plate are the springs b^2 , which serve to keep the labels to their place under the clasp y , even if they vary a little in length. This upright plate, and also the bottom, must be made as narrow as the narrowest labels to be used.

Above this stationary bottom, and working within the label-holder, is the movable adjustable bottom d^2 .

This bottom is moved up and down by the arms f^2 extending to the upright screw-shaft W, operated in a manner to be hereafter described.

The movable bottom d^2 is composed of two plates adjusted to the length of the labels, and centrally under them, one of said plates having a dovetailed arm, working in a dovetailed slot in the other.

To this dovetailed arm is fastened a screw-bolt, e^2 , which passes down through an oblique slot in the other plate, this latter being connected to the ends of the arms f^2 f^2 .

This slot is made oblique, so that, as the bottom d^2 is lengthened or shortened, it will be moved laterally toward the center of the label-holder.

It will be seen that, the front plate being stationary, the back plate movable, and the label-holder adjusted in length entirely at the right end, this slot must be made in an oblique direction from the front left-hand corner to the back right corner.

From the bottom and back plates project suitable screw-rods for sustaining the front plate of the label-holder.

The sliding plates g^2 , upon the back and front plates of the label-holder, are moved to the paste-roller h^2 when it is adjusted to the length of the labels.

The paste is applied to the right-hand end of the labels by the roller h^2 , which rests upon them about one inch from the end.

The label is drawn out from under this roller, receiving it and receiving paste from it as the can passes along.

This roller is supplied with paste from the large paste-wheel X, by the intermediate small wheel i^2 .

One object of these rollers is to carry the paste a sufficient distance without using too large rollers, and another is to give sufficient play to the roller to operate the regulator.

This arrangement also prevents too great a supply

of paste from getting upon the label at this, the end which overlaps the first applied, for if there was too much it would press out, and not only soil the face of the label adjoining, but get paste upon the belt, which, being carried around, would damage the faces of other labels.

The large paste-wheel X revolves in the paste-box Y, by contact with the small roller i^2 , which is moved by the paste-roller h^2 , as the label turns it.

This paste-box is adjustable to the length of the label by sliding upon the bed-plate k^2 , and is held in position by the set-screw m^2 , working in a slot on said plate.

The labels are supplied to the cans in the following manner:

As the can passes along it strikes the arm n^2 , and carries it along until it passes it when it is brought back by the spring o^2 .

This arm is attached to the shaft p^2 , upon the end of which is the crank r^2 , which works the brace Z upon the face of the grooved ratchet-disk s^2 . This disk in turning revolves the upright screw-shaft W, which carries up the arms f^2 , upon the ends of which rest the labels in the label-holder.

The wheel t^2 , working in the pinion v^2 , upon the lower end of this shaft, and operated by a crank at the other side, is for reversing this motion and bringing the movable bottom of the label-holder down to be supplied with labels.

The disk s^2 is provided with curved grooves, the radii of which are equal to the length of the brace Z.

These grooves are ratchet-shaped, the side toward the brace being sloping, while the other is abrupt or hooking, to receive the point of the brace and be carried along by it.

The shaft of the paste-roller h^2 is extended, and passes under the spring-rod w^2 . This rod is slotted in the end, and through the slot passes the end bar of the perpendicular lever x^2 , which works upon the fulcrum y^2 .

This bar is inclined from the perpendicular, and, as the rod w^2 is pressed up and let down by the action of the labels upon the paste-wheel, being guided by the bar z^2 working in the same slot, it carries the lever x^2 out or in.

This lever, by a connecting link, moves the brace Z upon the disk s^2 , nearer or further from its axis.

When brought nearer, it includes in its motion more grooves, and carries the disk further. Without this regulator, labels upon thin paper would be supplied too fast, or thick ones too slow.

The guide-bar z^2 is made adjustable, and may be set nearer to or further from a line parallel with the bar x^2 , working in the same slot. Of course, the greater the angle from this line the more rapid will be the variation of the brace Z upon the disk, as the spring bar w^2 is moved up and let down.

The pressure of the paste-roller h^2 upon the labels must be sufficient to apply the paste, but not too great, or, as the upper label is drawn out, it would draw the one beneath it.

This pressure is regulated by the gauge-screw a^2 upon the bar b^2 , which rests upon the spring rod w^2 , a short distance from its connection with the track d .

To prepare this part of the machine for work, after the track is adjusted to the size of the can, the front plate of the label-holder is removed, the brace is raised from the disk s^2 by raising the crank d^1 , when the movable bottom of the label-holder is brought down by reversing the vertical screw-shaft W, as above set forth.

The back plate of the label-holder is brought under and even with the inner edge of the further track, and adjusted vertically by lines upon the end plate, and secured by the set-screw w^1 .

The bottom is adjusted to the proper size, and the

labels are placed upon it evenly against the front plate. The adjustable plate z^1 is then brought against the other end, and the paste-box Y is brought forward until the paste-roller h^2 is in the right position upon the labels.

The front plate is replaced, and the sliding plates g^2 , upon the front and back plates, are slid nearly to the paste-roller, to hold the back end of the labels, and fastened by set-screws. The labels are then moved up by the crank, turning the wheel t^2 until one end is pressed under the clasp y , and the others under the paste-roller h^2 . The whole is then more nicely adjusted laterally by the screw-rods x^1 .

If it should be found, after commencing labeling, that the labels do not come evenly upon the cans where they overlap, the defect can be remedied by varying the back or right-hand end of the label-holder by the screw-rod x^1 .

The reservoirs H, for supplying the varnish, are made cylindrical, and revolve upon the central shaft e^2 . They are filled about half full of varnish, and their caps secured tight.

The labeled can passes between the varnish-brushes f^3 , against the bars g^3 , by which it revolves the reservoirs.

As they revolve, the spring levers h^3 are brought in contact with the wheels i^3 , which spring them in and open little valves in the tubes k^3 , which pass from the reservoirs to the brushes, and admit a supply of varnish, which is distributed over the ends of the cans as they revolve in passing along.

The varnish being in the lower part of the reservoir will only press upon the tubes while the brushes are in contact with the can, so that if there is any leakage, there will be no waste.

The bristles of the varnish-brushes f^3 point diagonally outward from the reservoirs and inward toward the cans,

In this shape the brushes carry the varnish downward and to the can, when they are below the center of the reservoirs when they are in use, and any surplus varnish that may come upon them, backward and inward, and to the cup-like opening of the tubes, where it will remain until again brought around to the cans.

These brushes are made long enough to pass the center of the largest cans, when they will answer for all sizes.

In the full-sized machines there will be a greater proportional space between the reservoirs and brushes. In this space is to be attached to the sides of the tubes a small spring pad, cornered out to fit upon the corners of the cans.

One side of this is long and flaring, and serves to guide to and then gauge the narrow flange upon the outer rim or raised corner of the can.

This pad varnishes neatly the raised rim of the can which is not covered by the label, and also prevents any bristles of the varnish-brushes from getting upon the face of the labels.

To the same end the bristles are made to stand back considerably from a line with the brushes, so that their points will not come in contact with the can first.

The supply of varnish is regulated by the gauge-screws m^2 at the ends of the spring bars n^2 , which support the regulating wheels i^1 .

As more or less varnish is wanted these wheels are carried in or out by these screws; when in, they open the valves more and keep them open longer, and, of course, admit a greater supply of varnish.

This may be further regulated by varying the bars n^2 up or down by the slot in the ends through which the gauge-screws m^2 pass, thus bringing the wheels i^1 nearer to or further from the ends of the spring

levers h^3 , and will keep the valves open a longer or shorter time.

The reservoirs H are adjusted to the length of the can by loosening a set-screw and turning one of the reservoirs upon its central screw-shaft e^1 , to the desired point, where it is again fastened.

In adjusting this, the brushes must be placed opposite those upon the stationary reservoir upon the opposite end of the shaft.

The regulating wheel is adjusted to this adjustable reservoir when set by the long gauge-screw p^1 .

As there is only a difference of one inch in the length of all the cans for which this machine is designed, this adjustment will occupy but a short time.

From the varnishing-reservoirs the can passes to the varnish-smoother. This is a double set of brushes I, which revolve around a common center and upon their own centers.

As the can passes between a pair of them, it strikes the bars r^2 , and, carrying the brushes along, brings the pinions s^2 into the racks t^2 , which revolve them rapidly in a direction opposite to that in which the can revolves, thereby smoothing nicely and evenly the varnish upon it.

To prevent cross-lines being made upon the varnish as the cans pass from the brushes, they are opened out, being upon spring arms, clear of the ends of the can by the oblique bars v^2 .

The brushes are let back to their position easily and without snap, by oppositely oblique opposite ends of the same bars.

These brushes, like the reservoirs H, are adjusted to the length of the can by turning them upon the screw-shaft w^2 , and fastening them by set-screws, care being taken to place the brushes opposite each other.

The rack t^2 , and oblique bar v^2 , are adjusted by the screw-rod x^2 and guide-bar y^2 .

From these revolving brushes the can passes onto the track z^2 , which is inclined so as to throw the bottom of the varnished can against the guide-bar a^1 . This prevents the top from being marred.

Packers are not particular about the bottom, which, standing upon shelves, is not seen, but like to have the top present a clean, nice surface.

The fan b^1 upon the end of the shaft of the small wheel b is to prevent too rapid motion of the machine, and consequent sudden action and jarring of the parts.

The fans are set upon the curved spring arms, which are thrown out as the speed is increased, and thereby offer more resistance.

The operation of the machine is briefly as follows:

The cans are placed in the feed-box O, and, passing through the adjustable opening in the bottom, drop between the spring guides K upon the way or track d , and are admitted at regular intervals to the main wheel D by the revolving wheels a operated by the eccentric friction-wheel B, revolving upon the periphery of the large wheel D.

The weight of the cans moves the wheel, supposing it has been first started by hand.

As the can approaches the label-holder V, it comes in contact with the paste-pad x at a point on the can that will come down on the end of the labels. Almost simultaneously with touching this pad it touches the arm a^1 , which, operating through the rack and pinion R d^1 , and shaft e^1 , brings the pad out of the way of the can and against the paste-wheel S, where it is re-pasted for the next can, and is retained in this position by the catch k^1 .

As the can passes along it liberates the clasp y , held by the spring catch n^1 upon the end of the labels.

The pasted can, adhering to the upper label, carries it along and holds by its pressure the under ones

in their place, until the clasp *y*, having followed the can up a sufficient distance to allow the label on which it rested to pass, liberates the pad *x* from the catch *k*¹, which, as it is brought back to its place by the spring *h*¹, carries the clasp *y* onto the end of the labels, where it is secured by the spring catch *n*¹.

The can being carried along by the wheel, the weight of the cans following moving it, the label is drawn from under the paste-roller *h*² at the other end of the labels, and, by the band *P*, pressed evenly and smoothly upon the can.

The labeled can, passing from the band *P*, strikes the arm *n*², which operates the device for supplying the labels. Simultaneously with this it passes between the brushes of the revolving varnishing-reservoirs *H*, and is varnished as heretofore described.

The construction of my machine is such that all its operations are performed by the weight and consequent force of the cans, thereby saving great expense for motive-power.

If desired, however, the machine may be run by hand or other power.

The brushes in this machine are all to be made so as to be taken off and cleaned when not in-use, or replaced when worn out.

The elevated track *s*¹ is also to be made adjustable, so that the center of the cans, of whatever size, may be brought to correspond with the center of the revolving brushes *I*.

By the arched part of the track over the label-holder room is secured for the paste-roller, and the can has to travel, while the label is being laid on, a greater distance than the length of the label, thereby keeping it taut, and laying it on evenly and smoothly.

Having thus fully described my invention,

What I claim as new, and desire to secure by Letters Patent, is—

1. The rebated bars *d d*, constructed as described, with arched part forming the adjustable track and guides, substantially as and for the purposes herein set forth.

2. The independently-adjustable spring guides *K*, constructed and arranged substantially as and for the purposes herein set forth.

3. The wheel *D*, provided around its periphery with an elastic covering, *v*, substantially as and for the purposes herein set forth.

4. In combination with the elastic wheel *D*, the elastic belt *P* and weighted spring wheel *G*, arranged and operating substantially as and for the purposes herein set forth.

5. The cluster of wheels *a a*, each revolving around its own center, and all around a common center, substantially as and for the purposes herein set forth.

6. The eccentric wheel *E*, revolving upon the periphery of the elastic wheel *D*, in combination with the cluster of wheels *a a*, substantially as and for the purposes herein set forth.

7. The feed-box *O*, constructed as described, with slide *s* and set-screw *z*, substantially as and for the purposes herein set forth.

8. In a machine for labeling cans, applying the paste to the can, for the purpose of picking up and carrying along the label, substantially as herein set forth.

9. The paste-pad *x*, arm *z*, swivel-bar or shaft *g*¹, and crank *f*¹, on the shaft *e*¹, all constructed and arranged to operate substantially in the manner and for the purposes herein set forth.

10. The arrangement of the shaft *b*¹ with arms *a*¹, spring *h*¹, rack *R*, and pinion *d*¹, for operating the paste-pad *x*, substantially as herein set forth.

11. The clasp *y*, constructed as described, and held by the spring catch *n*¹ or other suitable device, substantially as and for the purposes herein set forth.

12. The spring catch *k*¹, operating in combination

with the arm *m*¹, on the shaft *e*¹, substantially as and for the purposes herein set forth.

13. The bar *o*¹, carrying the clasp *y*, and provided with the point *r*¹ and arms *s*¹, and forced upward by the spring *p*¹, all substantially as and for the purposes herein set forth.

14. The adjustable label-holder *V*, constructed as described, and provided with adjustable guide-plates *g*², substantially as and for the purposes herein set forth.

15. The movable end plate *z*¹, adjusted by means of the set-screw *a*², and provided with springs *b*², substantially as and for the purposes herein set forth.

16. The movable adjustable bottom *d*², formed of two plates dovetailed into each other, and adjusted by the set-screw *e*², working in an oblique slot, substantially as and for the purposes herein set forth.

17. The arrangement of the adjustable bottom *d*² upon the arms *f*², working on the upright screw-shaft *w*, substantially as and for the purposes herein set forth.

18. The combination and arrangement of the arm *n*², shaft *m*², lever *r*², brace *Z*, and grooved disk *s*² on the upright screw-shaft *W*, for supplying the labels, substantially as herein set forth.

19. In combination with the mechanism for supplying the labels, as herein set forth, the wheel *t*² and pinion *v*², for reversing the motion, substantially as herein set forth.

20. The combination and arrangement of the spring bar *w*², adjustable guide-bar *z*², and lever *x*², connected with the brace *Z*, for the purpose of regulating the supply of labels, substantially as herein set forth.

21. In combination with the spring rod or bar *w*², the set-screw *a*² and bar *b*², for regulating the pressure of the paste-roller *h*² on the labels, substantially as herein set forth.

22. The combination of the paste-rollers *X* and *h*², intermediate roller *i*², and adjustable paste-box *Y*, all constructed and operating substantially as and for the purposes herein set forth.

23. The arrangement upon the end of the swivel-rod *g*¹ of the arm *t*², working in the ratchet-wheel *v*², for turning the paste-roller *S*, substantially as herein set forth.

24. The arrangement of the screw-rods *o* with cranks *f*², for varying the distance between the tracks, substantially as herein set forth.

25. The arrangement of the rods *g g* and set-screws *h*, for securing the adjustable track-bar in any position desired, substantially as herein set forth.

26. The sliding bar *M*, provided with unequal inclines *p*, and operated by means of the screw-wheel *L*, for the purpose of varying the distance of the track from the main wheel, reservoirs, and brushes, substantially as herein set forth.

27. In combination with the unequal inclines or wedges *p* on the sliding bar *M*, the set-rod *n*, passing through the oblique slots *o*, for adjusting the curvature of the track to cans of different diameter, substantially as herein set forth.

28. The varnish-reservoirs *H*, constructed as described, and arranged on the shaft *e*², one being stationary and the other adjustable on said shaft, substantially as and for the purposes herein set forth.

29. The tubes *k*², extending from the reservoirs *H*, and provided with small valves, operated by the spring levers *h*², substantially as and for the purposes herein set forth.

30. The varnish-brushes *f*², constructed as described, and attached to the tubes *k*², substantially as and for the purposes herein set forth.

31. The wheels *i*², for operating the spring levers *h*², to open the valves in the tubes *k*², substantially as herein set forth.

32. The arrangement of the spring bars n^2 with the set-screws m^2 and p^2 , for adjusting the wheels i^2 , substantially as and for the purposes herein set forth.

33. The adjustable brushes I, all revolving around a common center, and each around its own center, substantially as and for the purposes herein set forth.

34. The arrangement of rack t^2 and pinions s^2 , for revolving the brushes I, each around its own center, substantially as herein set forth.

35. The inclined bars v^2 , for opening the brushes I, carrying them outward from the can, substantially as and for the purposes herein set forth.

36. The spring bands r r , arranged as described, between the reservoirs H and between the brushes I, substantially as and for the purposes herein set forth.

37. The inclined track z^2 , arranged substantially as described, and for the purposes set forth.

38. The combination of the inclined track z^2 and guide-bar a^2 , substantially as and for the purposes herein set forth.

39. The regulating-fan b^2 , arranged substantially as described, and for the purposes herein set forth.

40. A machine for labeling and varnishing fruit-cans, when it is operated in all its parts by the weight of the cans, substantially as herein set forth.

In testimony that I claim the foregoing, I have hereunto set my hand this 20th day of May, 1870.

Witnesses:

E. M. COLVER,

D. S. WORTHINGTON.

ALFRED C. PLATT.