

(No Model.)

2 Sheets—Sheet 1.

G. R. MCGINNIS.
CHECK ROW CORN PLANTER.

No. 522,381.

Patented July 3, 1894.

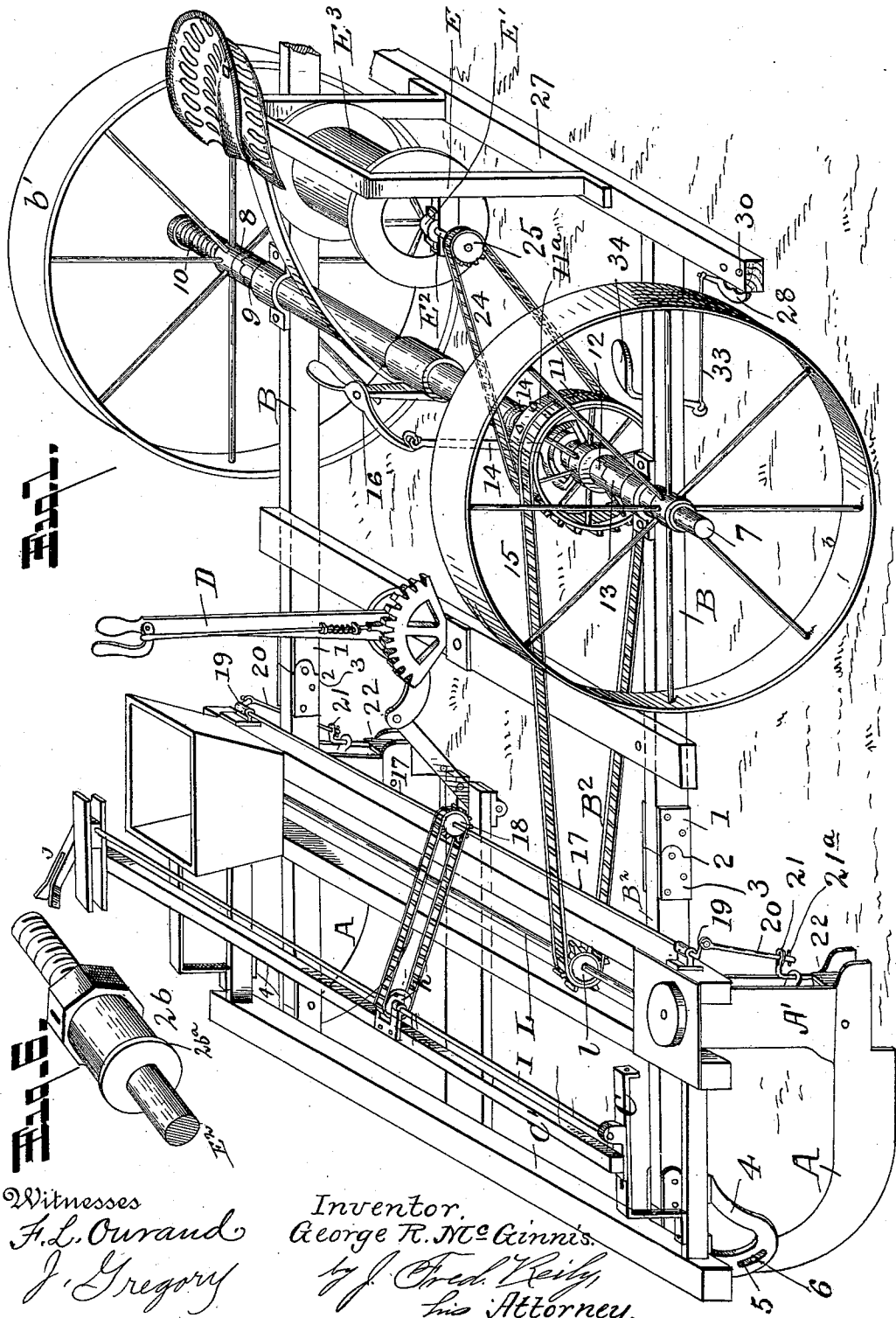

Witnesses
A. L. Ovrand
J. Gregory

Inventor,
George R. McGinnis.
by J. Fred. Keily
his Attorney.

(No Model.)

2 Sheets—Sheet 2.

G. R. MCGINNIS.
CHECK ROW CORN PLANTER.

No. 522,381.

Patented July 3, 1894.

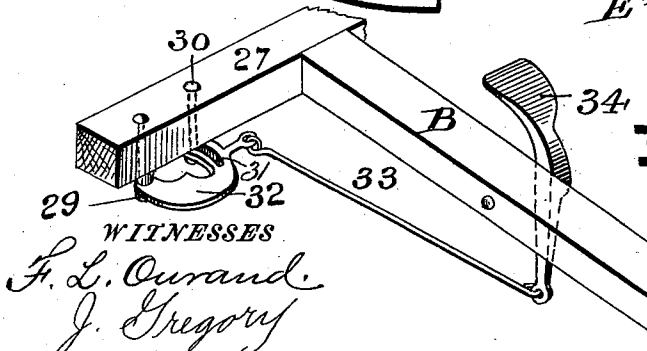
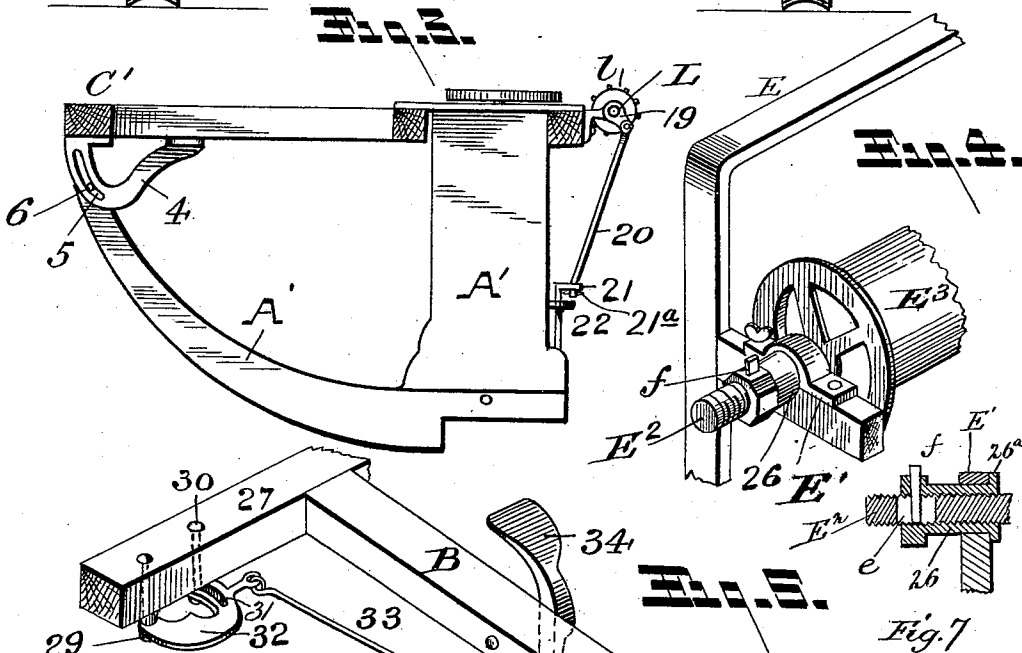
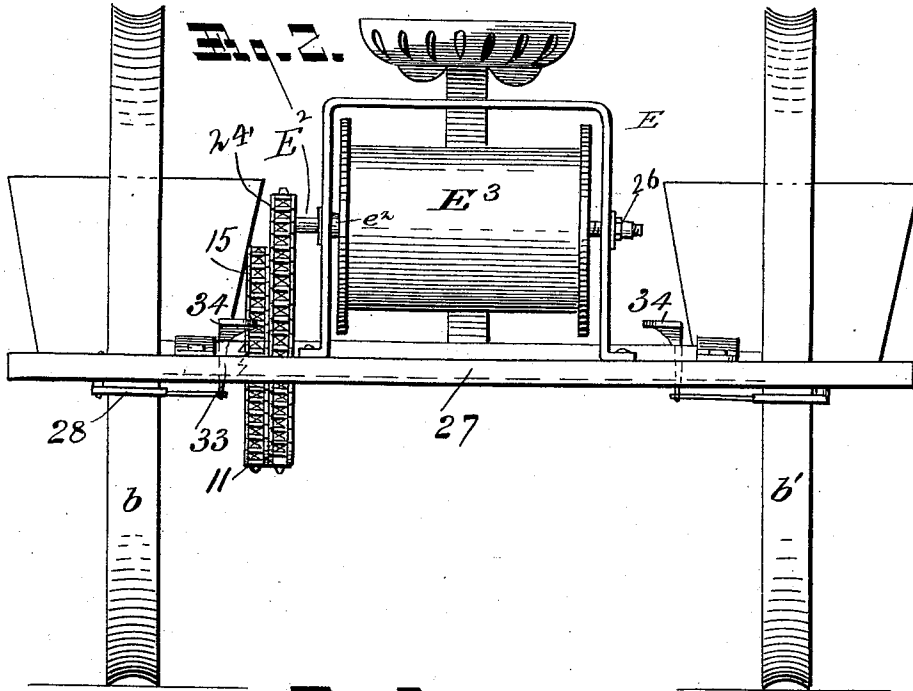

WITNESSES
F. L. Ouraud.
J. Gregory

INVENTOR:
George R. McGinnis.
 by *J. Fred Kelly,*
 his Attorney.

UNITED STATES PATENT OFFICE.

GEORGE R. MCGINNIS, OF CISCO, ASSIGNOR TO FRANK WILLIAMS AND
THOMAS B. WILLIAMS, OF MONTICELLO, ILLINOIS.

CHECK-ROW CORN-PLANTER.

SPECIFICATION forming part of Letters Patent No. 522,381, dated July 3, 1894.

Application filed March 18, 1893. Serial No. 466,689. (No model.)

To all whom it may concern:

Be it known that I, GEORGE R. MCGINNIS, a citizen of the United States, residing at Cisco, in the county of Piatt and State of Illinois, have invented certain new and useful Improvements in Check-Row Corn-Planters; and I do declare the following to be a full, clear, and exact description of the invention, such as will enable others skilled in the art to which it appertains to make and use the same, reference being had to the accompanying drawings, and to the letters and figures of reference marked thereon, which form a part of this specification.

My invention consists in certain new and valuable improvements on the corn planter for which Letters Patent No. 426,947 were granted to me April 29, 1890; and my invention will be hereinafter fully described and claimed.

Referring to the accompanying drawings, Figure 1 is a perspective view of my improved corn planter. Fig. 2 is a rear elevation thereof. Fig. 3 is a side elevation of the front half of the planter. Figs. 4, 5, 6 and 7 are detail views, which will be hereinafter described.

The same letters and numerals of reference indicate corresponding parts in all the figures.

In the drawings, B indicates the rear or wheel frame, upon the rear part of which the driver's seat is mounted. The forwardly-projecting side-beams of this frame are formed in two sections or parts, B' and B², and to their forward ends the front cross-beam C' of the runner frame C is hinged, as shown, to enable the said frame, which carries the seed-boxes and seed-dropping mechanism, to be raised and lowered by the lever D, to elevate or depress the heels of the runners, and thus regulate the depth of the furrows opened by the runners.

The connected ends of the side-beams B', B², are hinged together by the hinges 1; the rear section of these hinges being formed with the lower square projection 2, adapted to lock against a square shoulder 3 on the under part of the front hinge-section. It will be seen that by this peculiar construction while the runner frame C is free to move on its front hinges, that when the lever D is drawn back to

raise the runner frame the shoulders 3 will lock against the parts 2 and the beams will be held straight and rigid, thus facilitating the raising of the rear end of the hinged front frame by the lever D; while the weight of the driver can thus be utilized, owing to this rigid interlocking of the beams, to take the weight off the front of the planter and the horses' necks, while turning around at the end of a row, and in going from one field to another.

4, 4, indicate curved metal castings, one of which is bolted beneath the front end of the front or runner frame C at each side thereof. These metal castings are each formed at the point shown with a curved slot, 5; and the front end of the runner A is secured to the casting by a bolt, 6, passing through the said end and the curved slot of the casting. It will be seen that by using this casting the runner need not be of just such a length to be fitted on, as the curved slotted casting will enable runners of slightly different lengths to be employed, which is a decided practical advantage.

7 indicates the axle, which revolves with one of the covering-wheels, b, fixed upon it, while the other covering-wheel, b', fits loosely upon the axle and has a clutch-section, 8, on the inner end of its hub, and is normally pressed into engagement with a fixed clutch-section, 9, secured to the revolving axle, by the pressure of the spring 10, which is mounted on the outer end of the axle as shown, to facilitate the turning of the planter at the end of a row.

11 indicates a sprocket-wheel which is mounted loosely on the left-hand part of the axle, as shown, carrying a clutch-section, 12, which is adapted to engage with a fixed clutch-section 13 on the axle, being normally pressed into engagement therewith by a spiral spring, 14. A sprocket-chain, 15, passes around this wheel, 11, and the sprocket pinion l on the shaft L; and this shaft L is thus revolved, and the seed dropped from the seed-boxes down into the seed-spouts by the mechanism which was described in detail in my Patent No. 426,947 before referred to, and which it is therefore not necessary to here describe in detail.

16 indicates the pivoted foot-lever, which en-

gages with the collar of the clutch-sleeve of sprocket-wheel 11 as shown, whereby the sprocket-wheel can be thrown out of gear, when turning around at the end of a row, or
5 when driving from field to field.

17 indicates the second dropper shaft, which is mounted in bearings at the rear end of the runner frame C, and has a sprocket-pinion, 18, keyed upon it, around which passes the sprocket-chain from the sprocket-wheel *k* of the shaft I; this shaft being operated by the check-row cord as described in detail in my above-specified patent, No. 426,947. The outer ends of the drop-shaft 17 are provided
15 with small crank-arms, 19, 19, to which are pivoted the upper ends of lever-rods 20, 20. The lower ends of these rods pass through the slotted, outwardly-bent, upper ends, 21, of the stems of small sliding doors, or valves, 20
22, which are arranged as shown in bearings to control the openings at the lower ends of the seed-spouts A'. The lower extremities of the rods 20 are provided with keys, 21^a, to prevent their pulling out of the slotted ends 21.
25 It will now be seen, that as the shaft I is turned by the check-row cord as the planter is driven forward, that the drop-shaft 17 will be turned, and through its cranked end-arms and lever-rods 20 will move the slide-doors 22
30 up and down at each stroke of the pawl-lever J, as the latter is actuated by the successive buttons on the check row cord which passes through its forked end in the usual manner, thus dropping the seed into the furrow at the
35 exact points desired.

It will be seen that by my invention the feed of the corn or seed from the seed-boxes down into the seed-spouts is effected by one set of mechanism, while the discharge of the
40 seed from the lower ends of the spouts into the furrows is controlled by an entirely separate mechanism.

The rim of the sprocket-wheel 11 is of such width that a double series of cogs or teeth, 11^a, are formed upon it, one of which is engaged by the sprocket-chain 15, which runs to the pinion on the shaft L, while a second sprocket-chain, 24, passes around the other series of teeth of wheel 11 and thence around
50 a pinion 25 secured on the drum-shaft, E². This shaft is mounted and turns in bearings, E', on the seat arch or frame E, below the driver's seat, as shown; and upon it is loosely mounted the drum, E³, upon which the check-row cord is wound. The left-hand end of this
55 drum bears against a small fixed collar *e*² on the shaft E², while at its other end the shaft is threaded, and a tension-sleeve, 26, is adjustably mounted thereon; this sleeve being
60 internally threaded, having a round body which passes through the bearing E' so as to revolve with the shaft, while its inner end 26^a is flanged to bear against that end of the drum, and its outer end is squared to adapt
65 it to be turned by a wrench. It will thus be seen that when this tension-sleeve is moved in, by applying a wrench to its outer end,

the drum will revolve with the shaft E²; or the friction may be so adjusted that the drum will only turn
70 when a certain amount of power is applied to the periphery thereof. The threaded part of the shaft is provided with a longitudinal slot *e*, and the tension-sleeve has an opening
75 through which a key, *f*, is passed, running through the slot of the shaft, to hold the sleeve from turning on the shaft after it has been screwed up to the desired point.

The rear cross-beam, 27, of the wheel frame B has its ends extended, and to these extended
80 ends, directly back of and in line with the covering wheels *b*, *b'*, are movably secured the scrapers, 28, 28. The scrapers are pivoted near one end, at, 29, to the extended ends of bar 27, with a headed bolt, 30, passing through
85 slots, 31, in their inner rear ends, as shown in Fig. 5, and are formed with the curved or rounded forward parts 32. Connecting rods, 33, connect the inner ends of the scrapers pivotally with the lower ends of foot-levers 34,
90 which are centrally pivoted as shown within easy reach of the driver's feet. It will now be seen that by pressing down the upper ends of the foot levers, the pivoted, slotted, scrapers will be swung forward so that their curved
95 forward part will scrape the dirt away which accumulates in the concaved covering-wheels; and by raising the curved upper ends of said foot-levers with the toe after they have been
100 thus depressed the scrapers are slid back out of the way; and can thus be used as frequently as required.

Having thus described my invention, what I claim, and desire to secure by Letters Patent, is—
105

1. In a check-row corn-planter, the combination, with the supporting frame, of the seed
110 hoppers provided with devices for dropping the seed into the seed spouts, the shaft 17, geared to the sprocket-wheel of the front shaft I and having the small crank-arms at its ends, the vertically reciprocating valves controlling the openings at the lower ends of the seed-spouts, and connections between said valves and the crank-arms of the shaft 17; substantially as set forth.
115

2. In a corn-planter, the combination, with the supporting frame, the seed spouts and the runners, of the curved slotted castings 4, and the securing bolts passing through the forward
120 ends of said runners and the curved slotted castings; substantially as set forth.

3. In a check-row corn-planter, the combination, with the supporting frames, of the axle having the fixed covering wheel and the fixed clutch section 13, the loose sprocket-wheel having the clutch-section 12 adapted to engage with the fixed section 13, the coiled spring bearing against the loose sprocket-wheel and the foot-lever adapted to throw
130 said wheel out of gear, the shaft L operating the seed-dropping mechanism at the bottom of the hopper, and geared with the sprocket-wheel on the axle, the valves controlling the

openings at the lower ends of the seed-spouts, and the shaft 17, having the crank-arms connected with said valves and geared with the forward shaft which is operated by the check-row cord; substantially as set forth.

4. In a corn-planter, the combination with the covering-wheels of the movable scrapers having the curved forward part, pivoted near one end, formed at the other end with a slot through which a headed bolt passes, the pivoted foot-levers, and connections between said levers and the pivoted bodies of said scrapers; substantially as set forth.

5. In a check-row corn-planter, the device for winding up the check-row cord consisting of the shaft, mounted in raised bearings, having the fixed collar, and geared to the revol-

ing axle, said shaft having the threaded part formed with the longitudinal slot, a drum loosely mounted on the central part of the shaft, and the internally-threaded tension sleeve, having the round body passing through and adapted to revolve in one of the bearings E', and formed with the flanged inner end, the squared outer end, and with the transverse opening, and the key adapted to pass through said opening and the slot of the shaft; substantially as set forth.

In testimony whereof I affix my signature in presence of two witnesses.

GEORGE R. MCGINNIS.

Witnesses:

FRANK WILLIAMS,
WILL MCGINNIS.