

W. J. TRIMBLE.
CAR-COUPLING.

No. 192,544.

Patented June 26, 1877.

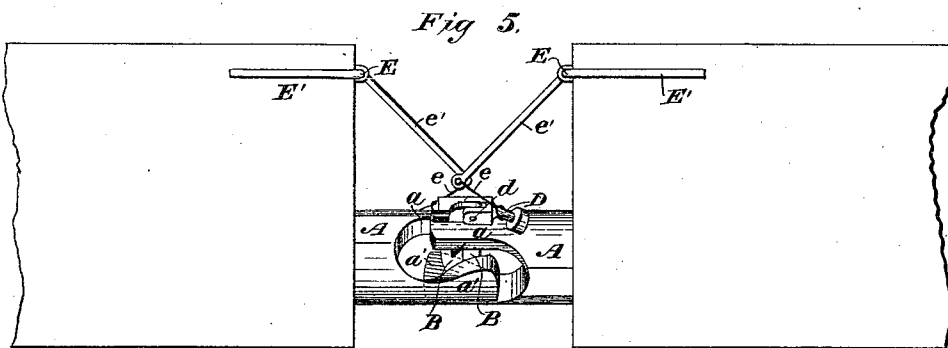
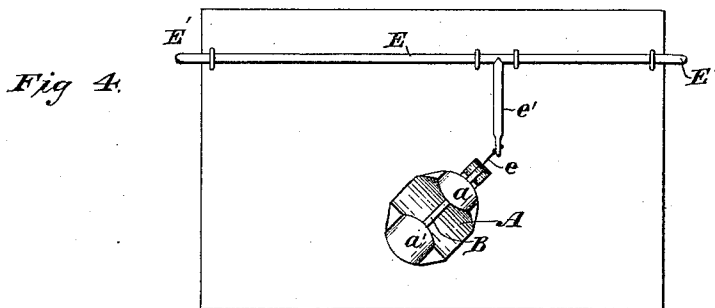
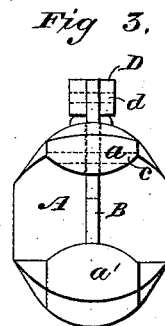
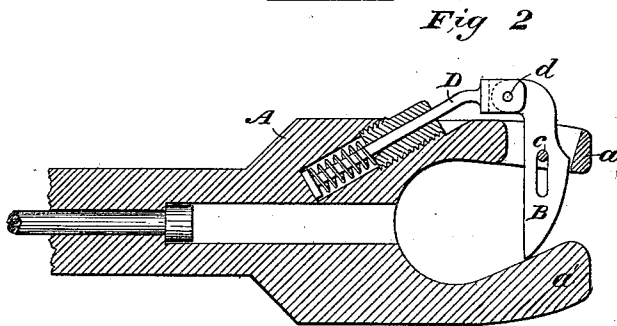
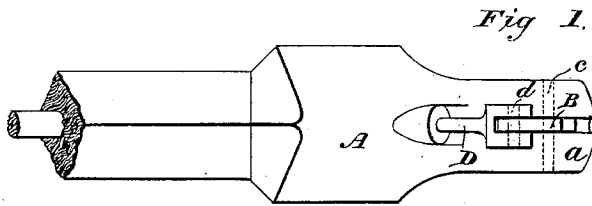

WITNESSES

Wm. A. Shindle
J. Stieh

INVENTOR

W. J. Trimble.

By *his* Attorneys

Baldwin, Hopkins & Layton.

UNITED STATES PATENT OFFICE

WILLIAM J. TRIMBLE, OF TOLEDO, OHIO.

IMPROVEMENT IN CAR-COUPPLINGS.

Specification forming part of Letters Patent No. 152,544, dated June 26, 1877; application filed March 2, 1877.

To all whom it may concern:

Be it known that I, WILLIAM J. TRIMBLE, of Toledo, in the county of Lucas and State of Ohio, have invented certain new and useful Improvements in Car-Couplings, of which the following is a specification:

My invention more especially relates to car-couplings of the class which automatically engage as they abut.

The principal object of my invention is to enable me to use couplings, all alike, at each end of the cars, and yet be enabled, automatically, to couple any two cars together, no matter which ends may abut. To this end my improvement consists in a draw-head, having a projecting horn or tongue on one side of both a vertical and a horizontal axial plane passing through said draw-head, and provided with a transverse slot inclining inwardly across the axis of the coupling at an angle of about forty-five degrees, for the reception of the coupling-pin, by which means, when two draw-heads abut with their coupling-pins at right angles to each other, one horn or pin slides past and overlaps the other, and their coupling-pins interlock crosswise of each other without difficulty, it being only necessary to do this that the coupling-pins at opposite ends of the car should be inclined in opposite directions.

The object of the next part of my invention is to support the coupling-pins firmly, and to aid in guiding the horns of the draw-head in their proper position; to which end my improvement consists in constructing the draw-head with a secondary horn or tongue arranged diagonally opposite to the other one, or on the opposite sides of both, a vertical and horizontal plane passing through the axis of the draw-head, these horns being of a size smaller than the body of the draw-head, so as to permit them readily to pass each other, to allow sufficient play to compensate the swaying of the cars, and to allow the ends of the horns to abut against the solid part of the draw-head without strain on the coupling-pins when the cars are pressed together.

My improvement further consists in combining, with a diagonally-arranged horn and its inclined slot, an endwise-moving pivoted spring

coupling-pin, whereby the coupling is automatically effected.

My improvement further consists in arranging couplings, constructed as above set forth, on opposing ends of the cars at angles of opposite inclinations, so that as the cars abut the horns of one coupling will enter the jaws of the other, no matter which end of the car comes foremost, without interference.

My improvements further consist in a draw-head constructed with a projecting horn above and on one side of its axis, a slot therein sloping inward and downward at an angle of about forty-five degrees, a slotted coupling-pin working and guided in said slot, and pivoted to a spring-arm moving endwise in a socket in the draw-head, whereby the coupling-pin is always held in its locked position.

The object of the next part of my invention is to enable the train-hands to detach the coupling without going between the cars; to which end my improvement consists in combining with a draw-head a coupling-pin inclined at an angle of forty-five degrees, and a crank-lever connected with the coupling-pin by a flexible link to permit of the withdrawal of the coupling-pin.

In the accompanying drawings, which show so much of my improved coupling as is necessary to illustrate the invention herein claimed, Figure 1 is a plan view of one of the draw-heads taken at an angle of forty-five degrees from the perpendicular. Fig. 2 is a vertical longitudinal section therethrough, at a similar inclination; and Fig. 3 is an end view of the draw-head, the coupling-pin being shown as if arranged vertically instead of being inclined, its true inclination being that shown in Figs. 4 and 5, of which one is a front elevation and the other a side view, showing two draw-heads coupled together.

In order to carry out the first part of my invention I construct a draw-head, A, with a horn or tongue, *a*, arranged above and to one side of the axis of the draw-head, and with a slot therein inclining downward and inward at an angle of about forty-five degrees. A coupling-pin, B, works freely endwise through this slot, and also has free rocking motion therein, being held in place by means of a longi-

tudinal guide-slot and a pin, *c*. The upper end of the coupling-pin is connected by a pivot, *d*, with a spring-rod, *D*, movable endwise in a socket in the draw-head, as clearly shown in Fig. 2. The special mode of construction of the draw-head and spring-rod is not, however, essential to the first part of my invention, as other well-known equivalent devices may be used, the essential feature of this part of the invention being the incline or diagonal arrangement of the coupling-pin.

The lower end of the coupling-pin is made curved, beveled, or inclined on its outer side, so as readily to permit the entrance of the coupling-pin or link of the opposing draw-head, this pin extending across the axial line of the draw-head.

It will be obvious that this device would serve a good purpose, were the draw-head provided with but a single horn; but in order to carry out the second part of my invention, I provide another horn or tongue, *a'*, arranged in the same diagonal plane as the coupling-pin, and which may be slotted or recessed for the reception of said pin or not, as desired.

The points of the horns, it will be observed, are made smaller than the body of the draw-head, as shown in Fig. 5, and the heads are recessed so as to form a circular cavity, as shown in Figs. 2 and 5. Owing to this construction, the two abutting draw-heads readily interlock with each other, the tips of their horns abutting against the body of the draw-head when the cars are pressed together, and yet compensating the lateral swaying of the cars.

The opposing draw-heads, it will be noticed, are so arranged that their coupling-pins lie at right angles to each other, and the draw-heads at the opposite ends of each car are also arranged with their coupling-pins at right angles to each other, consequently either end of any two cars may be coupled together.

In order to enable the train-hands to uncouple the cars without going between them, each coupling-pin is connected by a chain or flexible link, *e*, with a crank, *e'*, of its respective rock-shaft *E*, mounted in suitable position upon the car, and actuated by a foot or hand lever, *E'*, Fig. 5. When released by the train-hand or brakeman the coupling is at once restored to its normal position by a spring. This flexible link-connection between the crank and coupling-pin is essential, as one works in a vertical and the other in an inclined plane, consequently some compensation for their difference in angular movement must be provided.

The operation of my improved coupling will readily be understood from the foregoing description, and its advantages will be obvious to all practical railroad men.

It is unnecessary to describe the details of construction of the other portions of the draw-head, as they are well known, and constitute no part of the subject-matter herein claimed.

I do not broadly claim automatically coupling cars together, or uncoupling them without going between the cars, as various devices for attaining these objects are well known; neither do I claim a draw-head having a horn or tongue arranged on one side of a vertical plane passing through the axis of the draw-head and in the same horizontal plane as said axis, nor the combination of two such draw-heads and spring coupling-pins moving parallel with, and sliding lengthwise of, each other, and they form no part of my invention.

I claim as my invention—

1. The draw-head constructed substantially as hereinbefore set forth, with a horn on one side of both a vertical and horizontal plane passing through the axis of the draw-head, said horn being provided with a slot inclining downward and upward at an angle of forty-five degrees, for the reception of the coupling-pin, as set forth.

2. The draw-head constructed as described, with two horns arranged on opposite sides of both a vertical and horizontal plane passing through the axis of the draw-head, with a slot through at least one of the horns, inclined at an angle of forty-five degrees, for the purposes specified.

3. The combination, substantially as hereinbefore set forth, of the draw-head, its diagonally-arranged horn, inclined slot, and a spring-pin moving endwise through one of the horns, for the purposes set forth.

4. The car-coupling hereinbefore described, consisting of the combination of two draw-heads having their coupling-pins arranged at an angle of forty-five degrees, and inclined in directions opposite to each other, whereby their uninterrupted coupling is secured.

5. The draw-head hereinbefore described, consisting of the horn arranged above and on one side of the axis of the draw-head, a slot therethrough inclined inwardly and downwardly at an angle of forty-five degrees, the coupling-pin moving endwise through said slot, and the spring-arm jointed to the coupling-pin.

6. The combination, substantially as hereinbefore set forth, of the draw-head, its diagonally-arranged horns, the inclined slot therein, the spring coupling-pin, the crank-lever, and the link-connection between the crank-arm and spring-pin, whereby the coupling-pin is retracted.

In testimony whereof I have hereunto subscribed my name.

W. J. TRIMBLE.

Witnesses:

WM. J. PEYTON,
E. C. DAVIDSON.