

(19) **DANMARK**



Patent- og  
Varemærkestyrelsen

(10) **DK/EP 2806780 T3**

(12) **Oversættelse af  
europæisk patentskrift**

- 
- (51) Int.Cl.: **A 47 L 11/40 (2006.01)** **A 47 L 9/28 (2006.01)**
- (45) Oversættelsen bekendtgjort den: **2016-03-21**
- (80) Dato for Den Europæiske Patentmyndigheds bekendtgørelse om meddelelse af patentet: **2016-01-20**
- (86) Europæisk ansøgning nr.: **13710067.3**
- (86) Europæisk indleveringsdag: **2013-01-24**
- (87) Den europæiske ansøgnings publiceringsdag: **2014-12-03**
- (86) International ansøgning nr.: **IT2013000021**
- (87) Internationalt publikationsnr.: **WO2013111170**
- (30) Prioritet: **2012-01-27 IT VI20120025**
- (84) Designerede stater: **AL AT BE BG CH CY CZ DE DK EE ES FI FR GB GR HR HU IE IS IT LI LT LU LV MC MK MT NL NO PL PT RO RS SE SI SK SM TR**
- (73) Patenthaver: **ALI S.p.A.-div. DIHR, Via Camperio, 9, 20123 Milano, Italien**
- (72) Opfinder: **SPINETTI, Alberto, DIHR ALI S.p.A., Via Camperio 9, I-20123 Milano, Italien**  
**PASQUALOTTO, Stefano, DIHR ALI S.p.A., Via Camperio 9, I-20123 Milano, Italien**  
**DALLAN, Giancarlo, DIHR ALI S.p.A., Via Camperio 9, I-20123 Milano, Italien**  
**RONCATO, Luca, DIHR ALI S.p.A., Via Camperio 9, I-20123 Milano, Italien**
- (74) Fuldmægtig i Danmark: **Plougmann Vingtoft A/S, Rued Langgaards Vej 8, 2300 København S, Danmark**
- (54) Benævnelse: **Ergonomisk professionel opvaskemaskine**
- (56) Fremdragne publikationer:  
**EP-A1- 1 586 265**  
**EP-A2- 1 029 499**  
**CH-A- 398 906**  
**DE-A1- 2 442 619**  
**DE-A1- 3 911 305**  
**FR-A- 1 287 104**  
**FR-A1- 2 504 381**  
**US-A- 2 575 493**  
**US-A1- 2005 039 777**



## **DESCRIPTION**

**[0001]** The present invention relates to an industrial and/or ergonomic professional dishwasher, multi-plane or multi-level type, to be used in public places where used for the preparation and/or consumption of foods and beverages such as restaurants, hotels, canteens, bar, nursing homes, retirement homes, hospitals, etc.

**[0002]** More particularly, the invention relates to an ergonomic professional dishwasher, which presents also reduced energy, water and detergent consumption, as compared to the known types of commercial dishwashers.

**[0003]** As known, dishwashers are hydraulic machines used to wash and often dry dishes, pots, pans and other kitchen utensils, usually domestic and relatively of small size, the use of which is also absolutely essential even at a professional level, i.e. in restaurants, hotels, bars, canteens, nursing homes and/or nursing, hospitals, etc.

**[0004]** Various models of household dishwashers are still known, such as built-in dishwasher and/or "undercounter" dishwasher, as well as models of professional dishwashers, generally using one or more washing nozzles, disposed inside a wash chamber or compartment and connected to suitable pumps for the supply of the water taken from the waterworks, one or more baskets or shelves to support the tools to be washed, which can be stationary, rotating or sliding, and one or more removable trays to contain detergents, rinses and/or other cleaning solutions and/or disinfectants.

**[0005]** Industrial or professional dishwashers of known type have certain drawbacks, first of all the considerable consumption of water, energy and detergent; just think that a professional dishwasher uses for each wash cycle (i.e. for each stage of soaking, pre-washing, washing, pre-rinsing, rinsing and/or disinfection), a load of water in the tank equal to 50 liters and the quantity of water changes at the discretion of the user. It implies, consequently, considerable significant energy and operating costs.

**[0006]** The document EP 1 586 265 A1 discloses a professional dishwasher according to the preamble of claim 1.

**[0007]** In addition, the professional dishwashers of known type usually provide a zone of soaking of the dishes consisting in practice in a supporting table of dirty dishes, which is positioned outside the wash chamber and which is attached to a bathtub and a shower head used for pre-washing dishes and glasses.

**[0008]** This prerogative implies a significant reduction of useful space, considerable bulks, additional consumption of water and not negligible labor costs dealing with this pre-wash activities.

**[0009]** The object of the present invention is therefore to overcome the above mentioned drawbacks of the prior art and, in particular, primary purpose of the invention is to provide an ergonomic professional dishwasher, which allows to wash, with low consumption of energy, water and detergents, a wide range of dishes, with the further possibility to perform the storage of the same washload items directly into the wash chamber of the machine (typical of domestic dishwashers).

**[0010]** Another object of this invention is to provide an ergonomic professional dishwasher, which allows a reduction of labor costs deriving from hand pre-washing.

**[0011]** Another object of the invention is to provide an ergonomic professional dishwasher, which reduces the overall dimensions inside the environment where it is installed and facilitate, at the same time, the loading of dishes.

**[0012]** Further object of the invention is to provide an ergonomic professional dishwasher, which has a remarkable ability to load the dishes.

**[0013]** Another object of the present invention is to provide an ergonomic professional dishwasher, which also preserves the health and safety of users, since it does not allow to vapors - generated in the storage chamber of the dishes during the wash cycles - to enter into the environment outside.

**[0014]** These and other objects, which will be more clear along the following description, are achieved by an ergonomic professional dishwasher, with low consumption of energy, water and detergent, as claimed in the attached claim 1; other technical characteristics of detail of the invention are indicated in further dependent claims.

**[0015]** In an advantageous manner, the professional dishwasher which is object of the present invention allows to wash, with low consumption of water, energy and detergent, a wide range of dishes, eliminating also the area of soaking and pre-washing of

such dishes (with a considerable reduction of the overall dimensions of the same machine, being no longer required the use of a supporting table for dirty dishes, nor of a bathtub nor of a pre-washing gargoyle).

**[0016]** Furthermore, the elimination of the above pre-washing activities determines the consequent elimination of labor in charge of this type of activity, as well as it further decreases the consumption of water, compared to the prior art, being equal the washing cycles and load of the dishwasher.

**[0017]** The dishwasher according to the invention, which always works with reduced quantities of water in the tank, compared to the commercial dishwashers of known type, allows also to easily load the dishes in the wash chamber, which has a high load capacity, since the dishes can be arranged on multiple levels or shelves variably spaced in height, and determines an excellent washing result, thanks to the prolonged time of action of water and detergent.

**[0018]** Additionally, compared to the prior art, the dishwasher of the invention allows a considerable reduction of energy consumption, due to the lengthened time of the washing cycle and the possibility to use the machine during night hours (when the electricity costs less), and a substantial reduction of the noise level in the outside environment, also because the operation of the machine can be programmed for the night hours, even when there is absence or otherwise reduction of personnel. Finally, the dishwasher object of the present invention allows to eliminate any storage of the clean dish areas, as it can also act as a closet storage of plates, trays, cups and/or various bowls, since it has a chamber or compartment for cleaning which is hermetically sealed, also avoiding the emission in the external environment (the working environment of the user) of the vapors that are created inside the chamber during the washing cycles, and provides to load and discharge automatically the water in the tank, with consequent benefits in terms of cleanliness (hygiene) and of consumption, because the automatic washing cycles are designed in such a way that, at each stage, the consumption of water is the minimum possible, in order to avoid further waste of water, detergent and energy.

**[0019]** It should be further noted that the vapors, which are created inside the wash chamber and which must be disposed of for obvious natural reasons, are not placed in the working environment of the user, but, through a condensation system in a closed circuit, they are condensed and then downloaded; on the other hand, also the vapors that remain in the wash chamber at the end of each cycle is condensed, and this also allows to dry the dishes directly into the chamber, avoiding to use other drying systems, such as heat pumps, definitely more expensive.

**[0020]** The aims and advantages described above, as well as others which will emerge below, will appear more evident from the following description, relating to a preferred exemplary embodiment of the ergonomic professional dishwasher object of the invention, described for indicative and illustrative, but not limitative purposes, with the reference to the accompanying drawings, in which in particular:

- Figure 1 shows a schematic front view of the ergonomic professional dishwasher, according to the present invention;
- Figure 1A shows a side view of a first embodiment of the dishwasher professional ergonomic, according to the invention;
- Figure 1B shows a side view of a further embodiment of the ergonomic professional dishwasher, according to the invention;
- Figure 1C shows a rear view of the ergonomic professional dishwasher shown in Figure 1A, according to the invention;
- Figure 2 shows a top plan view of the ergonomic professional dishwasher referred to Figures 1 and 1B, according to the present invention;
- Figure 3 shows a front view of the ergonomic professional dishwasher, according to the present invention, with the front doors removed and with a more visible wash chamber;
- Figure 4 shows a front view of an embodiment and preferred, but not limiting, of a rotor or nozzle used in ergonomic professional dishwasher, according to the invention;
- Figure 5 shows a top plan view of the rotor or nozzle according to Figure 4, according to the present invention;
- Figure 6 shows a side view of the rotor or nozzle of Figures 4 and 5, according to the present invention;
- Figure 7 shows a partial schematic view of the water accumulation tank placed in the lower compartment of the wash chamber of the ergonomic professional dishwasher, according to the invention;
- Figure 8 shows a schematic view of the hydraulic system used in ergonomic professional dishwasher, according to the invention;
- Figure 9 shows a schematic view of a first embodiment and functioning of the wash pumps used in the hydraulic system according to Figure 8 of the ergonomic professional dishwasher, according to the invention;
- Figure 10 shows a schematic view of a second embodiment and functioning of the wash pumps used in the hydraulic system according to Figure 8 of the ergonomic professional dishwasher, according to the invention;
- Figure 11 shows a schematic view of a third embodiment and functioning of the wash pumps used in the hydraulic system according to Figure 8 of the ergonomic professional dishwasher, according to the invention;
- Figure 12 shows a schematic view of a vapor condensation system employed in ergonomic professional dishwasher,

according to the present invention;

- Figure 13 shows a schematic view of a fourth embodiment and functioning of the wash pumps used in the hydraulic system according to Figure 8 of the ergonomic professional dishwasher, according to the invention;
- Figure 14 shows a schematic view of a fifth embodiment and function of the wash pumps used in the hydraulic system according to Figure 8 of the ergonomic professional dishwasher, according to the invention. With particular reference to Figures 1, 1A, 1B, 2 and 3, the multi-floor industrial and professional dishwasher of the invention, generally indicated by 1, comprises a housing 2 generally of parallelepiped shape and made generally, but not necessarily, of metallic material, such as stainless steel, which presents a series of legs of support 9 for resting on the ground and which identifies an internal wash chamber 3, in which the dishes are contained, arranged on suitable support seats and/or baskets made of shelves 4 installed at certain heights, being the dishes 20 such as plates, cups, trays, bowls, etc., to be washed.

**[0021]** Inferiorly to each shelf 4, which may be fixed or mobile, so as to have more flexibility in determining various useful heights of passage of the dishes 20, are installed washing rotors or nozzles 21, which, as shown in detail in attached Figures 4, 5 and 6, have, on their upper surface, holes and slots 22, whose arrangement and dimensioning is specially designed in order to obtain maximum washing efficiency with the lowest passage of water; it is in order to minimize, compared to dishwashing machines of the traditional type, the water circulating in the storage tank 23 (visible in the attached Figure 7), so that the volume L2 of water, which remains in the storage tank 23, such as to achieve a level always higher than the level of water present in the rotor G of the washing pumps AP1, AP2, BP1, BP2 used in the hydraulic system of the dishwasher object of the invention, in order to obtain always the best performance.

**[0022]** Moreover, the storage tank 23 is shaped as a hopper in order to collect the water in the shortest time.

**[0023]** In the attached Figure 7 with L1 it is indicated the volume of water circulating in the pipelines and in the wash chamber 3; in preferred embodiments of the dishwasher according to the invention, this volume is less than the volume of water circulating in the dishwasher of known type, however it does not affect the quality of washing, because the study of its geometry and the arrangement of holes and slots 22 in each washing rotors or nozzles 21 ensure a good water pressure output by the nozzles 21 and a total coverage, as the distribution and direction, on the dishes 20 arranged on the shelves 4.

**[0024]** The shelves 4, where the support seats of the dishes 20 are provided, are easily accessible to the operator, being located at different (and variable) height levels in the wash chamber 3, along the vertical direction of development of the housing 2; also, preferably, but not necessarily, these shelves 4 are fixed inside the wash chamber 3, so as to perform the storage of dishes 20 directly within the dishwasher 1 and thus avoiding soiling and/or wetting the area in front of the front panel of the machine during the insertion or extraction of the shelves on which are arranged the dishes 20 and by whom the dishes 20 are removed, in the case such shelves are sliding on guides formed on the sides of the wash chamber 3 (as expected in most commercial dishwashers of known type).

**[0025]** The front panel of the dishwasher 1 includes a first lower portion 25 used for the positioning of a control panel to allow the user to programme various washing cycles of the dishwasher 1, a second lower portion 26, which includes a removable drawer where are arranged containers of detergents, rinses and/or disinfectants, and a third lower portion 24 where are housed the detergent substances, brighteners and/or disinfectants, in addition the rear panel of the dishwasher 1 includes a lower portion 30, inside which is housed a technical compartment where the drive means are housed (as shown in detail in the attached Figure 1 C).

**[0026]** Superiorly to the portions 24, 25, 26 to protect the wash chamber 3 one or more front doors 11 are provided, said doors being accessible to the operator for opening and/or closing of the dishwasher 1.

**[0027]** In exemplary and preferred embodiments, using two front doors 11, which are advantageously hinged on a steering column 27 located centrally at the front panel and which can be opened, by means of respective handles 28, according to the direction identified by the arrow F in the attached Figure 2; this method of opening, according to which each of the two front doors 11 can be opened and closed, alternatively, causes a further reduction of the overall dimensions, which allows to exploit also the space laterally adjacent to the housing 2 of the dishwasher.

**[0028]** In particular, for the opening of the front doors 11 it is first necessary to rotate the handle 28 and then pull the door 11, so that upon rotation of handle 28 it can already intervene the central processing and control unit, which, via a microcontroller, imparts a stop command to the pumps of the dishwasher causing the simultaneous interruption of the wash cycle in function and possibly the complete shutdown of the dishwasher 1; to ensure the safety of the operator, any interruption of the washing cycle is

also managed by a redundant system of four relays, which operate in such a way that the opening of the doors 11 immediately discontinues the supply of the pump and/or of the washing pumps.

**[0029]** In other embodiments, illustrative, but not limiting, of the present invention, rear doors 11 may also be placed, similar and/or equal to the front doors 11 and rotatably coupled to a rear central column 27 (as shown schematically in the attached Figures 1A and 1C), opposite to the front doors 11 and accessible to an operator for opening and closing of the housing 2 and, therefore, for access to the internal wash chamber 3 of the dishwasher 1 also on the opposite side with respect to the front doors 11.

**[0030]** In preferred embodiments, illustrative, but not limiting, the doors 11 have an outer glass 29 and a further inner glass (not shown in the figures), hinged to the same door 11 and resistant to high temperatures, which rests on a special perimeter seal placed on the outer contour of the wash chamber 3, so that to ensure a watertight seal that circulates in the wash chamber 3, also obviating to the expansion due to high temperatures.

**[0031]** In this way, between the two glass panes there is an air chamber which allows to obtain a natural cooling of the outer glass 29, which will thus have a "delta" of temperature (or temperature difference) with the working environment always less than 30-40 ° C, such as to comply with the safety regulations.

**[0032]** With particular reference to the attached figure 8, which shows an exemplary schematic of a preferred, but not limiting, of plumbing used in the dishwasher 1, object of the present invention, the system shown uses four wash pumps M1, M2, M1A, M2A, a discharge pump M4PS, eight washing rotors or nozzles 21 associated with respective fixed shelves 4, a resistance RV for heating the water inside the tank 23, a temperature probe B3 inside the wash chamber 3, three feeders M5, M9, M10 of detergent, rinse and sanitizer, softener (not shown), a salt container (not shown) and a finned battery BT to a condensation system, which also includes a condenser fan M11, a tank SBC, associated to an outdoor air filter FT, and a series of four nozzles UGC for the condensation of vapor inside the wash chamber 3.

**[0033]** This configuration makes the dishwasher 1 according to the invention extremely flexible and ergonomic for the user, both for the wide range of dishes 20 which can be washed, both for the possibility of placing the dishes 20 of one or more of the expected fixed shelves 4 (this also depends on the arrangement of shelves 4 themselves, which can be positioned at various heights, at the option of the operator, as well as by the number of shelves 4 actually installed in the machine); furthermore, according to the invention, the dishwasher can be used both at full load than at partial load, in the sense that they can be loaded by the user one or more sections or zones of the wash chamber 3 between the areas identified as an upper right area SD, an upper left area SS, a lower right area ID and a lower left area IS, each of which comprising at least one nozzle 21, associated with the respective shelf 4, and, preferably, comprising two cleaning nozzles 21, each of which is associated with a respective shelf 4 (as shown in Figure 8).

**[0034]** So, depending on the area SD, SS, ID, IS loaded by the operator with the dishes 20 to be washed, it is possible to choose a wash program dedicated, so that, consequently, this program provides for the activation of the wash pumps M1, M2, M1A, M2A attached to the rotors or nozzles 21 present in the one or in those areas (provided to the right or left with respect to a central axis of symmetry and vertical Y of the wash chamber 3 or above or below with respect to a central axis of symmetry and horizontal X of the wash chamber 3) where have been loaded the dishes 20 to be washed.

**[0035]** It is possible thus to obtain a considerable saving of water, envisaging a reduced capacity of the tank 23 placed in the reservoir bottom of the wash chamber 3, as well as selectable wash cycles; in this respect, it is possible, for example, provide for a cycle of pre-washing and/or cleaning (of economic type, standard or intensive) only in the upper zones SD and/or SS of the wash chamber 3, in order to obtain automatically, for only the force of gravity, a real cycle soaking of the dishes 20 present in the lower areas IS and/or ID of the chamber 3, as well as it is possible to provide a cycle of pre-washing and/or washing alternately in each zone SD, SS, ID, IS of the chamber 3, according to a default program (for example, by performing a first cycle in the upper left SS, then activating a second cycle in the upper right SD and simultaneously arresting the cycle of the area SS, as well as a third cycle in the lower right area ID at the end of the second cycle and a fourth cycle in the lower left IS at the end of the third cycle, and so on, according to a counterclockwise and thus activating only two washing nozzle 21 at a time).

**[0036]** The cycles of washing dishes 20 programmable on the machine according to the invention are the following:

- Soaking cycle,
- Washing cycle of economic type, standard or intensive (including a possible pre-washing and/or a washing step and/or at least one step of pre-rinsing and/or a rinsing phase and/or a phase condensation after rinsing),
- Thermal-disinfection cycle (comprising a phase of pre-wash, a washing phase, at least one phase of pre-rinsing, a phase of

thermal-disinfection and a phase of condensation after thermal-disinfection),

- Glasses cycle (comprising a phase of washing and/or rinsing phase glasses and/or a condensation phase after rinsing),
- Glasses cycle with cooling (including a washing phase and/or a rinsing phase glasses and/or a cooling phase glasses and/or a condensation phase after rinsing),
- A cycle of heating plates,
- Self-cleaning cycle of the battery BT.

**[0037]** With particular reference to the attached figure 8, the cycle of washing/rinsing is shown by the arrows LR, the condensation cycle is shown by the arrows C, the steam cycle is shown by the arrows V, while the cycle of self-cleaning of the battery BT is highlighted by arrows AP.

**[0038]** In detail, the soaking cycle provides that initially the discharge pump M4PS activates for precautionary emptying of the tank 23 and then start the load of water in the tank through the activation of the solenoid Y4 load cold water (at a maximum temperature of about 15° C), passing through the non-rebreathing valve DW and softeners AD, coupled to the solenoid valves Y3 (Y3 is the solenoid valve diverting exhaust brine, while Y2 is the solenoid diverter load brine), Y6 (solenoid diverting washing drums) and Y9 (solenoid diverter tub load / condensation).

**[0039]** Reached the level of water for which the volume of water in the tank 23 is equal to L2 (value measured by a probe and shown in the attached figure 7), is activated, for a predetermined time t1, the wash pump M1 or M2, depending on whether the programmed wash the area right DX or left SX the chamber 3, i.e. pump M1A or M2A if the pump is programmed to wash less, then the pump M1 or M2 turns off and spends a fixed time t2, at the end which the pump M1A or M2A (depending on the area right or left of the chamber 3 concerned by washing) activates for the time t1 and then turns off (this alternation of activations and off of the pumps is carried out also for the remaining two pumps washing for a pre-phase number of turns).

**[0040]** Meanwhile, the load of water in the tank 23 continues and when it reaches a level such that the volume of water reaches the value L1 (value measured by a probe and shown in the attached figure 7), the loading solenoid valve Y4 is deactivated.

**[0041]** During the load of water in the tank 23 the resistance RV of the tank 23 is turned off and, for example, which is activated by placing the pump M2 as the first wash pump (activation of a specific pump depends, as mentioned, from the loading area SS and/or SD and/or IS and/or ID when it is chosen to perform the washing cycle), the sequence of activation of the pumps is as follows:

- Pump start M2 for a time t3;
- Pump start M1 for a time t3;
- Pump start M2A for a time t4;
- Pump start M1A for a time t4.

**[0042]** Furthermore, during that cycle of operation of the pumps it is also turned on a mode of activation and deactivation of the pumps (soft-start, soft-stop: power modulated), so that the same do not start and will not stop at the maximum flow to optimize the flow of water in the various washing nozzle 21.

**[0043]** The above sequence is repeated for a preset number of turns for the soaking cycle, after which the discharge pump M4PS is activated in order to empty the tank 23.

**[0044]** The wash cycle can be of economic type, standard or intensive and may comprise the steps of pre-washing, washing, pre-rinsing, rinsing and condensation after rinsing.

**[0045]** In particular, the step of pre-washing initially involves the loading of the tank 23 through the activation of the solenoid diverter Y1 hot water (at a maximum temperature of about 55 ° C) passing through the check valve DW and softeners AD.

**[0046]** Reached the level of water for which the volume of water in the tank 23 is equal to L2 (value measured by a probe and shown in the attached figure 7), is activated, for a predetermined time t1, the wash pump M1 or M2, depending on whether the programmed wash the area right DX or left SX the chamber 3, i.e. pump M1A or M2A if the pump is programmed to wash less, then the pump M1 or M2 turns off and spends a fixed time t2, at the end which activates the pump M1A or M2A (depending on the area right or left of the chamber 3 concerned by washing) for the time t1 and then turns off (this alternation of activations and off

of the pumps is carried out also for the remaining two pumps washing for a preset number of turns).

**[0047]** Meanwhile, the load of water in the tank 23 continues and when it reaches a level such that the volume of water reaches the value L1 (value measured by a pressure linear PL, shown in particular in the attached Figure 7), the solenoid valve Y1 turns off.

**[0048]** During the load of water in the tank 23 the resistance RV of the tank 23 is activated, after having reached the level L2, and, for example, which is activated by placing the pump M2 as the first wash pump (activation of a specific pump depends, as mentioned, from the loading area SS and/or SD and/or IS and/or ID when you choose to perform the washing cycle), the sequence of activation of the pumps is as follows:

- Pump start M2 for a time t3;
- Pump start M1 for a time t3;
- Pump start M2A for a time t4;
- Pump start M1A for a time t4.

**[0049]** Furthermore, during that cycle of operation of the pumps a mode of activation and deactivation of the pumps (soft-start, soft-stop: power modulated) is also turned on, so that the same do not start and will not stop at the maximum flow to optimize the flow of water in the various washing nozzles 21.

**[0050]** The above sequence is repeated until reaching a preset temperature value for this stage of pre-washing; to reaching this temperature value the sequence repeats for a preset number of turns for this stage, at the end of which the discharge pump M4PS activates for emptying the tank 23.

**[0051]** The washing phase provides initially the load of the tank 23 through the activation of the solenoid Y1 hot water (at a maximum temperature of about 55 ° C) passing through the check valve DW and softeners AD. Reached the level of water for which the volume of water in the tank 23 is equal to L2 (value measured by a probe and shown in the attached figure 7), is activated, for a predetermined time t1, the wash pump M1 or M2, depending on whether the programmed wash the area right DX or SX left the chamber 3, i.e. pump M1A or M2A if the pump is programmed to wash less, then turn off the pump M1 or M2 and spends a fixed time t2, at the end which activates the pump M1A or M2A (depending on the area right or left of the chamber 3 concerned by washing) for the time t1 and then turns off (this alternation of activations and deactivations of the pumps is carried out also for the remaining two pumps washing for a preset number of turns).

**[0052]** Meanwhile, the load of water in the tank 23 goes on and when it reaches a level such that the volume of water reaches the value L1 (value measured by a probe and shown in the attached figure 7), the loading solenoid valve Y1 is deactivated.

**[0053]** During the load of water in the tank 23 the resistance RV of the tank 23 is activated, after having reached the level L2, and, for example, which is activated by placing the pump M2 as the first wash pump (activation of a specific pump depends, as mentioned, from the loading area SS and/or SD and/or IS and/or ID when it is chosen to perform the wash cycle), the sequence of activation of the pumps is as follows:

- Pump start M2 for a time t3;
- Pump start M1 for a time t3;
- Pump start M2A for a time t4;
- Pump start M1A for a time t4.

**[0054]** Furthermore, during that cycle of operation of the pumps a mode of activation and deactivation of the pumps (soft-start, soft-stop: power modulated) is also turned on, so that the same do not start and will not stop at the maximum flow to optimize the flow of water in the various washing nozzles 21.

**[0055]** To a default value of temperature for this washing phase the detergent dispenser M5 is activated for a preset time and the above sequence is repeated until reaching a temperature value preset for this washing phase; to the achievement of this temperature value repeats the sequence for a preset number of turns for this stage, at the end of which activates the discharge pump M4PS for emptying of the tank 23, the solenoid valve is activated again Y1 to pass water hot, through the check valve DW and softeners AD, through the battery BT for a washing time t5 of said condensing battery BT and, therefore, it reactivates the

discharge pump M4PS for emptying the tank 23.

**[0056]** The pre-rinse initially involves the loading of the tank 23 through the activation of the solenoid Y1 hot water (at a maximum temperature of about 55 ° C) passing through the check valve DW and softeners AD.

**[0057]** Reached the level of water for which the volume of water in the tank 23 is equal to L2 (value measured by the pressure switch linear PL), wash pumps are activated as for the following sequence (always placing, which indicative example and illustration, but not limitative, which is activated the pump M2 as the first wash pump, as a consequence of the loading area SS and/or SD and/or IS and/or ID of the chamber 3 where it is chosen to perform the cycle):

- Pump start M2 for a time t6;
- Pump start M1 for a time t6;
- Pump start M2A for a time t6;
- Pump start M1A for a time t6.

**[0058]** In this phase the resistance RV of the tank 23 is turned off and also the system soft-start and soft-stop of the pumps is disabled.

**[0059]** The sequence is repeated for a preset number of turns for this stage of pre-rinsing, at the end of which activates the discharge pump M4PS for emptying of the tank 23.

**[0060]** The rinsing phase initially involves the loading of the tank 23 through the activation of the solenoid Y1 hot water (at a maximum temperature of about 55 ° C) passing through the check valve DW and softeners AD.

**[0061]** Reached the level of water for which the volume of water in the tank 23 is equal to L2 (value measured by the pressure switch linear PL), the wash pump M1 or M2 is activated, for a predetermined time t1, depending on whether programmed washing in the right DX or SX left the chamber 3, i.e. pump M1A or M2A if the pump is programmed to wash less, then the pump M1 or M2 turns off and spends a fixed time t2, after which pump M1A or M2A turns on (depending on the area of the chamber 3 DX or SX affected by washing) for the time t1 and then turns off (this alternation of activations and deactivations of the pumps is carried out also for the remaining two wash pumps for a preset number of RPM).

**[0062]** Meanwhile, the load of water in the tank 23 goes on and when it reaches a level such that the volume of water reaches the value L1 (measured value by the pressure switch linear PL), the loading solenoid valve Y1 is deactivated.

**[0063]** During the load of water in the tank 23 the resistance RV of the tank 23 is activated, after having reached the level L2, and, for example, which is activated by placing the pump M2 as the first wash pump (activation of a specific pump depends, as mentioned, from the loading area SS and/or SD and/or IS and/or ID when you choose to perform the washing cycle), the sequence of activation of the pumps is as follows:

- Pump start M2 for a time t3;
- Pump start M1 for a time t3;
- Pump start M2A for a time t4;
- Pump start M1A for a time t4.

**[0064]** Furthermore, during that cycle of operation of the pumps a mode of activation and deactivation of the pumps (soft-start, soft-stop: power modulated) is also turned on, so that the same do not start and will not stop at the maximum flow to optimize the flow of water in the various washing nozzles 21.

**[0065]** To a default temperature value for this rinsing step the fan M11 activates for cooling the battery BT for the condensation of the vapors coming out of the wash chamber 3, as well as the rinse dispenser M9 for a preset time and the sequence above is repeated until reaching a temperature value preset for this rinsing phase; to reaching this temperature the sequence is repeated for a preset number of turns for this stage, at the end of which turns off the fan M11 leaving the water in the tank 23.

**[0066]** The rinsing phase of the glasses can be considered equal to the previous phase, with only slight differences relating to the values of pre-phase temperature.

**[0067]** The cooling phase of the glasses initially involves the loading of the tank 23 through the activation of the solenoid Y4 cold water (at a maximum temperature of about 15 ° C) passing through the check valve DW and softeners AD.

**[0068]** Reached the level of water for which the volume of water in the tank 23 is equal to L2 (value measured by the pressure switch linear PL), wash pumps are activated as indicated in the sequence below (always placing, which is an indicative example, but not limitative, which is activated the pump M2 as the first wash pump, as a consequence of the loading area SS and / or SD and / or IS and / or ID of the chamber 3 where it chooses to perform the cycle):

- Pump start M2 for a time t6;
- Pump start M1 for a time t6;
- Pump start M2A for a time t6;
- Pump start M1A for a time t6.

**[0069]** In this phase the resistance RV of the tank 23 is turned off and also the system soft-start and soft-stop of the pumps is disabled.

**[0070]** The sequence is repeated for a preset number of turns for this cooling phase, after which activates the discharge pump M4PS for emptying the tank 23.

**[0071]** The condensation step after rinsing always begins with the tank 23 filled with water left from the previous step and if there is no water in the tank interrupts the cycle.

**[0072]** After a predetermined period of time t7, it activates the solenoid diverter Y9 for the entire phase, up to about 5 seconds after the end of that phase.

**[0073]** Then, it activates the solenoid valve Y4 cold water at a temperature of about 15-25 ° C; the water passes through the non-rebreathing valve DW and softeners AD and exits from the nozzles of condensation UGC, so slipping on the inner walls of wash chamber 3, so as to condense the steam within the same chamber 3 with a timed sequence.

**[0074]** At this point, it activates the discharge pump M4PS for a predetermined time t8 for the emptying of the tank 23 is reached if the maximum water level in the tank and is activated again the discharge pump M4PS. The step of thermal-disinfection initially involves the loading of the tank 23 through the activation of the solenoid Y1 hot water (at a maximum temperature of about 55 ° C) passing through the check valve DW and softeners AD.

**[0075]** Reached the level of water for which the volume of water in the tank 23 is equal to L2 (value measured by a probe and shown in the attached figure 7), the wash pump M1 or M2 is activated, for a predetermined time t1, depending on whether the programmed wash the area right DX or left SX the chamber 3, i.e. pump M1A or M2A if the pump is programmed to wash less, then turn off the pump M1 or M2 and spends a fixed time t2, at the end which activates the pump M1A or M2A (depending on the area right or left of the chamber 3 concerned by washing) for the time t1 and then turns off (this alternation of activations and off of the pumps is carried out also for the remaining two pumps washing for a preset number of turns).

**[0076]** Meanwhile, the load of water in the tank 23 continues and when it reaches a level such that the volume of water reaches the value L1 (value measured by a probe and shown in the attached figure 7), the loading solenoid valve Y1 is deactivated.

**[0077]** During the load of water in the tank 23 the resistance RV of the tank 23 is activated, after having reached the level L2, and, for example, which is activated by placing the pump M2 as the first wash pump (activation of a specific pump depends, as mentioned, from the loading area SS and/or SD and/or IS and/or ID when you choose to perform the washing cycle), the sequence of activation of the pumps is as follows:

- Pump start M2 for a time t3;
- Pump start M1 for a time t3;
- Pump start M2/A for a time t4;
- Pump start M1/A for a time t4.

**[0078]** Furthermore, during that cycle of operation of the pumps is also active mode of activation and deactivation of the pumps (soft-start, soft-stop: power modulated), so that the same do not start and will not stop at the maximum flow to optimize the flow of water in the various washing nozzles 21.

**[0079]** To a default value of temperature for this phase of thermal-disinfection activates the fan M11 for cooling the battery BT for the condensation of the vapors exiting from the wash chamber 3, as well as the rinse dispenser M9 for a preset time and the above sequence is repeated until reaching a temperature value preset for this phase of thermal-disinfection, maintaining that value of temperature (about 93 ° C) for a phase time (about 10 minutes).

**[0080]** The phase ends leaving the water in the tank 23 and the fan off M11. The condensation step after thermal-disinfection always begins with the tank 23 filled with water left from the previous step and if there is no water in the tank interrupts the cycle.

**[0081]** After a predetermined period of time  $t_7$ , it activates the solenoid diverter Y9 for the entire phase, up to about 5 seconds after the end of that phase.

**[0082]** Then, it activates the solenoid valve Y4 cold water at a temperature of about 15-25° C and the water passes through the non-rebreathing valve DW and softeners AD and exits from the nozzles of condensation UGC, so slipping on the inner walls of wash chamber 3, so as to condense the steam within the same chamber 3 with a timed sequence longer than the expected sequence at the stage of condensation after rinsing; at this point, it activates the discharge pump M4PS for a predetermined time  $t_8$  for emptying the tank 23 is reached if the maximum water level in the tank and is activated again the discharge pump M4PS at the end phase.

**[0083]** The cycle of heating plates provides that initially activates the discharge pump M4PS for precautionary an emptying of the tank 23 and then start the load of water in the tank through the activation of the solenoid Y1 of load of the hot water, passing through the valve antireflux DW and softeners AD.

**[0084]** Reached the level of water for which the volume of water in the tank 23 is equal to L2 (value measured by the pressure switch linear PL), is activated, for a predetermined time  $t_1$ , the wash pump M1 or M2, depending on whether programmed washing in the right DX or SX left the chamber 3, i.e. pump M1A or M2A if the pump is programmed to wash less, then turn off the pump M1 or M2 and spends a fixed time  $t_2$ , after which you turn pump M1A or M2A (depending on the area of the chamber 3 DX or SX affected by washing) for the time  $t_1$  and then turns off (this alternation of activations and off of the pumps is carried out also for the remaining two washing pumps for a preset number of RPM).

**[0085]** Meanwhile, the load of water in the tank 23 continues and when it reaches a level such that the volume of water reaches the value L1 (value measured by a probe and shown in the attached figure 7), the loading solenoid valve Y1 is deactivated.

**[0086]** During the load of water, it activates the resistance RV of the tank 23, after having reached the level L2, and, for example, which is activated by placing the pump M2 as the first wash pump (activation of a specific pump depends, as mentioned, from the loading area SS and/or SD and/or IS and/or ID when you choose to perform the wash cycle), the sequence of activation of the pumps is as follows:

- Pump start M2 for a time  $t_3$ ;
- Pump start M1 for a time  $t_3$ ;
- Pump start M2A for a time  $t_4$ ;
- Pump start M1A for a time  $t_4$ .

**[0087]** Furthermore, during that cycle of operation of the pumps is also turned on a mode of activation and deactivation of the pumps (soft-start, soft-stop: power modulated), so that the same do not start and will not stop at the maximum flow to optimize the flow of water in the various washing nozzles 21.

**[0088]** The sequence of activation of the pumps is repeated until reaching a preset temperature value for this cycle of heating plates, after which the sequence is not repeated, but, after a predetermined time interval  $t_7$ , it activates the solenoid diverter Y9 (which is deactivated after the end of that phase) and the solenoid valve Y4, from which water enters at a temperature of about 15-25° C, which passes through the check valve DW and softeners AD and, exiting from the nozzles of condensation UGC, slips on the inner walls of the wash chamber 3, condensing the steam within the same chamber 3 with a timed sequence.

[0089] At this point, it activates the discharge pump M4PS for a predetermined time  $t_8$  for the emptying of the tank 23 is reached if the maximum water level in the tank and is activated again the discharge pump M4PS at end of cycle.

[0090] The self-cleaning cycle of the dishwasher initially involves the activation of the discharge pump for an emptying precautionary M4PS the tank 23 and then begins the load of water in the tank through the activation of the solenoid Y1 hot water supply, passing for the non-rebreathing valve and DW softeners AD.

[0091] Reached the level of water for which the volume of water in the tank 23 is equal to L2 (value measured by a probe and shown in the attached figure 7), is activated, for a predetermined time  $t_1$ , the wash pump M1 or M2, depending on whether the programmed wash the area right DX or SX left the chamber 3, ie pump M1A or M2A if the pump is programmed to wash less, then turn off the pump M1 or M2 and spends a fixed time  $t_2$ , at the end which activates the pump M1A or M2A (depending on the area right or left of the chamber 3 concerned by washing) for the time  $t_1$  and then turns off (this alternation of activations and off of the pumps is carried out also for the remaining two pumps washing for a pre-phase number of turns).

[0092] Meanwhile, the load of water in the tank 23 continues and when it reaches a level such that the volume of water reaches the value L1 (measured value by the pressure switch linear PL), the loading solenoid valve Y1 is deactivated.

[0093] During the load of water, it activates the resistance RV of the tank 23, after having reached the level L2, and, for example, which is activated by placing the pump M2 as the first wash pump (activation of a specific pump depends, as said, from the loading area SS and/or SD and/or IS and/or ID when it is chosen to perform the washing cycle), the sequence of activation of the pumps is as follows:

- Pump start M2 for a time  $t_3$ ;
- Pump start M1 for a time  $t_3$ ;
- Pump start M2A for a time  $t_4$ ;
- Pump start M1A for a time  $t_4$ .

[0094] Furthermore, during that cycle of pump operation is also turned on a mode of activation and deactivation of the pumps (soft-start, soft-stop: power modulated), so that the same do not start and will not stop at the maximum flow to optimize the flow of water in the various washing nozzles 21.

[0095] To a preset temperature value the dispenser sanitizing M10 activates for a phase time and, therefore, the sequence of activation of the pumps is repeated until reaching a preset temperature value for this round of self-cleaning, after which does not repeat the sequence, but, after a predetermined time interval  $t_7$ , it activates the solenoid diverter Y9 (which is deactivated after the end of that phase) and the solenoid valve Y4, from which water enters at a temperature of about 15-25° C, passing through the non-rebreathing valve DW and softeners AD and, exiting from the nozzles of condensation UGC, slips on the inner walls of the wash chamber 3, condensing the steam within the same chamber 3 with a timed sequence.

[0096] At this point, it activates the discharge pump M4PS for a predetermined time  $t_8$  for emptying the tank 23 if the maximum water level in the tank is reached and the discharge pump M4PS is activated again.

[0097] Finished the emptying of tank 23, the loading of the tank 23 starts again through the activation of the solenoid Y1 hot water, which passes through the check valve DW and softeners for AD.

[0098] Reached the level of water for which the volume of water in the tank 23 is equal to L2 (value measured by the pressure switch linear PL), wash pumps are activated as sequence below (always placing, which indicative example and illustration, but not limitative, which is activated the pump M2 as the first wash pump, as a consequence of the loading area SS and/or SD and/or IS and/or ID of the chamber 3 where it is chosen to perform the cycle):

- Pump start M2 for a time  $t_6$ ;
- Pump start M1 for a time  $t_6$ ;
- Pump start M2A for a time  $t_6$ ;
- Pump start M1A for a time  $t_6$ .

[0099] In this phase the resistance RV of the tank 23 is turned off and also the system soft-start and soft-stop of the pumps is

disabled.

**[0100]** The sequence is repeated for a preset number of turns for this stage of self-cleaning, after which the discharge pump M4PS is activated for emptying of the tank 23.

**[0101]** It should be noted, finally, that the beginning of each cycle activates the discharge pump M4PS for precautionary an emptying of the tank 23. With particular reference to the attached Figure 10, which shows in detail the operation of the washing pumps, in an exemplary embodiment and preferred, but not limiting, of the dishwasher 1 according to the present invention, as well as the cycle of washing/rinsing (arrows LR), are used, as already shown in attached Figures 7 and 8, four wash pumps AP1, AP2, BP1, BP2 that connect directly the washing rotors or nozzles 21 in pairs, thanks to respective fittings RD, suitably dimensioned, so that each pump AP1, AP2, BP1, BP2 managing two washing nozzles 21.

**[0102]** In this case, there are four washing zones: an upper right area, an upper left area, a lower right area and a lower left area.

**[0103]** This embodiment is very advantageous, since it greatly reduces the consumption of water, makes optimum pump performance, enables an automatic cleaning of the washing pipes (for natural fall of the water) and economize in general operating costs of the dishwasher 1.

**[0104]** An alternative embodiment of the operation of the pumps of washing in the dishwasher 1 is shown in the attached Figure 9 (when the cycle of washing/rinsing is highlighted with arrows LR), according to which there are two washing pumps AP, BP, which are series-connected with respective servo-motor valves ASM, BSM, which manage the flow of water from a respective pump AP, BP on the washing nozzles 21, through the respective ducts ASM1, ASM2 and BSM1, BSM2 and Y-shaped fittings RD.

**[0105]** In this case, it is dealt two washing rotors or nozzles 21 at a time, because each servo-motor valve ASM, BSM has opened only one output at a time, so it is as if there are four zones of washing in chamber 3, which, however, can never be covered simultaneously, since it activates only one pump at a time.

**[0106]** This embodiment is very advantageous also in terms of reducing consumption of water and also from the point of view of performance of the pumps.

**[0107]** A further alternative embodiment of the operation of the pumps of washing in the dishwasher 1 is shown in the attached Figure 11 (when the cycle of washing/rinsing is highlighted with arrows LR), according to which there are two washing pumps AP, BP, in each of which parallel-connected with four servo-motor valves, respectively ASM and BSM, each placed at the inlet of each washing rotor or nozzle 21; in this case it is as if there were eight zones of washing, as it is possible to start one or two washing nozzle 21 at a time (also connected to the same pump AP or BP).

**[0108]** Even this embodiment is very advantageous both from the point of view of the reduction of consumption of water both from the point of view of performance of the washing pumps.

**[0109]** In the attached Figures 13 and 14 are also shown further embodiments of the hydraulic system of washing, according to which it is possible to use a single wash pump AP and more servo-motor valves ASM, BSM in series and/or in parallel, each of which connected, by respective fittings, two washing nozzles 21 (as shown in the attached Figure 13) or to a respective nozzle 21 (as shown in the attached Figure 14).

**[0110]** In particular, in the attached Figure 13 is shown an embodiment with a pump AP, a servo-motor valve BSR and four servo-motor valves BSM, with RD fittings that connect each servo-motor valve BSM two washing nozzles 21 which, therefore, can be operated two at a time.

**[0111]** In the attached Figure 14 is shown a further embodiment with a pump AP, a servo-motor valve BSR and eight servo-motor valves BSM, each of which connected to a respective washing nozzle 21; the washing nozzle 21, in this case, may be actuated as one or more at a time. Finally, the scheme shown in the attached Figure 12 shows the operation of the condensation of vapors system used in the dishwasher of the invention (the condensation cycle is indicated with arrows C, while the cycle of self-cleaning of the battery BT is indicated with the arrows AP).

**[0112]** There are two distinct condensations that occur in the dishwasher 1 according to the present invention: one that occurs during the washing cycle and one that occurs at the end of the wash cycle.

[0113] In the first case, during the washing cycle, for obvious reasons vapors are created inside the wash chamber 3, which is hermetically sealed; since, then, the dishwasher 1 is a watertight machine, which does not have a link direct with the outside, the excess steam must exit, for physical reasons, by the same.

[0114] So, in order not to allow the vapors to enter in the work environment of the operator, the same is "knocked down" by passing it (preferably in a natural way) through a finned battery BT, which is cooled by a fan M11, so that the aforesaid steam condenses and is collected in a special condensate collection tank SBC; thanks to the realization of appropriate openings and the application of a filter FT SBC associated with the tank for collecting the condensate, from such reservoir SBC comes out only dry air and unpolluted.

[0115] Furthermore, at the end of the wash cycle is also necessary to "break down" the vapors remaining inside the wash chamber 3; to do this, it is used the nozzles UGC, places internally and on the upper part of the wash chamber 3, which inject cold water, which slides along the inner side walls of the wash chamber 3.

[0116] In this way, the steam inside the condensation chamber 3 and the void left by the steam is compensated for aspirating air from outside, which, passing from the filter FT (so that air is sucked clean, unpolluted), runs in the opposite direction the output of the vapors V and enters inside of the wash chamber 3, thus creating a physical balance; the condensation that occurs inside the wash chamber 3, over which "break down" the vapors, allows also to dry the dishes 20 placed inside the chamber 3, thus avoiding the use of other systems, such as heat pumps, definitely more expensive.

[0117] Based on the foregoing, it is understood, therefore, that the ergonomic professional dishwasher invention achieves the objects and realizes the advantages previously mentioned.

[0118] Upon implementation, changes may be made to the professional dishwasher of the invention consisting, for example, in a box-like enclosure of constructive conception different from that illustrated in the accompanying drawings; in addition, in other embodiments, not shown, the ergonomic professional dishwasher claimed herein may include a different number of shelves and, therefore, of washing nozzles, this number could vary depending on the choice of construction and the demands of the market.

[0119] It should be noted, moreover, that the ergonomic professional dishwasher object of the present invention may be used for washing, drying and stowage of not only dishes, but also of any other furnishings, not only home dishes.

[0120] It's clear, finally, that numerous other variations may be made to the ergonomic professional dishwasher in exam without departing from the principles of novelty inherent in the inventive idea, just as it is clear that, in the practical embodiment of the invention, the materials, the shapes and the dimensions of the illustrated details can be any, depending on requirements, and may be replaced with other technically equivalent. Where the constructional characteristics and techniques, mentioned in the subsequent claims, are followed by reference numbers or signs, those reference signs have been introduced with the sole purpose of increasing the intelligibility of the claims themselves and, consequently, they do not present any limiting effect on the interpretation of each element identified, purely by way of example, by such reference signs.

## REFERENCES CITED IN THE DESCRIPTION

This list of references cited by the applicant is for the reader's convenience only. It does not form part of the European patent document. Even though great care has been taken in compiling the references, errors or omissions cannot be excluded and the EPO disclaims all liability in this regard.

### Patent documents cited in the description

- EP1586265A1 [0006]

**Patentkrav**

1. Ergonomisk professionel opvaskemaskine (1) omfattende et hus (2) med et indre vaskekammer (3), i hvilket servicen (20) som skal vaskes er indeholdt, 5 hvilken service (20) er anbragt på hylder (4) installeret ved bestemte højder, hvor hylderne (4) er associeret med vaskerotorer eller -dyser (21), som har huller og slidser (22) til at passere vandet kommende fra mindst en opbevaringsbeholder (23) og taget fra vandforsyningen, hvor beholderen (23) er placeret ved bunden af opvaskemaskinen (1) og er udstyret med mindst et varmeelement (RV) og 10 mindst en udledningpumpe (M4PS), hvor blandt opbevaringsbeholderen (23) og vaskerotorerne (21) der er mindst to pumper (AP, BP, AP1, AP2, BP1, BP2, M1, M2, M1A, M2A), hver af hvilke er forbundet, via rørledninger, til mindst en vaskerotor (21) som er placeret i et respektivt afsnit eller område (SX, DX, SS, SD, IS, ID) af vaskekammeret (3), hvor afsnittene eller områderne (SX, DX, SS, 15 SD, IS, ID) er overliggende på og/eller tilstødende hinanden og hvor mindst en vaskerotorerne (21), som er positioneret i et første afsnit eller område (SX, DX, SS, SD, IS, ID) af vaskekammeret (3), aktueres alternerende med mindst en af vaskerotorerne (21), som er positioneret i et andet område (SX, DX, SS, SD, IS, ID) af vaskekammeret (3), **kendetegnet ved at** mindst to pumper (AP1, AP2, 20 BP1, BP2) forbinder mindst to vaskerotorer (21) ved hjælp af relative fittings (RD) og hver pumpe (AP1, AP2, BP1, BP2) derved er forbundet til mindst to vaskerotorer (21), hvor de mindst to vaskerotorer (21) er placeret i et samme afsnit eller område (SX, DX, SS, SD, IS, ID) af vaskekammeret (3).

25 **2.** Ergonomisk opvaskemaskine (1) ifølge krav 1, **kendetegnet ved at** to vaskerotorer (21) som er positioneret i det første afsnit eller område (SX, DX, SS, SD, IS, ID) af vaskekammeret (3) er aktueret alternerende med to vaskerotorer (21) som er placeret i det andet afsnit eller område (SX, DX, SS, SD, IS, ID) af vaskekammeret (3).

30

**3.** Ergonomisk opvaskemaskine (1) ifølge krav 1, **kendetegnet ved at** to af pumperne (AP, BP) er serieforbundet med respektive servomotor-ventiler (ASM, BSM), som styrer strømmen af vand fra en respektiv pumpe (AP, BP) til to vaskerotorer (21), igennem respektive kanaler (ASM1, ASM2; BSM1, BSM2) og

formede fittings (RD), således at hver af de to pumper (AP, BP), som er individuelt aktiveret, er forbundet til to vaskerotorer (21) ad gangen.

4. Ergonomisk opvaskemaskine (1) ifølge krav 3, **kendetegnet ved at** to af  
5 pumperne (AP, BP) er parallelforbundet med respektive servomotor-ventiler (ASM, BSM), hver placeret ved indløbet af hver vaskerotor (21), hvor hver af pumperne (AP, BP) er forbundet til en eller to vaskerotorer (21), således at hver pumpe (AP, BP) aktiverer en eller to vaskerotorer (21) ad gangen.
- 10 5. Ergonomisk opvaskemaskine (1) ifølge mindst et af de foregående krav, **kendetegnet ved** det faktum at faserne af aktivering og deaktivering af pumperne (AP, BP, AP1, AP2, BP1, BP2, M1, M2, M1A, M2A) er lavet af en modulationseffekt, på sådan en måde at pumperne (AP, BP, AP1, AP2, BP1, BP2, M1, M2, M1A, M2A) ikke starter og ikke stopper ved den maksimale strømning,  
15 for at optimere vandstrømmen i vaskerotorerne (21).
6. Ergonomisk opvaskemaskine (1) ifølge mindst et af de foregående krav, **kendetegnet ved at** i hvert af afsnittene eller områderne (SX, DX, SS, SD, ID, IS) af vaskekammeret (3) forudindstillede vaskecykluser er lavet, hvor  
20 cykluserne er programmerbare i forhold til temperatur, tid og vand, vaskemiddel, skyllemiddel og/eller desinficeringsmiddel, cykluserne inkluderer mindst en iblødsætningscyklus og/eller mindst en økonomisk, standard eller intensiv vaskecyklus, inkluderende en mulig forvasknings- og/eller en vaskefase og/eller mindst en forskylnings- og/eller en skylnings- og/eller en kondenseringsfase efter  
25 skylning, og/eller mindst en termisk desinficerende cyklus, inkluderende en forvaskningsfase, en vaskefase, mindst en forskylningsfase, en termisk desinficerende fase og en kondenseringsfase efter termisk desinficering, og/eller mindst en glascyklus, inkluderende en vaskefase og/eller en glasskylnings- og/eller en kondenseringsfase efter skylning, og/eller mindst en glascyklus med  
30 afkøling, inkluderende en vaskefase og/eller en glasskylningsfase og/eller en glasafkølingsfase og/eller en kondenseringsfase efter skylning, og/eller mindst en tallerkenopvarmningscyklus og/eller mindst en selvrengørende cyklus.
7. Ergonomisk opvaskemaskine (1) ifølge mindst et af de foregående krav,  
35 **kendetegnet ved at** opbevaringsbeholderen (23) er formet som en tragt og

indeholder en volumen (L2) af vand, som tilbagebliver efter at have sendt vand til vaskerotorerne (21), således for at opnå et niveau altid højere end niveauet af vand til stede i rotoren (G) af pumperne (AP, BP, AP1, AP2, BP1, BP2, M1, M1A, M2, M2A).

5

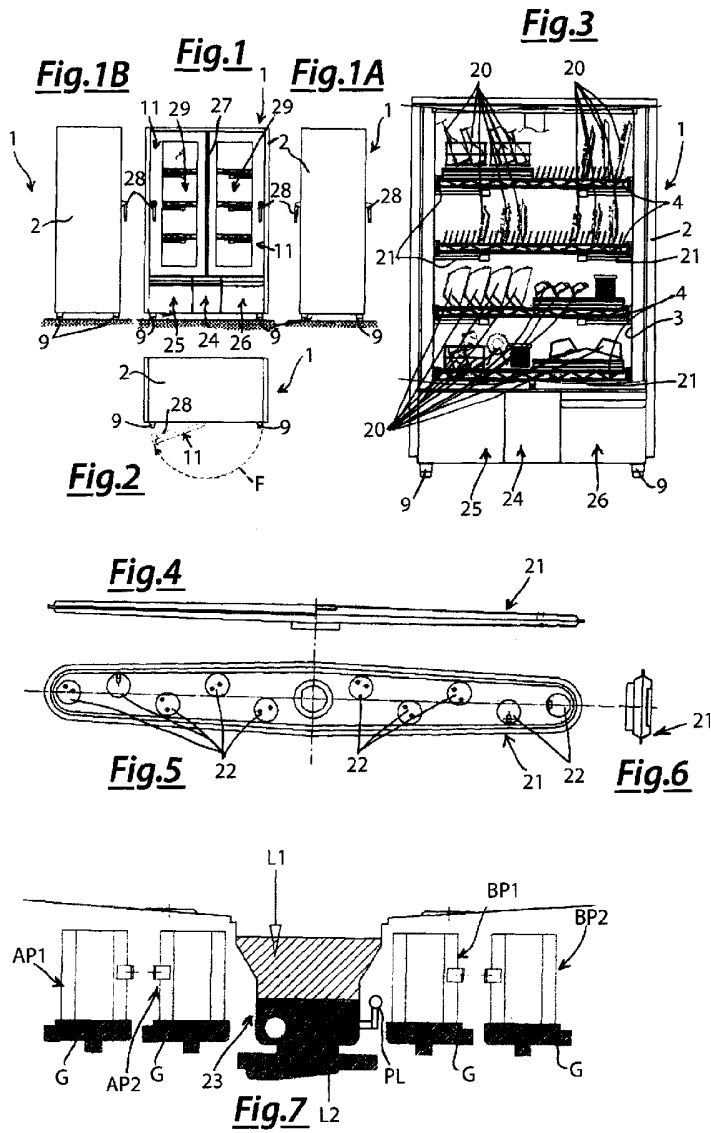
**8.** Ergonomisk opvaskemaskine (1) ifølge mindst et af de foregående krav, **kendetegnet ved at** vaskekammeret (3) lukkes af en eller flere fordøre (11), som er tilgængelige for en operatør via mindst et håndtag (28), og i særdeleshed af mindst to fordøre (11), som er hængslet på en søjle (27) placeret centralt i  
10 vaskekammeret (3), således at en dør ad gangen kan åbnes og lukkes.

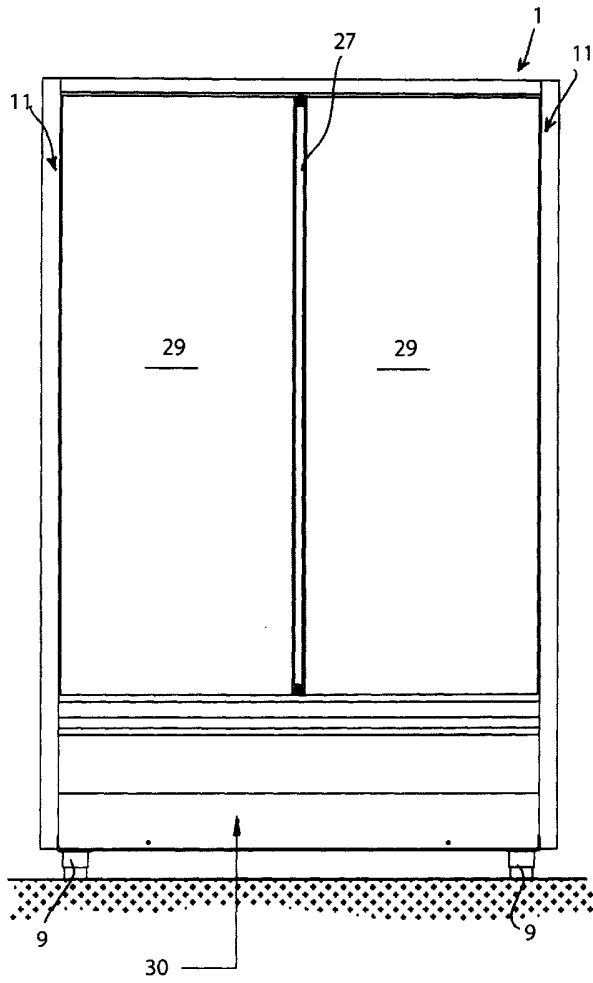
**9.** Ergonomisk opvaskemaskine (1) ifølge krav 8, **kendetegnet ved at** bagdøre er tilvejebragt, som er modstående fordøre (11) og som er tilgængelige for en operatør til at åbne og lukke vaskekammeret (3) selv ved en modsat side i forhold  
15 til fordøre (11).

**10.** Ergonomisk opvaskemaskine (1) ifølge mindst et af de foregående krav, **kendetegnet ved at** dampene (V) inden i vaskekammeret (3) under vaskecyklusserne føres mod og igennem et ribbatteri (BT), som er uden for  
20 vaskekammeret (3) og som afkøles af en blæser (M 11), således at dampene (V) kondenserer og kondensen samles i en beholder (SBC), hvor beholderen (SBC) har egnede åbninger til indtrædelsen af den udvendige luft og er associeret med et filter (FT) til at opnå tør og ikke-forurenede luft.

25 **11.** Ergonomisk opvaskemaskine (1) ifølge krav 10, **kendetegnet ved at** en serie af dyser (UGC) er placeret inden i og oven på vaskekammeret (3), hvor dyserne (UGC) er i stand til at indsprøjte koldt vand som glider langs de indvendige sidevægge af vaskekammeret (3), således at dampene (V) som forbliver inden i vaskekammeret (3) ved slutningen af vaskecyklusserne  
30 kondenserer, hvor udvendig luft også indsuges og indsættes i vaskekammeret (3), hvor luften passerer igennem filteret (FT) for at fylde tomrummet efterladt af dampene (V), dampene (V) som kondenserer inden i vaskekammeret (3) også tillader tørringen af servicen (20) placeret inden i vaskekammeret (3).

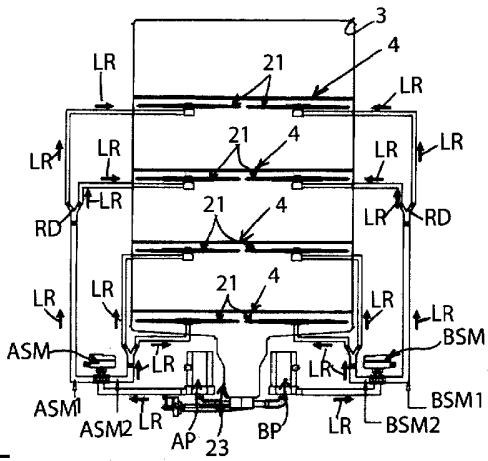
DRAWINGS



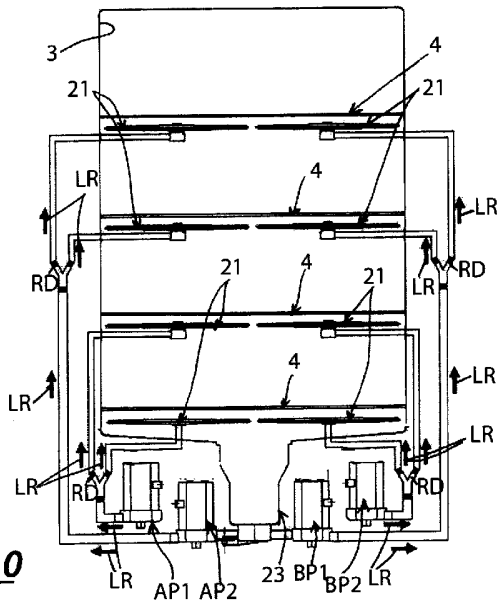


**Fig.1C**

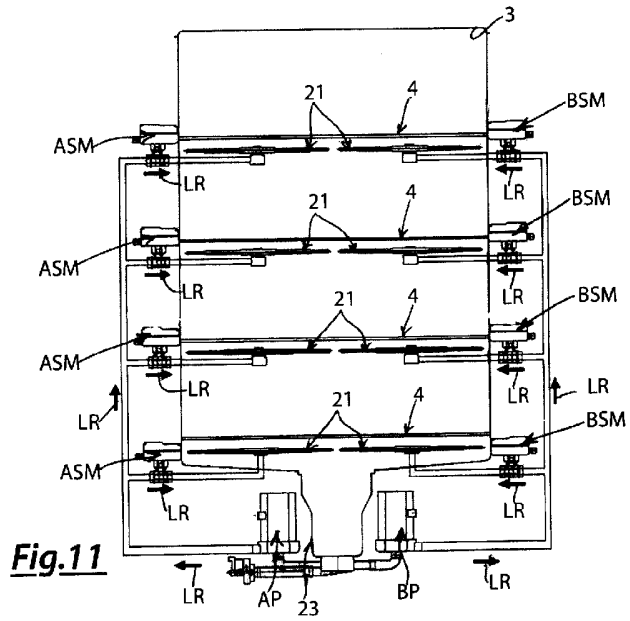




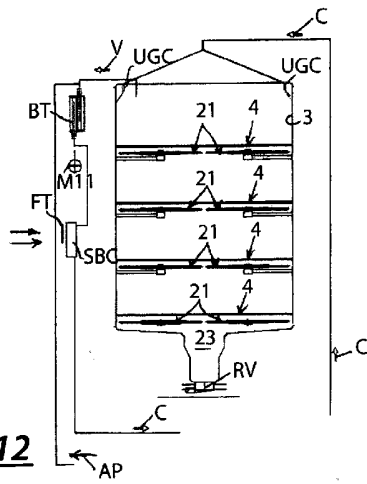
**Fig.9**



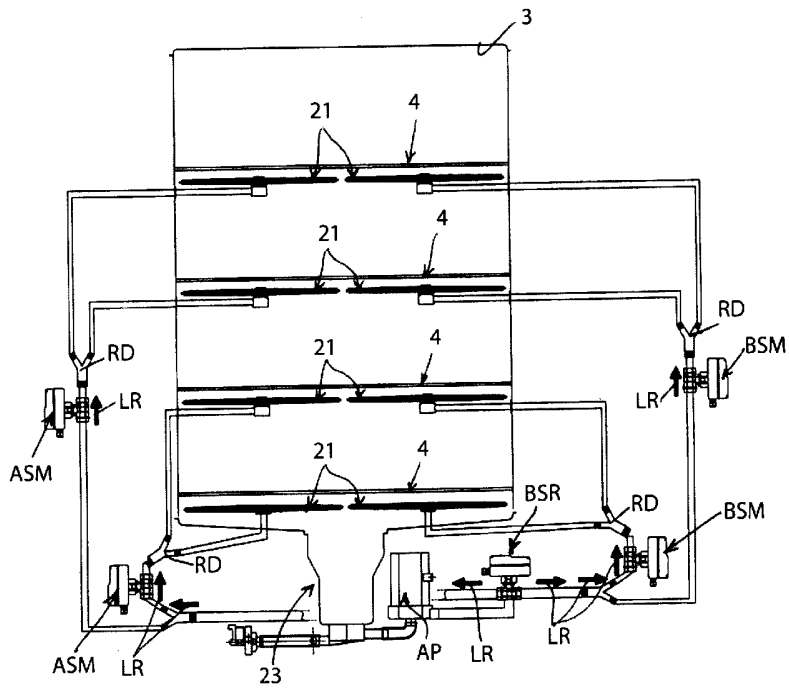
**Fig.10**



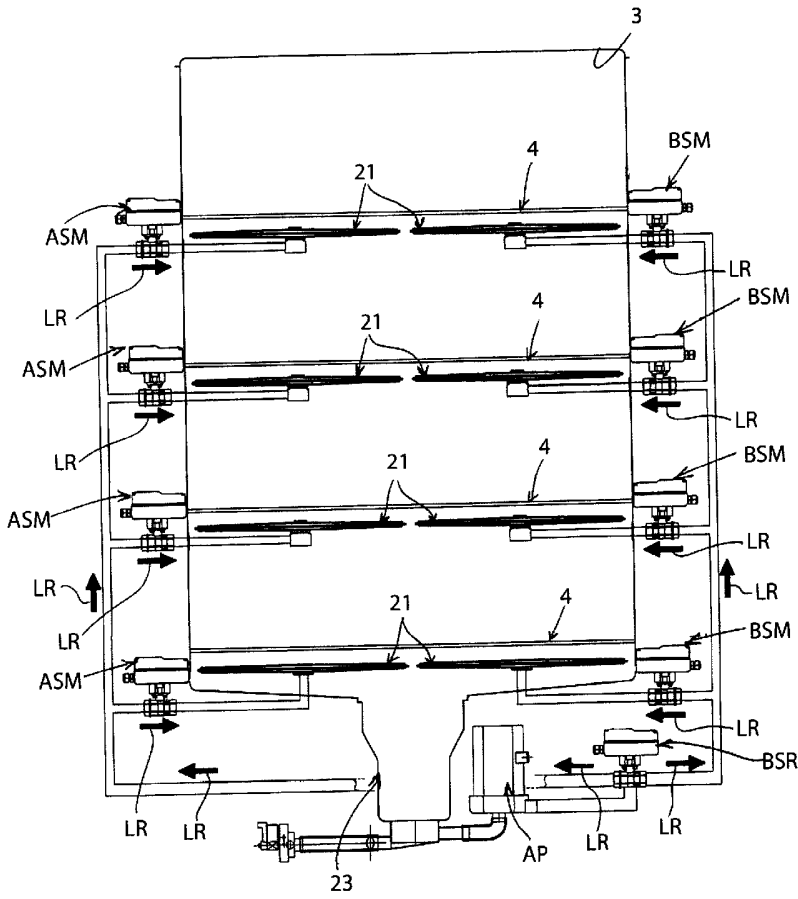
**Fig.11**



**Fig.12**



**Fig.13**



**Fig.14**