



US 20060071734A1

(19) **United States**

(12) **Patent Application Publication**
McCorquodale et al.

(10) **Pub. No.: US 2006/0071734 A1**

(43) **Pub. Date: Apr. 6, 2006**

(54) **FREQUENCY CONTROLLER FOR A MONOLITHIC CLOCK GENERATOR AND TIMING/FREQUENCY REFERENCE**

(60) Provisional application No. 60/555,193, filed on Mar. 22, 2004. Provisional application No. 60/555,193, filed on Mar. 22, 2004.

Publication Classification

(75) Inventors: **Michael Shannon McCorquodale**, Detroit, MI (US); **Scott Michael Pernia**, Pinckney, MI (US); **Sundus Kubba**, Saline, MI (US)

(51) **Int. Cl.**
H03L 1/00 (2006.01)
(52) **U.S. Cl.** **331/176**

(57) **ABSTRACT**

In various embodiments, the invention provides a frequency controller to control and provide a stable resonant frequency of a clock generator and/or a timing and frequency reference. Such stability is provided over variations in a selected parameter such as temperature and fabrication process variations. The various apparatus embodiments include a sensor adapted to provide a signal in response to at least one parameter of a plurality of parameters; and a frequency controller adapted to modify the resonant frequency in response to the second signal. In exemplary embodiments, the sensor is implemented as a current source responsive to temperature fluctuations, and the frequency controller is implemented as a plurality of controlled reactance modules which are selectively couplable to the resonator or to one or more control voltages. The controlled reactance modules may include fixed or variable capacitances or inductances, and may be binary weighted. Arrays of resistive modules are also provided, to generate one or more control voltages.

Correspondence Address:
GAMBURD LAW GROUP LLC
566 WEST ADAMS
SUITE 350
CHICAGO, IL 60661 (US)

(73) Assignee: **Mobius Microsystems, Inc.**, Detroit, MI

(21) Appl. No.: **11/232,407**

(22) Filed: **Sep. 20, 2005**

Related U.S. Application Data

(63) Continuation-in-part of application No. 11/084,962, filed on Mar. 21, 2005.
Continuation-in-part of application No. 11/085,372, filed on Mar. 21, 2005.

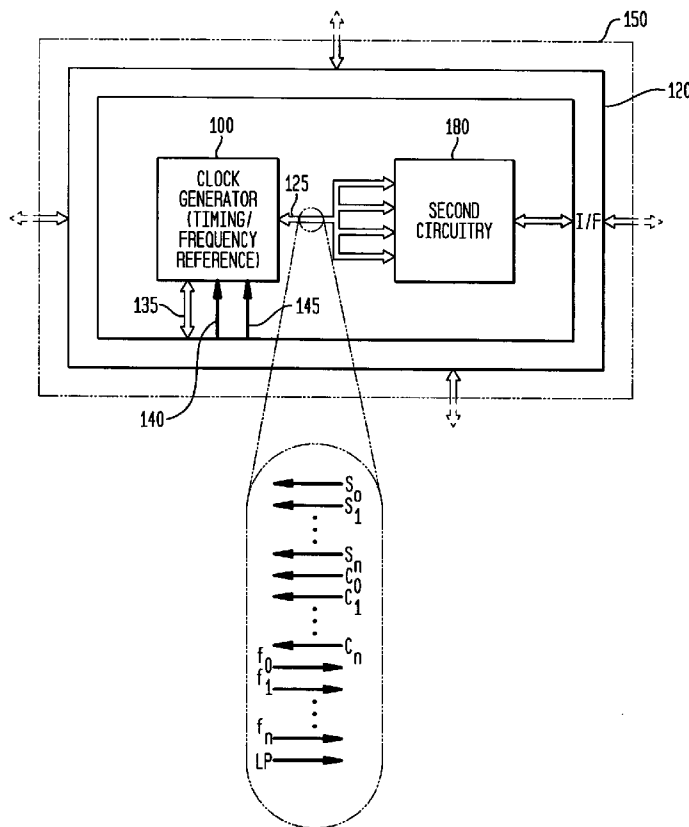

FIG. 1

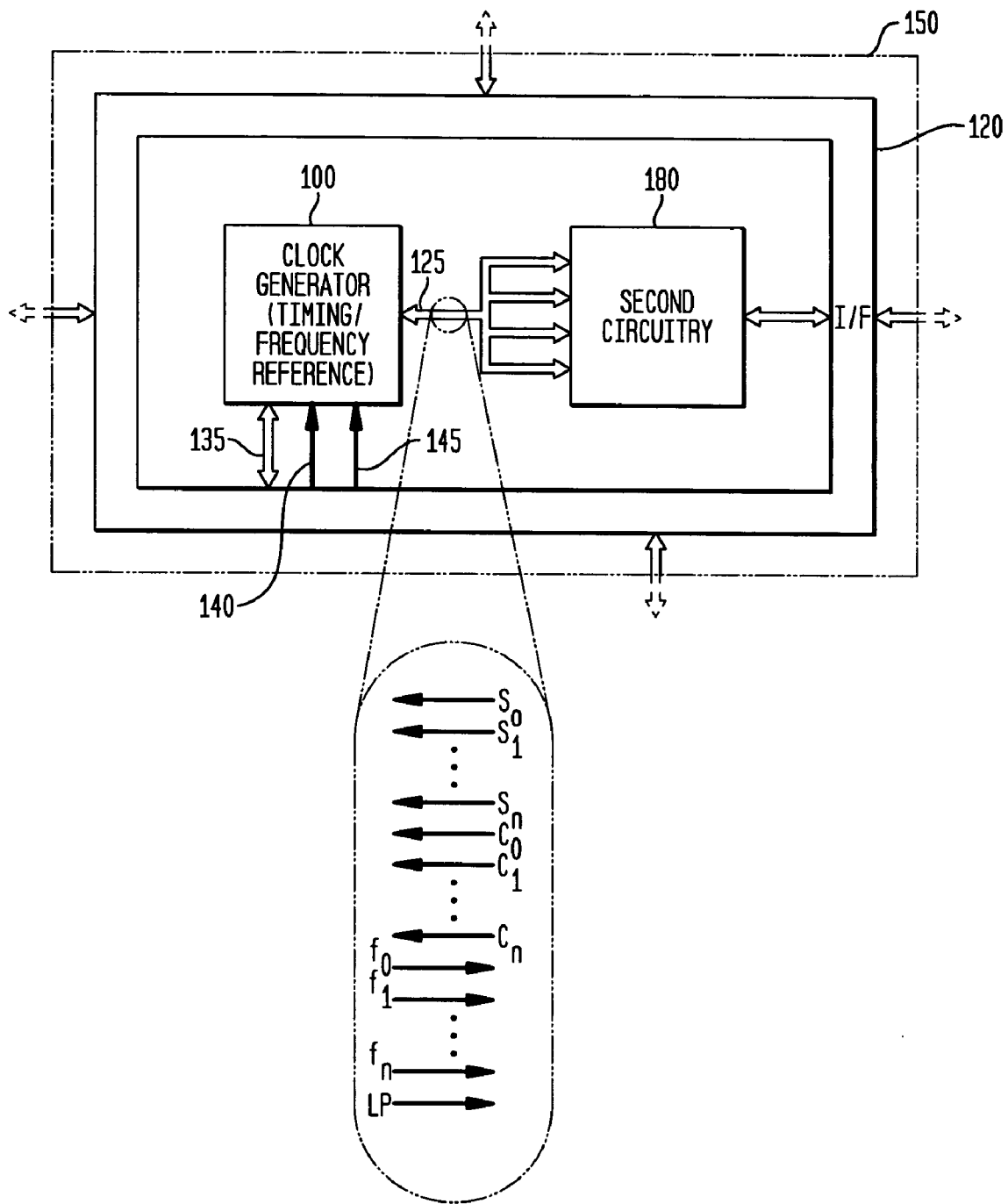
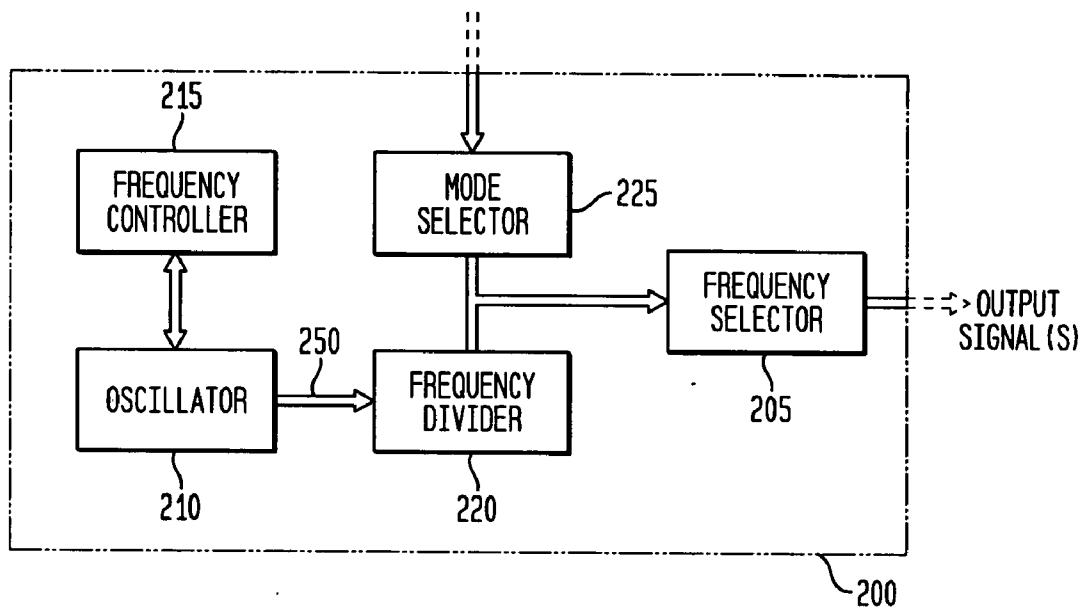

FIG. 2



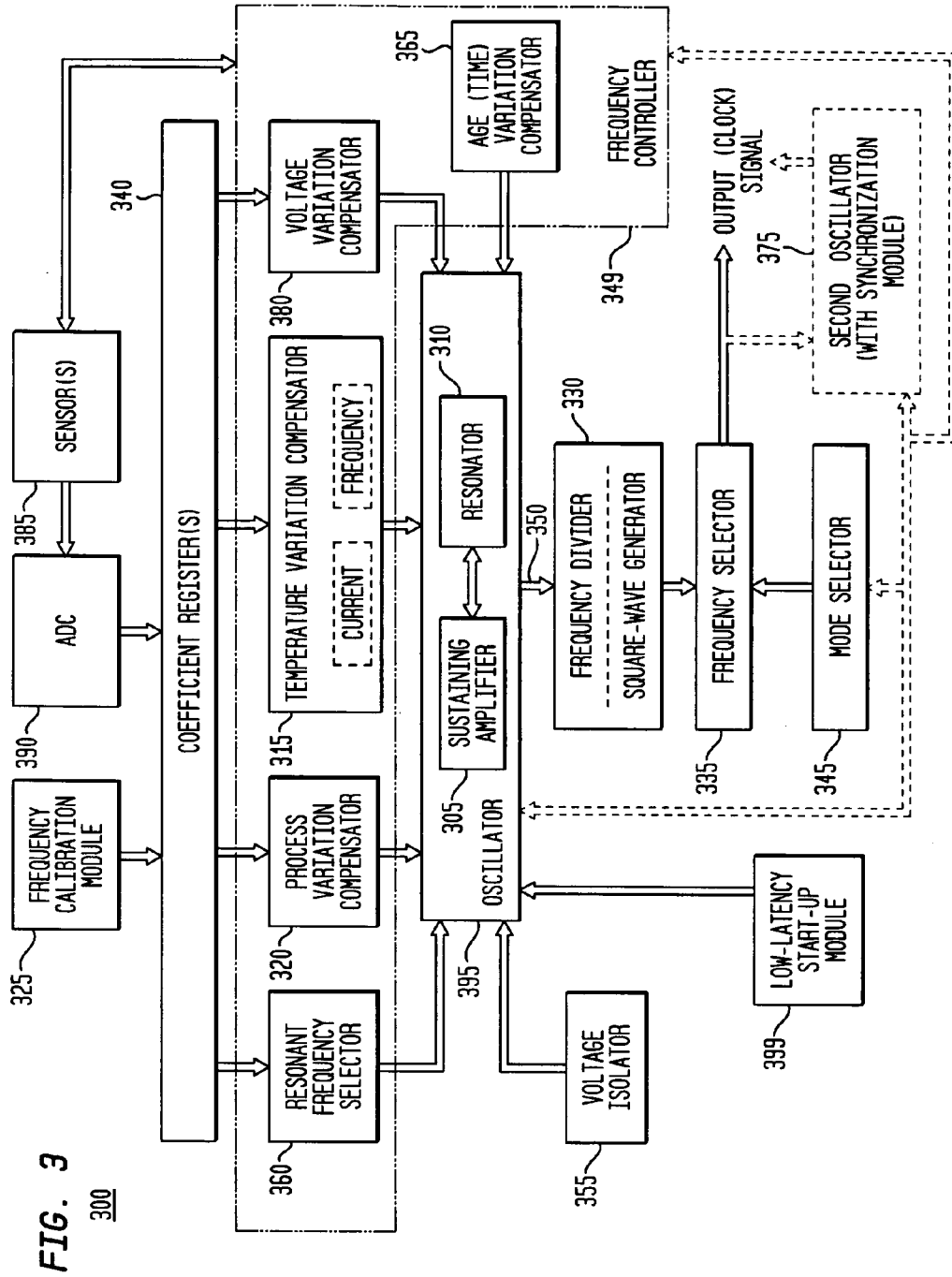

FIG. 4

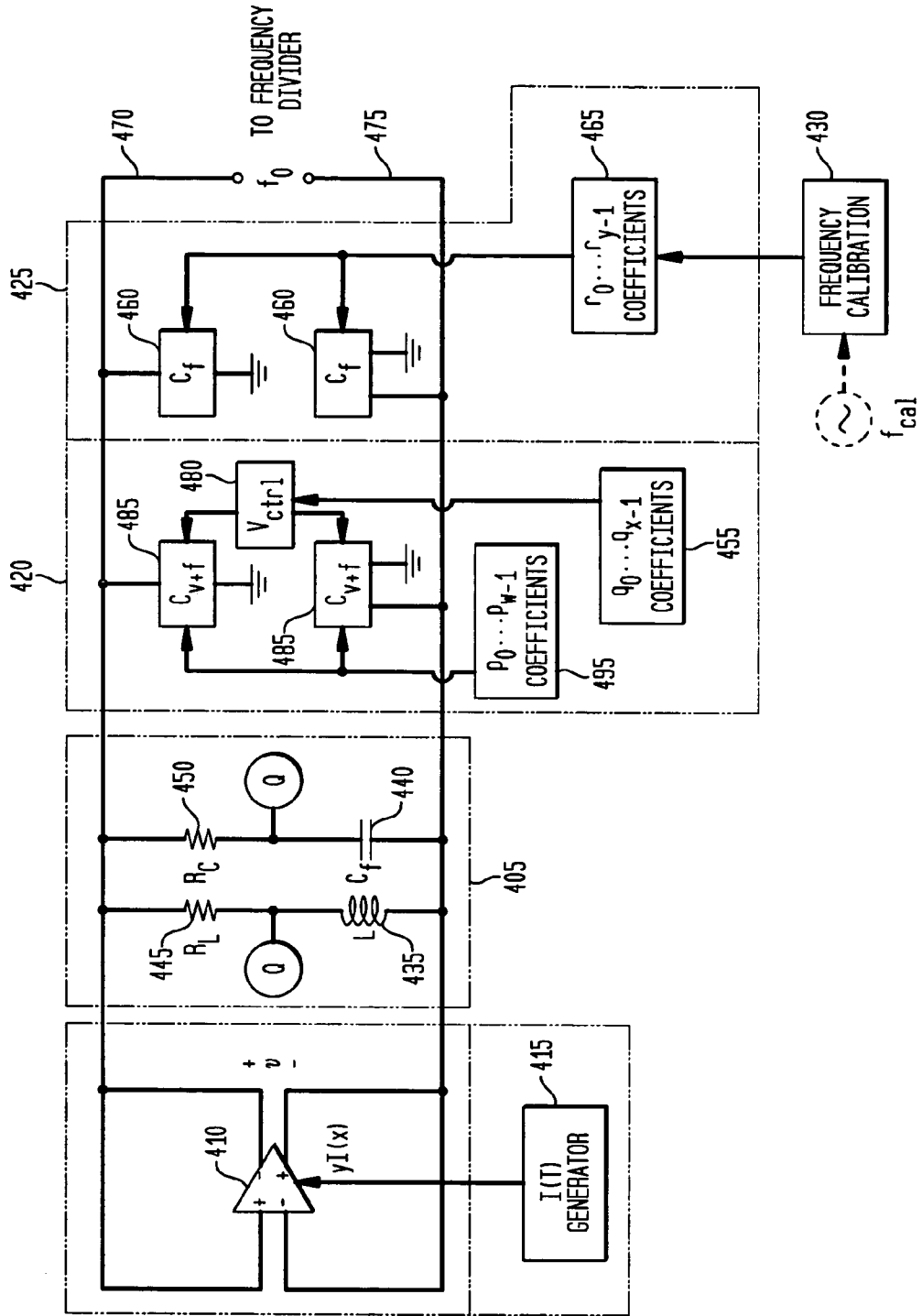

FIG. 5A

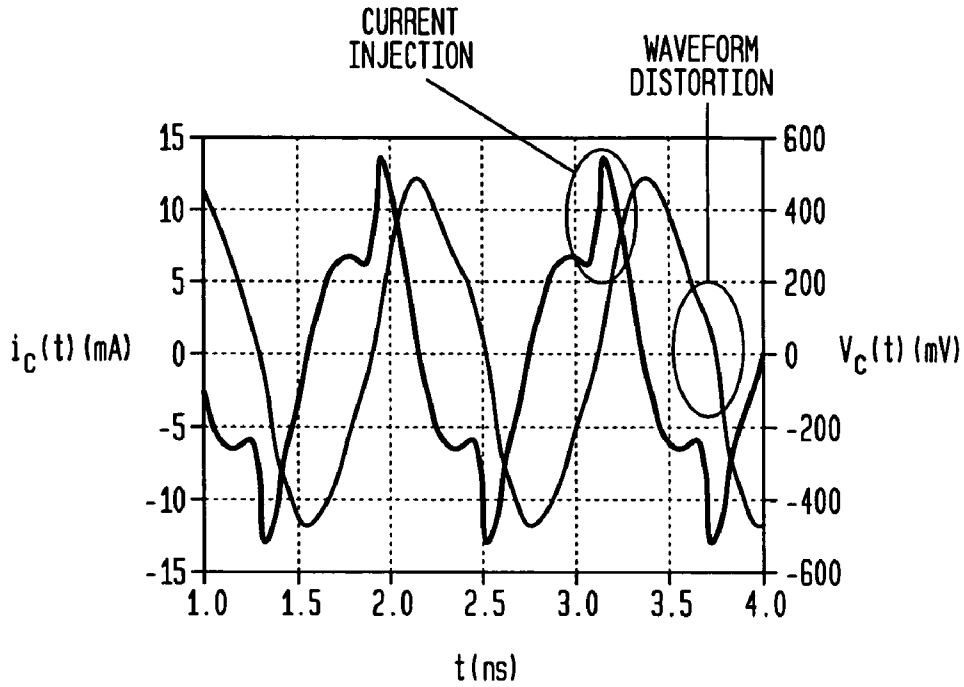
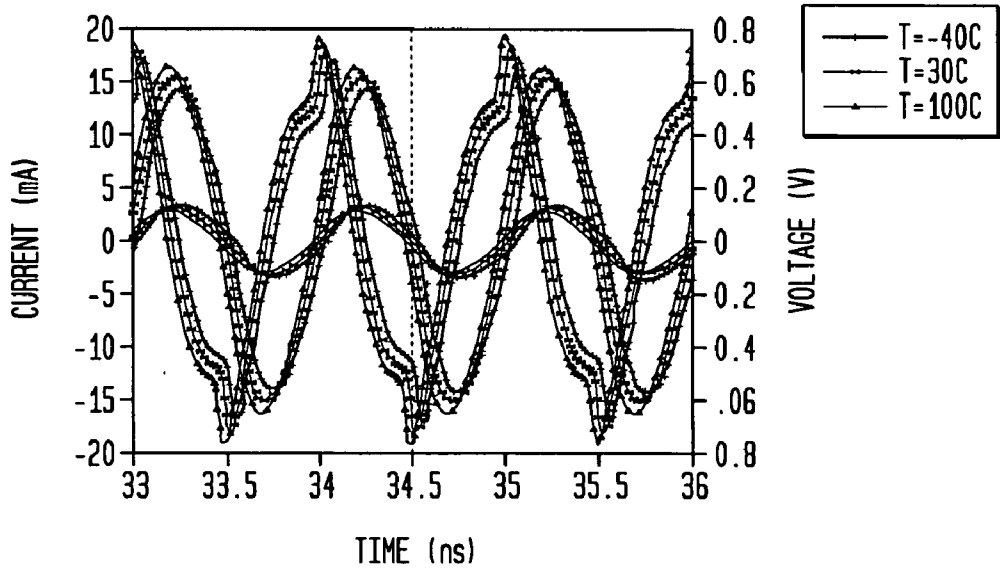

FIG. 5B



TEMPERATURE/BIAS DEPENDENCE

FIG. 5C

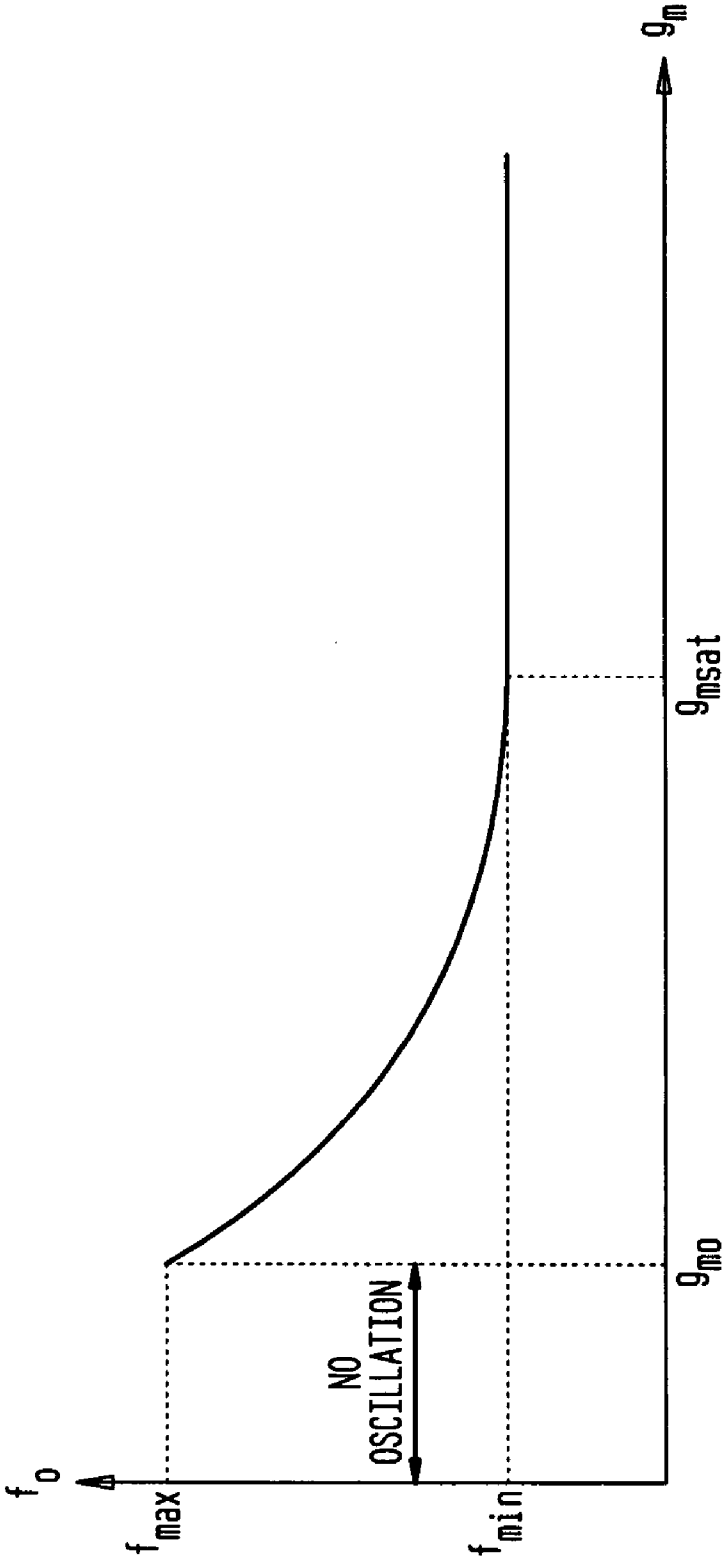

FIG. 6

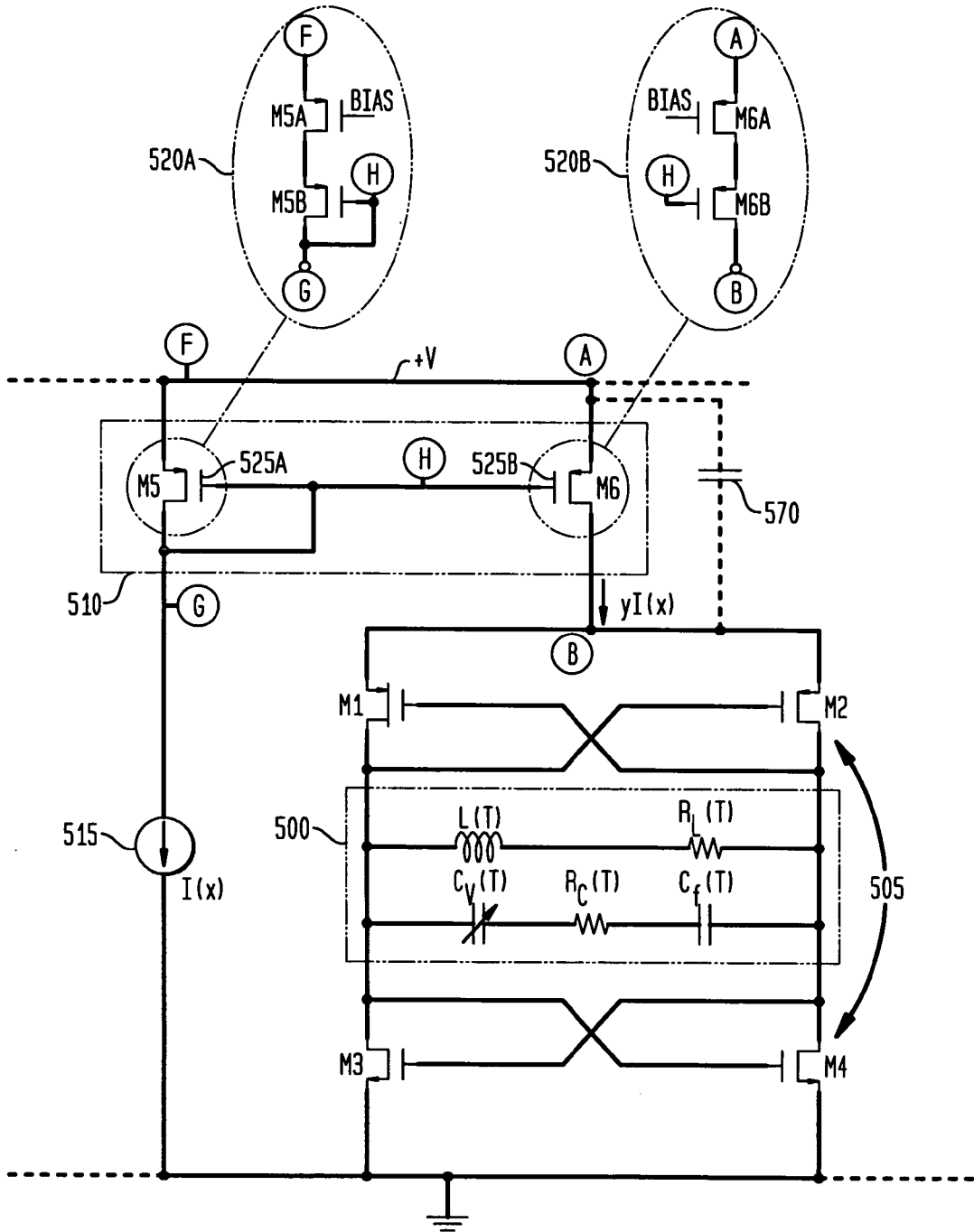

FIG. 7A

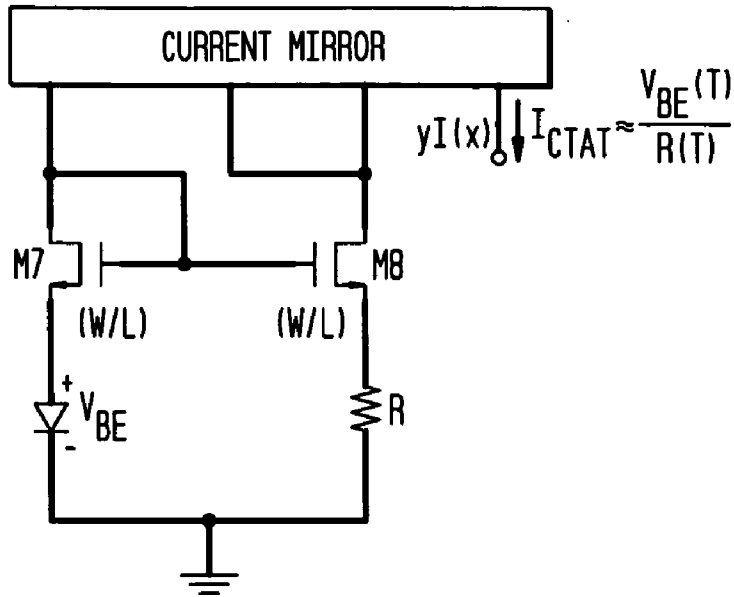

FIG. 7B

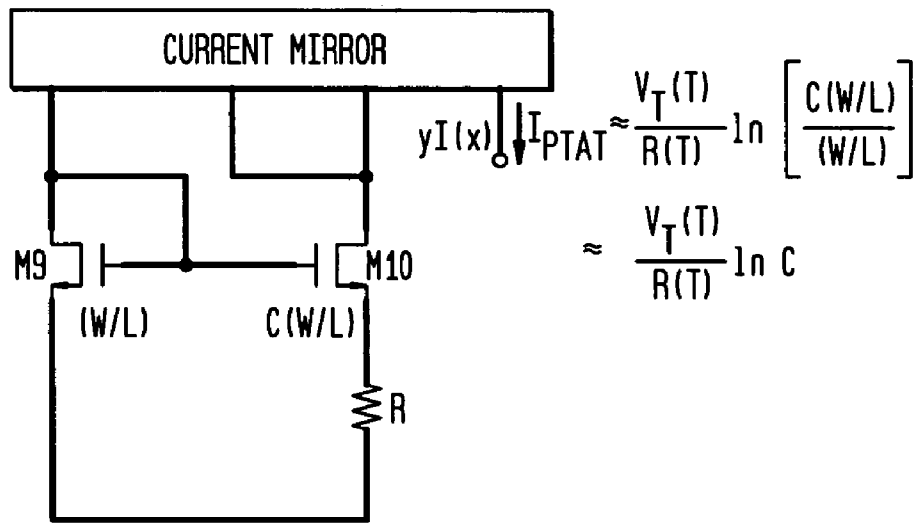

FIG. 7C

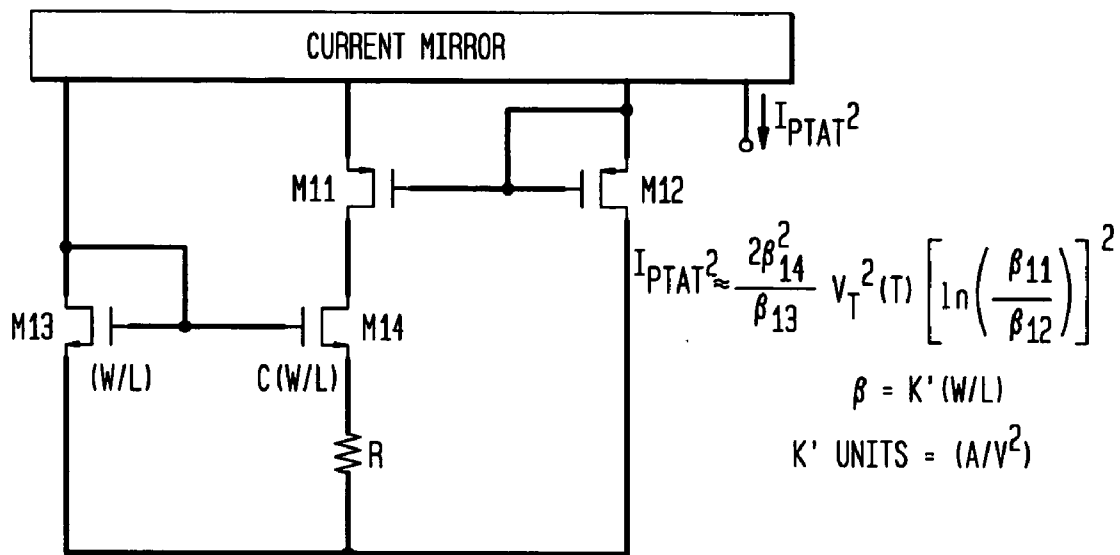

FIG. 7D

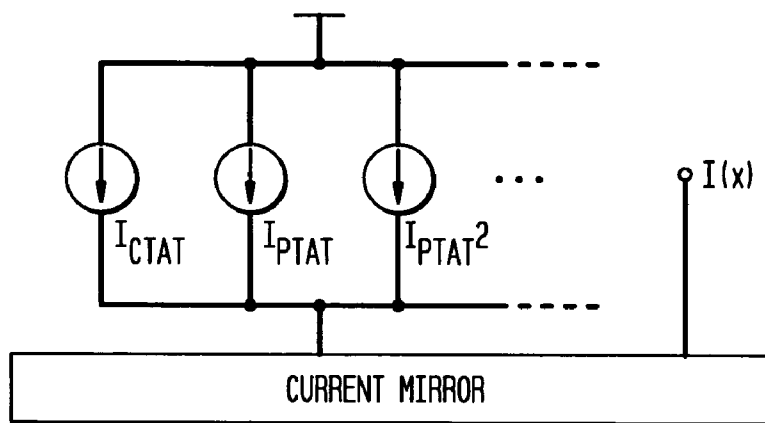

FIG. 8

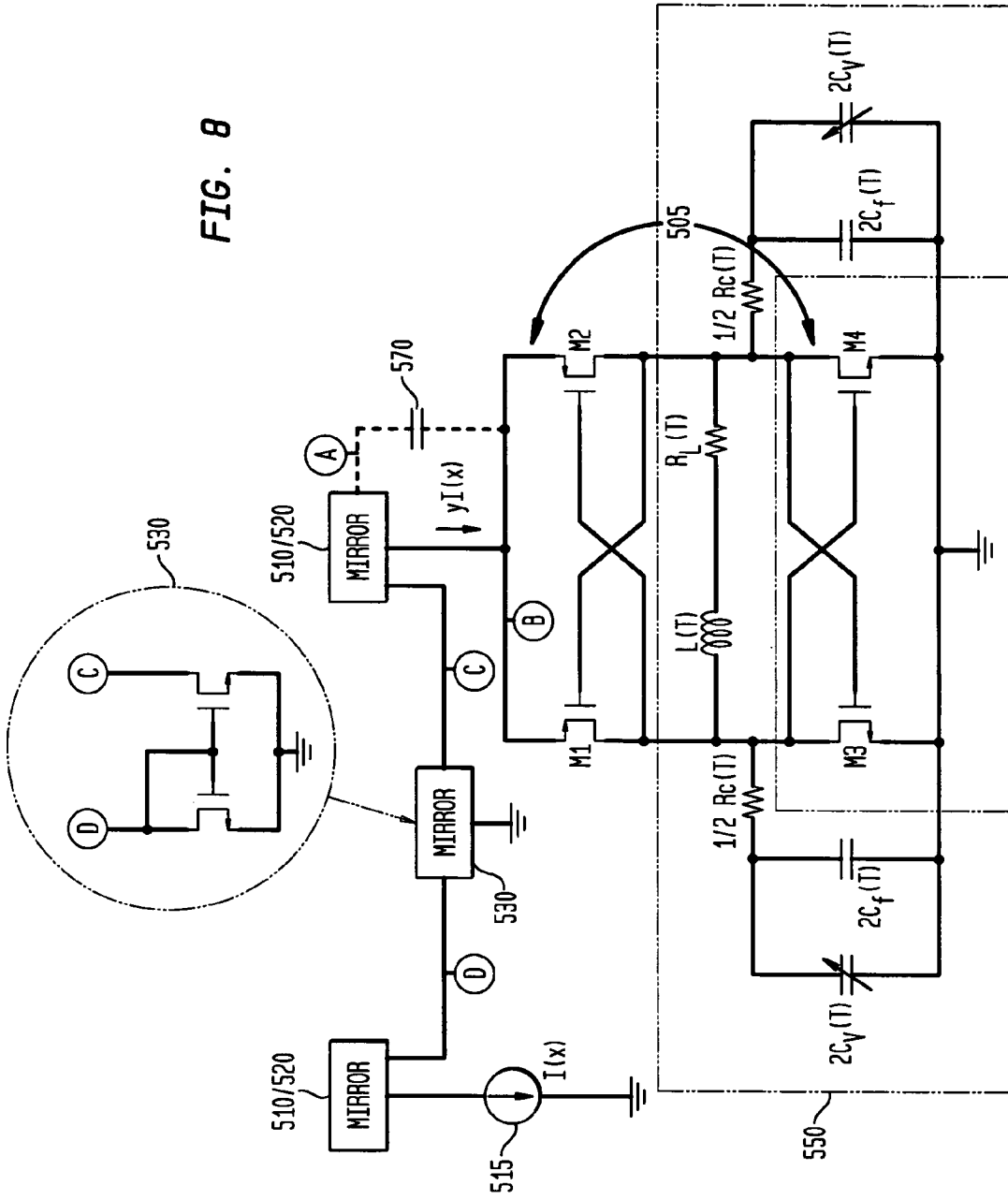

FIG. 9

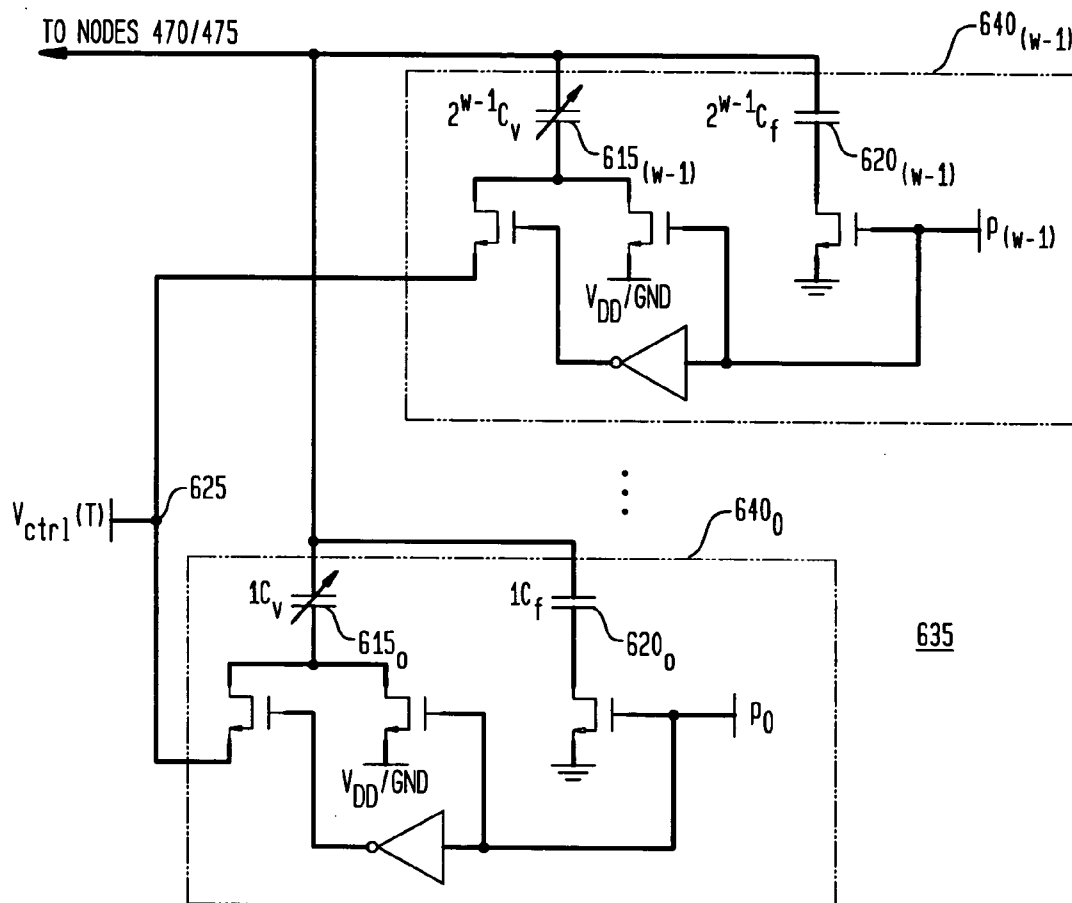

FIG. 10

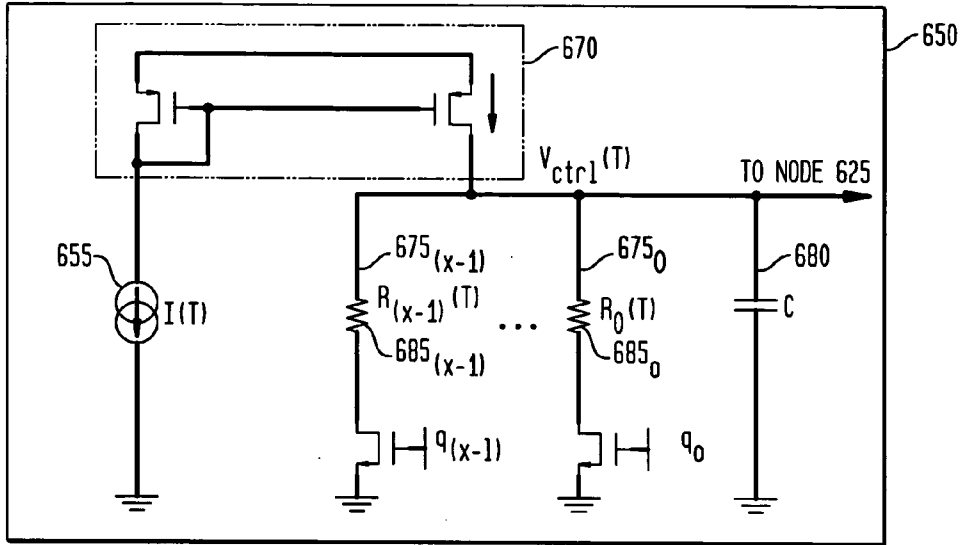

FIG. 11

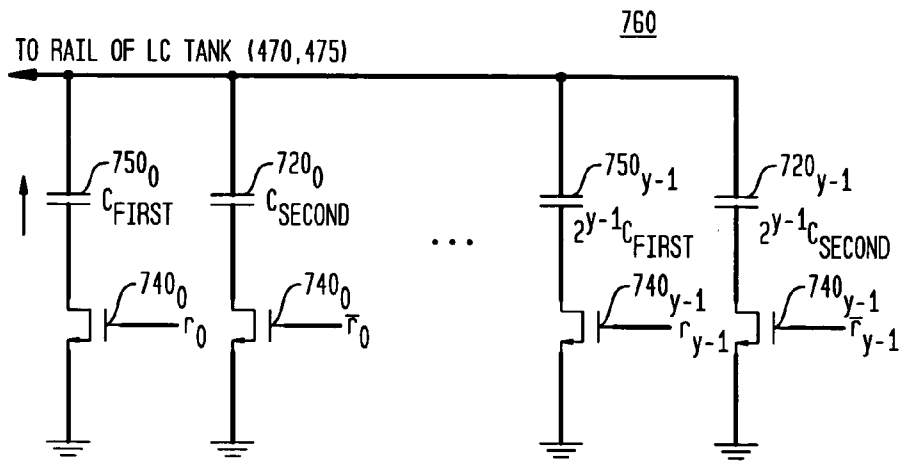

FIG. 12

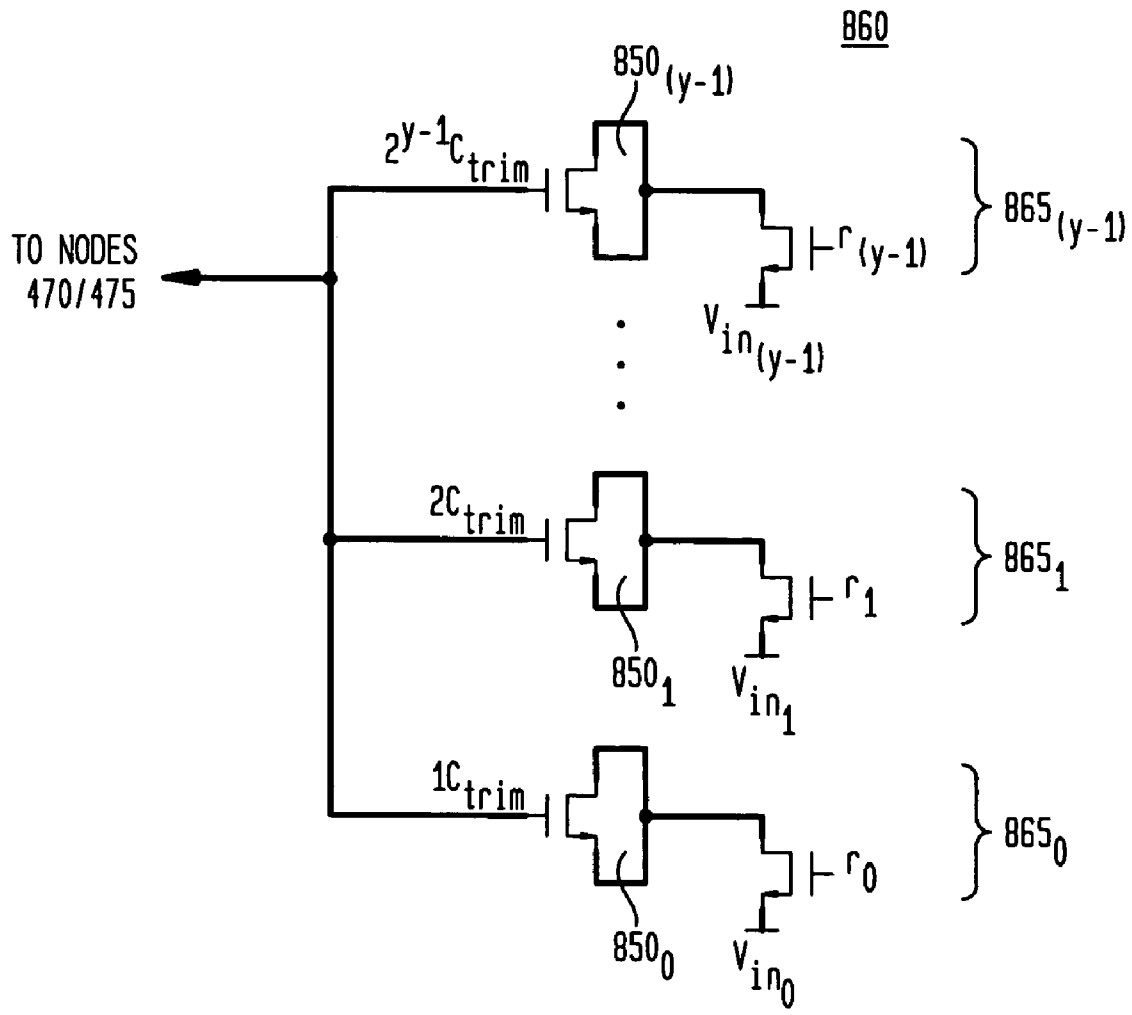

FIG. 13

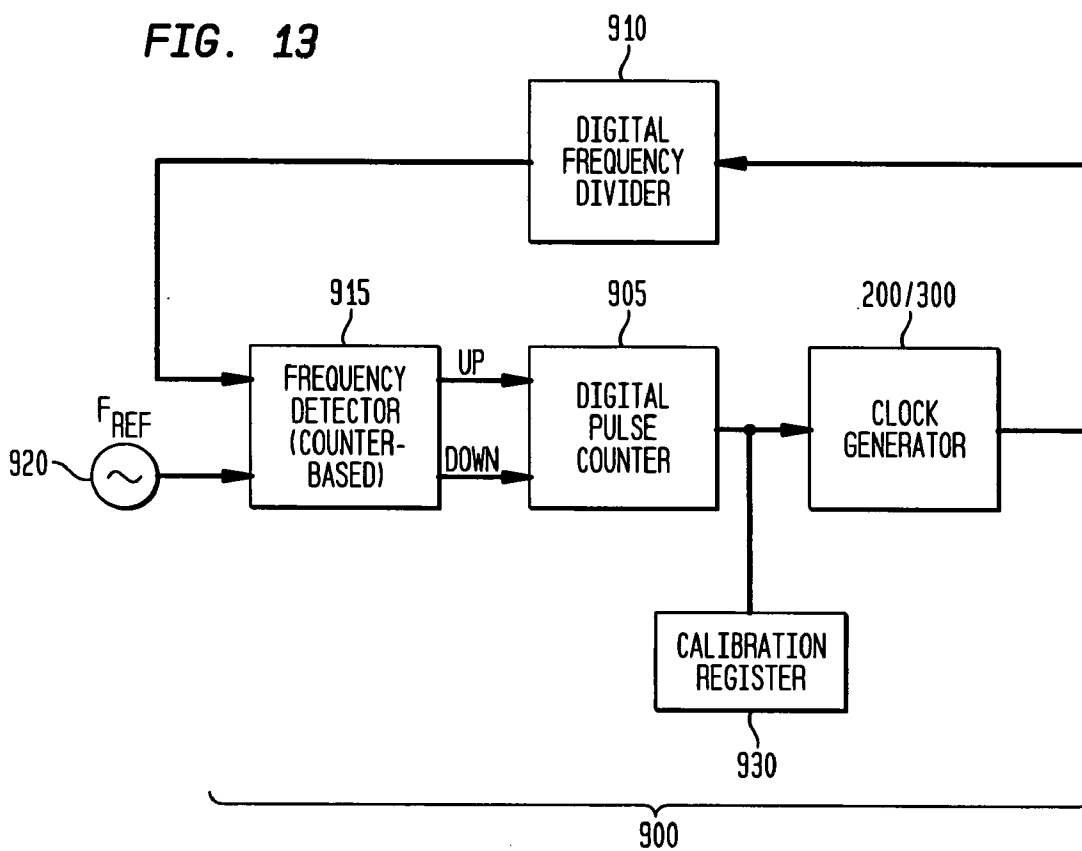

FIG. 14

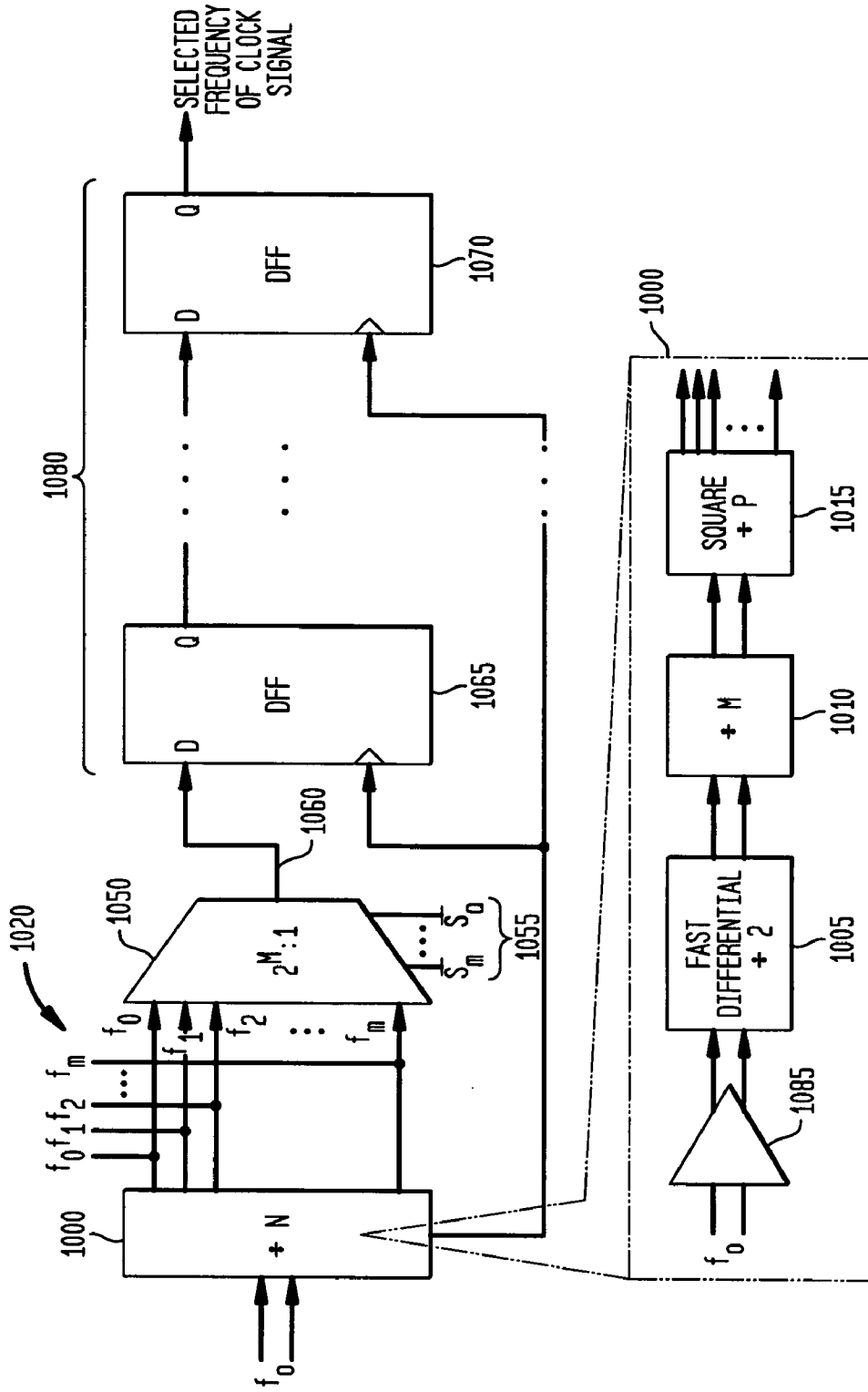

FIG. 15B

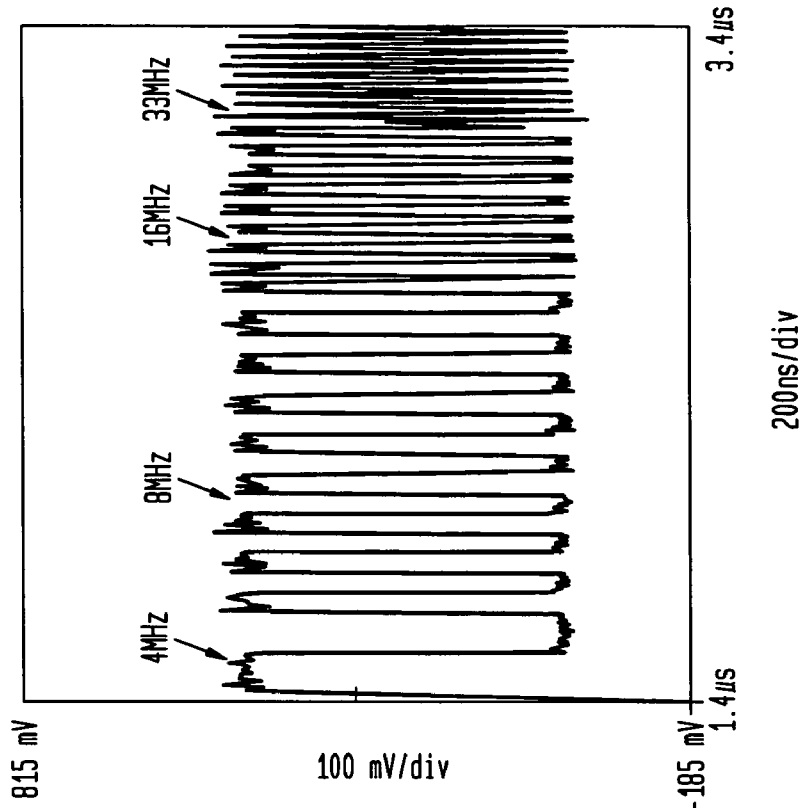

FIG. 15A

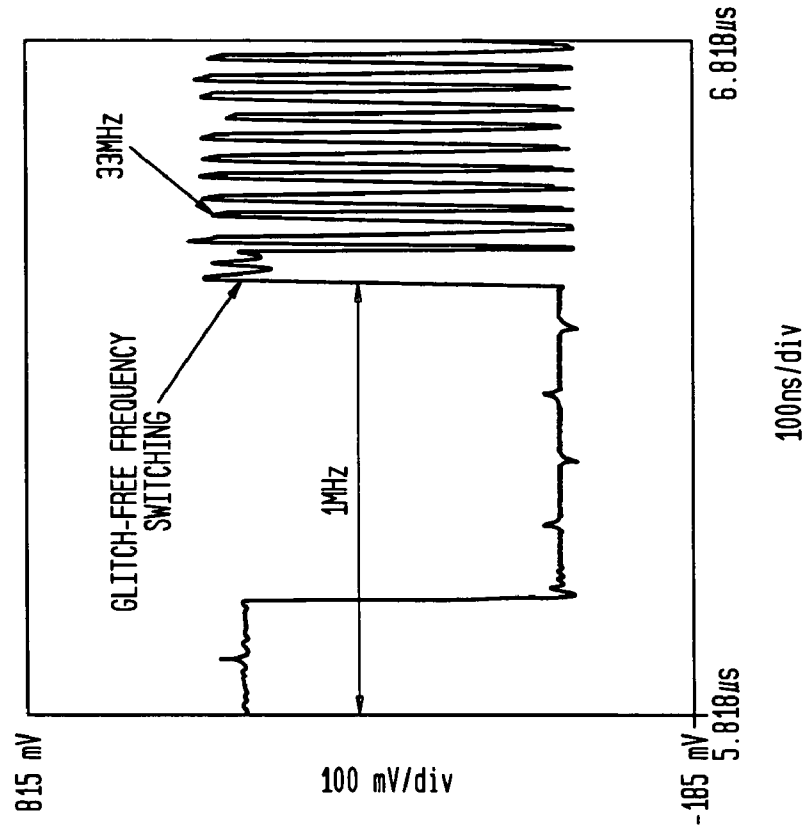

FIG. 16

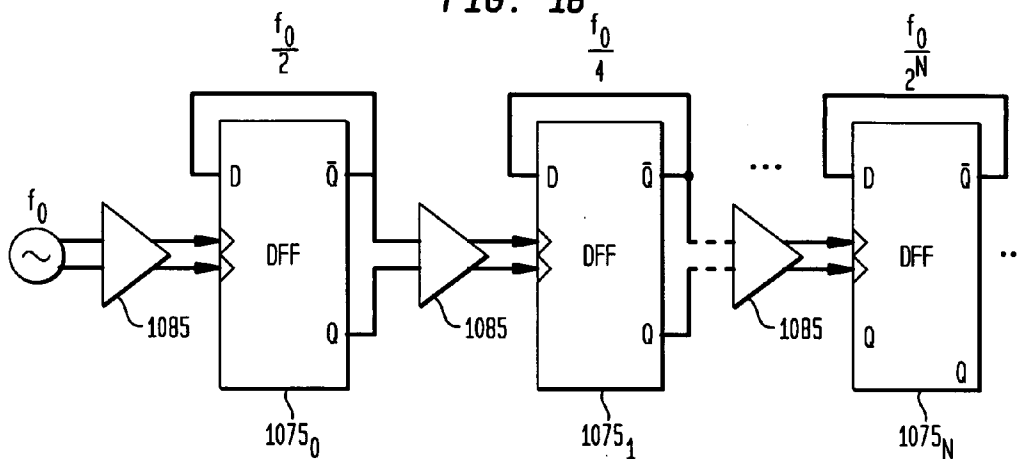

FIG. 17

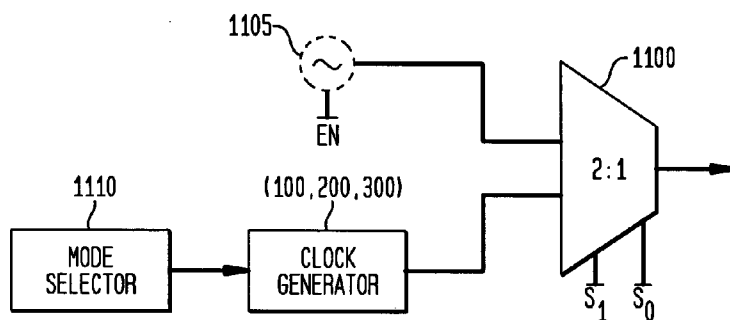

FIG. 18

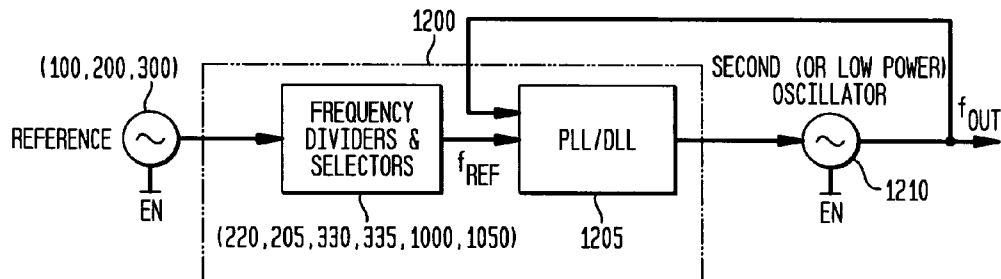

FIG. 19

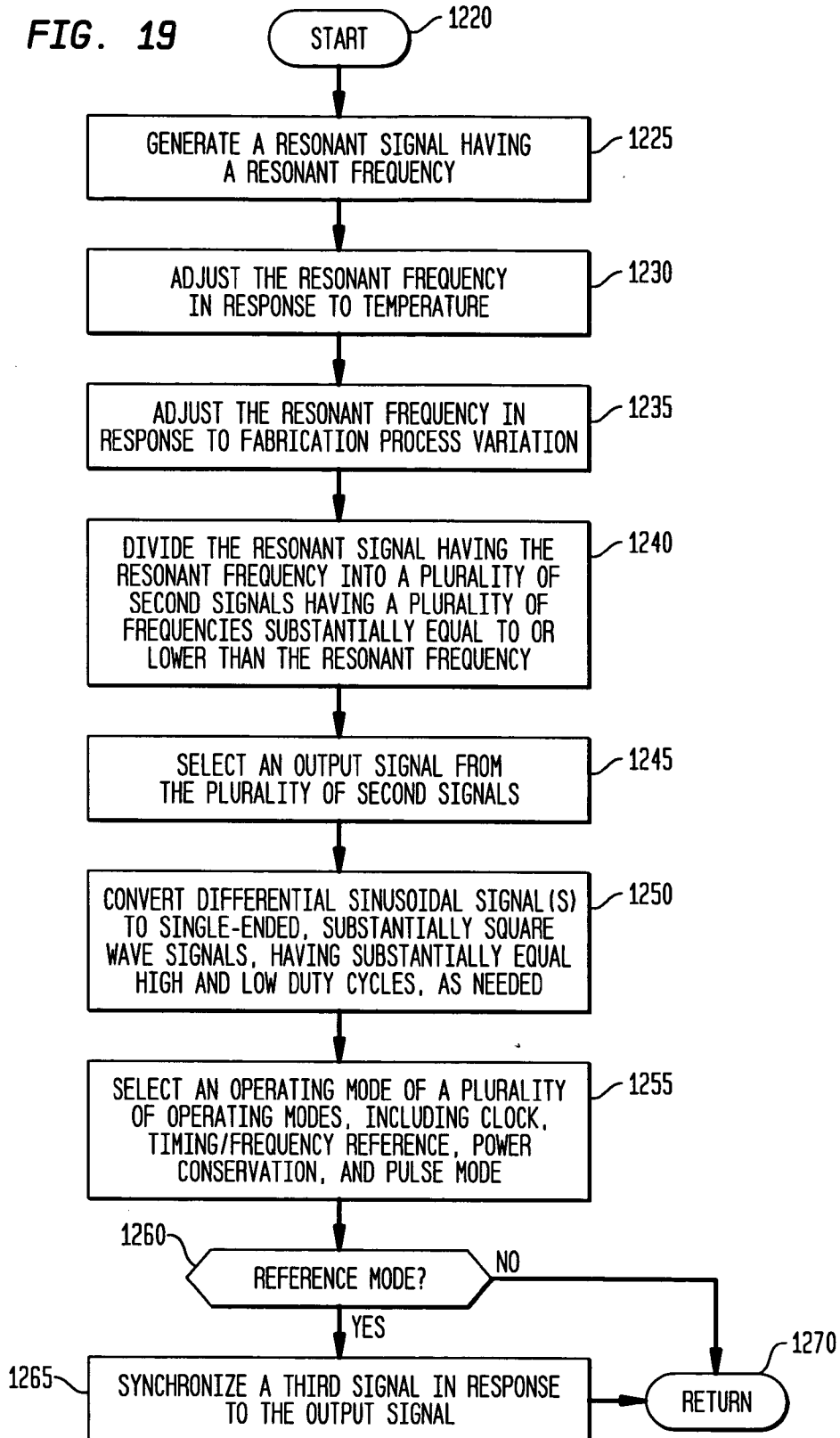

FIG. 20

1300

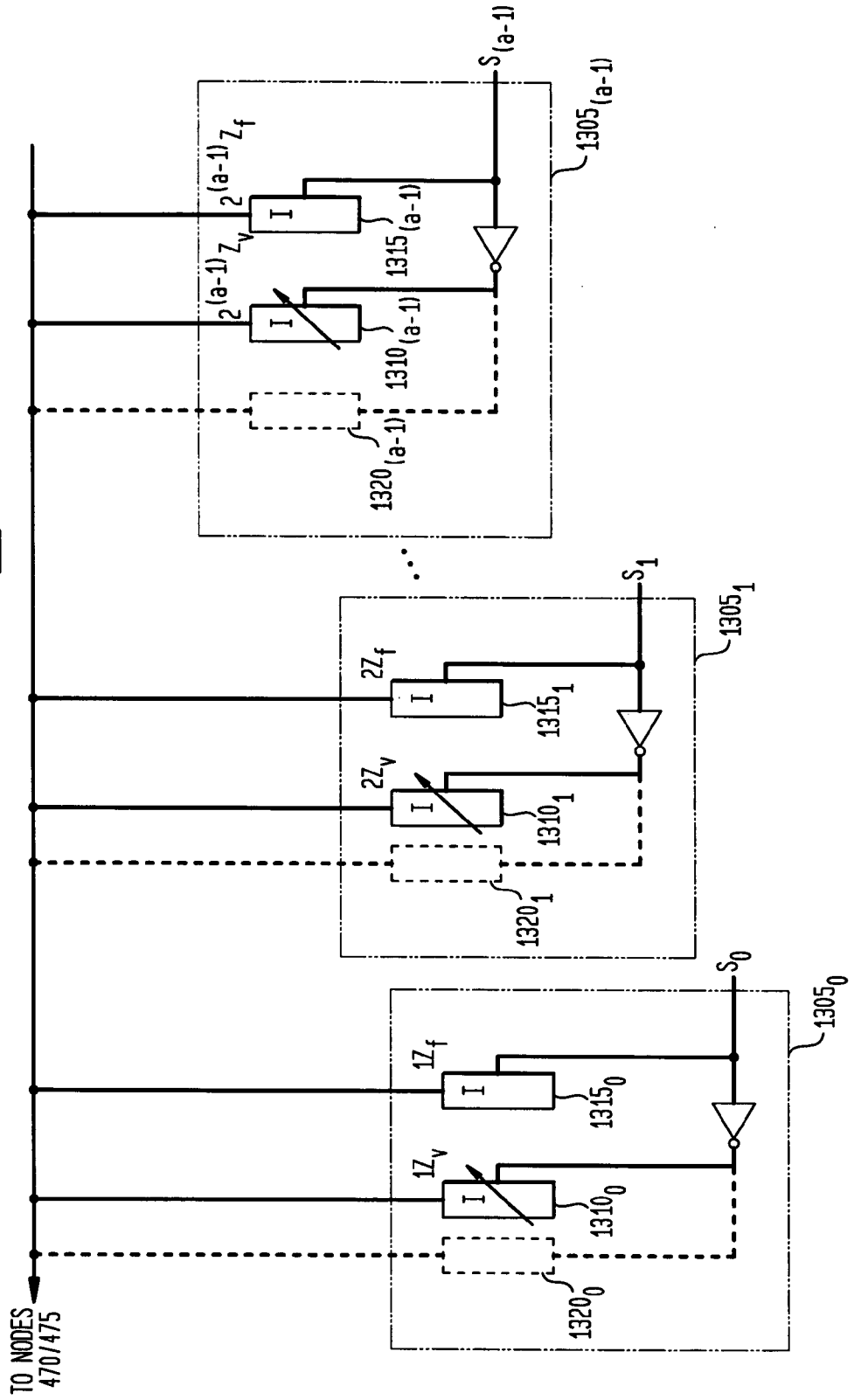

FIG. 21

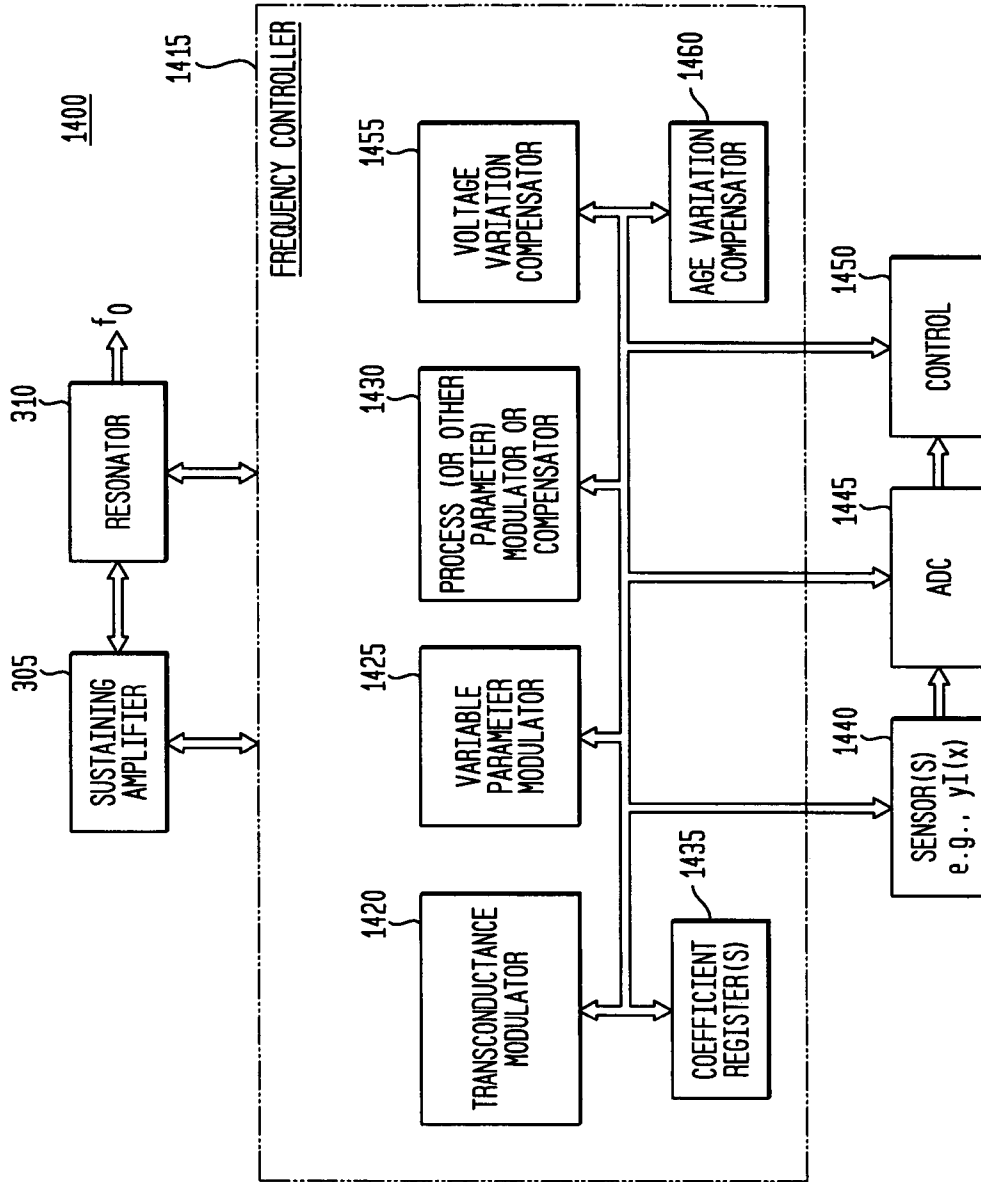

FIG. 22

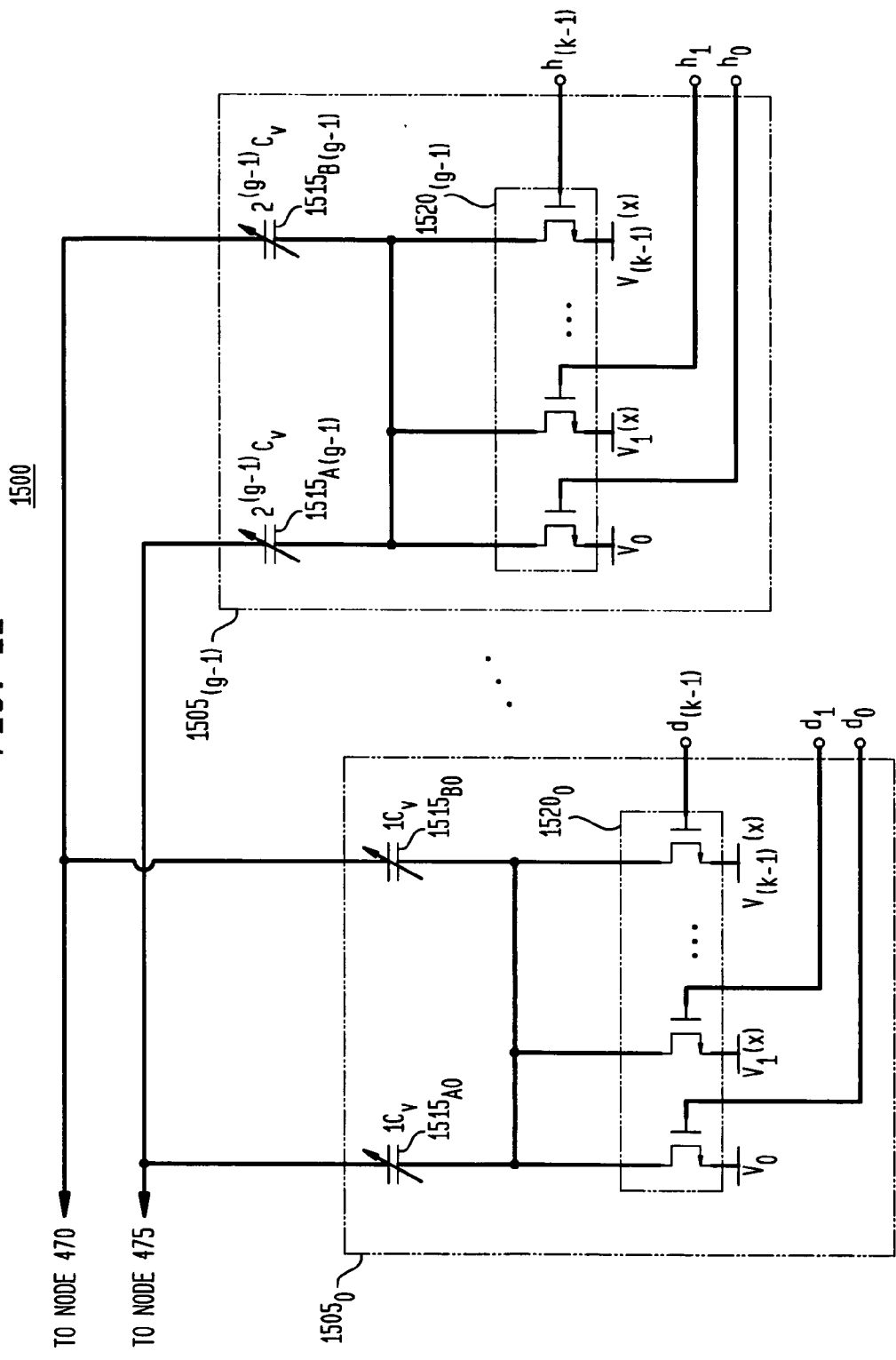

FIG. 23

1600

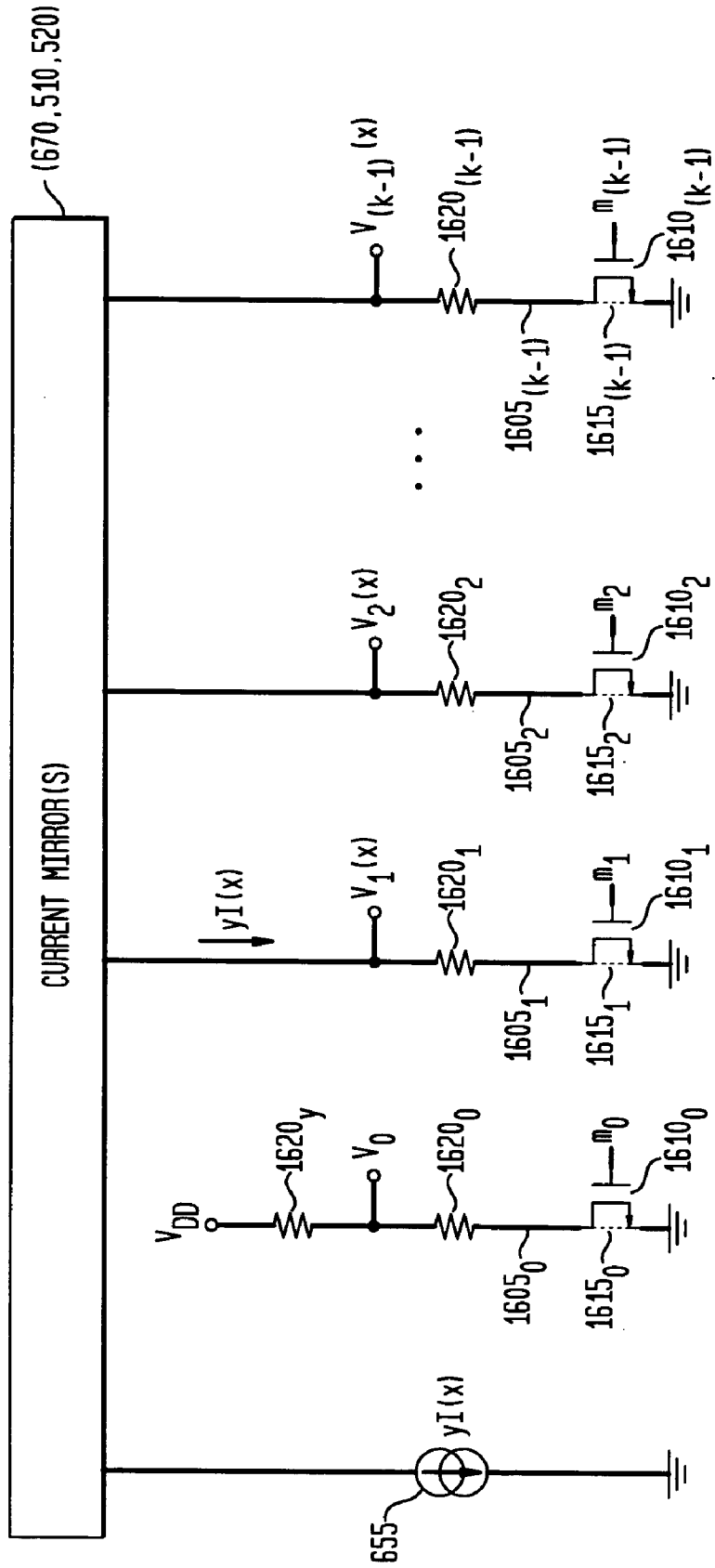

FIG. 24

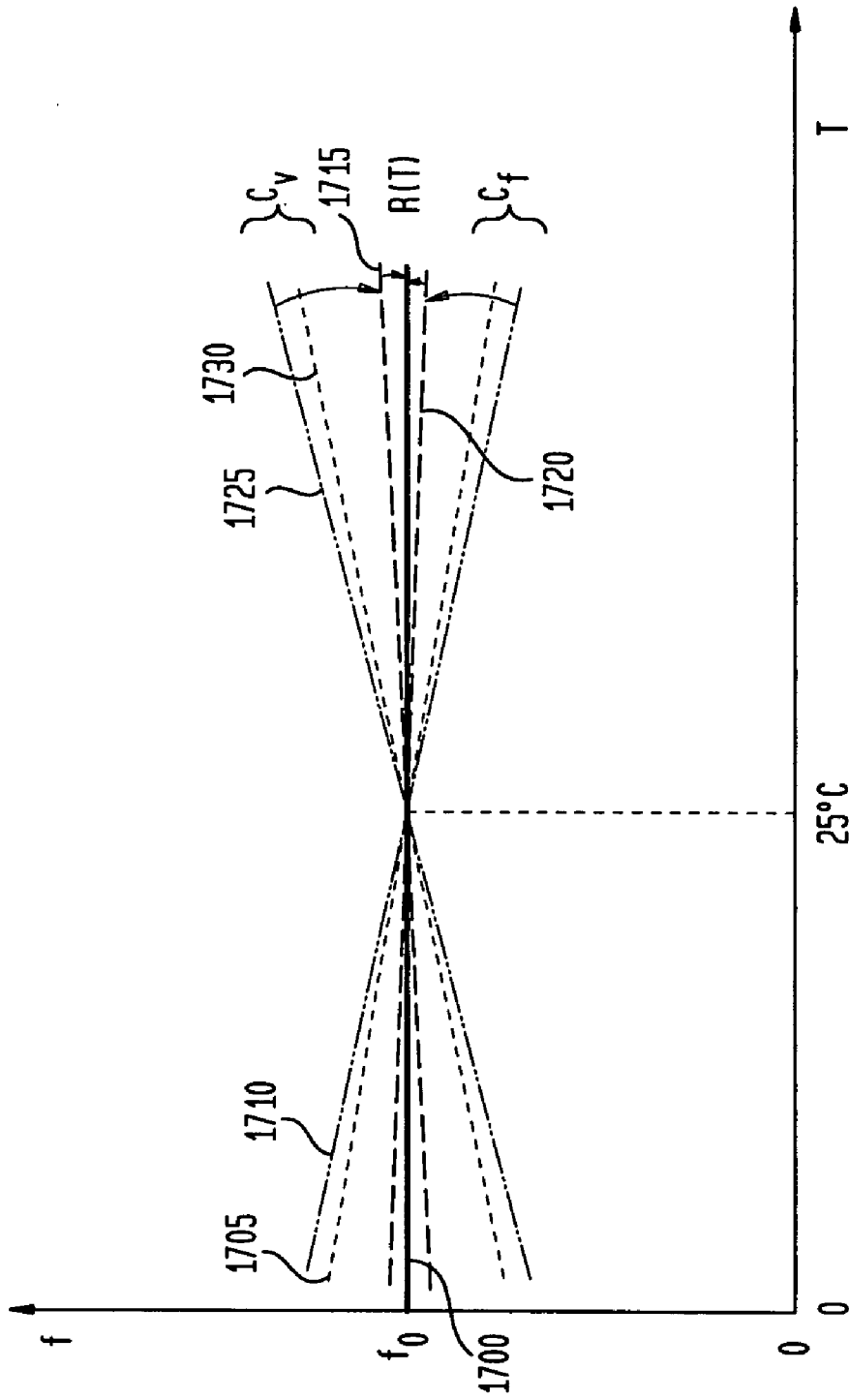

FIG. 25

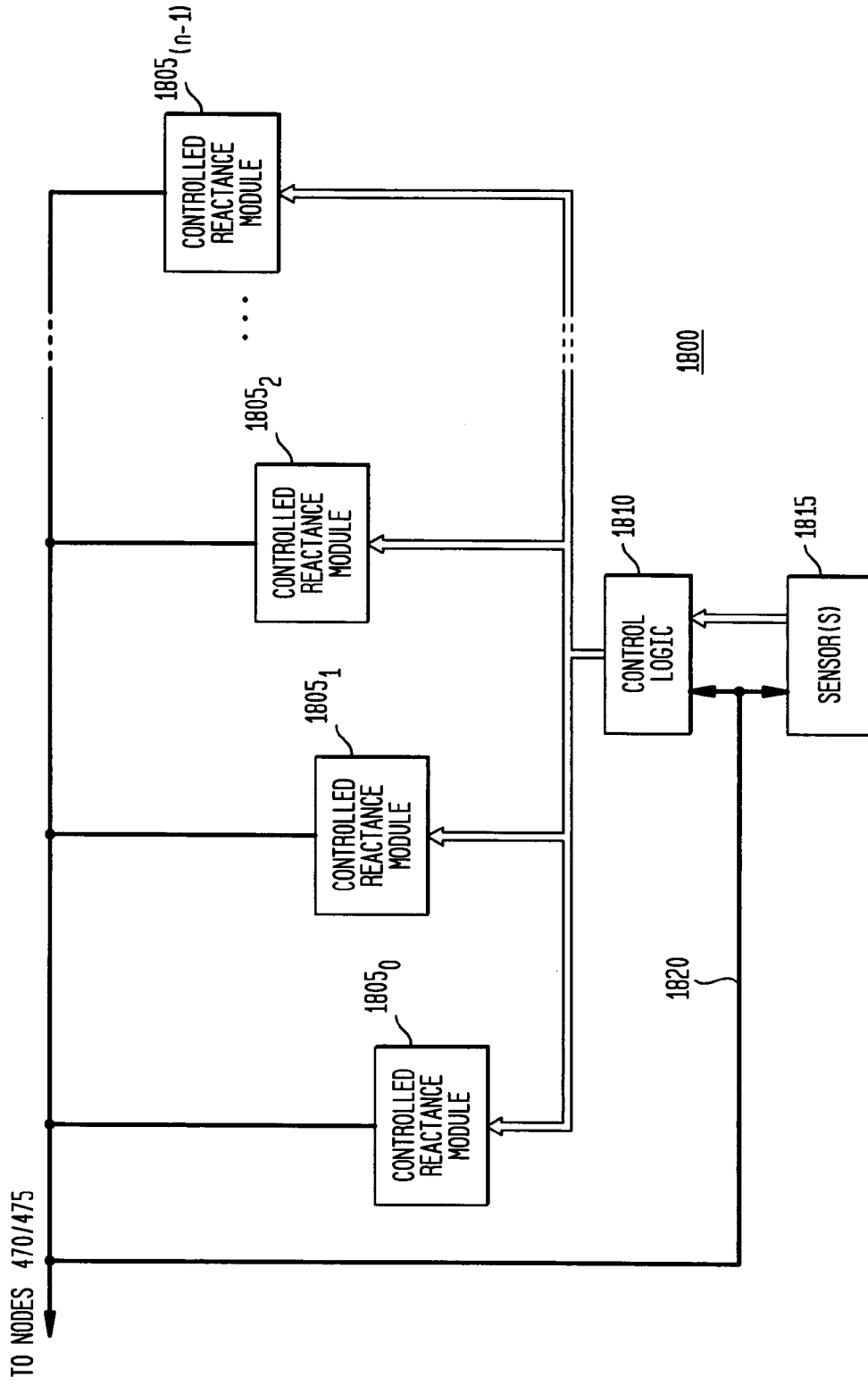

FIG. 26

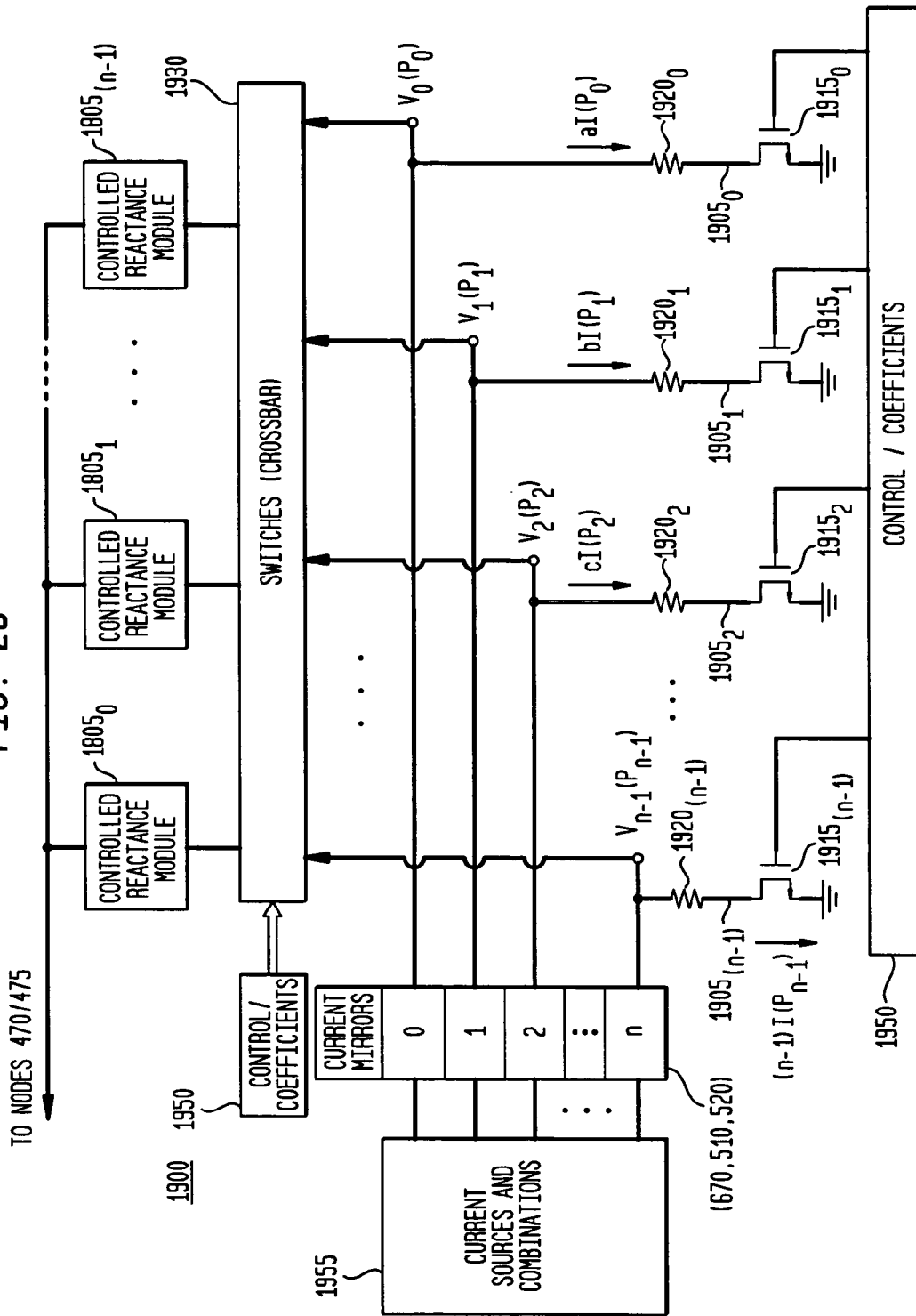

FIG. 27

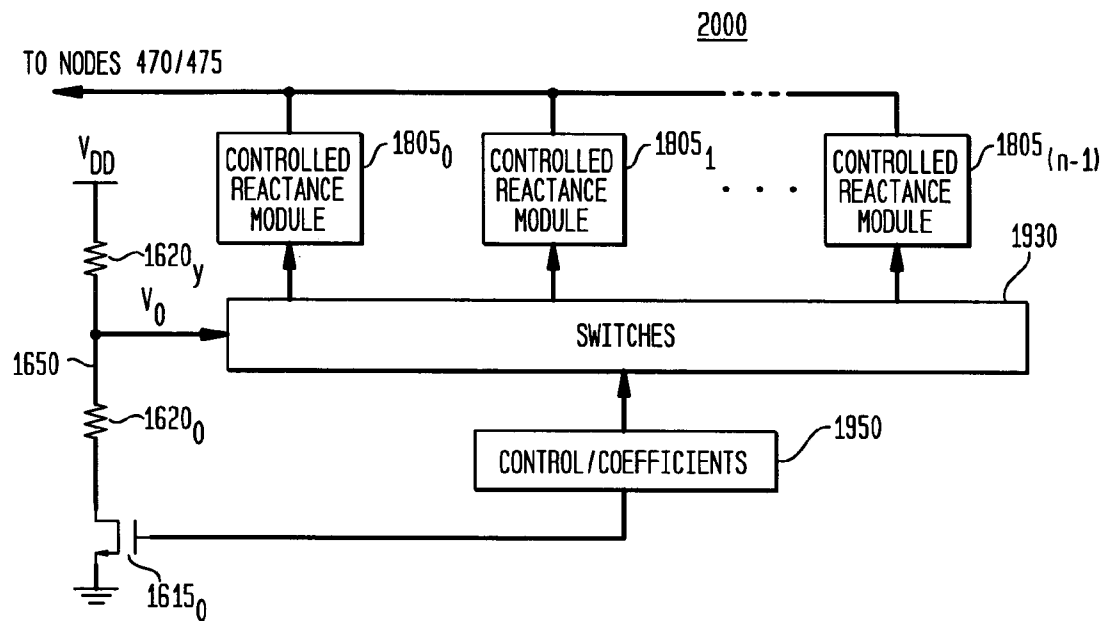

FIG. 28

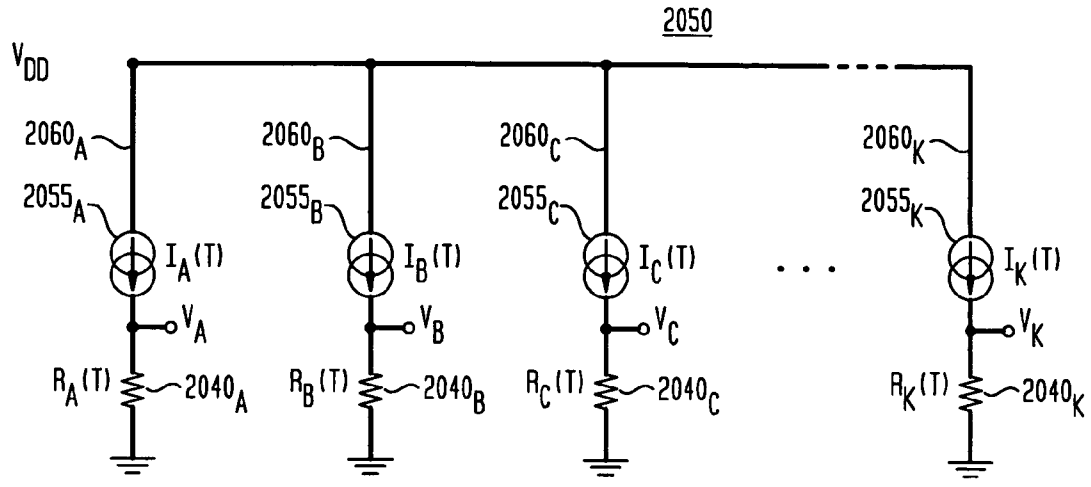

FIG. 29

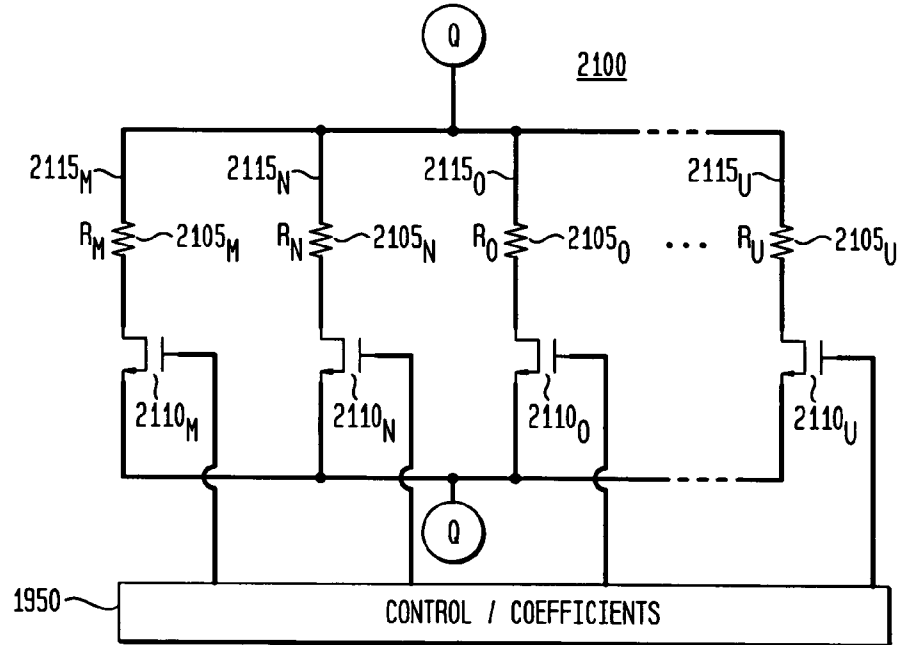
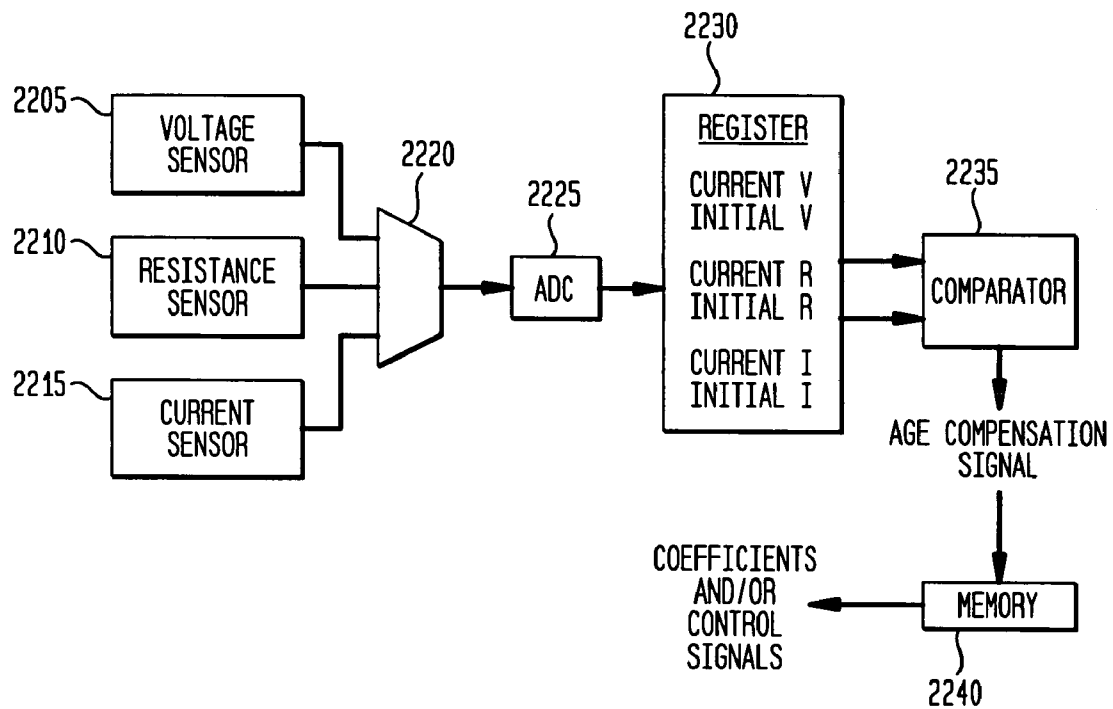

FIG. 30

2200



FREQUENCY CONTROLLER FOR A MONOLITHIC CLOCK GENERATOR AND TIMING/FREQUENCY REFERENCE

CROSS-REFERENCE TO RELATED APPLICATIONS

[0001] This application is a continuation-in-part of and claims priority to U.S. patent application Ser. No. 11/084, 962, filed Mar. 21, 2005, inventors Michael Shannon McCorquodale, Scott Michael Pemia, and Amar Sarbbaseh Basu, entitled "Monolithic Clock Generator and Timing/Frequency Reference" (the "first related application"), which is commonly assigned herewith, the contents of which are incorporated herein by reference, and with priority claimed for all commonly disclosed subject matter, and further claims priority to U.S. Provisional Patent Application Ser. No. 60/555,193, filed Mar. 22, 2004, inventor Michael Shannon McCorquodale, entitled "Monolithic and Top-Down Clock Synthesis with Micromachined Radio Frequency Reference" (the "second related application"), which is commonly assigned herewith, the contents of which are incorporated herein by reference, and with priority claimed for all commonly disclosed subject matter.

[0002] This application is also related to and claims priority to U.S. patent application Ser. No. 11/085,372, filed Mar. 21, 2005, inventors Michael Shannon McCorquodale and Scott Michael Pemia, entitled "Transconductance and Current Modulation for Resonant Frequency Control and Selection" (the "third related application"), which is commonly assigned herewith, the contents of which are incorporated herein by reference, and with priority claimed for all commonly disclosed subject matter, and further claims priority to the second related application.

FIELD OF THE INVENTION

[0003] The present invention, in general, relates to oscillation or clocking signal generation, and more particularly, relates to a frequency controller for a clock signal generator and timing/frequency reference to provide frequency control in response to variation in ambient or operating temperature or variation in other parameters such as voltage, frequency, age, and fabrication process.

BACKGROUND OF THE INVENTION

[0004] Accurate clock generators or timing references have generally relied upon crystal oscillators, such as quartz oscillators, which provide a mechanical, resonant vibration at a particular frequency. The difficulty with such crystal oscillators is that they cannot be fabricated as part of the same integrated circuit ("IC") that is to be driven by their clock signal. For example, microprocessors such as the Intel Pentium processor require a separate clock IC. As a consequence, virtually every circuit requiring an accurate clock signal requires an off-chip clock generator.

[0005] There are several consequences for such non-integrated solutions. For example, because such a processor must be connected through outside circuitry (such as on a printed circuit board (PCB)), power dissipation is comparatively increased. In applications which rely on a finite power supply, such as battery power in mobile communications, such additional power dissipation is detrimental.

[0006] In addition, such non-integrated solutions, by requiring an additional IC, increase space and area requirements, whether on the PCB or within the finished product, which is also detrimental in mobile environments. Moreover, such additional components increase manufacturing and production costs, as an additional IC must be fabricated and assembled with the primary circuitry (such as a micro-processor).

[0007] Other clock generators which have been produced as integrated circuits with other circuits are generally not sufficiently accurate, particularly over fabrication process, voltage, and temperature ("PVT") variations. For example, ring, relaxation and phase shift oscillators may provide a clock signal suitable for some low-sensitivity applications, but have been incapable of providing the higher accuracy required in more sophisticated electronics, such as in applications requiring significant processing capability or data communications. In addition, these clock generators or oscillators often exhibit considerable frequency drift, jitter, have a comparatively low Q-value, and are subject to other distortions from noise and other interference.

[0008] As a consequence, a need remains for a clock generator or timing reference which may be integrated monolithically with other circuitry, as a single IC, and which is highly accurate over PVT variations. Such a clock generator or timing reference should be free-running and self-referencing, and should not require locking or referencing to another reference signal. Such a clock generator or timing reference should exhibit minimal frequency drift and have comparatively low jitter, and should be suitable for applications requiring a highly accurate system clock. Such a clock generator or timing reference should also provide multiple operating modes, including a clock mode, a reference mode, a power conservation mode, and a pulsed mode. Lastly, such a clock generator or timing reference should provide for control over output frequency, to provide a stable and desired frequency in response to variation in ambient or junction temperature or variation in other parameters such as voltage, fabrication process, frequency, and age.

SUMMARY OF THE INVENTION

[0009] In various exemplary embodiments, the invention provides a frequency controller and a temperature compensator for use in providing open-loop frequency control and selection for a low-jitter, free-running and self-referencing clock generator and/or a timing and frequency reference which is highly accurate over PVT and aging (time) variations and which can be integrated monolithically with other circuitry, to form a singular integrated circuit. No separate reference oscillator is required. The various exemplary embodiments of the invention include features for highly accurate frequency generation over fabrication process, voltage, and temperature ("PVT") variations. These features include frequency tuning and selection, and compensation for frequency variations which may be caused due to temperature and/or voltage fluctuations, fabrication process variations, and variations due to aging of the integrated circuitry. [0010] The exemplary embodiments of the frequency controller of the present invention also provide several different levels and types of control. For example, both discrete and continuous control are provided, in real time, for control over output frequency of the free-running oscillator in light of such variations. In addition, such

control is provided generally as an open-loop, without requiring or necessitating a feedback connection and without requiring continuous locking of the oscillator to another reference signal.

[0010] In addition, the various exemplary embodiments of the invention provide a clock generator and/or a timing and frequency reference having multiple operating modes, including modes such as a power conservation mode, a clock mode, a reference mode, and a pulsed mode. In addition, the various embodiments provide multiple output signals at different frequencies, and provide low-latency and glitch-free switching between these various signals.

[0011] Significantly, the various exemplary embodiments of the invention generate a significantly and comparatively high frequency, such as in the hundreds of MHz and GHz range, which is then divided to a plurality of lower frequencies. Each such division by “N” (a rational number, as a ratio of integers) results in a significant noise reduction, with phase noise reduced by N and phase noise power reduced by N^2 . As a consequence, the various exemplary embodiments of the invention result in significantly less relative period jitter than other oscillators that generate their output directly or through frequency multiplications.

[0012] The various apparatus embodiments include a resonator, an amplifier, and a frequency controller, which may include various components or modules such as a temperature compensator, a process variation compensator, a voltage isolator and/or voltage compensator, an age (time) variation compensator, a frequency divider, and a frequency selector. The resonator provides a first signal having a resonant frequency. A temperature compensator adjusts the resonant frequency in response to temperature, and the process variation compensator adjusts the resonant frequency in response to fabrication process variation. In addition, the various embodiments may also include a frequency divider to divide the first signal having the resonant frequency into a plurality of second signals having a corresponding plurality of frequencies which are substantially equal to or lower than the resonant frequency; and a frequency selector to provide an output signal from the plurality of second signals. The frequency selector may further include a glitch-suppressor. The output signal may be provided in any of various forms, such as differential or single-ended, and substantially square-wave or sinusoidal.

[0013] The exemplary embodiments of the present invention provide an apparatus for frequency control of an integrated, free-running harmonic oscillator, comprising a resonator adapted to provide a first signal having a resonant frequency; a sensor adapted to provide a second signal, such as a control voltage, in response to at least one parameter of a plurality of parameters; and a frequency controller coupled to the sensor and couplable to the resonator, with the frequency controller adapted to modify a reactance element coupled to the resonator in response to the second signal to modify the resonant frequency. The plurality of parameters are variable and comprise at least one of the following parameters: temperature, fabrication process, voltage, frequency, and age (i.e., elapsed time).

[0014] In the exemplary embodiments, the frequency controller is further adapted to modify an effective reactance or impedance element coupled to the resonator in response to the second signal, such as modifying a total capacitance of

the resonator in response to the second signal, coupling to the resonator or decoupling from the resonator a fixed or variable capacitance, modifying an effective reactance of the resonator by varying or switching a varactor to a selected control voltage, or equivalently, modifying an inductance or resistance of the resonator in response to the second signal, such as by coupling to the resonator or decoupling from the resonator a fixed or variable inductance or resistance. In other embodiments, differentially weighted or sized reactances, such as variable capacitors (varactors), may be switched to or from the resonator, switched to or from a plurality of different, selectable control voltages, or both. For example, in selected embodiments, the reactance of one or more variable capacitors which are coupled to the resonator may be varied by switching the one or more variable capacitors to a selected control voltage, of a plurality of control voltages, resulting in differently or differentially-weighted effective reactances coupled to the resonator.

[0015] For example, a plurality of fixed capacitances (having different, binary weighted or otherwise differentially-weighted capacitances), may be coupled to the resonator to provide a discrete level of frequency control, and a varactor coupled to the resonator may be provided with a selected control voltage, of a plurality of control voltages, which varies in response to temperature, which may be utilized to maintain a constant frequency over such temperature fluctuations, and which provides a continuous level of frequency control. In addition, any of such control voltages may either vary in response to a selected parameter, such as temperature, or may be constant with respect to such a parameter. The differing weights of the various reactances utilized may be embodied in a plurality of forms, such as binary weighted, linearly weighted, or weighted utilizing any other desirable scheme, all of which are considered equivalent and within the scope of the present invention.

[0016] It should be noted that the terms “fixed” and “variable” are utilized as known in the art, with “fixed” being understood to mean configured generally to be non-varying with respect to a selected parameter, and “variable” meaning configured generally to be varying with respect to the selected parameter. For example, a fixed capacitor generally means that its capacitance does not vary as a function of an applied voltage, while a variable capacitor (varactor) will have a capacitance which does vary as a function of applied voltage. Both, however, may have and generally will have capacitances which vary as a function of fabrication process variation. In addition, a fixed capacitor may be formed as a varactor coupled to a constant voltage, for example. Those of skill in the art will recognize these various circumstances and contexts, as illustrated and as discussed below, and what is meant when such terms are utilized.

[0017] In the exemplary embodiments, the frequency controller may further comprise: a coefficient register adapted to store a first plurality of coefficients; and a first array having a plurality of switchable capacitive modules coupled to the coefficient register and couplable to the resonator, each switchable capacitive module having a fixed capacitance and a variable capacitance, each switchable capacitive module responsive to a corresponding coefficient of the first plurality of coefficients to switch between the fixed capacitance and the variable capacitance and to switch each variable capacitance to a control voltage. The plurality of switchable

capacitive modules may be binary-weighted. The frequency controller may further comprise a second array having a plurality of switchable resistive modules coupled to the coefficient register and further having a capacitive module, the capacitive module and the plurality of switchable resistive modules further coupled to a node to provide the control voltage, with each switchable resistive module responsive to a corresponding coefficient of a second plurality of coefficients stored in the coefficient register to switch the switchable resistive module to the control voltage node. In selected embodiments, the sensor further comprises a current source responsive to temperature, wherein the current source is coupled through a current mirror to the second array to generate the control voltage across at least one switchable resistive module of the plurality of switchable resistive modules. Also in selected embodiments, the current source has at least one complementary to absolute temperature ("CTAT") configuration, proportional to absolute temperature ("PTAT") configuration, proportional to absolute temperature squared ("PTAT²") configuration, or combinations of these configurations. In addition, each switchable resistive module of the plurality of switchable resistive modules has a different temperature response for a selected current.

[0018] In other exemplary embodiments, the sensor is a parameter (temperature, process, voltage, age, etc.) sensor and varies the second signal in response to variation of the selected parameter; for example, the sensor may be a temperature or voltage sensor and varies the second signal in response to temperature or voltage variation. The selected embodiments may also include an analog-to-digital converter coupled to the sensor to provide a digital output signal in response to the second signal, and a control logic block to convert the digital output signal to the first plurality of coefficients.

[0019] In other exemplary embodiments, the frequency controller further comprises a process variation compensator coupleable to the resonator and adapted to modify the resonant frequency in response to a fabrication process parameter of the plurality of parameters. The process variation compensator may further comprise a coefficient register adapted to store a plurality of coefficients; and an array having a plurality of binary-weighted switchable capacitive modules coupled to the coefficient register and to the resonator, each switchable capacitive module having a first fixed capacitance and a second fixed capacitance, with each switchable capacitive module responsive to a corresponding coefficient of the plurality of coefficients to switch between the first fixed capacitance and the second fixed capacitance. In other exemplary embodiments, the process variation compensator may further comprise a coefficient register adapted to store a plurality of coefficients; and an array having a plurality of switchable variable capacitive modules coupled to the coefficient register and to the resonator, each switchable variable capacitive module responsive to a corresponding coefficient of the plurality of coefficients to switch between a first voltage and a second voltage, such as switching to a selected control voltage.

[0020] In other exemplary embodiments, frequency controller further comprises a coefficient register adapted to store a first plurality of coefficients; and a first array having a plurality of switchable, capacitive modules coupled to the coefficient register and coupleable to the resonator, each

switchable capacitive module having a variable capacitance, each switchable capacitive module responsive to a corresponding coefficient of the first plurality of coefficients to switch the variable capacitance to a selected control voltage of a plurality of control voltages. In other exemplary embodiments, the process variation compensator may further comprise a coefficient register adapted to store at least one coefficient; and at least one switchable variable capacitive module coupled to the coefficient register and to the resonator, which is responsive to the at least one coefficient to switch to a selected control voltage. The sensor may comprise a current source responsive to temperature, and the frequency controller may also include a second array having a plurality of resistive modules coupled through a current mirror to the current source, the plurality of resistive modules adapted to provide the plurality of control voltages, and wherein each resistive module of the plurality of resistive modules has a different response to temperature and is adapted to provide a corresponding control voltage, of the plurality of control voltages, in response to a current from the current source.

[0021] In other exemplary embodiments, an apparatus for frequency control of a resonator comprises a coefficient register adapted to store a first plurality of coefficients; and a first array having a plurality of switchable reactance or impedance modules coupled to the coefficient register and to the resonator, each switchable reactance module responsive to a corresponding coefficient of the first plurality of coefficients to switch a corresponding reactance to modify the resonant frequency. The corresponding reactance or impedance may be a fixed or variable inductance, a fixed or variable capacitance, a fixed or variable resistance, or any combination thereof. The corresponding reactance may be switched to the resonator or, when coupled to the resonator, may be switched to a control voltage, a power supply voltage or a ground potential, and the control voltage may be determined by a current source responsive to temperature. For example, the corresponding reactance is variable and is coupled to the resonator and switched to a selected control voltage of a plurality of control voltages. In selected embodiments, the first plurality of coefficients are calibrated or are determined by a sensor responsive to at least one parameter of a plurality of variable parameters, such as temperature, fabrication process, voltage, frequency and age.

[0022] In other exemplary embodiments, an apparatus for frequency control of an integrated, free-running harmonic oscillator comprises: a plurality of resistive modules adapted to generate a plurality of control voltages; a plurality of controlled reactance modules coupled to the harmonic oscillator; and a plurality of switches coupled to the plurality of resistive modules and to the plurality of controlled reactance modules, with the plurality of switches responsive to a control signal to couple a first control voltage of the plurality of control voltages to a first controlled reactance module of the plurality of controlled reactance modules to modify a resonant frequency of the harmonic oscillator.

[0023] As illustrated above, the apparatus may also include a current source coupled to the plurality of resistive modules, with the current source adapted to provide a parameter-dependent current to at least one resistive module of the plurality of resistive modules to generate at least one control voltage, of the plurality of control voltages, which is

parameter-dependent. In other embodiments, the current source is adapted to provide a substantially parameter-independent current to at least one resistive module of the plurality of resistive modules to generate at least one control voltage, of the plurality of control voltages, which is substantially parameter-independent. Depending upon the exemplary embodiment, each switchable resistive module of the plurality of switchable resistive modules may have a different temperature response for a selected current. As a consequence, when the parameter is temperature, at least one control voltage of the plurality of control voltages is temperature-dependent and at least one control voltage of the plurality of control voltages is substantially temperature-independent.

[0024] The exemplary apparatus may also comprise a coefficient register coupled to the plurality of switches and adapted to store a first plurality of coefficients, wherein the control signal is provided by at least one coefficient of the first plurality of coefficients. The plurality of controlled reactance modules may further comprise a plurality of differentially (e.g., binary) weighted fixed capacitances and variable capacitances, and wherein the plurality of switches are responsive to the first plurality of coefficients to couple a fixed capacitance to the harmonic oscillator and to couple a first control voltage of the plurality of control voltages to a variable capacitance coupled to the harmonic oscillator. The plurality of resistive modules may further comprise a plurality of switchable resistive modules coupled to the coefficient register and a capacitive module, the capacitive module and the plurality of switchable resistive modules further coupled to a node to provide the first control voltage, with each switchable resistive module responsive to a corresponding coefficient of a second plurality of coefficients stored in the coefficient register to switch the switchable resistive module to the control voltage node.

[0025] In exemplary embodiments, an analog-to-digital converter may be coupled to the plurality of switchable resistive modules to provide a digital output signal in response to the first control voltage, to, for example, convert a temperature-dependent current (as a sensor) to a digital form; and a control logic block to convert the digital output signal to the first plurality of coefficients or to the control signal.

[0026] Also in exemplary embodiments, the plurality of controlled reactance modules further comprise: a plurality of switchable capacitive modules coupled to the coefficient register and couplable to the harmonic oscillator, with each switchable capacitive module having a variable capacitance, and with each switchable capacitive module responsive to a corresponding coefficient of the first plurality of coefficients to switch the variable capacitance to a selected control voltage of the plurality of control voltages. Depending upon the embodiment, a current source which is responsive to a parameter of a plurality of variable parameters is coupled through a current mirror to the plurality of resistive modules; wherein each resistive module of the plurality of resistive modules has a different response to the parameter and is adapted to provide a corresponding control voltage, of the plurality of control voltages, in response to a current from the current source. Depending upon the embodiment, at least one control voltage of the plurality of control voltages is

substantially parameter-dependent and at least one control voltage of the plurality of control voltages is substantially parameter-independent.

[0027] Also in exemplary embodiments, the plurality of controlled reactance modules further comprise: a plurality of differentially-weighted switchable capacitive modules coupled to the coefficient register and to the harmonic oscillator, each switchable capacitive module having a first fixed capacitance and a second fixed capacitance, each switchable capacitive module responsive to a corresponding coefficient of the plurality of coefficients to switch between the first fixed capacitance and the second fixed capacitance. In other embodiments, the plurality of controlled reactance modules further comprise: a plurality of switchable variable capacitive modules coupled to the coefficient register and to the harmonic oscillator, each switchable variable capacitive module responsive to a corresponding coefficient of the plurality of coefficients to switch between a first voltage and a second voltage of a plurality of control voltages. And in other embodiments, the plurality of controlled reactance modules further comprise: a plurality of switchable variable capacitive modules coupled to the coefficient register and to the harmonic oscillator, each switchable variable capacitive module responsive to a corresponding coefficient of the plurality of coefficients to switch to a selected control voltage of a plurality of control voltages, the plurality of control voltages comprising a plurality of different magnitude voltages, and wherein the selected control voltage is substantially constant over temperature variations.

[0028] Also in exemplary embodiments, the apparatus may further comprise: a plurality of switchable resistors responsive to a control signal to switch a corresponding resistance to the harmonic oscillator to modify the resonant frequency. The apparatus may include a voltage divider coupled to the plurality of controlled reactance modules and adapted to provide a selected control voltage responsive to voltage variations. In addition, an age variation compensator may be coupled to the resonator and adapted to compare a current value of a selected parameter of the plurality of parameters to an initial value of the selected parameter and to modify the resonant frequency in response to a difference between the current value and the initial value of the selected parameter.

[0029] Numerous other exemplary embodiments are illustrated and described in detail below, and include additional modulators and compensators for voltage variations and age (IC lifetime) variations.

[0030] The present invention may also include a mode selector coupled to the frequency selector, wherein the mode selector is adapted to provide a plurality of operating modes, which may be selected from a group comprising a clock mode, a timing and frequency reference mode, a power conservation mode, and a pulsed (or pulse) mode.

[0031] For a reference mode, the invention may also include a synchronization circuit coupled to the mode selector; and a controlled oscillator coupled to the synchronization circuit and adapted to provide a third signal; wherein in the timing and reference mode, the mode selector is further adapted to couple the output signal to the synchronization circuit to control timing and frequency of the third signal. Such a synchronization circuit may be a delay-locked loop, a phase-locked loop, or an injection locking circuit.

[0032] These and additional embodiments are discussed in greater detail below. Numerous other advantages and features of the present invention will become readily apparent from the following detailed description of the invention and the embodiments thereof, from the claims and from the accompanying drawings.

BRIEF DESCRIPTION OF THE DRAWINGS

[0033] The objects, features and advantages of the present invention will be more readily appreciated upon reference to the following disclosure when considered in conjunction with the accompanying drawings and examples which form a portion of the specification, wherein like reference numerals are used to identify identical or similar components in the various views, in which:

[0034] **FIG. 1** (or "**FIG. 1**") is a block diagram illustrating an exemplary system embodiment in accordance with the teachings of the present invention.

[0035] **FIG. 2** (or "**FIG. 2**") is a block diagram illustrating a first exemplary apparatus embodiment in accordance with the teachings of the present invention.

[0036] **FIG. 3** (or "**FIG. 3**") is a block diagram illustrating a second exemplary apparatus embodiment in accordance with the teachings of the present invention.

[0037] **FIG. 4** (or "**FIG. 4**") is a high-level schematic and block diagram illustrating exemplary frequency controller, oscillator and frequency calibration embodiments in accordance with the teachings of the present invention.

[0038] **FIG. 5A** (or "**FIG. 5A**") is an exemplary graph illustrating oscillator voltage waveform (frequency) distortion due to a harmonic content of current injected into an oscillator with a specific filter response.

[0039] **FIG. 5B** (or "**FIG. 5B**") is an exemplary graph illustrating oscillator voltage waveform (frequency) shown in **FIG. 5A** as a function of temperature.

[0040] **FIG. 5C** (or "**FIG. 5C**") is an exemplary graph illustrating oscillator frequency as a function of the transconductance of a sustaining amplifier.

[0041] **FIG. 6** (or "**FIG. 6**") is a circuit diagram illustrating first exemplary negative transconductance amplifier, temperature-responsive current generator (I(T)), and LC tank oscillator embodiments in accordance with the teachings of the present invention.

[0042] **FIG. 7A** (or "**FIG. 7A**") is a circuit diagram illustrating an exemplary temperature-responsive CTAT current generator in accordance with the teachings of the present invention.

[0043] **FIG. 7B** (or "**FIG. 7B**") is a circuit diagram illustrating an exemplary temperature-responsive PTAT current generator in accordance with the teachings of the present invention.

[0044] **FIG. 7C** (or "**FIG. 7C**") is a circuit diagram illustrating an exemplary temperature-responsive PTAT² current generator in accordance with the teachings of the present invention.

[0045] **FIG. 7D** (or "**FIG. 7D**") is a circuit diagram illustrating an exemplary selectable and scalable temperature-responsive current generator, with selected CTAT,

PTAT, and PTAT² configurations, in accordance with the teachings of the present invention.

[0046] **FIG. 8** (or "**FIG. 8**") is a circuit and block diagram illustrating second exemplary negative transconductance amplifier, temperature-responsive current generator (I(T)), and LC tank oscillator embodiments in accordance with the teachings of the present invention.

[0047] **FIG. 9** (or "**FIG. 9**") is a circuit diagram illustrating an exemplary first controlled (or controllable) capacitance module utilized in a frequency-temperature compensation module in accordance with the teachings of the present invention.

[0048] **FIG. 10** (or "**FIG. 10**") is a circuit diagram illustrating an exemplary first voltage control module utilized in a frequency-temperature compensation module in accordance with the teachings of the present invention.

[0049] **FIG. 11** (or "**FIG. 11**") is a circuit diagram illustrating an exemplary first process variation compensation module in accordance with the teachings of the present invention.

[0050] **FIG. 12** (or "**FIG. 12**") is a circuit diagram illustrating an exemplary second process variation compensation module in accordance with the teachings of the present invention.

[0051] **FIG. 13** (or "**FIG. 13**") is a block diagram illustrating an exemplary frequency calibration module in accordance with the teachings of the present invention.

[0052] **FIG. 14** (or "**FIG. 14**") is a block diagram illustrating an exemplary frequency divider, square wave generator, asynchronous frequency selector and glitch suppression module in accordance with the teachings of the present invention.

[0053] **FIG. 15** (or "**FIG. 15**") is a graphical diagram illustrating exemplary low latency frequency switching in accordance with the teachings of the present invention.

[0054] **FIG. 16** (or "**FIG. 16**") is a block diagram illustrating an exemplary frequency divider in accordance with the teachings of the present invention.

[0055] **FIG. 17** (or "**FIG. 17**") is a block diagram illustrating an exemplary power mode selection module in accordance with the teachings of the present invention.

[0056] **FIG. 18** (or "**FIG. 18**") is a block diagram illustrating an exemplary synchronization module for a second oscillator in accordance with the teachings of the present invention.

[0057] **FIG. 19** (or "**FIG. 19**") is a flow diagram illustrating an exemplary method in accordance with the teachings of the present invention.

[0058] **FIG. 20** (or "**FIG. 20**") is a block and circuit diagram illustrating an exemplary controlled impedance module utilized in a compensation module in accordance with the teachings of the present invention.

[0059] **FIG. 21** (or "**FIG. 21**") is a block diagram illustrating a first exemplary frequency controller and apparatus in accordance with the teachings of the present invention.

[0060] **FIG. 22** (or "**FIG. 22**") is a circuit diagram illustrating an exemplary second controlled capacitance module

utilized in a frequency-temperature compensation module in accordance with the teachings of the present invention.

[0061] **FIG. 23** (or “**FIG. 23**”) is a circuit diagram illustrating an exemplary second voltage control module utilized in a frequency-temperature compensation module in accordance with the teachings of the present invention.

[0062] **FIG. 24** (or “**FIG. 24**”) is a graph illustrating exemplary frequency control in response to temperature variation in accordance with the teachings of the present invention.

[0063] **FIG. 25** (or “**FIG. 25**”) is a block diagram illustrating a second exemplary frequency controller and apparatus in accordance with the teachings of the present invention.

[0064] **FIG. 26** (or “**FIG. 26**”) is a circuit diagram illustrating an exemplary third controlled capacitance module and an exemplary third voltage control module utilized in a parameter compensation module in accordance with the teachings of the present invention.

[0065] **FIG. 27** (or “**FIG. 27**”) is a circuit and block diagram illustrating an exemplary voltage variation compensation module in accordance with the teachings of the present invention.

[0066] **FIG. 28** (or “**FIG. 28**”) is a circuit diagram illustrating an exemplary fourth voltage control module utilized in frequency and process compensation modules in accordance with the teachings of the present invention.

[0067] **FIG. 29** (or “**FIG. 29**”) is a circuit diagram illustrating an exemplary resistive control module in accordance with the teachings of the present invention.

[0068] **FIG. 30** (or “**FIG. 30**”) is a block diagram illustrating an exemplary age variation compensator in accordance with the teachings of the present invention.

DETAILED DESCRIPTION OF THE EXEMPLARY EMBODIMENTS

[0069] While the present invention is susceptible of embodiment in many different forms, there are shown in the drawings and will be described herein in detail specific examples and embodiments thereof, with the understanding that the present disclosure is to be considered as an exemplification of the principles of the invention and is not intended to limit the invention to the specific examples and embodiments illustrated.

[0070] As indicated above, the various embodiments of the invention provide numerous advantages, including the ability to integrate a highly accurate (over PVT and age), low-jitter, free-running and self-referencing clock generator and/or a timing and frequency reference with other circuitry, such as illustrated in **FIG. 1**. **FIG. 1** is a block diagram illustrating an exemplary system embodiment **150** in accordance with the teachings of the present invention. As illustrated in **FIG. 1**, the system **150** is a single integrated circuit, having a clock generator and/or timing/frequency reference **100** of the present invention integrated monolithically with other, or second, circuitry **180**, together with interface (I/F) (or input/output (I/O) circuitry) **120**. The interface **120** will generally provide power, such as from a power supply (not illustrated), ground, and other lines or busses to the clock

generator **100**, such as for calibration and frequency selection. As illustrated, one or more output clock signals are provided on bus **125**, as a plurality of frequencies, such as a first frequency (f_0), a second frequency (f_1), and so on, through an $(n+1)^{\text{th}}$ frequency (f_n). In addition, a power conservation mode (or low power mode (LP)) is provided (also on bus **125**). The second circuitry **180** (or the I/F **120**) may also provide input into the clock generator **100**, such as through selection signals (S_0, S_1 , through S_n), and one or more calibration signals (C_0, C_1 , through C_n). Alternatively, the selection signals (S_0, S_1 , through S_n) and one or more calibration signals (C_0, C_1 , through C_n) may be provided directly to the clock generator **100** through the interface **120**, such as on bus **135**, along with power (on line **140**) and ground (on line **145**).

[0071] The clock generator and/or timing/frequency reference **100**, in addition to a low power mode, has additional modes discussed in greater detail below. For example, in a clock mode, the apparatus **100** will provide one or more clock signals, as output signals, to the second circuitry **180**. The second circuitry **180** may be any type or kind of circuitry, such as a microprocessor, a digital signal processor (“DSP”), a radio-frequency circuit, for example, or any other circuit which could utilize the one or more output clock signals. Also for example, in a timing or frequency reference mode, the output signal from the apparatus **100** may be a reference signal, such as a reference signal for synchronization for a second oscillator. As a consequence, the terminology clock generator and/or timing/frequency reference will be utilized interchangeably herein, with the understanding that the clock generator will also generally provide a square-wave signal, which may or may not be provided with a timing/frequency reference, which may utilize a substantially sinusoidal signal instead. In addition, as discussed in greater detail below, the various embodiments of the invention also provided a pulsed mode, in which the output signal from clock generator and/or timing/frequency reference **100** is provided in bursts or intervals, for increased instruction processing efficiency and lower power consumption, for example.

[0072] It should be noted that the various signals, voltages, parameter-independent current sources, and so on, are referred to as “substantially” sinusoidal or square-wave signals, substantially constant control voltages, or substantially parameter-independent voltages or currents, for example. This is to accommodate the various fluctuations, noise sources and other distortions introduced which may cause such signals, voltages or currents to differ in practice from the more ideal depictions found in textbooks. For example, as discussed in greater detail below, exemplary “substantially” square-wave signals are depicted in **FIGS. 15A and 15B**, and exhibit a variety of distortions, such as undershoots, overshoots, and other variations, and are nonetheless considered to be very high quality square-waves in practice.

[0073] Several important features of the present invention are in system **150**. First, a highly accurate, low-jitter, free-running and self-referencing clock generator **100** is integrated monolithically with other (second) circuitry **180**, to form a singular integrated circuit (system **150**). This is in sharp contrast with the prior art, in which a reference oscillator is used to provide a clock signal, such as a crystal reference oscillator, which cannot be integrated with other

circuitry and is off-chip, as a second and separate device which must be connected through a circuit board to any additional circuitry. For example, in accordance with the present invention, the system **150**, including clock generator **100**, may be fabricated with other, second circuitry using conventional CMOS (complementary metal oxide semiconductor), BJT (bipolar junction transistor), BiCMOS (bipolar and CMOS), or other fabrication technologies utilized in modern IC manufacturing.

[0074] Second, no separate reference oscillator is required. Rather, in accordance with the invention, the clock generator **100** is self-referencing and free-running, such that it is not referenced to or locked to another signal, such as being synchronized in a phase locked loop (“PLL”), delay locked loop (“DLL”), or via injection locking to a reference signal, which is typical of the prior art.

[0075] Third, the clock generator **100** provides a plurality of output frequencies and a power conservation mode, such that frequencies may be switched with low latency and in a glitch-free manner. For example, second circuitry **180** may shift to a power conservation mode, such as a battery or lower frequency mode, and request (through selection signals) a lower clock frequency for minimizing power consumption, or request a low power clock signal to enter a sleep mode. As discussed in greater detail below, such frequency switching is provided with substantially negligible latency, with low latency introduced for glitch prevention (in proportion to the number of glitch prevention stages utilized), using a merely a handful of clock cycles, rather than the thousands of clock cycles required to change the output frequency from a PLL/DLL.

[0076] In addition, given the significantly high available output frequencies of the clock generator and/or timing/frequency reference **100** discussed below, new operating modes are available. For example, clock start-up times are effectively or substantially negligible, allowing the clock generator and/or timing/frequency reference **100** to be repeatedly started and stopped, such as turned off entirely or to be pulsed for power conservation. For example, rather than running continuously as a clock, the clock generator and/or timing/frequency reference **100** can be operated in comparatively short, discrete intervals or bursts (i.e., pulsed), periodically or non-periodically, for instruction processing by a second circuit **180**, such as a processor. As discussed in greater detail below, with the rapid start-up time, such pulsed operation provides a power savings, as more instructions (million instructions per second or MIPS) are processed per milliwatt (mW) of power consumption. In addition, such a pulsed mode may also be utilized to periodically synchronize a second clock or oscillator, in addition to other uses. As a consequence, the clock generator and/or timing/frequency reference **100** (and the other embodiments discussed below) has a plurality of operating modes, including a clock mode, a timing and/or frequency reference mode, a power conservation mode, and a pulsed mode.

[0077] Fourth, as discussed in greater detail below, the clock generator and/or timing/frequency reference **100** includes features for highly accurate frequency generation over fabrication process, voltage, temperature (“PVT”) and age variations. These features include frequency tuning and selection, and compensation for frequency variations which

may be caused due to temperature and/or voltage fluctuations, fabrication process variations, and IC aging.

[0078] Fifth, the clock generator and/or timing/frequency reference **100** generates a significantly and comparatively high frequency, such as in the hundreds of MHz and GHz range, which is then divided to a plurality of lower frequencies. Each such division by “N” (a rational number, as a ratio of integers) results in a significant noise reduction, with phase noise reduced by N and phase noise power reduced by N^2 . As a consequence, the clock generator of the present invention results in significantly less relative period jitter than available with other oscillators that generate their output directly or through frequency multiplication.

[0079] These features are illustrated in greater detail in **FIG. 2**, which is a block diagram illustrating a first exemplary apparatus **200** embodiment, including a frequency controller **215** in accordance with the teachings of the present invention. As illustrated in **FIG. 2**, the apparatus **200** is a clock generator and/or timing/frequency reference, providing one or more output signals, such as a clock or reference signal having any of a plurality of frequencies, selected using frequency selector **205**. The apparatus (or clock generator) **200** includes an oscillator **210** (having a resonant element), a frequency controller **215**, a frequency divider **220**, a mode selector **225**, and the frequency selector **205** mentioned above. In accordance with the invention, the oscillator **210** generates a signal having a comparatively high frequency, f_0 . Due to PVT or age variations mentioned above, the frequency controller **215** is utilized to frequency select or tune the oscillator **210**, such that the oscillation frequency f_0 is selectable from a plurality of potential oscillation frequencies, i.e., the frequency controller **215** provides for output signals having frequencies which are accurate over PVT and age variations.

[0080] For example, given these PVT variations, the output frequency from an oscillator, such as oscillator **210**, may vary plus or minus 5%. For some applications, such as those utilizing ring oscillators, such frequency variability may be acceptable. In accordance with the present invention, however, greater accuracy for the clock generator **200** is desirable, particularly for more sensitive or complex applications, such as providing clock signals for integrated microprocessors, microcontrollers, digital signal processors, communication controllers, and so on. As a consequence, frequency controller **215** is utilized to adjust for these PVT variations, such that the output frequency from the oscillator is the selected or desired frequency f_0 with much less variance by several orders of magnitude, such as $\pm 0.25\%$ or less, and having a comparatively low-jitter.

[0081] Various exemplary embodiments of the frequency controller **215**, in accordance with the teachings of the present invention, are illustrated in detail below. For example, referring to **FIG. 21**, which is a block diagram illustrating an exemplary frequency controller **1415** and apparatus **1400** in accordance with the teachings of the present invention, an oscillator (resonator **310** and sustaining amplifier **305**) provides a first output signal having a resonant frequency f_0 . The exemplary frequency controller **1415** is coupled to the oscillator and modifies the resonant frequency f_0 in response to a second signal, such as a second signal provided by one or more sensors **1440**. The exemplary frequency controller **1415** comprises one of more of

the following components: transconductance modulator **1420**, variable parameter modulator (or controller) **1425** (such as one or more of the controlled capacitance or controlled reactance modules discussed below), process (or other parameter) modulator (or compensator) **1430**, voltage compensator **1455**, coefficient register(s) **1435**, and potentially also an age variation compensator **1460**. Depending upon the selected embodiment, the frequency controller **1415** may also include one or more sensor(s) **1440**, analog-to-digital (A/D) converter (“ADC”) **1445**, and control logic block **1450**. For example, a temperature-dependent current source, $I(T)$ (or, more generally, $yI(x)$) generator **415** illustrated in **FIG. 4** effectively functions as a temperature sensor in accordance with the present invention, providing a corresponding output current which varies as a function of ambient or junction temperature. Such a temperature-dependent output current may be converted into a digital signal by A/D converter (ADC) **1445**, and utilized to provide corresponding coefficients (stored in registers **1435**) utilized by the various modulators or compensators **1420**, **1425**, **1430**, **1455** and **1460** of the frequency controller **1415**, to control the resonant (or output) frequency f_0 in light of various parameters, such as a variable operating temperature or variable fabrication processes. In other illustrated embodiments, such a temperature-dependent output current is provided directly (as a second signal, without intervening A/D conversion) to the various modulators, such as transconductance modulator **1420** and to variable parameter modulator (or controller) **1425**. These modulators, in turn, modify the resonant frequency f_0 through, for example, modifying the current through the resonator **310** and sustaining amplifier **305**, or modifying the effective reactance or impedance (e.g., capacitance, inductance or resistance) coupled to and effectively forming part of the resonator **310**. For example, the effective reactance (or impedance) may be modified by coupling to or decoupling from the resonator **310** fixed or variable capacitances, or **10** modifying the magnitudes of one or more reactances coupled to the resonator, such as by modifying a control voltage or other continuous control parameter.

[0082] In the various illustrated embodiments discussed below, the transconductance modulator **1420** and variable parameter modulator (or controller) **1425** are generally implemented to utilize a temperature parameter, such that a substantially stable resonant frequency f_0 is provided over variations in operating temperature. It will be understood by those of skill in the art that these modulators may be implemented to provide a substantially stable resonant frequency f_0 as a function or in response to other variable parameters, such as variations due to fabrication process, voltage variations, aging, and other frequency variations.

[0083] Referring again to **FIG. 2**, to improve performance and decrease jitter (noise) and other interference, instead of generating a low frequency output and multiplying it up to a higher frequency, as is typically done using PLLs and DLLs, the present invention generates a comparatively high frequency output, f_0 , which is then divided to one or more lower frequencies (f_1 through f_n), using frequency divider **220**. Clock signals having one or more of the plurality of frequencies from frequency divider **220** may then be selected, using frequency selector **205**. As indicated above, such frequency selection is provided glitch-free and with low latency, providing comparatively and significantly fast

and glitch-free frequency switching. In addition, a plurality of operating modes are provided, using mode selector **225**.

[0084] **FIG. 3** is a block diagram illustrating in greater detail a second exemplary apparatus embodiment, as clock generator and/or timing/frequency reference **300**, in accordance with the teachings of the present invention. Referring to **FIG. 3**, clock generator and/or timing/frequency reference **300** comprises a resonator **310** and a sustaining amplifier **305** (forming an oscillator **395**), a temperature compensator (or modulator) **315**, a process variation compensator (or modulator) **320**, a frequency calibration module **325**, a voltage variation compensator (or modulator) **380**, an age (time) variation compensator (or modulator) **365**, one or more coefficient registers **340**, and depending on the selected embodiments, may also include a sensor(s) **385**, an analog-to-digital converter (“ADC”) **390**, frequency divider and square wave generator **330**, a voltage isolator **355**, a resonant frequency selector **360**, an output frequency selector **335**, a mode selector **345**, and a low-latency start-up module **399**. The sustaining amplifier **305**, temperature compensator **315**, process variation compensator **320**, voltage isolator **355**, voltage variation compensator **380**, age variation compensator **365**, resonant frequency selector **360**, and frequency calibration module **325** are often included within a frequency controller, such as frequency controller **349** (or **215** or **1415**). Alternatively, the sustaining amplifier **305** and resonator **310** may be considered to comprise an oscillator **395**, with one or more of the various controller elements (e.g., temperature compensator **315**, process variation compensator **320**, voltage isolator **355**, voltage variation compensator **380**, age variation compensator **365**, resonant frequency selector **360**, sensor(s) **385**, ADC **390**, and frequency calibration module **325**) included within a frequency controller **349** (or **215** or **1415**). It should also be noted that the square-wave generator (of **330**) may not be needed in timing or frequency reference embodiments.

[0085] The resonator **310** may be any type of resonator which stores energy, such as an inductor (L) and a capacitor (C) coupled to form an LC-tank, where the LC-tank has a selected configuration of a plurality of LC-tank configurations, or is otherwise electrically or electromechanically equivalent to or otherwise typically represented in the art as an inductor coupled to a capacitor. Such an LC-resonator is illustrated as resonator **405** in **FIG. 4**. In addition to LC resonators, other resonators are considered equivalent and within the scope of the present invention; for example, the resonator **310** may be a ceramic resonator, a mechanical resonator (e.g., XTAL), a microelectromechanical (“MEMS”) resonator, or a film bulk acoustic resonator. In other cases, various resonators may be represented by electrical or electromechanical analogy as LC resonators, and are also within the scope of the present invention. In exemplary embodiments, an LC-tank has been utilized as a resonator, to provide for a high Q-value for a completely integrated solution.

[0086] The sustaining amplifier **305** provides for both start-up and sustaining amplification for the resonator **310**. The temperature compensator **315** provides frequency control for the resonator **310**, to adjust the oscillation frequency based on variations due to temperature. In selected embodiments, depending upon the degree of control desired or required, the temperature compensator **315** may include control over both current and frequency, as illustrated below

for selected embodiments. For example, the temperature compensator **315** may comprise one or both of a transconductance modulator **1420** and variable parameter modulator **1425** of **FIG. 21**, with both modulators **1420** and **1425** embodied to be responsive to temperature fluctuations. Similarly, the process variation compensator **320** provides frequency control for the resonator **310**, to adjust the oscillation frequency based on process variations inherent in semiconductor fabrication technologies, both process variations within a given foundry (e.g., batch or run variations, variations within a given wafer, and die-to-die variations within the same wafer) and process variations among different foundries and foundry processes (e.g., 130 nm and 90 nm processes)). Voltage variation compensator **380** may be utilized to maintain a stable output frequency over supply voltage variations and other voltage variations. Age variation compensator **365** may be utilized to maintain a stable output frequency as the IC ages, with corresponding variations in circuit elements occurring over time. Frequency calibration module **325** is utilized to fine-tune and select the desired output frequency, f_0 , from among a plurality of oscillation frequencies which may occur in resonator **310**, i.e., to select the output frequency f_0 from a plurality of available or potential frequencies. In selected embodiments, coefficient registers **340** are utilized to store coefficient values utilized in the various exemplary compensator and calibration embodiments, discussed in greater detail below.

[0087] As mentioned above, the frequency controller **349**, in selected embodiments, may also include one of more sensors **385** and analog-to-digital converter (ADC) **390**. In addition, many of the other compensators and modulators of the frequency controller include components which function as sensors, such as temperature-dependent current sources and other voltage variation detectors. In addition to being utilized to generate various pluralities of stored coefficients which provide control to various switching elements, to both switch controlled reactance modules (discussed below) to the resonator **310** (as a discrete form of control) and to vary the amount of effective reactance supplied by a coupled or switched reactance to the resonator **310** (a continuous form of control), the various sensors, compensators and modulators may also be utilized to provide other forms of continuous control over the resonant frequency of the resonator **310**. The various continuous outputs from sensors, current generators, control voltages, etc., as illustrated and discussed below, function as control signals within the scope of the present invention. For example, the various control voltages, which may vary with a selected parameter (e.g., temperature) or which may be constant with respect to a selected parameter, function as control signals which are used to modify corresponding magnitudes of controlled capacitance modules implemented using varactors.

[0088] In addition to the temperature and process compensation, voltage isolator **355** provides isolation from variations in voltage, such as from a power supply, and may be implemented separately or as part of other components, such as part of temperature compensator **315**. In addition to frequency adjustment for these PVT and age variations, the resonant frequency may also be selected independently through resonant frequency selector **360**, for obtaining a selected frequency from a range of available frequencies.

[0089] For clock signal generation, clock generator **300** utilizes a frequency divider (in module **330**) to convert the

output oscillation frequency f_0 to a plurality of lower frequencies (f_1 through f_n) and to convert a substantially sinusoidal oscillation signal to a substantially square wave signal for clock applications, using a square wave generator (also in module **330**). Frequency selector **335** then provides for selection of one or more of the available output signals having the plurality of frequencies, and mode selector **345** may also provide for operating mode selection, such as providing a low power mode, a pulsed mode, a reference mode, and so on. Using these components, the clock generator **300** provides a plurality of highly accurate (over PVT), low jitter, and stable output frequencies, f_0 , f_1 through f_n , with minimal to negligible frequency drift due to such PVT variations, thereby providing sufficient accuracy and stability for sensitive or complex applications, as mentioned above.

[0090] **FIG. 4** is a high-level schematic and block diagram illustrating exemplary frequency controller, oscillator and frequency calibration embodiments in accordance with the teachings of the present invention. As illustrated in **FIG. 4**, the resonator is embodied as a resonant LC tank **405**, and the frequency controller is embodied as several elements, a negative transconductance amplifier **410** (used to implement the sustaining amplifier), a temperature-responsive (or temperature-dependent) current generator $I(T)$ (or, more generally, $yI(x)$, as responsive to any such parameter "x") **415**, a temperature-responsive (or temperature-dependent) frequency ($f_0(T)$) compensation module **420**, a process variation compensation module **425**, and may also include a frequency calibration module **430**. The various temperature-responsive or temperature-dependent modules **415** and **420** are sensitive to or responsive to temperature fluctuations, and provide corresponding adjustments, such that the resonant frequency is stable and accurate over these PVT and age variations.

[0091] The resonant LC tank **405** with a sustaining amplifier may be equally described as a harmonic oscillator or harmonic core, and all such variations are within the scope of the present invention. It should be noted that while the resonant LC tank **405** is an inductor **435** in parallel with a capacitor **440**, other circuit topologies are also known and equivalent to that illustrated, such as an inductance in series with a capacitance. Another such equivalent topology is illustrated in **FIG. 8**. In addition, as indicated above, other types of resonators may be utilized and all are considered equivalent to the exemplary resonant LC tank illustrated herein. Moreover, as discussed in greater detail below, additional capacitances and/or inductances, both fixed and variable (and referred to more generally as impedances or reactances (or reactive elements)), are distributed in the various modules and effectively form part of the resonant LC tank **405** and are utilized as part of the frequency controller of the invention. In addition, corresponding resistances (resistive components of the various impedances) R_L **445** and R_C **450** are illustrated separately, but should be understood to be intrinsic to the inductor **435** and capacitor **440**, respectively, occurring as part of fabrication, and are not additional or separate components from the respective inductor **435** and capacitor **440**. Conversely, such additional or intrinsic (parasitic) resistances can also be included as part of compensation for PVT variations, as illustrated and discussed below with reference to **FIG. 29**.

[0092] The inductor **435** and capacitor **440** of the resonant LC tank or oscillator **405** are sized to substantially or approximately provide the selected oscillation frequency, f_0 , or range of oscillation frequencies around f_0 . In addition, inductor **435** and capacitor **440** may be sized to have or to meet IC layout area requirements, with higher frequencies requiring less area. Those of skill in the art will recognize that $f_0 \approx 1/2\pi\sqrt{LC}$, but only as a first order approximation because, as discussed below, other factors such as the impedances R_L and R_C , any additional resistors, along with temperature and process variations and other distortions, affect f_0 , and may be included in second and third order approximations. For example, the inductor **435** and capacitor **440** may be sized to generate a resonant frequency in the 1-5 GHz range; in other embodiments, higher or lower frequencies may be desirable, and all such frequencies are within the scope of the invention. In addition, the inductor **435** and capacitor **440** may be fabricated using any semiconductor or other circuitry process technology, and may be CMOS-compatible, bipolar-junction transistor-compatible, for example, while in other embodiments, the inductor **435** and capacitor **440** may be fabricated using silicon-on-insulator (SOI), metal-insulator-metal (MiM), polysilicon-insulator-polysilicon (PiP), GaAs, strained-silicon, semiconductor heterojunction technologies, or MEMS-based (microelectromechanical) technologies, also for example and without limitation. It should be understood that all such implementations and embodiments are within the scope of the invention. In addition, other resonator and/or oscillator embodiments, in addition to or instead of the resonant LC tank **405**, may also be utilized and are also within the scope of the present invention. As used herein, "LC tank" will mean and refer to any and all inductor and capacitor circuit layouts, configurations or topologies which may provide oscillation, however embodied. It should be noted that the capability of the oscillator **405** to be fabricated using a conventional process, such as CMOS technology, allows the clock generator to be fabricated integrally and monolithically with other circuitry, such as the second circuitry **180**, and provides a distinct advantage of the present invention.

[0093] In addition, the capacitance **440** illustrated in FIG. 4 is only a portion of the overall capacitance involved in the resonance and frequency determination of the resonant LC tank **405**, and is a fixed capacitance. In selected embodiments, this fixed capacitance may represent approximately 10% to 90% of the total capacitance ultimately utilized in the oscillator, as an example. Alternatively, the capacitance **440** may also be implemented as a variable capacitance, if desired. As discussed in greater detail below, the overall capacitance is distributed, such that additional fixed and variable capacitance is selectively included within the clock generator and/or timing/frequency reference **300**, and is provided, for example, by components of the frequency controller (**215**, **1415**), such as temperature-responsive frequency ($f_0(T)$) compensation module **420** and process variation compensation module **425**, to provide for both selecting the resonant frequency f_0 and to allow the resonant frequency f_0 to be substantially independent of both temperature and process variations.

[0094] In the selected embodiments, the inductance **435** has been fixed, but also could be implemented in a variable manner, or as a combination of fixed and variable inductances. As a consequence, those of skill in the art will recognize that the detailed discussions of fixed and variable

capacitance, for both frequency tuning and temperature and process independence, pertain similarly to inductance choices. For example, different inductances could be switched in or out of the oscillator, to similarly provide tuning. In addition, a single inductor's inductance may also be modulated. As a consequence, all such inductance and capacitance variations are within the scope of the present invention, and are illustrated as switchable, variable and/or fixed reactive elements or components of the exemplary controlled impedance modules **1305** of FIG. 20 and the controlled reactance modules **1805** of FIGS. 25-27.

[0095] Also as illustrated in FIG. 4, the resonant LC tank **405** and resulting output signal, referred to as a first (output) signal at nodes or lines **470** and **475**, is a differential signal and provides common-mode rejection. Other configurations, including non-differential or other single-ended configurations are also within the scope of the present invention. For example, in single-ended configurations, only one instantiation of the various modules (e.g., **485**, **460**) would be required, rather than the use of two for a balanced configuration as illustrated. Similarly, other components and features discussed below, such as frequency dividers, would also have a single-ended rather than differential configuration. In addition, various embodiments illustrated utilize MOSFET transistors (metal oxide semiconductor field effect transistors) in various forms (such as CMOS, accumulation-mode MOSFET ("AMOS"), inversion-mode MOSFET ("IMOS"), and so on); other implementations are also available, such as using bipolar junction transistors ("BJTs"), BiCMOS, etc. All such embodiments are considered equivalent and are within the scope of the present invention.

[0096] The negative transconductance amplifier **410** is selected to provide temperature compensation through transconductance (g_m) modulation and the on-resistance of its resistors. Transconductance (g_m) modulation may also be utilized independently in frequency selection. Another significant advantage of the present invention is the selection of a negative transconductance amplifier **410** to provide start-up and sustaining amplification, because both oscillation amplitude and frequency are affected by the transconductance of the sustaining amplifier, providing both amplitude modulation and frequency trimming (or tuning), in addition to providing temperature compensation. The negative transconductance amplifier **410** will inject current into the resonant LC tank **405** (and specifically onto the capacitor **440**) in response to a voltage "v" across the resonant LC tank **405**, as illustrated (across nodes **470** and **475**). That current injection, in turn, will change (and distort) the voltage waveform (as voltage is the integral of the current), resulting in a change or variation in frequency, generally in inverse proportion to the magnitude of the transconductance, g_m , as illustrated in FIG. 5A. It should be noted that this transconductance is a negative value, as gain is provided to cancel the loss intrinsic to the resonant element. As a consequence, whenever "transconductance amplifier" is utilized herein, it should be understood to mean and to be merely an abbreviation for "negative transconductance amplifier". In turn, the transconductance is also a function of the bias current, substantially proportional (approximately) to the square root of the current ($yI(x)$) through the amplifier **410** (for MOSFETs), and substantially proportional (approximately) to the current ($yI(x)$) through the amplifier **410** (for BJTs), which is temperature-dependent, resulting in a waveform distortion which is both temperature and bias current dependent, as

illustrated in **FIG. 5B**. In addition, as illustrated in **FIG. 5C**, the oscillation frequency is also related to and a function of the transconductance of the sustaining negative transconductance amplifier **410**, providing for oscillation frequency selection. Moreover, in addition to temperature dependence (as $I(T)$), the current can also vary as a function of other parameters or variables (so is referred to more generally as current $I(x)$), such as voltage or external tuning, and may also be amplified such as by a factor of “ y ” (as illustrated below); as a consequence, the current is referred to as “ $yI(x)$ ”.

[0097] As indicated above, more generally, such a variable current $yI(x)$ may be utilized as or as part of a sensor, such as one or more sensors **1440** or transconductance modulator **1420** of **FIG. 21** or sensors **1815** of **FIG. 25**. For example, when such as variable current is provided by $I(T)$ generator **415**, such that the current provided is a function of temperature (parameter or variable “ x ”=temperature parameter “ T ”), $I(T)$ generator **415** thereby functions as a temperature sensor, and may be utilized as such in the exemplary embodiments, such as utilized by the frequency controller (**215**, **349**, **1415**) to adjust the resonant frequency f_0 in response to temperature fluctuations. For example, transconductance modulator **1420** of **FIG. 21** may comprise such a temperature (or other parameter) responsive current source **415** (which also functions as a sensor **1440**), providing current to a sustaining amplifier **305**.

[0098] Significant inventive breakthroughs of the present invention include utilizing these potential distortions advantageously, to provide for frequency compensation in generating the selected f_0 value of the oscillator, and frequency modulation through modulation of the transconductance of the sustaining amplifier. As a consequence, and as discussed in greater detail below, the transconductance, first, may be modified or varied for frequency selection, and second, to compensate for such frequency variation due to temperature, voltage, fabrication process or aging, by modifying the current $yI(x)$, generally on a real-time or near real-time basis. The selected frequency f_0 , and its stability with respect to temperature variations, in accordance with the invention, may be determined through appropriate selection of the transconductance g_m and selection of $I(T)$. Stated another way, in accordance with the present invention, the bias current is made temperature dependent, as $I(T)$ (or, more generally, as $yI(x)$), which in turn affects the transconductance g_m , which in turn affects the oscillation frequency f_0 . This methodology may also be utilized for other variables, such as voltage fluctuations, process variation, or aging variation.

[0099] **FIG. 6** is a circuit diagram illustrating exemplary negative transconductance amplifier (**410**), temperature-responsive current generator ($I(T)$ **415**), and LC tank resonator (**405**) embodiments in accordance with the teachings of the present invention. As illustrated in **FIG. 6**, a resonant LC tank **500** is coupled to a negative transconductance amplifier implemented as a complementary cross-coupled pair amplifier **505** (comprised of transistors **M1**, **M2**, **M3** and **M4**) which, in turn, is coupled through a voltage isolator **510** (implemented as current mirror (transistors **525A** and **525B**) and referred to interchangeably herein) to a temperature-responsive current generator ($I(x)$) **515**. The current mirror **510** (voltage isolator) may also be implemented in a cascode topology (**520A** and **520B**), such as to provide improved

stability with variations in power supply and isolate the oscillator from the power supply (voltage isolation). The temperature-responsive current generator **515** may be implemented utilizing topologies such as CTAT (complementary to absolute temperature), PTAT (proportional to absolute temperature), or $PTAT^2$ (proportional to absolute temperature squared), as illustrated in **FIGS. 7A**, **7B** and **7C**, respectively, and combinations of CTAT, PTAT, and $PTAT^2$, as illustrated in **FIG. 7D**. In each case, the current $I(T)$ (or $yI(x)$) injected into the negative transconductance amplifier (complementary cross-coupled pair amplifier) **505** has a temperature dependence, such as increasing current (PTAT and $PTAT^2$) or decreasing current (CTAT) as a function of increasing temperature, as illustrated. One or more combinations of these temperature-responsive current generators may also be implemented, as illustrated in **FIG. 7D**, such as CTAT in parallel with PTAT, for example.

[0100] The selection of a particular temperature-responsive or temperature-dependent current generator is also a function of the fabrication process utilized; for example, CTAT may be utilized for a Taiwan Semiconductor (TSMC) fabrication process. More generally, as different fabricators utilize different materials, such as aluminum or copper, R_L typically varies, resulting in different temperature coefficients which, in turn, change the temperature coefficient of the oscillator, thereby requiring differences in $I(T)$ compensation. Correspondingly, different ratios of CTAT, PTAT, and $PTAT^2$ compensation may be required to provide an effectively flat frequency response as a function of temperature. Not separately illustrated, the various temperature-responsive current generators illustrated in **FIGS. 7A**, **7B**, **7C** and **7D** may include a start-up circuit. In addition, the transistors comprising the selected temperature-responsive current generator configuration may be biased differently, such as biased in strong inversion for CTAT (**M7** and **M8**) and $PTAT^2$ (**M13** and **M14**), and in subthreshold for PTAT (**M9** and **M10**) and $PTAT^2$ (**M11** and **M12**), for the exemplary topologies illustrated.

[0101] **FIG. 8** is a circuit and block diagram illustrating additional exemplary negative transconductance amplifier, temperature-responsive (or temperature-dependent) current generator ($I(T)$ or $I(x)$), and LC tank oscillator embodiments in accordance with the teachings of the present invention. As illustrated in **FIG. 8**, the resonant LC tank **550** has a different topology than previously illustrated, but also is coupled to a negative transconductance amplifier implemented as a complementary cross-coupled pair amplifier **505** (transistors **M1**, **M2**, **M3** and **M4**) which, in turn, is coupled through a plurality of current mirrors **510** (or **520**) and **530** to a temperature-responsive (or temperature-dependent) current generator ($I(T)$ or $I(x)$) **515**. As illustrated, the plurality of current mirrors are utilized to successively provide gain to and increase the current $I(T)$ entering the negative transconductance amplifier **505** and resonant LC tank **550**. Often, the tail device in the current mirror (e.g., transistor **M6** in **FIG. 6**) providing current into node B and which drives the negative transconductance amplifier is selected to be a PMOS device, and thus several stages of mirroring may be required (as shown) to provide a PMOS current mirror input to the g_m amplifier. PMOS is often selected because in modern CMOS processes, PMOS devices are often buried channel devices which are known to exhibit less flicker noise than equally sized and similarly biased NMOS devices. Reduced flicker noise in the tail

device reduces the phase noise and jitter of the oscillator because flicker noise is upconverted around the oscillation frequency by the nonlinear active devices in the circuit.

[0102] As indicated above, the portion of the current mirror 510 or 520 (or other circuitry) sourcing current into the negative transconductance amplifier 505 should have a high impedance at its output to reduce power supply frequency drift, such as by using long transistor geometries and cascode configurations to increase output resistance, and provide significant stability at node B. In addition, a shunt capacitor 570 also may be employed to filter and thereby reduce flicker noise from the various tail devices.

[0103] Depending upon the selected application, the use of the negative transconductance amplifier 505 with its $I(T)$ (or $YI(x)$) bias may provide sufficient frequency stability, such that the additional frequency controller components may not be necessary or desirable in that application. In other embodiments, however, additional accuracy and less frequency drift may be provided, using one or more of the components discussed in greater detail below.

[0104] In addition to providing a temperature-dependent current $YI(x)$ (or $I(T)$), the various transistors M1, M2, M3 and M4 each have an associated resistance during conduction, which may also tend to cause frequency distortion and frequency drift during oscillation. In each half-cycle, either M1 and M4 or M2 and M3 are on and conducting. Such resistance is also temperature dependent. As a consequence, the transistors M1, M2, M3 and M4 should be adjusted in size (width and length) to also compensate for such frequency effects. It should be noted that the current injected into the resonant LC tank 405 must be sufficient to sustain oscillation (as illustrated in FIG. 5C) and, as a consequence, will have a minimum value, which may limit the degree or capability of frequency control which can be readily implemented through the negative transconductance amplifier 410 (or 505) and temperature-dependent current generator 415 (or 515). As a consequence, $I(T)$ and the transistor (M1, M2, M3 and M4) sizing should be jointly selected to provide for oscillation start up, to accommodate maximum currents for power consumption constraints, and to fit into the selected IC area and layout. For example, the transconductance g_m may be selected to provide approximately sufficient current to ensure start up and sustain oscillation, with a frequency characteristic of decreasing frequency with increasing temperature, followed by sizing transistors M1, M2, M3 and M4 to be large enough to either make the frequency independent of temperature or increasing with increasing temperature, followed by fine-tuning the frequency-temperature relationship with appropriate selection of $I(T)$. In selected modeled embodiments, this has resulted in frequency accuracy of approximately $\pm 0.25\%$ to 0.5% over PVT, which may be more than sufficient for many applications.

[0105] Referring again to FIG. 4, additional compensation modules are also utilized as part of frequency controller (215, 349, 1415) to provide greater control and accuracy over the resonant frequency f_0 , such as for applications in which greater accuracy and less variance (or frequency drift) may be required, or where technologies do not allow the previous techniques to provide sufficient accuracy over PVT or age variations, such as to provide a frequency accuracy of approximately $\pm 0.25\%$ or better. In these circumstances, temperature-dependent (or temperature-responsive) fre-

quency ($f_0(T)$) compensation module 420 may be utilized, such as the exemplary temperature-responsive frequency ($f_0(T)$) compensation module 420. This module 420 may be implemented, for example, utilizing controlled (or controllable) capacitance modules 485, with each coupled to a respective side or rail of the resonant LC tank 405 (lines 470 and 475), and with each under common control, provided by a first plurality (“w”) of switching coefficients (p_0 through $p_{(w-1)}$) (register 495) and a voltage controller (V_{CTRL}) 480 providing a control voltage determined by a second plurality (“x”) of switching coefficients (q_0 through $q_{(x-1)}$) (register 455), with representative examples illustrated in FIGS. 9 and 10. (The terms “controlled” and “controllable” are utilized interchangeably herein). Additional exemplary embodiments are illustrated in FIG. 20, which illustrates an exemplary controlled impedance module 1300 utilized in a frequency-temperature compensation module, such as in place of or in addition to controlled (or controllable) capacitance modules 485 in module 420; in FIG. 22, which illustrates another variation of controlled capacitance modules 485, as controlled capacitance modules 1500 with a plurality of temperature-dependent or other parameter-dependent control voltages (generated as illustrated FIGS. 23 or 26); in FIG. 25, which illustrates a plurality of controlled reactance modules 1805 which are switched in or out (coupled to or uncoupled from the resonator) in response to control signals from control logic 1810 and sensor(s) 1815, including feedback from the oscillator; in FIG. 26, which illustrates a plurality of controlled reactance modules 1805 which are switched in or out and/or switched to a control voltage, in response to control signals (continuous) or coefficients (discrete); and in FIG. 27, which illustrates a plurality of controlled reactance modules 1805 which are switched in response to control signals, for voltage variation compensation. There are several different types of switching available, such as coupling or uncoupling a reactance or impedance to the resonator, or switching coupled reactances or impedances to selected control voltages or other control signals, for example.

[0106] FIG. 9 is a circuit diagram illustrating an exemplary first controllable capacitance module 635 in accordance with the teachings of the present invention, which may be utilized as the controlled (or controllable) capacitance modules 485 in the frequency-temperature compensation module 420 (and attached to each side of the resonant LC tank 405 (nodes or lines 470 and 475)). As illustrated, the controlled (or controllable) capacitance module 635 is comprised of a bank or array of a plurality (w) of switchable capacitive modules 640 of binary-weighted fixed capacitors (C_f) 620 and binary- or other differentially-weighted variable capacitors (varactors) (C_v) 615. Any type of fixed capacitors 620 and variable capacitors (varactors) 615 may be utilized; in selected embodiments, the varactors 615 are AMOS (accumulation-mode MOSFET), IMOS (inversion-mode MOSFET), and/or junction/diode varactors. Each switchable capacitive module 640 has an identical circuit layout, and each differs by a binary weighted capacitance, with switchable capacitive module 640a having a capacitance of one unit, switchable capacitive module 640, having a capacitance of two units, and so on, with switchable capacitive module 640_(w-1) having a capacitance of $2^{(w-1)}$ units, with each unit representing a particular capacitance magnitude or value (typically in femtofarads (fF) or picofarads (pF)). As mentioned above, other differential weight-

ing schemes are equally applicable, such as linear or binary, and may also consist of providing such differential weighting by switching the reactance to a selected control voltage, thereby increasing or decreasing its effective reactance.

[0107] Within each switchable module 640, each fixed and variable capacitance is initially equal, with the variable capacitance allowed to vary in response to the control voltage provided at node 625. This control voltage, in turn, varies with temperature or another selected variable parameter, resulting in an overall or total capacitance provided by the controlled capacitance module 635 also varying as a function of temperature (or other parameter) and which, in turn, is utilized to vary the resonant frequency f_0 . In other selected embodiments, any of a plurality of control voltages may be utilized, including static control voltages, to provide for other types of compensation, discussed below. Also within each switchable capacitive module 640, either the fixed capacitance C_f or the variable capacitance C_v is switched into the circuit, not both, using switching coefficients p_0 through $p_{(n-1)}$. For example, in the selected embodiment, for a given or selected module 640, when its corresponding “p” coefficient is a logic high (or high voltage), the corresponding fixed capacitance C_f is switched into the circuit and the corresponding variable capacitance C_v is switched out of the circuit (and coupled to a power rail voltage V_{DD} or ground (GND), depending whether the device is AMOS or IMOS, respectively, to avoid a floating node and to minimize the capacitance presented to the tank), and when its corresponding “p” coefficient is a logic low (or low voltage), the corresponding fixed capacitance C_f is switched out of the circuit and the corresponding variable capacitance C_v is switched into the circuit and coupled to the control voltage provided on node 625.

[0108] In an exemplary embodiment, a total of eight switchable capacitive modules 640 (and corresponding first plurality of eight switching coefficients p_0 through p_7 have been implemented to provide 256 combinations of fixed and variable capacitances. As a result, significant control over oscillation frequency as a function of temperature variations is provided.

[0109] It should be noted, in this exemplary embodiment, by switching in or out the fixed capacitance C_f or the variable capacitance C_v , the ratio of fixed to variable changes and, correspondingly, the amount or degree of temperature-responsiveness of the controllable capacitance module 635. For example, with increasing amounts of variable capacitance C_v , the controllable capacitance module 635 provides greater variability of capacitance in response to temperature (or other parameter), thereby adjusting the frequency response of the tank or other oscillator.

[0110] FIG. 10 is a circuit diagram illustrating an exemplary temperature dependent voltage control module 650 utilized to provide the control voltage in the controllable capacitance module 635 (of the frequency-temperature compensation module 420) and as V_{CTRL} 480 (in FIG. 4), in accordance with the teachings of the present invention. As illustrated, voltage control module 650 creates a temperature-dependent current $I(T)$ (or more generally, a current $I(x)$), using current generator 655, as previously discussed, using one or more combinations of PTAT, $PTAT^2$ and/or CTAT current generators, and may share the $I(T)$ generator 415 utilized with the negative transconductance amplifier

410, instead of providing a separate generator 655. The temperature-dependent current $I(T)$ (or $I(x)$) is mirrored through current mirror 670 to an array or bank of a plurality of switchable resistive modules or branches 675 and a fixed capacitive module or branch 680, all configured in parallel. In other exemplary embodiments, depending upon the parameter variation to be compensated, other control voltage generators discussed below may be utilized.

[0111] In other combinations, depending upon the selection and weighting of the PTAT, $PTAT^2$ and/or CTAT current generators, a temperature-independent current may also be generated. For example, a PTAT generator and a CTAT generator, sized to have equal magnitudes and opposite slopes, can be combined to create a current generator which provides a constant current over temperature fluctuations. Such a current generator, for example, can be utilized to provide a constant current source in the aging variation compensator illustrated in FIG. 30. Those of skill in the art will recognize that other current sources may also be utilized, such as those which vary with power supply voltage, and may be utilized as corresponding voltage sensors.

[0112] The resistors 685 may be any type or combination of different types, such as diffusion resistors (p or n), polysilicon, metal resistors, salicide or unsalicide polysilicon resistors, or well resistors (p or n well), for example. Depending upon the type or combination of types of resistors selected, the resistors 685 generally will also have a corresponding temperature dependence (or responsiveness), providing a corresponding voltage variation across the selected resistor 685 as a function of temperature for a given current through the selected resistor 685. For example, a diffusion resistor will generally have a high temperature coefficient (providing more voltage variation with temperature), while a polysilicon resistor will generally have a low temperature coefficient (providing less voltage variation with temperature), while a mix of a plurality of these different resistor types in series for a selected module 675 will provide a corresponding response in between these high and low response levels. Alternatively, the resistors 685 may be sized or weighted to provide different voltage levels as a function of a given current, such as a temperature-dependent current (e.g., $I(T)$), also thereby providing a corresponding voltage variation as a function of temperature for such a temperature-varying current.

[0113] Each switchable resistive module 675 is switched in or out of the voltage control module 650 by a corresponding “q” coefficient of a second plurality (“x”) of switching coefficients q_0 through $q_{(n-1)}$. When switchable resistive module 675 is switched into the circuit (such as when its corresponding coefficient is a logic high or high voltage), the resulting voltage across its corresponding resistor 685 is also temperature-dependent, due to the temperature-dependent current $I(T)$. In a selected embodiment, three switchable resistive modules 675 were utilized, providing 8 branch combinations. As a result, the control voltage provided to node 625 is also a function of temperature (or other parameter), thereby providing a temperature or other parameter dependence or sensitivity to the variable capacitors 615 in controllable capacitance module 635. Other resistive modules which are more generally parameter-dependent, or which are temperature-independent, are discussed below with reference to FIGS. 23 and 26, and FIG. 28, respectively.

[0114] The first plurality of switching coefficients p_0 through $p_{(w-1)}$ and the second plurality of switching coefficients q_0 through $q_{(x-1)}$ may be determined post-fabrication by testing a representative IC having the clock generator of the present invention. Once a resonant frequency f_0 has been selected and/or calibrated for a given fabrication process (discussed below with reference to **FIGS. 11 and 12**), the temperature (or other parameter) responsiveness of the oscillator is determined and adjusted, to provide a substantially constant selected resonant frequency f_0 for such variation in ambient or operating temperature (or other variable parameter). In the exemplary embodiments, the first plurality of switching coefficients p_0 through $p_{(w-1)}$ are determined first, by testing various combinations of coefficients, to provide a coarse level of adjustment, resulting in a substantially or mostly flat frequency response as a function of varying ambient temperature. As illustrated in **FIG. 24**, more or less fixed capacitance C_f or variable capacitance C_v is switched into or out of the oscillator. For example, when the uncompensated frequency response of the oscillator to temperature variation is represented by lines **1705** or **1710**, additional variable capacitance C_v may be switched in, providing a coarse adjustment for the frequency response of the oscillator to approximately line **1715**. Conversely, also for example, when the uncompensated frequency response of the oscillator to temperature variation is represented by lines **1725** or **1730**, additional fixed capacitance C_f may be switched in, providing a coarse adjustment for the frequency response of the oscillator to approximately line **1720**.

[0115] The second plurality of switching coefficients q_0 through $q_{(x-1)}$ are then determined, also by testing various combinations of coefficients, to provide a finer level of adjustment, resulting in a substantially and significantly flat frequency response as a function of varying ambient temperature, illustrated in **FIG. 24** as adjusting a partially compensated frequency response (lines **1715** or **1720**) to the substantially flat response of line **1700**, through selection of the temperature responsiveness of the various resistors **685**. The first and second pluralities of coefficients are then loaded into respective registers **495** and **455** in all of the ICs fabricated in the selected processing run (or batch). Depending on the fabrication processing, under other circumstances, it is possible that for higher accuracy, each IC may be separately calibrated. As result, in conjunction with the temperature compensation provided by the negative transconductance amplifier **410** and I(T) generator **415**, the overall frequency response of the clock generator is substantially independent of temperature fluctuations.

[0116] In other exemplary embodiments, the first plurality of switching coefficients p_0 through $p_{(w-1)}$ and the second plurality of switching coefficients q_0 through $q_{(x-1)}$ may also be determined and varied dynamically during operation of the oscillator, such as through sensor(s) **1440** and A/D converter **1445**, as illustrated in **FIG. 21**, or through sensor(s) **1815** and control logic (or control loop) **1810** illustrated in **FIG. 25**. In these alternative embodiments, the stored first and second pluralities of coefficients may be eliminated or bypassed, with corresponding voltages applied directly as control signals to the respective switching components as illustrated in **FIGS. 9 and 10** (and, similarly, extended to the other pluralities of coefficients discussed below).

[0117] For example, as illustrated in **FIG. 26**, as discussed in greater detail below, any of a plurality of current sources **1955** may be provided in various combinations to a plurality of resistive modules, to create a plurality of control voltages responsive to a selected parameter "P", which may be switched in any combinations to each of the plurality of controlled reactance modules **1805**, which may be embodied, for example, as controlled capacitance modules **1505** (**FIG. 22**), to control the effective reactance of the resonator. In addition, any of a plurality of constant (temperature independent) control voltages may also be created, as illustrated in **FIG. 28**. Moreover, other or additional types of current sources may be utilized, either to generate the control voltage or to provide sensor **385**, **1440** capability, such as those which may vary with the supply voltage VDD, or which are independent of both supply voltage, temperature, and other parameters. Any of these control voltages may be utilized to provide continuous control in real time, in addition to discrete control, over parameter variations, such as temperature variations.

[0118] As a consequence, the overall capacitance provided to the resonant LC tank **405** is distributed into a combination of fixed and variable portions, with the variable portions responsive to provide temperature compensation and, therefore, control over the resonant frequency f_0 . The more variable capacitance C_v which is switched into the circuit (controlled capacitor module **635**), the greater the frequency response to fluctuations in ambient temperature. As indicated above, both fixed and variable capacitors may be implemented using variable capacitors (varactors) coupled or switched, respectively, to substantially constant or variable voltages.

[0119] In addition to providing temperature compensation, it should be noted that a switched or controlled (or controllable) capacitance module **635** may also be utilized to select or tune the resonant frequency f_0 . It will also be apparent to those of skill in the art that a switched or controllable capacitance module **635** may also be utilized to provide a frequency response to other parameter variations, such as fabrication process variations, frequency, and voltage fluctuations. In addition, as discussed below with reference to **FIGS. 20 and 25-27**, a capacitance, an inductance, a resistance, or any other reactance or impedance element may be utilized in these various exemplary embodiments, providing a controlled reactance or impedance module to provide a selected frequency response to any of a plurality of variable parameters, such as temperature, voltage, fabrication process, or frequency.

[0120] **FIG. 22** is a circuit diagram illustrating an exemplary second controlled capacitor module **1500** utilized (with module **1600** of **FIG. 23**) (in lieu of or in addition to modules **485** and **480**) in a frequency-temperature compensation module **420**, or more generally, in a frequency controller **215**, **349**, **1415**, in accordance with the teachings of the present invention. The second controlled capacitance module **1500** operates similarly to the first controlled capacitance module **635**, but utilizes variable capacitances, instead of both fixed and variable, and utilizes a plurality of different control voltages, instead of a single control voltage. In addition, such variable capacitances are not coupled to or decoupled from the resonator (i.e., the variable capacitances are always coupled to the resonator), and instead are switched to different control voltages to control the fre-

quency response as a function of a selected parameter such as temperature. Selected embodiments, moreover, may utilize as few as one module, and the differential weighting may be accomplished by switching to a selected control voltage of a plurality of control voltages.

[0121] Referring to FIG. 22, the second controlled capacitor module 1500 utilizes at least one of a plurality (“g”) of variable capacitance modules 1505, each of which contains variable capacitances (C_v) 1515_{A0} through 1515_{B(g-1)} (illustrated in pairs A and B, corresponding to balanced coupling to node 475 or 470, and illustrated with binary-weighting) which are switchable (through pluralities of transistors or other switches 1520₀ through 1520_(g-1)) to a selected control voltage of a plurality of control voltages V_0 , $V_1(x)$, through $V_{(k-1)}(x)$, where control voltage V_0 is substantially static (substantially non-responsive to the selected parameter “x”, such as temperature), while the remaining control voltages $V_1(x)$ through $V_{(k-1)}(x)$ are generally responsive or sensitive to the selected parameter “x”, such as temperature. As illustrated, the backplates of each corresponding pair of variable capacitors 1515 (A and B) are coupled to each other (shorted together), and then connected via a switch to a selected control voltage. Each such pair of variable capacitances 1515 is switchable, through corresponding coefficients (illustrated as a fourth plurality of coefficients d_0 , d_1 , . . . $d_{(k-1)}$ through h_0 , h_1 , . . . $h_{(k-1)}$, such that each module 1505 may be switched separately and independently to any of the plurality of control voltages V_0 , $V_1(x)$, through $V_{(k-1)}(x)$. As a consequence, these switchable modules may remain coupled to the resonator with the effective impedance (e.g., reactance) varied through switching to one or more control voltages.

[0122] FIG. 23 is a circuit diagram illustrating an exemplary second voltage control module 1600 utilized in a frequency-temperature compensation module in accordance with the teachings of the present invention. As illustrated in FIG. 23, a parameter-sensitive or responsive current source 655 (such as any of the various CTAT, PTAT and PTAT² temperature sensitive current sources, and their combinations, previously discussed and illustrated in FIGS. 7A-7D) is provided (through one or more current mirrors (e.g., 670, 510, 520)) to an array or bank of a plurality “k-1” of resistive modules 1605 (illustrated as modules 1605₀, 1605₁, through 1605_(k-1)), each of which provides a separate or independent control voltage, $V_1(x)$, $V_2(x)$, through $V_{(k-1)}(x)$ which are provided to modules 1505 (of FIG. 22). The various corresponding resistors 1620₀, 1620₁, through 1620_(k-1) may be any of the types, sizes or weights previously discussed with reference to FIG. 10, to provide any selected voltage response to a selected parameter, such as temperature. A static control voltage, V_0 , as illustrated, may be generated utilizing any voltage divider coupled between the voltage supply rail V_{DD} and ground, with corresponding resistance magnitudes or values 1605₀ and 1605_y selected to provide the desired static voltage level. In addition, generation of a plurality of different static or constant (i.e., temperature independent) voltages is illustrated in FIG. 28, by combining different current sources having differently shaped currents in response to temperature (or another parameter) with different temperature-dependent resistors having complementary or opposing temperature responses, resulting in a plurality of control voltages having different magnitudes and substantially constant over temperature

variations. Any of these various voltages may be utilized, as needed, as any of the various control voltages.

[0123] In the exemplary embodiments, each such control voltage of the plurality of control voltages is different, to provide a plurality of control voltages, each of which are differently responsive or shaped (i.e., provide different responses (response curves) as a function of variations in the selected parameter such as temperature), may respond to different parameters, and others which may be substantially constant with respect to a selected parameter. Depending upon the selected embodiment, the array or bank of resistive modules 1605 may be switchable (through corresponding transistors 1610 (illustrated as transistors 1610₀, 1610₁, through 1610_(k-1)), and thereby switched into or out of the array 1600, or may be statically included (fixed connections 1615, illustrated as dashed lines in FIG. 23) to automatically generate a predetermined number of control voltages V_0 , $V_1(x)$, through $V_{(k-1)}(x)$. Depending upon the selection of resistors 1620 (and/or transistors 1610, if included), each of the various control voltages V_0 , $V_1(x)$, through $V_{(k-1)}(x)$ will be different or otherwise provide a different response to the selected parameter or variable, such as a different temperature response.

[0124] Similarly, FIG. 26 is a circuit and block diagram illustrating an exemplary third voltage control module 1900 which may be utilized to provide control voltages to any of the various modules in accordance with the teachings of the present invention. As illustrated in FIG. 26, a plurality of parameter-sensitive or responsive current sources 1955 (such as any of the various CTAT, PTAT and PTAT² temperature sensitive current sources, and their combinations, previously discussed and illustrated in FIGS. 7A-7D) is provided (through one or more current mirrors (e.g., 670, 510, 520)) to an array or bank of a plurality “n-1” of resistive modules 1905 (illustrated as modules 1905₀, 1905₁, through 1905_(n-1)). Each of the resistive modules 1905 provides a separate or independent control voltage, $V_0(P)$, $V_1(P)$, $V_2(P)$, through $V_{(n-1)}(P)$, creating a plurality of control voltages which are responsive or dependent upon the selected parameter “P”, and which are provided to controlled reactance modules 1805, controlled capacitance modules 1505 (of FIG. 22), or any of the other modules utilizing one or more control voltages. The various corresponding resistors 1920₀, 1920₁, through 1920_(n-1) may be any of the types, sizes or weights previously discussed, to provide any selected voltage response to a selected parameter. The selection of current source (or combination of current sources) and resistor size and type allows the shaping of the response of any desired control voltage to the selected parameter. In addition, any of the plurality of different static or constant (i.e., temperature independent) voltages illustrated in FIG. 28 also may be utilized, as needed, as any of the various control voltages for any of the modules discussed.

[0125] Depending upon the selected embodiment, the array or bank of resistive modules 1905 may be switchable (through corresponding transistors 1915 (illustrated as transistors 1915₀, 1915₁, through 1915_(n-1)), and thereby switched into or out of the array, dynamically or statically, to automatically generate a plurality of control voltages $V_0(P)$, $V_1(P)$, $V_2(P)$, through $V_{(n-1)}(P)$. Each of these different control voltages may then be switched (using switches 1930, such as a full crossbar switch), in any combination,

statically or dynamically, under the switching control of control signals and/or coefficients **1950**, to controlled reactance modules **1805**, which may be coupled to the resonator or which also may be switched into or out of the tank. As a consequence, any of these control voltages may be utilized to control the effective reactance of the resonator (oscillator), providing both discrete and continuous control of the resulting resonant frequency. For example, any of these parameter-dependent control voltages $V_0(P)$, $V_1(P)$, $V_2(P)$, through $V_{(n-1)}(P)$, or any of the substantially parameter-independent control voltages (**FIG. 28**), may be provided to the controlled impedance modules **1305** or the controlled capacitance modules **1505** or **1805** to vary the effective capacitance provided to the resonator, providing frequency control over variations from any of a plurality of parameters.

[**0126**] Referring again to **FIG. 22**, when each of these different control voltages V_0 , $V_1(x)$, through $V_{(k-1)}(x)$, or more generally, $V_0(P)$, $V_1(P)$, $V_2(P)$, through $V_{(n-1)}(P)$, and any of the substantially constant control voltages, is available and switchable to the variable capacitances C_v **1515** in the variable capacitance modules **1505** through the fourth plurality of coefficients $d_0, d_1, \dots, d_{(k-1)}$ through $h_0, h_1, \dots, h_{(k-1)}$, a highly flexible, fine-tuned and highly controllable frequency response to the selected parameter (such as temperature) is provided to the resonator **405**, enabling highly accurate frequency control over the resonant frequency f_0 . For example, variable capacitances **1515**_{A(g-1)} and **1515**_{B(g-1)} in module **1505**_(g-1) may be switched to control voltage $V_1(x)$ through parameter h_1 (or a corresponding dynamically applied voltage, as a control signal) being set to a logic high or high voltage with the remaining h parameters of the fourth plurality of parameters set to a logic low or low voltage, providing a first frequency response as a function of temperature or another selected parameter, while variable capacitances **1515**_{A0} and **1515**_{B0} in module **1505**₀ may be switched to control voltage $V_{(k-1)}(x)$ through parameter $d_{(k-1)}$ (or a corresponding dynamically applied voltage, as another control signal) being set to a logic high or high voltage with the remaining d parameters of the fourth plurality of parameters set to a logic low or low voltage, providing a second frequency response as a function of temperature or another selected parameter, and so on. As discussed above, the fourth plurality of coefficients $d_0, d_1, \dots, d_{(k-1)}$ through $h_0, h_1, \dots, h_{(k-1)}$, also may be determined post-fabrication through testing one or more ICs, or may also be determined and varied dynamically during operation of the oscillator, such as through sensor(s) **1440** and A/D converter **1445**, as illustrated in **FIG. 21**, or through sensor(s) **1815** and control logic (or control loop) **1810** illustrated in **FIG. 25**. More generally, such control through either coefficients or control signals is illustrated in **FIG. 26**, and can be utilized to provide either or both discrete or continuous frequency control as a function of any selected parameter, such as temperature, voltage, fabrication process, age, or frequency.

[**0127**] In addition, in lieu of stored coefficients for the first, second or fourth pluralities of coefficients, particularly when the corresponding values would be determined dynamically, as discussed above, corresponding voltages may be directly applied to the various switches (e.g., transistors **1520** or the switching transistors of modules **640** and **650**), as control signals, as mentioned above.

[**0128**] Referring again to **FIG. 4**, another compensation module is also utilized to provide greater control and accuracy over the resonant frequency f_0 , also for applications in which greater accuracy and less variance (or frequency drift) may be required, such as to provide a frequency accuracy of approximately $\pm 0.25\%$ or better over PVT. In these circumstances, a process variation compensation module **425** may be utilized, to provide control over the resonant frequency f_0 independently of fabrication process variations, such as the exemplary modules illustrated in **FIGS. 11 and 12**. As indicated above, any of these various modules may include any impedance, reactance, or resistance, and be made responsive to any selected parameter, such as temperature, process variation, voltage variation, and frequency variation.

[**0129**] **FIG. 11** is a circuit diagram illustrating an exemplary first process variation compensation module **760** in accordance with the teachings of the present invention. The first process variation compensation module **760** may be utilized as the process compensation modules **460** in **FIG. 4**, with each module attached to a rail or side of the resonant LC tank **405** (lines or nodes **470** and **475**). In addition, each first process variation compensation module **760** is controlled by a third plurality ("y") of switching coefficients r_0 through $r_{(y-1)}$, stored in register **465**. The first process variation compensation module **760** provides an array of switchable capacitive modules having differentially-weighted (e.g., binary-weighted), first fixed capacitances **750**, for adjustment and selection of the resonant frequency f_0 , by switching in or out a plurality of fixed capacitances **750**, through a corresponding plurality of switching transistors **740** (controlled by a corresponding "r" coefficient). Again, as each capacitance branch is switched in or out of the array or circuit **760**, the corresponding first fixed capacitance is added or subtracted from the total capacitance available for oscillation in the resonant LC tank, thereby changing the effective reactance and modulating the resonant frequency. The third plurality of switching coefficients r_0 through $r_{(y-1)}$ is also determined post-fabrication using test ICs, generally as an iterative process with the determinations of the first and second (or fourth) pluralities of switching coefficients. This calibration is accomplished using the frequency calibration module (**325** or **430**) and a reference oscillator known to have a predetermined frequency. The determined "r" coefficients are then stored in the corresponding registers **465** of the ICs of that production or process batch. Alternatively, each IC may be calibrated separately, for example.

[**0130**] In addition to such calibration methods, the third plurality of switching coefficients r_0 through $r_{(y-1)}$ may also be determined using other methods, discussed below, such as using various voltage and current sensors to measure parameters or variables which reflect fabrication process parameters, such as transistor threshold voltages, resistance magnitudes or values of the tank, or absolute current levels produced by the various current sources. Such measured values may then be utilized to provide corresponding coefficients (the third plurality of switching coefficients r_0 through $r_{(y-1)}$) and/or control signals for corresponding frequency adjustment. For example, such measured or sensed values may be converted to digital values, which are then indexed to a lookup table in memory, which then provides stored values based on known values, or other calibrations or modeling.

[0131] To avoid additional frequency distortions, several additional features may be implemented with this first process variation compensation module 760. First, to avoid additional frequency distortion, the on resistance of the MOS transistors 740 should be small, and therefore the transistors' width/length ratio is large. Second, large capacitances may be split into two branches, with two corresponding transistors 740 controlled by the same "r" coefficient. Third, to provide for the resonant LC tank to have a similar load under all conditions, when a first fixed capacitance 750 is switched in or out of the circuit 760, a corresponding second fixed capacitance 720, as a "dummy" capacitor (having a significantly smaller capacitance or the smallest size allowed by the design rules for the fabrication process), is correspondingly switched out of or into the circuit, based on the inverse of the corresponding "r" coefficient. As a consequence, approximately or substantially the same on resistance of the transistors 740 is always present, with only the amount of capacitance varied.

[0132] As an alternative to the use of the "dummy" capacitances, metal fuses or the like could be utilized instead of the transistors 740. Metal fuses would be left intact to include the corresponding fixed capacitance 750, and could be "blown" (open-circuited) to remove the corresponding fixed capacitance 750 from the resonant LC tank 405.

[0133] FIG. 12 is a circuit diagram illustrating an exemplary second process variation compensation module 860 in accordance with the teachings of the present invention. The second process variation compensation module 860 may be utilized as the process compensation modules 460 in FIG. 4, with each module attached to a rail or side (lines 470 and 475) of the resonant LC tank 405, instead of modules 760. More generally, the second process variation compensation module 860 is utilized as part of frequency controller (215, 349 or 1415), such as process (or other parameter) modulator or compensator 1430 (FIG. 21). In addition, each second process variation compensation module 760 would also be controlled by a third plurality of switching coefficients r_0 through $r_{(y-1)}$, stored in register 465. (Because of the different circuitry employed in each exemplary process variation compensation module 760 or 860, however, the corresponding third pluralities of switching coefficients r_0 through $r_{(y-1)}$ generally would, of course, be different from each other.) In addition, such switching may be controlled through use of any control signals, discussed above.

[0134] It should be noted that FIG. 12 provides a varactor illustration different from those utilized in other Figures, in which a varactor 850 is represented by a MOS transistor, rather than as a capacitor with an arrow through it. Those of skill in the art will recognize that varactors are often AMOS or IMOS transistors, or more generally MOS transistors, such as those illustrated in FIG. 12, and configured by shorting the transistor's source and drain. As a consequence, the other illustrated varactors may be considered to include, as potential embodiments, the AMOS or IMOS transistors as configured as in FIG. 12. In addition, the varactors 850 may also be binary-weighted with respect to each other, or may use another differential weighting scheme.

[0135] The second process variation compensation module 860 has a similar structural concept, but additional notable differences from the first process variation compensation module 760. The second process variation compen-

sation module 860 provides an array or bank of a plurality of switchable variable capacitive modules 865, without MOS switches/transistors, and hence the losses or loading through the MOS transistors are eliminated. Instead, the load appears as a low loss capacitance; such low loss also implies that the oscillator start-up power is less. In the second process variation compensation module 860, a MOS varactor 850 is switched either to V_{in} , which may be any of the various pluralities of control voltages discussed above, to provide a corresponding capacitance level to the resonant LC tank 405, or may be switched to ground or the power rail (voltage V_{DD}), thereby providing either the minimum capacitance or the maximum capacitance to the resonant LC tank 405 based upon the varactor 850 geometry. For AMOS, switched to voltage V_{DD} would provide minimum capacitance and switched to ground would provide maximum capacitance, while the opposite is the case for IMOS. Again, the second process variation compensation module 860 is comprised of an array of variable capacitances, as varactors 850, for adjustment and selection of the resonant frequency f_0 , by coupling or switching a selected varactor 850 to any of a plurality of control voltages (V_{in}), or to ground or V_{DD} , such as switching between a first voltage and a second voltage, through a corresponding "r" coefficient or through application of a corresponding control signal. In another alternative, instead of a plurality or an array, one varactor 850 may be utilized, with its effective reactance provided to the tank controlled by a selected control voltage.

[0136] As each capacitance branch is switched to a corresponding control voltage, ground or V_{DD} , the corresponding variable capacitance is added to or not included in the total capacitance available for oscillation in the resonant LC tank, thereby changing its effective reactance and modulating the resonant frequency. More particularly, for an AMOS implementation, coupling to V_{DD} (as V_{in}) provides lesser capacitance and coupling to ground ($V_{in}=0$) provides greater capacitance, with the opposite holding for an IMOS implementation, in which coupling to V_{DD} (as V_{in}) provides greater capacitance and coupling to ground ($V_{in}=0$) provides lesser capacitance, where it is assumed that the voltage on the rails of the LC tank (nodes or lines 470 and 475 of FIG. 4) is between zero V and voltage V_{DD} , and significantly or substantially far from either voltage level. Coupling to voltages between V_{DD} and ground, such as many of the various control voltages, as V_{in} , will provide a corresponding, intermediate level of capacitance to the tank. The third plurality of switching coefficients r_0 through $r_{(y-1)}$ is also determined post-fabrication using test ICs, also generally as an iterative process with the determinations of the first and second pluralities of switching coefficients. The determined "r" coefficients are then stored in the corresponding registers 465 of the ICs of that production or process batch. Again, individual ICs may also be calibrated and tested separately. In addition, any selected number of modules 850 may be controlled dynamically, to provide continuous frequency control during oscillator operation.

[0137] As indicated above, depending upon the type (AMOS or IMOS) of varactor, switching any of the variable capacitive modules 865 to VDD or ground, as first and second voltage levels, results in the corresponding maximum capacitance or no (negligible) capacitance being included as effective capacitance for the resonator (LC tank). As mentioned above, however, other capacitance levels intermediate between such maxima and minima may also be

generated, by switching the variable capacitive modules **865** to a corresponding control voltage. Utilizing a plurality of control voltages having different magnitudes, results in a corresponding capacitance of the variable capacitive modules **865** being added to (or subtracted from) the LC tank, thus changing its effective reactance and modulating the resonant frequency.

[0138] **FIG. 28** is a circuit diagram illustrating an exemplary fourth voltage control module **2050** utilized in frequency, process and other parameter compensation modules in accordance with the teachings of the present invention. Referring to **FIG. 28**, a plurality of substantially constant voltage modules **2060** (illustrated as **2060_A**, **2060_B**, **2060_C** through **2060_K**) are utilized to create a corresponding plurality of control voltages which are substantially constant with respect to a selected parameter, such as temperature, and which have a corresponding plurality of different magnitudes, creating a plurality of control voltages V_A , V_B , V_C through V_K , which have different magnitudes. As illustrated, the plurality of different, substantially static or constant (i.e., temperature independent) voltages is created by combining different current sources **2055** (illustrated as current sources **2055_A**, **2055_B**, **2055_C** through **2055_K**), each having different responses to temperature or another parameter (i.e., differently shaped currents in response to temperature (or another parameter)), with a corresponding plurality of resistors **2040** (illustrated as corresponding resistors **2040_A**, **2040_B**, **2040_C** through **2040_K**), each of which have a temperature or other parameter-dependent response which is opposing or complementary to the corresponding current source **2055** of the particular module **2060**. Each corresponding current source **2055** and resistor **2040** is selected to have such opposing or complementary responses with the other, to effectively cancel the other's response to the selected parameter. For example, a current source **2055** is selected to have a particular combination of PTAT, CTAT or CTAT² current sources of appropriate magnitude, and a resistor **2040** is selected based on size, type, and so on, such that the resulting voltage is substantially constant over the parameter variations, e.g., temperature variations. Any of these various voltages may be utilized, as needed, as any of the various control voltages, such as to provide a corresponding V_{in} for the variable capacitive modules **865** illustrated in **FIG. 12**, to adjust the effective capacitance (reactance) of the resonator and the resulting resonant frequency.

[0139] It should also be noted that the illustrated embodiments for modules such as temperature compensator **315** (or **410**, **415** and/or **420**) and process variation compensator **320** (or **425** and **460**), such as those illustrated in **FIGS. 6-12**, may be utilized for other purposes. For example, the various illustrated embodiments for the compensator **315** (or **410**, **415** and/or **420**) may be made dependent upon process variation, rather than temperature. Similarly, the various illustrated embodiments for the compensator **320** (or **425** and **460**) may be made dependent upon temperature, rather than process variation. As a consequence, the embodiments for these and other modules should not be considered limited to the exemplary circuits and structures illustrated, as those of skill in the art will recognize additional and equivalent circuits and applications, all of which are within the scope of the invention.

[0140] As indicated above, the various illustrated controlled capacitance modules (**485**, **635**, **460**, **760**, **860**, **1501**)

may be generalized to any reactance or impedance element, whether a capacitance, inductance, resistance, or combination of capacitance, inductance or resistance. An array or bank **1300** of such a plurality ("a") of switchable, controlled impedance (or reactance) modules **1305** are illustrated in **FIG. 20**, and may be utilized within the frequency controller (**215**, **349**, **1400**) of the present invention, as any of the various modulators or compensators (**315**, **320**, **355**, **1420**, **1425**, **1430**). Each differently weighted, controlled reactance or impedance module **1305** (illustrated as **1305₀**, **1305₁**, through **1305_(a-1)**) is comprised of one or more fixed reactances Z_f **1315**, variable reactances Z_v **1310**, or "dummy" reactances **1320**, which are switchable in response to a corresponding coefficient "s" of a fifth plurality of coefficients (s_0 , s_1 , through $s_{(a-1)}$). The array of controlled reactance or impedance modules **1305** generally may be implemented to operate as discussed above with respect to any of the various controlled capacitance modules, in any of the various embodiments. The fifth plurality of coefficients may be determined post-fabrication, or dynamically, as discussed above for the other sets of coefficients. In addition, depending upon the implementation, the various reactances or impedances may be switched in or out of the array **1300** or switched to various control voltages or ground, as previously illustrated, and may be utilized to provide a selected frequency response of the oscillator in response to any of a plurality of parameters, such as temperature variations, voltage fluctuations, fabrication process, or frequency.

[0141] Similarly, referring to **FIG. 25**, an array or bank of a plurality "n" of switchable, controlled reactance modules **1805** are illustrated (as controlled reactance modules **1805₀** through **1805_(n-1)**), and also may be utilized within the frequency controller (**215**, **1415**) of the present invention, as any of the various modulators or compensators (**315**, **320**, **355**, **1420**, **1425**, **1430**). These controlled reactance modules **1805** may also be binary, linearly, or otherwise differently weighted, and switched in or out of the various circuits, switched to one or more control voltages, or any combination thereof, and may be responsive to any selected parameter. The array of controlled reactance modules **1805** generally may be implemented to operate as discussed above with respect to any of the various controlled capacitance modules, in any of the various embodiments. Rather than being switched to the oscillator through a plurality of coefficients, in this exemplary embodiment, the controlled reactance modules **1805** are switched dynamically, through voltages or currents provided directly by sensors **1815** and control logic **1810**, with feedback provided (line or node **1820**), and which may be implemented as known in the art, or as illustrated above, with all such variations considered within the scope of the present invention. In addition, the reactance modules may be more considered more broadly, as impedance modules, with both a resistive and/or reactance aspect, such as utilizing the various resistors illustrated in **FIG. 29**.

[0142] For example, such variations in the selected parameter may be determined in any of a plurality of ways previously discussed, such as through a temperature-sensitive current source, other temperature sensors, or any other type of sensor which is responsive to the selected parameter. For example, a sensor may comprise a voltage across a diode, providing a voltage output responsive to temperature. Referring to **FIG. 21**, the output of such a sensor **1440** may be provided to A/D converter **1445**, which provides a digital

output indicative of the level of the sensed parameter, which may then be utilized as the corresponding coefficients (any of the pluralities of coefficients discussed above), or utilized to dynamically switch any of the various controlled reactance or impedance modules (e.g., **1305**, **1805**) or the various second controlled capacitance modules. Similarly, sensor **1815** output may be provided to control logic **1810**, which may also adjust the various reactances, either statically or dynamically, and with or without feedback from the resonator.

[0143] **FIG. 27** is a circuit and block diagram illustrating an exemplary voltage variation compensation module **2000** in accordance with the teachings of the present invention, and may be utilized as a voltage variation compensator **380**, **1455** illustrated in **FIGS. 3 and 21**. Referring to **FIG. 27**, a switchable resistive module **1650** forms a voltage divider, using resistors **1620_o** and **1620_y**, providing voltage V_o . In the event of fluctuations in the supply voltage (power rail) V_{DD} , voltage V_o is correspondingly changed. As voltage V_o can be switched (switches **1930**) (as discussed above) to any of the controlled reactance modules **1805**, under the control of control signals or coefficients **1950**, the effective capacitance to the tank is also varied, thereby modulating the resonant frequency. As a result, the resonant frequency may be controlled over such voltage fluctuations. Other implementations will be apparent based upon the other illustrated embodiments, and are also within the scope of the invention.

[0144] As indicated above, the resonant frequency of the tank may also be modified by varying the resistance to the tank, in addition to the intrinsic or parasitic resistances R_L **445** and R_C **450** of **FIG. 4**. **FIG. 29** is a circuit diagram illustrating an exemplary resistive control module **2100** which may be utilized as or as part of any of the various frequency control module and the various frequency controllers in accordance with the teachings of the present invention. Such a resistive control module **2100** may be inserted into node Q in resonator **405** of **FIG. 4**, in series with inductor **435** and R_L **445**, or in series with capacitor **440** and R_C **450**, or both. Each switchable resistive module **2115** (illustrated as the plurality of switchable resistive modules **2115_M**, **2115_N**, **2115_O** through **2115_T**) has a differently weighted (such as a binary-weighted), resistor **2105** (illustrated as corresponding resistors **2105_M**, **2105_N**, **2105_O** through **2105_T**), and is switchable in or out of the array or module **2100** through corresponding transistors or switches **2110** (illustrated as transistors **2110_M**, **2110_N**, **2110_O** through **2110_T**), under the control of control signals and/or coefficients **1950**. As indicated above, such switching also provides another mechanism to control or modulate the resonant frequency of the resonator **405**, and may be a function of any selected parameter, or may be parameter independent, such as for resonant frequency selection.

[0145] **FIG. 30** is a block diagram illustrating an exemplary age variation compensator **2200** in accordance with the teachings of the present invention. As illustrated in **FIG. 30**, various sensors are utilized to measure a relevant parameter which is or may be affected by the passage of time, or which otherwise changes over the lifetime of an IC, such as a voltage sensor **2205** to measure a threshold voltage of a transistor, a resistance sensor **2210** to measure one or more resistance magnitudes or values of the tank, and/or a current sensor to measure absolute current levels produced by the various current sources. A selected measurement, at a given

point in time is provided (via multiplexer **2220**) to ADC **2225**, for conversion into a digital value, which is stored in a register or other non-volatile memory **2230**. When the IC is first powered on or otherwise initialized, an initial measurement is stored in the register **2230**, to provide a basis for comparison for subsequent measurements. Subsequently, additional measurements may be performed, with the resulting values stored as corresponding current values in register **2230**, illustrated as current and initial values for voltage, resistance and current. For a given parameter, such as voltage, current and initial values may be read and compared, comparator **2235**, which then provides a corresponding age compensation signal proportional to any difference between the two values. Such difference values provided by the age compensation signal may then be utilized to provide corresponding coefficients and/or control signals for corresponding frequency adjustment. For example, such age compensation signals may be indexed to a lookup table in memory **2240**, which then provides stored values based on known values, or other calibrations or modeling of age affects, and provides for corresponding frequency adjustments using any of the various modulators and compensators discussed above.

[0146] Referring again to **FIG. 21**, the frequency controller **215**, **349**, **1415** of the present invention may comprise one or more of the following components: (1) a transconductance modulator **1410** (e.g. **410**, **415** and the embodiments illustrated in **FIGS. 6-8**), which in the exemplary embodiments, may also include or be coupled to sustaining amplifier **305**; (2) a variable parameter modulator **1425**, to modulate the resonant frequency f_o in response to any selected parameter, such as temperature, fabrication process variation, voltage variation, or frequency, such as the various controlled capacitance modules **485**, **635**, **1505** or controlled reactance modules **1305**, **1805**; (3) a process (or other parameter) modulator or compensator **1430**, such as process variation compensator **425**, **760**, **860**, or controlled reactance modules **1305**, **1805**; (4) a voltage variation compensator **380**, **1455**; and/or (5) an age (time) variation compensator (or modulator) **365**, **1460**. It will be observed by those of skill in the art that the various divisions between transconductance modulator **1410**, variable parameter modulator **1425**, or process (or other parameter) modulator or compensator **1430** or the other compensators and modulators are arbitrary and do not limit the scope of the present invention, as each may be made responsive to any of the parameters discussed above, and each may be utilized for any of the purposes discussed above (e.g., the variable parameter modulator **1425** may be utilized to compensate for fabrication process variations, etc., rather than temperature variations, for example). In addition, depending upon the selected implementation, one or more coefficient registers **1435** (e.g., **455**, **465**, **495**) may be utilized to store any of the pluralities of coefficients discussed above. In alternative embodiments, such coefficients may not be needed, with switching voltages or currents applied directly, either statically or dynamically, as control signals.

[0147] Also in the exemplary embodiments, these various components may include a sensor **1440**, **1815** (e.g., $yI(x)$ or $I(T)$) generator **415**, **515**), or such as sensor may be provided as a separate component, such as a current source coupled to a diode as discussed above. Also, depending on the selected embodiment, and A/D converter **1445** and control logic **1450**, **1810**, to provide the selected frequency control.

[0148] In summary, the exemplary embodiments of the present invention provide an apparatus for frequency control of a resonator, with the resonator adapted to provide a first signal having a resonant frequency. The apparatus comprises a sensor (1440, 1815) adapted to provide a second signal, such as a control voltage, in response to at least one parameter of a plurality of parameters; and a frequency controller (215, 1415) coupled to the sensor and coupleable to the resonator, with the frequency controller adapted to modify the resonant frequency in response to the second signal. The plurality of parameters are variable and comprise at least one of the following parameters: temperature, fabrication process, voltage, frequency, and age.

[0149] In the exemplary embodiments, the frequency controller is further adapted to modify a reactance or impedance element coupled to the resonator in response to the second signal, such as modifying a total capacitance of the resonator in response to the second signal (FIG. 9), coupling to the resonator or decoupling from the resonator a fixed or variable capacitance (635), modifying the effective reactance of a varactor coupled to the resonator by switching the varactor to a selected control voltage, or equivalently, modifying an inductance of the resonator in response to the second signal, such as by coupling to the resonator or decoupling from the resonator a fixed or variable inductance, or modifying a resistance (or other impedance) of the resonator in response to the second signal, such as by coupling to the resonator or decoupling from the resonator a resistance.

[0150] In the exemplary embodiments, the frequency controller may further comprise: a coefficient register adapted to store a first plurality of coefficients; and a first array (635) having a plurality of switchable capacitive modules coupled to the coefficient register and coupleable to the resonator, each switchable capacitive module having a fixed capacitance 615 and a variable capacitance 620, each switchable capacitive module responsive to a corresponding coefficient of the first plurality of coefficients to switch between the fixed capacitance and the variable capacitance and to switch each variable capacitance to a control voltage. The plurality of switchable capacitive modules may be binary-weighted. The frequency controller may further comprise a second array 650 having a plurality of switchable resistive modules coupled to the coefficient register and further having a capacitive module, the capacitive module and the plurality of switchable resistive modules further coupled to a node 625 to provide the control voltage, with each switchable resistive module responsive to a corresponding coefficient of a second plurality of coefficients stored in the coefficient register to switch the switchable resistive module to the control voltage node 625. In selected embodiments, the sensor further comprises a current source 655 responsive to temperature, wherein the current source is coupled through a current mirror 670 to the second array to generate the control voltage across at least one switchable resistive module of the plurality of switchable resistive modules. Also in selected embodiments, the current source has at least one CTAT, PTAT, or PTAT² configuration (FIGS. 7A-7D). In addition, each switchable resistive module of the plurality of switchable resistive modules has a different temperature response for a selected current.

[0151] In other exemplary embodiments, the sensor is a temperature sensor and varies the second signal in response to temperature variation. The selected embodiments may

also include an analog-to-digital converter 1445 coupled to the temperature sensor to provide a digital output signal in response to the second signal, and a control logic block 1450 to convert the digital output signal to the first plurality of coefficients.

[0152] In other exemplary embodiments, the frequency controller further comprises a process variation compensator 320, 425, 760 or 860, the process variation compensator coupleable to the resonator and adapted to modify the resonant frequency in response to a fabrication process parameter of the plurality of parameters. The process variation compensator may further comprise a coefficient register adapted to store a plurality of coefficients; and an array 760 having a plurality of switchable capacitive modules coupled to the coefficient register and to the resonator, each switchable capacitive module having a first fixed capacitance 750 and a second fixed capacitance 720, each switchable capacitive module responsive to a corresponding coefficient of the plurality of coefficients to switch between the first fixed capacitance and the second fixed capacitance. In other exemplary embodiments, the process variation compensator may further comprise a coefficient register adapted to store a plurality of coefficients; and an array 860 having a plurality of binary-weighted switchable variable capacitive modules 865 coupled to the coefficient register and to the resonator, each switchable variable capacitive module responsive to a corresponding coefficient of the plurality of coefficients to switch between a first voltage and a second voltage.

[0153] In other exemplary embodiments, a frequency controller further comprises a coefficient register adapted to store a first plurality of coefficients; and a first array 1500 having a plurality of switchable, binary-weighted capacitive modules 1505 coupled to the coefficient register and coupleable to the resonator, each switchable capacitive module having a variable capacitance 1515, each switchable capacitive module responsive to a corresponding coefficient of the first plurality of coefficients to switch (1520) the variable capacitance to a selected control voltage of a plurality of control voltages. The sensor may comprise a current source responsive to temperature, and the frequency controller may also include a second array 1600 having a plurality of resistive modules 1605 coupled through a current mirror (670, 510, 520) to the current source (655), the plurality of resistive modules adapted to provide the plurality of control voltages, and wherein each resistive module of the plurality of resistive modules has a different response to temperature and is adapted to provide a corresponding control voltage, of the plurality of control voltages, in response to a current from the current source.

[0154] In other exemplary embodiments, an apparatus for frequency control of a resonator comprises a coefficient register adapted to store a first plurality of coefficients; and a first array (1300, 1800) having a plurality of switchable reactance modules (1305, 1805) coupled to the coefficient register and to the resonator, each switchable reactance module responsive to a corresponding coefficient of the first plurality of coefficients to switch a corresponding reactance to the resonator to modify the resonant frequency. The corresponding reactance may be a fixed or variable inductance, a fixed or variable capacitance, or any combination thereof. The corresponding reactance may be switched between the resonator and a control voltage or a ground potential, and the control voltage may be determined by a

current source responsive to temperature. For example, the corresponding reactance is variable and is switched between the resonator and a selected control voltage of a plurality of control voltages. In selected embodiments, the first plurality of coefficients are calibrated or are determined by a sensor responsive to at least one parameter of a plurality of variable parameters, such as temperature, fabrication process, voltage, and frequency.

[0155] In the exemplary embodiments, the plurality of switchable reactance modules may further comprise a plurality (635) of binary-weighted switchable capacitive modules 640, each switchable capacitive module having a fixed capacitance and a variable capacitance, each switchable capacitive module responsive to a corresponding coefficient of the first plurality of coefficients to switch between the fixed capacitance and the variable capacitance and to switch each variable capacitance to a control voltage. The apparatus may also include a current source 655 responsive to temperature; and a second array having a plurality of switchable resistive modules 675 coupled to the coefficient register and selectively coupleable to the current source, the second array further having a capacitive module 680, the capacitive module and the plurality of switchable resistive modules further coupled to a node 625 to provide the control voltage, each switchable resistive module responsive to a corresponding coefficient of a second plurality of coefficients stored in the coefficient register to switch the switchable resistive module to the control voltage node, and wherein each switchable resistive module of the plurality of switchable resistive modules has a different temperature response for a selected current from the current source.

[0156] In other exemplary embodiments, the plurality of switchable reactance modules further comprise a plurality 1500 of binary-weighted switchable capacitive modules 1505, each switchable capacitive module having a variable capacitance 1515, each switchable capacitive module responsive to a corresponding coefficient of the first plurality of coefficients to switch (1520) the variable capacitance to a selected control voltage of a plurality of control voltages. The apparatus may also include a current source 655 responsive to temperature; and a second array having a plurality of resistive modules 1605 coupled through a current mirror (670, 510, 520) to the current source, the plurality of resistive modules adapted to provide the plurality of control voltages, and wherein each resistive module of the plurality of resistive modules has a different response to temperature and is adapted to provide a corresponding control voltage, of the plurality of control voltages, in response to a current from the current source.

[0157] In other exemplary embodiments, the plurality of switchable reactance modules may further comprise a plurality 760 of binary-weighted switchable capacitive modules coupled to the coefficient register and to the resonator, each switchable capacitive module having a first fixed capacitance 750 and a second fixed capacitance 720, each switchable capacitive module responsive to a corresponding coefficient of the plurality of coefficients to switch between the first fixed capacitance and the second fixed capacitance. In other exemplary embodiments, the plurality of switchable reactance modules may further comprise a plurality 860 of binary-weighted switchable variable capacitive modules 865 coupled to the coefficient register and to the resonator, each switchable variable capacitive module responsive to a cor-

responding coefficient of the plurality of coefficients to switch between a first voltage and a second voltage.

[0158] In the exemplary embodiments, an apparatus in accordance with the teachings of the invention comprises a resonator 310, 405 adapted to provide a first signal having a resonant frequency; and a temperature compensator 315 coupled to the resonator and adapted to modify the resonant frequency in response to temperature variation. The resonator is at least one of the following resonators: an inductor (L) and a capacitor (C) configured to form an LC-tank resonator; a ceramic resonator, a mechanical resonator, a microelectromechanical resonator, or a film bulk acoustic resonator. The apparatus may further comprise a negative transconductance amplifier 410 coupled to the resonator and to the temperature compensator, wherein the temperature compensator is further adapted to modify a current through the negative transconductance amplifier in response to temperature variation. The temperature compensator may further comprise a current source 415, 515, 655 responsive to temperature variation.

[0159] In other exemplary embodiments, the temperature compensator further comprises: a current source 415, 515, 655 adapted to provide a current responsive to temperature variation; a coefficient register adapted to store a first plurality of coefficients; a plurality of resistive modules 675, 1605 coupled to the resonator and the current source, at least one resistive module of the plurality of resistive modules adapted to provide a control voltage or a plurality of control voltages; and a plurality of switchable reactance modules (1305, 1805, 635, 1505), coupled to the resonator and to the current source and selectively coupleable to at least one resistive module of the plurality of resistive modules.

[0160] In other exemplary embodiments, the invention provides a frequency controller for frequency control of a resonator, comprising: a coefficient register adapted to store a first plurality of coefficients and a second plurality of coefficients; a current source 415, 515, 655 adapted to provide a current corresponding to a temperature; a first array having a plurality of switchable resistive modules 675, 1605 coupled to the coefficient register and further having a capacitive module, the first array further coupled through a current mirror to the current source to create at least one control voltage across at least one switchable resistive module of the plurality of switchable resistive modules, each switchable resistive module responsive to a corresponding coefficient of the second plurality of coefficients to switch the switchable resistive module to provide the control voltage to a control voltage node; and a second array having a plurality of binary-weighted switchable capacitive modules 640 coupled to the coefficient register and to the resonator, each switchable capacitive module having a fixed capacitance and a variable capacitance, each switchable capacitive module responsive to a corresponding coefficient of the first plurality of coefficients to switch between the fixed capacitance and the variable capacitance and to switch each variable capacitance to the control voltage node.

[0161] Referring again to FIGS. 3 and 4, the clock generator and/or timing/frequency reference (100, 200, or 300) may also include a frequency calibration module (325 or 430). This frequency calibration module is the subject of a separate patent application, but its high-level functionality is described briefly below. FIG. 13 is a high-level block

diagram illustrating an exemplary frequency calibration module **900** (which may be utilized as module **325** or **430**) in accordance with the teachings of the present invention. The frequency calibration module **900** includes a digital frequency divider **910**, a counter-based frequency detector **915**, a digital pulse counter **905**, and a calibration register **930** (which also may be utilized as register **465**). Using a test IC, the output signal from the clock generator (**100**, **200** or **300**) is frequency divided (**910**) and compared with a known reference frequency **920** in frequency detector **915**. Depending upon whether the clock generator (**100**, **200** or **300**) is fast or slow with respect to the reference, down or up pulses are provided to the pulse counter **905**. Based upon those results, the third plurality of switching coefficients r_0 through $r_{(y-1)}$ is determined, and the clock generator (**100**, **200** or **300**) is calibrated to a selected reference frequency. Again, individual ICs may also be calibrated and tested separately.

[0162] Referring again to **FIGS. 2, 3** and **4**, it will be appreciated by those of skill in the art that a highly accurate over PVT, low jitter, free-running and self-referenced oscillator has been described, providing a differential, substantially sinusoidal signal having a selectable and tunable resonant frequency, f_0 , available at nodes **470** and **475**. For many applications, this signal is sufficient, and may be utilized directly (and may be output on bus **125** or **135** of **FIG. 1**, on line **250** of **FIG. 2**, or on line **350** of **FIG. 3**, or between the rails or lines **470** and **475** of **FIG. 4**). For example, this signal may be utilized as a timing or frequency reference. In accordance with the present invention, additional applications are available, including clock generation (substantially square wave), frequency division, low-latency frequency switching, and mode selection, as described below.

[0163] **FIG. 14** is a block diagram illustrating an exemplary frequency divider and square wave generator **1000**, and an exemplary asynchronous frequency selector **1050**, with exemplary glitch suppression module **1080** in accordance with the teachings of the present invention. As indicated above, frequency divider and square wave generator **1000** may be included in or comprise modules **220** and/or **330**, and frequency selector **1050** (with or without glitch suppression module **1080**) may be included in or comprise modules **205** and/or **335**.

[0164] Referring to **FIG. 14**, the output signal from the oscillator, namely, a differential and substantially sinusoidal signal having a frequency f_0 , such as output on line **250** of **FIG. 2**, or line **350** of **FIG. 3**, or between the rails or lines **470** and **475** of **FIG. 4**, is input into frequency divider and square wave generator **1000**. The frequency of this substantially sinusoidal signal is divided by any one or more arbitrary values “N” into “m” different frequencies (including f_0 , where appropriate), and converted to substantially square wave signals, resulting in a plurality of substantially square wave signals having m+1 different available frequencies, output on lines or bus **1020** as frequencies $f_0, f_1, f_2,$ through f_m . Any of these substantially square wave signals having m+1 different available frequencies are selectable asynchronously through exemplary asynchronous frequency selector **1050** which, as illustrated, may be embodied as a multiplexer. The selection of any of these substantially square wave signals having m+1 different available frequencies may be accomplished through the plurality of selection

lines (S_m through S_0) **1055**, providing a substantially square wave signal having the selected frequency, output on line **1060**.

[0165] As part of asynchronous frequency selection, glitch suppression is also provided by glitch suppression module **1080**, which may be embodied in a plurality of ways, including through the use of one or more exemplary D flip-flops (“DFFs”) illustrated in **FIG. 14**. A glitch could occur in an asynchronous frequency transition in which either a low state or a high state is not maintained for a sufficient period of time and may cause metastability in circuitry which is driven by the output clock signal. For example, an asynchronous frequency transition could result in a low state at a first frequency transitioning into a high state at a second frequency, at a point where the high state is about to transition back to a low state at the second frequency, resulting in a voltage spike or glitch. To avoid potential glitches from being provided as part of an output clock signal, the selected substantially square wave signal (having the selected frequency) is provided on line **1060** to a first DFF **1065** which provides a holding state; if a glitch should occur, it will be held until a clock edge triggering the DFF. To avoid the glitch occurring at the clock edge, the DFFs may be clocked at less than the maximum available frequency, or one or more additional DFFs (such as DFF **1070**) may be employed, as during the wait for another clock signal, the Q output from the DFF **1065** will have stabilized to either a first state (high or low) or a second state (low or high), such as to either the power or ground rail. It has been shown by the inventors that 2 DFFs are sufficient, with additional DFFs potentially being added as may be desired, but with additional DFFs causing increased switching latency. While illustrated utilizing exemplary DFFs, other flip-flops or counters may be utilized, and those of skill in the art will recognize myriad other equivalent implementations which will achieve this result, and all such variations are within the scope of the invention.

[0166] Such exemplary low latency frequency switching in accordance with the teachings of the present invention is illustrated in **FIG. 15**. **FIG. 15** is also illustrative of “substantially” square waves of the present invention, which are typical of actual square waves utilized in various technologies, exhibiting reasonable variation, undershoots and overshoots at their respective high and low states (and not the perfect “flatness” of textbook examples). **FIG. 15**, part A, illustrates asynchronous glitch-free switching from 1 MHz to 33 MHz, while part B illustrates measured glitch-free switching from 4 MHz to 8 MHz, then to 16 MHz, and then to 33 MHz.

[0167] Referring again to **FIG. 14**, the frequency divider and square wave generator **1000** may be implemented in innumerable ways, such as differential or single-ended, with the illustrated divider being merely exemplary. As the output from the oscillator illustrated in **FIG. 4** is differential (across lines or rails **470** and **475**), the first divider **1005** is also differential and provides complementary outputs, to present a substantially constant load to the oscillator and to maintain phase alignment, and is fast, to support high frequencies such as in the GHz range. In addition, it may be necessary or advisable to reject any relaxation mode oscillation of the first divider **1005**. The second divider **1010** may also be differential and provide any arbitrary frequency division (divide by “M”), such as dividing by an integer, a multiple

of two, a rational number, or any other amount or number, etc. Topologies or configuration for such dividers are known in the art, and any such divider may be utilized. Such dividers, for example and without limitation, may be a sequence (multiple stages) of counters or flip-flops **1075**, such as those flip-flops illustrated in **FIG. 16**, which provide frequency division in powers or multiples of **2**, with the output of each stage providing a different frequency and further providing a clock signal for the next stage and also fed back to its own input, as illustrated. As illustrated, a plurality of frequencies are then available for output on lines or bus **1020**, such as $f_0/2$, $f_0/4$, and so on, through $f_0/2N$. In addition, as illustrated, buffers **1085** may also be utilized, from the oscillator to the first divider **1005**, to provide sufficient voltage to drive the first divider **1005**, and also between second divider **1010** stages, to isolate state-dependent load variation which could also affect signal rise and fall times.

[**0168**] It should also be noted that the use of the various flip-flops has also provided a substantially square wave, as any substantially sinusoidal signal has been provided to clock a flip flop, whose output is then pulled to a high or low voltage. Other square wave generators may also be utilized, as known or becomes known in the art. In the illustrated embodiments, to maintain phase alignment, differential signals are maintained through the last division. Following the last frequency division, the plurality of signals (each having a different frequency) are then squared (in module **1015**) to provide substantially an evenly divided (e.g., 50:50) duty cycle, such that the time in which the signal is in a first (high) state is substantially equal to the time in which the signal is in a second (low) state.

[**0169**] **FIG. 17** is a block diagram illustrating an exemplary mode selection module in accordance with the teachings of the present invention. There are circumstances in which a highly-accurate, high performance reference, such as a clock generator (**100**, **200** or **300**) of the invention, is unnecessary, such as in a low power, standby mode. In these circumstances, in accordance with the invention, either no clock output is provided, or a low power, reduced performance clock **1105** output is provided. For example, at comparatively low frequencies, a low performance ring oscillator may provide suitable performance with low power consumption. As illustrated in **FIG. 17**, for these conditions, the output of the low power oscillator **1105** may be selected (through multiplexer **1100**), and provided as a clock output to other circuitry. At higher frequencies, however, such low performance oscillators consume considerably more power, typically significantly more than the oscillator of the present invention. There is typically a “break-even” point as a function of frequency, after which the clock generator (**100**, **200** or **300**) provides both higher performance and lower power consumption, and may be selected (through multiplexer **1100**), and provided as a clock output to other circuitry. As a consequence, the clock generator (**100**, **200** or **300**) may also be utilized to provide a low power mode.

[**0170**] In addition, using mode selector **1110**, other modes may be selected, such as a no power mode, rather than merely a low-frequency or sleep mode, as the clock generator (**100**, **200** or **300**) may be restarted comparatively rapidly, or a pulsed mode, in which the clock generator (**100**,

200 or **300**) is repeatedly stopped and restarted, periodically or non-periodically, in bursts or intervals. Various reference modes are discussed below.

[**0171**] In sharp contrast to the prior art, this pulsed clocking using the clock generator and/or timing/frequency reference (**100**, **200** or **300**) of the present invention provides power savings or conservation. While more power may be consumed during a given burst, as the clock has a comparatively high frequency, more instructions are processed in that interval, followed by no or limited power dissipation during the non-pulse or off interval, resulting in higher MIPS/mW compared to a continuously running clock. In contrast, due to the comparatively long start-up time and locking of prior art clocks, such pulsed clocking results in more power consumption and less efficiency in the prior art.

[**0172**] **FIG. 18** is a block diagram illustrating an exemplary synchronization module **1200** for a second oscillator in accordance with the teachings of the present invention. As mentioned above, the clock generator and/or timing/frequency reference (**100**, **200** or **300**) may provide a reference mode to synchronize other oscillators or clocks, which may or may not be low power, such as second oscillator **1210** (e.g., ring, relaxation, or phase shift oscillators). An output signal from the clock generator and/or timing/frequency reference (**100**, **200** or **300**) is further frequency divided as needed to form a plurality of available reference frequencies, with a reference frequency selected from this plurality of frequencies. This may be accomplished using the modules discussed above, such as by using the existing frequency dividers (**220**, **330**, **1000**, for example), and then providing the reference signal from the frequency selector **1050** (or **205** or **335**). For example, referring to **FIG. 3**, mode selector **345** may select a reference mode and provide the output reference signal from frequency selector **335** to a second oscillator (with synchronization module) **375**. A synchronization module, such as PLL or DLL **1205**, is then utilized to synchronize the output signal from the second oscillator **1210** to the reference signal provided by clock generator and/or timing/frequency reference (**100**, **200** or **300**). In addition to a mode of continuous synchronization, a pulsed-synchronization may also be provided, in which the clock generator and/or timing/frequency reference (**100**, **200** or **300**) provides a pulsed output, and synchronization occurs during the interval of these pulses, as a synchronization interval.

[**0173**] **FIG. 19** is a flow diagram illustrating an exemplary method in accordance with the teachings of the present invention, and provides a useful summary. The method begins with start step **1220**, such as through clock generator and/or timing/frequency reference (**100**, **200** or **300**) start-up. It should be noted that while illustrated in **FIG. 19** as consecutive steps, these steps may occur in any order, and generally may occur concurrently as the clock generator and/or timing/frequency reference (**100**, **200** or **300**) operates. Referring to **FIG. 19**, a resonant signal having a resonant frequency is generated, step **1225**, such as through LC tank **405** or resonator **310**. The resonant frequency is adjusted in response to temperature, step **1230**, such as through a temperature compensator **315**, which adjusts current and frequency. The resonant frequency is adjusted in response to fabrication process variation, step **1235**, such as through process variation compensator **320**. As indicated above, step **1235** may be performed as a first calibration

step, followed by the temperature adjustment of step 1230. The resonant signal having the resonant frequency is divided into a plurality of second signals having a corresponding plurality of frequencies, in which the plurality of frequencies are substantially equal to or lower than the resonant frequency, step 1240, such as through frequency divider 330 or 1000). An output signal is selected from the plurality of second signals, step 1245, such as through frequency selector 335 or 1650, for example. Depending upon the selected embodiment or mode, the selected output signal may be provided directly, for example, as a reference signal.

[0174] In other embodiments, such as when the output signal is a differential rather than single-ended signal, and when the resonant signal is a substantially sinusoidal signal, the method continues with converting the differential, substantially sinusoidal signal to a single-ended, substantially square wave signal having a substantially equal high and low duty cycle, as needed, step 1250, such as to generate a clock output signal using modules 330 or 1000, for example. An operating mode is also selected from a plurality of operating modes, step 1255, where the plurality of operating modes can be selected from a group comprising a clock mode, a timing and frequency reference mode, a power conservation mode, and a pulsed mode, for example, such as using mode selector 225 or 345. When a reference mode is selected in step 1255, in step 1260, the method proceeds to step 1265, to synchronize a third signal (e.g., from a second oscillator) in response to the output signal, such as illustrated in FIG. 18. Following steps 1260 or 1265, the method may end or repeat (continue) (such as with the clock generator and/or timing/frequency reference (100, 200 or 300) running continuously), return step 1270.

[0175] Also in summary, the present invention provides an apparatus comprising a resonator adapted to provide a first signal having a resonant frequency; an amplifier coupled to the resonator; and a frequency controller (coupled to the resonator) which is adapted to select a resonant frequency having a first frequency of a plurality of frequencies. The apparatus also includes a frequency divider (coupled to the resonator) which is adapted to divide the first signal having the first frequency into a plurality of second signals having a corresponding plurality of frequencies, the plurality of frequencies substantially equal to or lower than the first frequency, such as by division by a rational number.

[0176] The first signal may be a differential signal or a single-ended signal. When the first signal is a differential signal, the frequency divider is further adapted to convert the differential signal to a single-ended signal. Similarly, when the first signal is a substantially sinusoidal signal, the frequency divider is further adapted to convert the substantially sinusoidal signal to a substantially square wave signal.

[0177] In various embodiments, the frequency divider may comprise a plurality of flip-flops or counters coupled successively in series, wherein an output of a selected flip-flop or counter is a frequency of a previous flip-flop or counter divided by two, or more generally, a plurality of dividers coupled successively in series, wherein an output of a successive divider is a lower frequency than the output of a previous divider. The plurality of dividers may be differential, single-ended, or differential and single-ended, such as differential followed by a final single-ended stage. The frequency divider may also include a square-wave generator

adapted to convert the first signal into a substantially square-wave signal having a substantially equal high and low duty cycle.

[0178] The present invention may also include a frequency selector coupled to the frequency divider, and adapted to provide an output signal from the plurality of second signals. The frequency selector may further comprise a multiplexer and a glitch-suppressor.

[0179] The present invention may also include a mode selector coupled to the frequency selector, wherein the mode selector is adapted to provide a plurality of operating modes, which may be selected from a group comprising a clock mode, a timing and frequency reference mode, a power conservation mode, and a pulsed mode.

[0180] For a reference mode, the invention may also include a synchronization circuit coupled to the mode selector; and a controlled oscillator coupled to the synchronization circuit and adapted to provide a third signal; wherein in the timing and reference mode, the mode selector is further adapted to couple the output signal to the synchronization circuit to control timing and frequency of the third signal. Such a synchronization circuit may be a delay-locked loop, a phase-locked loop, or an injection locking circuit.

[0181] In selected embodiments, the amplifier may be a negative transconductance amplifier. The frequency controller may be further adapted to modify a current through the negative transconductance amplifier in response to temperature, and may comprise a current source responsive to temperature. Such a current source may have one or more configurations selected from a plurality of configurations, such as the plurality of configurations comprising CTAT, PTAT, and PTAT² configurations. In addition, the frequency controller may be further adapted to modify a current through the negative transconductance amplifier to select the resonant frequency, modify a transconductance of the negative transconductance amplifier to select the resonant frequency, or modify a current through the negative transconductance amplifier in response to a voltage. The frequency controller may also include a voltage isolator coupled to the resonator and adapted to substantially isolate the resonator from a voltage variation, and may comprise a current mirror, which may further have a cascode configuration. The frequency controller may be further adapted to modify a capacitance or an inductance of the resonator in response to fabrication process variation, temperature variation, or voltage variation.

[0182] The frequency controller may have various embodiments for these various functions, and may further comprise: a coefficient register adapted to store a first plurality of coefficients; and a first array having a plurality of switchable capacitive modules coupled to the coefficient register and to the resonator, each switchable capacitive module having a fixed capacitance and a variable capacitance, each switchable capacitive module responsive to a corresponding coefficient of the first plurality of coefficients to switch between the fixed capacitance and the variable capacitance and to switch each variable capacitance to a control voltage. The plurality of switchable capacitive modules may be binary-weighted, or have another weighting scheme. The frequency controller may also include a second array having a plurality of switchable resistive modules coupled to the coefficient register and further having a

capacitive module, the capacitive module and the plurality of switchable resistive modules further coupled to a node to provide the control voltage, each switchable resistive module responsive to a corresponding coefficient of a second plurality of coefficients stored in the coefficient register to switch the switchable resistive module to the control voltage node; and a temperature-dependent current source coupled through a current mirror to the second array.

[0183] The frequency controller may also include a process variation compensator coupled to the resonator and adapted to modify the resonant frequency in response to fabrication process variation. In an exemplary embodiment, the process variation compensator may comprise: a coefficient register adapted to store a plurality of coefficients; and an array having a plurality of switchable capacitive modules coupled to the coefficient register and to the resonator, each switchable capacitive module having a first fixed capacitance and a second fixed capacitance, each switchable capacitive module responsive to a corresponding coefficient of the plurality of coefficients to switch between the first fixed capacitance and the second fixed capacitance. The plurality of switchable capacitive modules may be binary-weighted, or have another weighting scheme.

[0184] In another exemplary embodiment the process variation compensator may comprise: a coefficient register adapted to store a plurality of coefficients; and an array having a plurality of switchable variable capacitive modules coupled to the coefficient register and to the resonator, each switchable variable capacitive module responsive to a corresponding coefficient of the plurality of coefficients to switch between a first voltage and a second voltage. The plurality of switchable variable capacitive modules also may be binary-weighted, or have another weighting scheme.

[0185] The present invention may also include a frequency calibration module coupled to the frequency controller and adapted to modify the resonant frequency in response to a reference signal. For example, the frequency calibration module may include a frequency divider coupled to the frequency controller, the frequency divider adapted to convert an output signal derived from the first signal having the first frequency to a lower frequency to provide a divided signal; a frequency detector coupled to the frequency divider, the frequency detector adapted to compare the reference signal to the divided signal and provide one or more up signals or down signals; and a pulse counter coupled to the frequency detector, the pulse counter adapted to determine a difference between the one or more up signals or down signals as an indicator of a difference between the output signal and the reference signal.

[0186] The resonator used with the invention may comprise an inductor (L) and a capacitor (C) coupled to form an LC-tank, having a selected configuration of a plurality of LC-tank configurations, such as series, parallel and so on, and may include other components. In other embodiments, the resonator may be selected from a group comprising: a ceramic resonator, a mechanical resonator, a microelectromechanical resonator, and a film bulk acoustic resonator, or any other resonator which is electrically equivalent to an inductor (L) coupled to a capacitor (C).

[0187] The apparatus of the invention may be utilized as a timing and frequency reference, or as a clock generator. In addition, the invention may also include a second oscillator

(such as a ring, relaxation, or phase shift oscillator) providing a second oscillator output signal; and a mode selector coupled to the frequency controller and to the second oscillator, the mode selector adapted to switch to the second oscillator output signal to provide a power conservation mode. Additional operating modes may be provided by a mode selector coupled to the frequency controller, which may be adapted to periodically start and stop the resonator to provide a pulsed output signal, or adapted to selectively start and stop the resonator to provide a power conservation mode.

[0188] In another selected embodiment, the apparatus of the invention, comprises: a resonator adapted to provide a first signal having a resonant frequency; an amplifier coupled to the resonator; a temperature compensator coupled to the amplifier and to the resonator, the temperature compensator adapted to modify the resonant frequency in response to temperature; a process variation compensator coupled to the resonator, the process variation compensator adapted to modify the resonant frequency in response to fabrication process variation; a frequency divider coupled to the resonator, the frequency divider adapted to divide the first signal having the resonant frequency into a plurality of second signals having a corresponding plurality of frequencies, the plurality of frequencies substantially equal to or lower than the resonant frequency; and a frequency selector coupled to the frequency divider, the frequency selector adapted to provide an output signal from the plurality of second signals.

[0189] In another selected embodiment, the apparatus of the invention generates a clock signal, and comprises: an LC resonator adapted to provide a differential, substantially sinusoidal first signal having a resonant frequency; a negative transconductance amplifier coupled to the LC resonator; a temperature compensator coupled to the negative transconductance amplifier and to the LC resonator, the temperature compensator adapted to modify a current in the negative transconductance amplifier in response to temperature and further to modify a capacitance of the LC resonator in response to temperature; a process variation compensator coupled to the LC resonator, the process variation compensator adapted to modify the capacitance of the LC resonator in response to fabrication process variation; a frequency divider coupled to the resonator, the frequency divider adapted to convert and divide the first signal having the resonant frequency into a plurality of single-ended, substantially square-wave second signals having a corresponding plurality of frequencies, the plurality of frequencies substantially equal to or lower than the resonant frequency, and each second signal having a substantially equal high and low duty cycle; and a frequency selector coupled to the frequency divider, the frequency selector adapted to provide an output signal from the plurality of second signals.

[0190] From the foregoing, it will be observed that numerous variations and modifications may be effected without departing from the spirit and scope of the novel concept of the invention. It is to be understood that no limitation with respect to the specific methods and apparatus illustrated herein is intended or should be inferred. It is, of course, intended to cover by the appended claims all such modifications as fall within the scope of the claims.

It is claimed:

1. An apparatus for frequency control of an integrated, free-running harmonic oscillator, the apparatus comprising:

a plurality of resistive modules adapted to generate a plurality of control voltages;

a plurality of controlled reactance modules coupled to the harmonic oscillator; and

a plurality of switches coupled to the plurality of resistive modules and to the plurality of controlled reactance modules, the plurality of switches responsive to a control signal to couple a first control voltage of the plurality of control voltages to a first controlled reactance module of the plurality of controlled reactance modules to modify a resonant frequency of the harmonic oscillator.

2. The apparatus of claim 1, wherein at least one control voltage of the plurality of control voltages is responsive to a parameter of a plurality of parameters.

3. The apparatus of claim 2, wherein the plurality of parameters are variable and comprise at least one of the following parameters: temperature, fabrication process, voltage, age, and frequency.

4. The apparatus of claim 2, further comprising:

a current source coupled to the plurality of resistive modules, the current source adapted to provide a parameter-dependent current to at least one resistive module of the plurality of resistive modules to generate at least one control voltage, of the plurality of control voltages, which is parameter-dependent.

5. The apparatus of claim 2, further comprising:

a current source coupled to the plurality of resistive modules, the current source adapted to provide a substantially parameter-independent current to at least one resistive module of the plurality of resistive modules to generate at least one control voltage, of the plurality of control voltages, which is substantially parameter-independent.

6. The apparatus of claim 1, wherein at least one control voltage of the plurality of control voltages is temperature-dependent and wherein at least one control voltage of the plurality of control voltages is substantially temperature-independent.

7. The apparatus of claim 1, further comprising:

a coefficient register coupled to the plurality of switches and adapted to store a first plurality of coefficients, wherein the control signal is provided by at least one coefficient of the first plurality of coefficients.

8. The apparatus of claim 7, wherein the plurality of controlled reactance modules further comprise a plurality of differently-weighted fixed capacitances and variable capacitances, and wherein the plurality of switches are responsive to the first plurality of coefficients to couple a fixed capacitance to the harmonic oscillator and to couple a first control voltage of the plurality of control voltages to a variable capacitance coupled to the harmonic oscillator.

9. The apparatus of claim 8, wherein the plurality of resistive modules further comprise a plurality of switchable resistive modules coupled to the coefficient register and a capacitive module, the capacitive module and the plurality of switchable resistive modules further coupled to a node to provide the first control voltage, each switchable resistive

module responsive to a corresponding coefficient of a second plurality of coefficients stored in the coefficient register to switch the switchable resistive module to the control voltage node.

10. The apparatus of claim 9, further comprising:

a current source responsive to temperature, and wherein the current source is coupled through a current mirror to the plurality of switchable resistive modules to generate the first control voltage across at least one switchable resistive module of the plurality of switchable resistive modules.

11. The apparatus of claim 10, wherein the current source has at least one complementary to absolute temperature (CTAT) configuration, proportional to absolute temperature (PTAT) configuration, or proportional to absolute temperature squared (PTAT²) configuration.

12. The apparatus of claim 10, wherein each switchable resistive module of the plurality of switchable resistive modules has a different temperature response for a selected current.

13. The apparatus of claim 10, further comprising:

an analog-to-digital converter coupled to the plurality of switchable resistive modules to provide a digital output signal in response to the first control voltage; and

a control logic block to convert the digital output signal to the first plurality of coefficients or to the control signal.

14. The apparatus of claim 7, wherein the plurality of controlled reactance modules further comprise:

a plurality of switchable capacitive modules coupled to the coefficient register and coupleable to the harmonic oscillator, each switchable capacitive module having a variable capacitance, each switchable capacitive module responsive to a corresponding coefficient of the first plurality of coefficients to switch the variable capacitance to a selected control voltage of the plurality of control voltages.

15. The apparatus of claim 14, further comprising:

a current source responsive to a parameter of a plurality of variable parameters, wherein the current source is coupled through a current mirror to the plurality of resistive modules;

and wherein each resistive module of the plurality of resistive modules has a different response to the parameter and is adapted to provide a corresponding control voltage, of the plurality of control voltages, in response to a current from the current source.

16. The apparatus of claim 15, wherein at least one control voltage of the plurality of control voltages is parameter-dependent and at least one control voltage of the plurality of control voltages is substantially parameter-independent.

17. The apparatus of claim 7, wherein the plurality of controlled reactance modules further comprise:

a plurality of differently-weighted switchable capacitive modules coupled to the coefficient register and to the harmonic oscillator, each switchable capacitive module having a first fixed capacitance and a second fixed capacitance, each switchable capacitive module responsive to a corresponding coefficient of the plurality of coefficients to switch between the first fixed capacitance and the second fixed capacitance.

18. The apparatus of claim 7, wherein the plurality of controlled reactance modules further comprise:

at least one switchable variable capacitive module coupled to the coefficient register and to the harmonic oscillator, the at least one switchable variable capacitive module responsive to a corresponding coefficient of the plurality of coefficients to switch between a first voltage and a second voltage of a plurality of control voltages.

19. The apparatus of claim 7, wherein the plurality of controlled reactance modules further comprise:

a plurality of switchable variable capacitive modules coupled to the coefficient register and to the harmonic oscillator, each switchable variable capacitive module responsive to a corresponding coefficient of the plurality of coefficients to switch to a selected control voltage of a plurality of control voltages, the plurality of control voltages comprising a plurality of different magnitude voltages, and wherein the selected control voltage is substantially constant over temperature variations.

20. The apparatus of claim 1, wherein the plurality of controlled reactance modules further comprises an inductance coupleable to the harmonic oscillator.

21. The apparatus of claim 1, further comprising:

a plurality of switchable resistors responsive to a control signal to switch a corresponding resistance to the harmonic oscillator to modify the resonant frequency.

22. The apparatus of claim 1, further comprising:

a voltage divider coupled to the plurality of controlled reactance modules and adapted to provide a selected control voltage responsive to voltage variations.

23. The apparatus of claim 1, further comprising:

an age variation compensator coupled to the harmonic oscillator and adapted to compare a current value of a selected parameter of the plurality of parameters to an initial value of the selected parameter and to modify the resonant frequency in response to a difference between the current value and the initial value of the selected parameter.

24. An apparatus for frequency control of an integrated, free-running harmonic oscillator, the apparatus comprising:

a resonator adapted to provide a first signal having a resonant frequency;

a sensor adapted to provide a second signal in response to at least one parameter of a plurality of parameters; and

a frequency controller coupled to the sensor and to the resonator, the frequency controller adapted to modify an impedance element coupled to the resonator in response to the second signal to modify the resonant frequency.

25. The apparatus of claim 24, wherein the plurality of parameters are variable and comprise at least one of the following parameters: temperature, fabrication process, voltage, age, and frequency.

26. The apparatus of claim 24, wherein the frequency controller is further adapted to modify a total capacitance of the resonator in response to the second signal.

27. The apparatus of claim 26, wherein the frequency controller further comprises:

a plurality of controlled capacitance modules comprising a corresponding plurality of fixed capacitances and variable capacitances, and further comprising a plurality of switches coupled to the plurality of fixed capacitances and variable capacitances.

28. The apparatus of claim 27, wherein the frequency controller is further adapted to couple to the resonator or decouple from the resonator a fixed or variable capacitance of the plurality of fixed capacitances and variable capacitances.

29. The apparatus of claim 27, wherein the frequency controller further comprises:

a plurality of resistive modules adapted to generate a plurality of control voltages, the plurality of control voltages comprising a corresponding plurality of different magnitude voltages, and wherein the frequency controller is further adapted to switch a first control voltage of the plurality of control voltages to a variable capacitance of the plurality of fixed capacitances and variable capacitances to modify the total capacitance of the resonator.

30. The apparatus of claim 29, wherein at least one control voltage of the plurality of control voltages is temperature-dependent and wherein at least one control voltage of the plurality of control voltages is substantially temperature-independent.

31. The apparatus of claim 29, wherein the second signal is at least one control voltage of the plurality of control voltages.

32. The apparatus of claim 29, wherein the frequency controller further comprises a coefficient register adapted to store a first plurality of coefficients; and wherein the plurality of controlled capacitance modules further comprise a first array comprising a plurality of binary-weighted, switchable capacitive modules coupled to the coefficient register and to the resonator, each switchable capacitive module having a fixed capacitance and a variable capacitance, each switchable capacitive module responsive to a corresponding coefficient of the first plurality of coefficients to switch between the fixed capacitance and the variable capacitance and to switch each variable capacitance to a selected control voltage of the plurality of control voltages.

33. The apparatus of claim 32, wherein the plurality of resistive modules further comprise a second array having a plurality of switchable resistive modules coupled to the coefficient register and further having a capacitive module, the capacitive module and the plurality of switchable resistive modules further coupled to a node to provide the selected control voltage, each switchable resistive module responsive to a corresponding coefficient of a second plurality of coefficients stored in the coefficient register to switch the switchable resistive module to the control voltage node.

34. The apparatus of claim 33, wherein the sensor further comprises a current source responsive to temperature, and wherein the current source is coupled through a current mirror to the second array to generate the selected control voltage across at least one switchable resistive module of the plurality of switchable resistive modules.

35. The apparatus of claim 34, wherein the current source has at least one complementary to absolute temperature (CTAT) configuration, proportional to absolute temperature (PTAT) configuration, or proportional to absolute temperature squared (PTAT²) configuration.

36. The apparatus of claim 34, wherein each switchable resistive module of the plurality of switchable resistive modules has a different temperature response for a selected current.

37. The apparatus of claim 32, wherein the sensor is a temperature sensor and varies the second signal in response to temperature variation.

38. The apparatus of claim 37, further comprising an analog-to-digital converter coupled to the temperature sensor to provide a digital output signal in response to the second signal.

39. The apparatus of claim 38, further comprising a control logic block to convert the digital output signal to the first plurality of coefficients.

40. The apparatus of claim 24, wherein the frequency controller further comprises:

- a coefficient register adapted to store at least one coefficient; and

- at least one switchable capacitive modules coupled to the coefficient register and coupleable to the resonator, the at least one switchable capacitive module having a variable capacitance and responsive to the coefficient to switch the variable capacitance to a selected control voltage of a plurality of control voltages.

41. The apparatus of claim 40, wherein the sensor comprises a current source responsive to temperature, and wherein the frequency controller further comprises:

- a plurality of resistive modules coupled through a current mirror to the current source, the plurality of resistive modules adapted to provide the plurality of control voltages, and wherein each resistive module of the plurality of resistive modules has a different response to temperature and is adapted to provide a corresponding control voltage, of the plurality of control voltages, in response to a current from the current source.

42. The apparatus of claim 24, wherein the frequency controller is further adapted to modify an inductance of the resonator in response to the second signal.

43. The apparatus of claim 24, wherein the frequency controller is further adapted to modify a resistance of the resonator in response to the second signal.

44. The apparatus of claim 24, wherein the frequency controller further comprises:

- a process variation compensator coupled to the resonator and adapted to modify the resonant frequency in response to a fabrication process parameter of the plurality of parameters.

45. The apparatus of claim 44, wherein the process variation compensator further comprises:

- a coefficient register adapted to store a plurality of coefficients; and

- an array comprising a plurality of switchable capacitive modules coupled to the coefficient register and to the resonator, each switchable capacitive module having a first fixed capacitance and a second fixed capacitance, each switchable capacitive module responsive to a corresponding coefficient of the plurality of coefficients to switch between the first fixed capacitance and the second fixed capacitance.

46. The apparatus of claim 44, wherein the process variation compensator further comprises:

- a coefficient register adapted to store a plurality of coefficients; and

- an array comprising a plurality of switchable variable capacitive modules coupled to the coefficient register and to the resonator, each switchable variable capacitive module responsive to a corresponding coefficient of the plurality of coefficients to switch between a first voltage and a second voltage.

47. The apparatus of claim 44, wherein the process variation compensator further comprises:

- a coefficient register adapted to store a plurality of coefficients; and

- an array comprising a plurality of switchable variable capacitive modules coupled to the coefficient register and to the resonator, each switchable variable capacitive module responsive to a corresponding coefficient of the plurality of coefficients to switch to a selected control voltage of a plurality of control voltages, the plurality of control voltages comprising a plurality of different magnitude voltages, and wherein the selected control voltage is substantially constant over temperature variations.

48. The apparatus of claim 47, wherein the frequency controller further comprises:

- a voltage variation compensator coupled to the resonator and adapted to modify the resonant frequency in response to a voltage parameter of the plurality of parameters.

49. The apparatus of claim 47, wherein the frequency controller further comprises:

- an age variation compensator coupled to the resonator and adapted to compare a current value of a selected parameter of the plurality of parameters to an initial value of the selected parameter and to modify the resonant frequency in response to a difference between the current value and the initial value of the selected parameter.

50. An apparatus for frequency control of a resonator, the resonator adapted to provide a first signal having a resonant frequency, the apparatus comprising:

- a coefficient register adapted to store a first plurality of coefficients; and

- a first array having a plurality of switchable reactance modules coupled to the coefficient register and to the resonator, each switchable reactance module responsive to a corresponding coefficient of the first plurality of coefficients to switch a corresponding reactance to the resonator to modify the resonant frequency.

51. The apparatus of claim 50, wherein the plurality of switchable reactance modules are binary-weighted.

52. The apparatus of claim 50, wherein the corresponding reactance is a fixed or variable inductance.

53. The apparatus of claim 50, wherein the corresponding reactance is a fixed or variable capacitance.

54. The apparatus of claim 50, wherein the corresponding reactance is switched between the resonator and a control voltage, a supply voltage or a ground potential.

55. The apparatus of claim 54, wherein the control voltage is determined by a current source responsive to temperature.

56. The apparatus of claim 50, wherein the corresponding reactance is variable and is switched between the resonator and a selected control voltage of a plurality of control voltages.

57. The apparatus of claim 50, wherein the first plurality of coefficients are calibrated.

58. The apparatus of claim 50, wherein the first plurality of coefficients are determined by a sensor responsive to at least one parameter of a plurality of variable parameters.

59. The apparatus of claim 58, wherein the plurality of variable parameters comprise temperature, fabrication process, voltage, age, and frequency.

60. The apparatus of claim 50, wherein the plurality of switchable reactance modules further comprise:

a plurality of binary-weighted switchable capacitive modules, each switchable capacitive module having a fixed capacitance and a variable capacitance, each switchable capacitive module responsive to a corresponding coefficient of the first plurality of coefficients to switch between the fixed capacitance and the variable capacitance and to switch each variable capacitance to a control voltage.

61. The apparatus of claim 60, further comprising:

a current source responsive to temperature; and

a second array having a plurality of switchable resistive modules coupled to the coefficient register and selectively coupleable to the current source, the second array further having a capacitive module, the capacitive module and the plurality of switchable resistive modules further coupled to a node to provide the control voltage, each switchable resistive module responsive to a corresponding coefficient of a second plurality of coefficients stored in the coefficient register to switch the switchable resistive module to the control voltage node, and wherein each switchable resistive module of the plurality of switchable resistive modules has a different temperature response for a selected current from the current source.

62. The apparatus of claim 50, wherein the plurality of switchable reactance modules further comprise:

a plurality of switchable capacitive modules, each switchable capacitive module having a variable capacitance, each switchable capacitive module responsive to a corresponding coefficient of the first plurality of coefficients to switch the variable capacitance to a selected control voltage of a plurality of control voltages.

63. The apparatus of claim 62, further comprising:

a current source responsive to temperature; and

a second array having a plurality of resistive modules coupled through a current mirror to the current source, the plurality of resistive modules adapted to provide the plurality of control voltages, and wherein each resistive module of the plurality of resistive modules has a different response to temperature and is adapted to provide a corresponding control voltage, of the plurality of control voltages, in response to a current from the current source.

64. The apparatus of claim 63, wherein at least one control voltage of the plurality of control voltages is responsive to

temperature and at least one control voltage of the plurality of control voltages is substantially non-responsive to temperature.

65. The apparatus of claim 50, wherein the plurality of switchable reactance modules further comprise:

a plurality of binary-weighted switchable capacitive modules coupled to the coefficient register and to the resonator, each switchable capacitive module having a first fixed capacitance and a second fixed capacitance, each switchable capacitive module responsive to a corresponding coefficient of the plurality of coefficients to switch between the first fixed capacitance and the second fixed capacitance.

66. The apparatus of claim 50, wherein the plurality of switchable reactance modules further comprise:

a plurality of switchable variable capacitive modules coupled to the coefficient register and to the resonator, each switchable variable capacitive module responsive to a corresponding coefficient of the plurality of coefficients to switch between a first voltage and a second voltage.

67. An apparatus for frequency control in response to temperature variation, the apparatus comprising:

a resonator, the resonator adapted to provide a first signal having a resonant frequency; and

a temperature compensator coupled to the resonator, the temperature compensator adapted to modify the resonant frequency in response to temperature variation.

68. The apparatus of claim 67, further comprising:

a negative transconductance amplifier coupled to the resonator and to the temperature compensator;

and wherein the temperature compensator further comprises a current source responsive to temperature variation and is further adapted to modify a current through the negative transconductance amplifier in response to temperature variation.

69. The apparatus of claim 67, wherein the temperature compensator further comprises:

a current source adapted to provide a current responsive to temperature variation;

a coefficient register adapted to store a first plurality of coefficients;

a plurality of resistive modules coupled to the resonator and the current source, at least one resistive module of the plurality of resistive modules adapted to provide a control voltage; and

a plurality of switchable reactance modules coupled to the resonator and to the current source and selectively coupleable to at least one resistive module of the plurality of resistive modules.

70. The apparatus of claim 69, wherein the plurality of switchable reactance modules further comprise:

a plurality of binary-weighted switchable capacitive modules, each switchable capacitive module having a fixed capacitance and a variable capacitance, each switchable capacitive module responsive to a corresponding coefficient of the first plurality of coefficients to switch

between the fixed capacitance and the variable capacitance and to switch each variable capacitance to the control voltage.

71. The apparatus of claim 69, wherein each resistive module of the plurality of resistive modules is adapted to provide a corresponding control voltage to form a plurality of control voltages, and wherein the plurality of switchable reactance modules further comprise:

a plurality of switchable capacitive modules, each switchable capacitive module having a variable capacitance, each switchable capacitive module responsive to a corresponding coefficient of the first plurality of coefficients to switch the variable capacitance to a selected control voltage of the plurality of control voltages.

72. A frequency controller for frequency control of a resonator, the frequency controller comprising:

a coefficient register adapted to store a first plurality of coefficients and a second plurality of coefficients;

a current source adapted to provide a current corresponding to a temperature;

a first array having a plurality of switchable resistive modules coupled to the coefficient register -and further having a capacitive module, the first array further coupled through a current mirror to the current source to create at least one control voltage across at least one switchable resistive module of the plurality of switchable resistive modules, each switchable resistive module responsive to a corresponding coefficient of the second plurality of coefficients to switch the switchable resistive module to provide the control voltage to a control voltage node; and

a second array having a plurality of switchable capacitive modules coupled to the coefficient register and to the resonator, each switchable capacitive module having a fixed capacitance and a variable capacitance, each switchable capacitive module responsive to a corresponding coefficient of the first plurality of coefficients to switch between the fixed capacitance and the variable capacitance and to switch each variable capacitance to the control voltage node.

73. A frequency controller for frequency control of a resonator, the frequency controller comprising:

a coefficient register adapted to store a first plurality of coefficients;

a current source;

a first array having a plurality of switchable resistive modules coupled to the coefficient register and coupled through a current mirror to the current source to create a plurality of control voltages; and

a second array having a plurality of switchable and variable capacitive modules coupled to the coefficient register and to the resonator, the second array further selectively couplable to the first array, each switchable capacitive module responsive to a corresponding coefficient of the first plurality of coefficients to switch the variable capacitance to a selected control voltage of the plurality of control voltages.

* * * * *