

12 **EUROPEAN PATENT APPLICATION**

21 Application number: **82850063.7**

51 Int. Cl.³: **B 65 D 81/34**

22 Date of filing: **25.03.82**

30 Priority: **10.04.81 SE 8102315**

43 Date of publication of application:
20.10.82 Bulletin 82/42

84 Designated Contracting States:
AT BE CH DE FR GB IT LI LU NL

71 Applicant: **AB Akerlund & Rausing**
Fack 1702
S-221 01 Lund(SE)

72 Inventor: **Björkengren, Carl-Axel**
Trastvägen 104
S-230 47 Akarp(SE)

74 Representative: **Graudums, Valdis et al,**
Backers Patentbyrå AB Drottninggatan 15
S-411 14 Göteborg(SE)

54 **Packaging material.**

57 The invention provides a packaging material for food-stuff products intended to be inserted directly into a processing oven, as well a conventional heating oven as a microwave oven. The packaging material is such that at least a region of one side thereof is provided with a coating comprising heat radiation reflecting material allowing transmission of microwave energy.

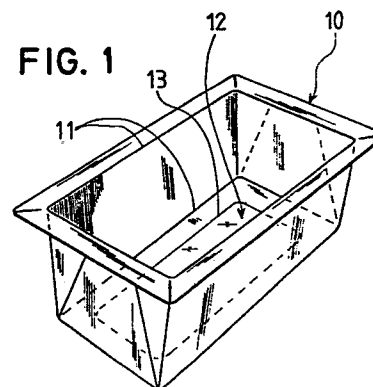

Packaging material.Field of the invention

The present invention relates to a packaging material and more precisely to a material suitable for food product containing packages intended to be inserted directly into a processing oven, as well an ordinary heating oven as a microwave oven.

Background of the invention

The fact that the packaging material according to the invention is useful in as well heat oven applications as microwave oven applications implies that the invention provides a solution to what might look as a contradictory, incompatible problem of providing as well microwave transmission as heat radiation reflecting properties.

Previously, one has had to adhere to either the one or the other possibility, i.e. if microwave technique for heating of the product that has been packed has been a stipulation, the packaging material basically has consisted of a cardboard substrate coated by polyester or a corresponding heat resistant material. If, on the other hand, the use of an ordinary heating oven has been a stipulation, this has required a packaging material lined with a heat radiation reflecting, polyester coated aluminium foil or corresponding liner.

The latter type of material is completely useless in microwave ovens, since the Al-foil fully reflects the microwave radiation back to the klystron without effecting heating of the contents of the package, but certainly destruction of the klystron.

The former type of material is on the other hand useful in microwave applications, but not in heating ovens. This depends on the fact that the heat radiation from the oven as well as radiation from the food product that is packed creates, generally more or less local, hot spots of such a high temperature that the cardboard material below the polyester layer dry-distillates, i.e. chars. This makes the contents of the package more or less distasteful.

However, there exists a clearly defined need, not at least depending on the increasing number of microwave ovens, for the consumer to have a free choice of placing the "ready packed" food product she/he has bought either in a heat
5 oven or microwave oven without risking that anything unexpected occurs.

Objects of the invention

The main object of the invention is to satisfy the need just mentioned.

10 Another object of the invention is to solve the dual-purpose main problem, microwave transmission/heat radiation reflection, while still providing a packaging material capable of being processed by ordinary converting techniques.

A further object is to maintain the possibility of
15 using printing facilities of the type generally found within the packaging industry.

A still further object is to provide cardboard type packaging materials which will withstand temperature exposure up to about 250^o C during time intervals of 20 to 30
20 minutes.

Yet another object is to provide measures for arranging heat radiation reflecting regions in selected areas only of the packaging material, while maintaining sufficient heat resistance characteristics.

25 An additional object is to provide a packaging material which will also withstand mechanical wear and prevent smearing of the printing ink.

Summary of the invention

In the broadest sense thereof, the invention provides
30 a packaging material based on cardboard or a similar material which is formable into a suitable food-stuff package insertable with the food product contents thereof directly into a processing oven. According to the invention at least a region of one side of the packaging material is provided
35 with a coating comprising heat reflecting particles in a predetermined pattern, in for instance flake or particle shape.

In a preferred embodiment the said coating of heat reflecting particles is included within a layer of polyester, polymethylpenten or any other material, for instance polypropylene, having corresponding heat resistance characteristics.

Said heat resistant layer preferably has a surface weight of 15-30 g/m² and the contents of heat reflecting particles amounts to 0,01-1 % by weight of said surface weight.

10 The heat reflecting particles preferably consist of metal particles of aluminium or another food-stuff inert metal.

In an alternative embodiment the heat reflecting coating consists of a coating applied as a metallic printing ink, for instance by Offset-printing techniques, and forms a regular or irregular pattern or "grid" of dots, flakes, etc. having a total coverage of about 10-70 % of the surface.

By Offset-printing, the metallic printing ink may be applied in selected areas only. If, for instance, the package formed of the packaging material is a tray covered by a closure, the central regions of as well the closure as the bottom of the tray may be left unprinted. The contact between the food product and the unprinted regions will be sufficient for cooling the closure and the bottom to a non dry-distillating temperature, since the water contents of the food will limit the temperature to about 100° C in the contact areas.

Said printing ink advantageously is protected by a polyester layer or a correspondingly temperature and mechanical wear resistant layer, which preferably has a surface weight of up to about 15-30 g/m².

In combination with the protective plastic layer, for instance a polypropylene layer, a heat cureable lacquer, for instance of the acryle type might be used.

35 When a heat and wear resistant plastic layer, for instance a polyester layer with heat reflecting particles contained therein forms a heat radiation reflecting layer,

said layer preferably has randomly, but generally uniformly distributed heat reflecting particles.

According to the invention the said heat radiation reflecting coating which in one way or the other, by printing a metallic ink or extrusion coating a metal particle containing composition, comprises the said heat reflecting particles may exist on both sides of the packaging material.

Brief description of the drawings

Figure 1 is a schematic view of a preferred type of food product tray according to the teaching of the present invention, and

Figure 2 schematically shows the closure of the tray.

Specific description

In the embodiment according to Figures 1 and 2 the packaging material is used for the manufacture of trays intended for containing one or several portions of food-stuff. The tray 10 consists in the present case of the ordinary type of package cardboard material, having a gram-weight of 200-300 g. On both sides thereof the package blank has been provided with folding denotations and scores 11, respectively, for the in-line erection of the tray.

In the bottom area of the tray there is a region 12 defined by a closed line 13. On the outside thereof the tray is printed with a metallic ink, for instance an Aluminum-Bronze ink or a Gold-Bronze ink, in all areas except for the region 12.

The print has been applied by conventional Offset-printing of planar cardboard sheets, having a weight of 200-300 grams/m². In the Figure 1 version, the sheets from which individual package blanks are stamped out are coated on both sides thereof with a plastic layer, for instance a polypropylene layer in an amount of 15-30 g/m².

The tray closure 14 according to Figure 2 is of the same type of plastic coated cardboard material as the tray. There is a metallic printing ink on the side forming the outside of the closure 14, except for within the region 16 defined by line 15.

Within the printed areas, there is a total surface coverage of between 10-70 % of the entire printed surface. Such coverage may be demonstrated by for instance holding the cardboard material against a light source and observing the light transmission.

In order to improve the protection of the metallic ink and avoid smearing thereof when heating the material, the outside of the tray and closure may be covered by a lacquer, for instance of the acryle type.

The unprinted areas 12 and 16 provide "paper white" areas for displaying information on the contents of the package, etc. and generally may be tolerated also from a heating point of view, since tests have shown that the total heat reflecting capacity of a filled tray is sufficient for avoiding dry-distillation when heating in a conventional heating oven.

Such result presumably is due to the contribution of the contact between the food product and the central regions of the tray bottom and tray closure. The food product generally contains enough water which, when heating the tray and the food therein, results in a cooling effect on the bottom and the closure, since the temperature of the food will remain at about 100° C although the temperature within the oven, primarily determined by heat radiation from heating elements, is much higher.

In order to further improve the radiation heat resistance, also the areas 12 and 16 may be covered by a metallic ink.

Provided the total coverage falls within the interval prescribed, test have shown excellent results also in this case.

The metallization of the tray may be obtained also by extrusion coating techniques.

On the outside and/or inside of the tray, there may be a coating of a polyester, either a polyethyleneterephtalat or a polybutyleneterephtalat (PETP, PBTP) having aluminium particles dispersed therein. Said coating has of course been

obtained by coating a planar web, preferably by applying 15-30 g/m² of the plastic coating. The contents of aluminium particles, or other food inert metallic particles, may be selected within the range 0,01-1 %. Other extrusion coating
5 compositions may be prepared from polymethylpenten (TPX from ICI), HD-polypropylene or HD-polyethylene.

In the said plastic layer there exist aluminium particles in a so to say randomly, uniformly distributed configuration. In the direction of the microwave radiation, there
10 exist free passages. The availability of such free passages is determined by the weight proportion of heat reflecting metal particles. The existance of a heat reflecting coating on one side or both sides of the cardboard material is also a determinative factor. It has been found that the weight
15 proportion of heat reflecting particles should fall within the range of 0,01-1 % by weight of the total surface weight of the coating.

Although a few embodiments of the idea behind the invention have been described, it is realized that alternati-
20 ves, alterations, etc. are possible within the scope of the accompanying claims.

What we claim is:

1. Packaging material based on cardboard or similar material and formable into a package for insertion with food product contents directly into a processing oven, the improvement that at least a region of one side of the packaging material is provided with a coating comprising heat radiation reflecting material allowing transmission of microwave energy.
2. Packaging material as in claim 1, wherein the coating including the heat radiation reflecting material is applied as a metallic printing ink.
3. Packaging material as in claim 2, wherein the configuration of the printing ink forms a pattern of dots, flakes, etc. having a coverage of around 10-70 % of the total printed area.
4. Packaging material as in claim 3, wherein the printing ink is protected by a heat resistant layer, for instance polyester layer.
5. Packaging material as in claim 4, wherein the surface weight of the polyester layer amounts to approximately 15-30 g/m².
6. Packaging material as in claim 1, wherein the coating is included in an extrusion coated layer selected from the group of polyester, polymethylpenten, polypropylene and HD-polyethylene.
7. Packaging material as in claim 6, wherein the plastic layer has a surface weight of 15-30 g/m², and the heat radiation reflecting material is particular and amounts to 0,01-1 % of weight of said surface weight.
8. Packaging material as in claim 7, wherein the heat radiation reflecting particles consist of food inert metal particles, for instance aluminium particles.
9. Packaging material as in claim 6, wherein the coating having the heat radiation reflecting characteristics forms a layer of generally randomly, but substantially uniformly distributed heat radiation reflecting particles.

10. . Packaging material according to claim 1,
wherein said coating comprising heat reflecting material
exists on both sides of the packaging material.



FIG. 1

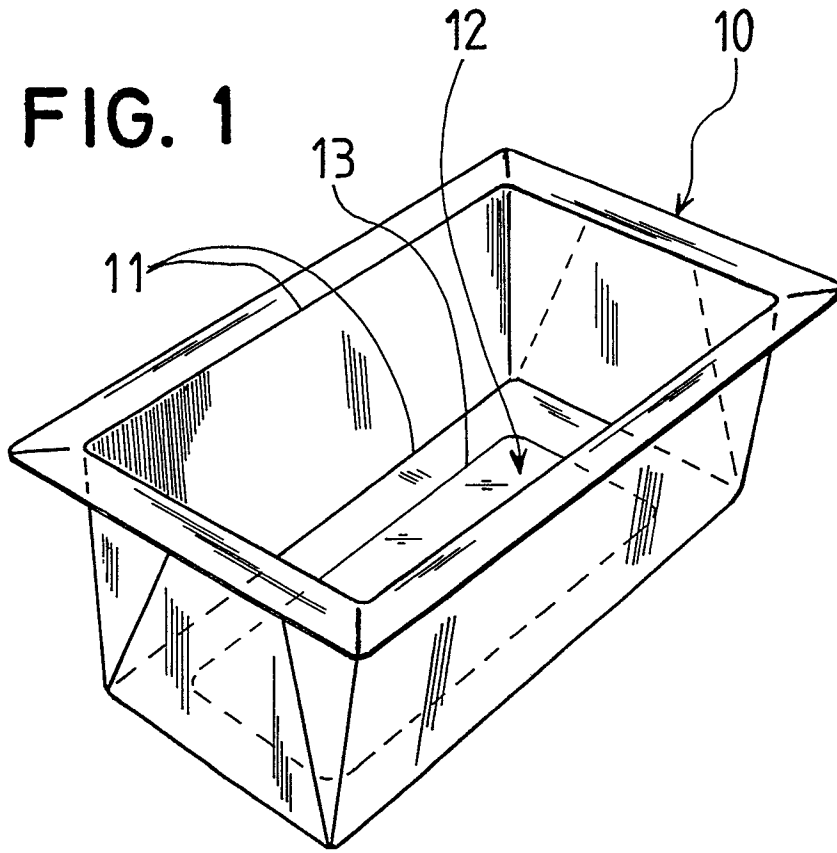

FIG. 2

