



(22) Date de dépôt/Filing Date: 1997/08/15

(41) Mise à la disp. pub./Open to Public Insp.: 1999/02/15

(45) Date de délivrance/Issue Date: 2005/03/29

(51) Cl.Int.<sup>6</sup>/Int.Cl.<sup>6</sup> B23K 37/00

(72) Inventeurs/Inventors:

BENN, ERNIE, CA;  
YUEN, SIMON, CA

(73) Propriétaire/Owner:

SHELL CANADA LIMITED, CA

(74) Agent: SMART & BIGGAR

(54) Titre : REPARATION D'UN POINT FAIBLE DANS LA PAROI D'UN RECIPIENT

(54) Title: REPAIRING A WEAK SPOT IN THE WALL OF A VESSEL

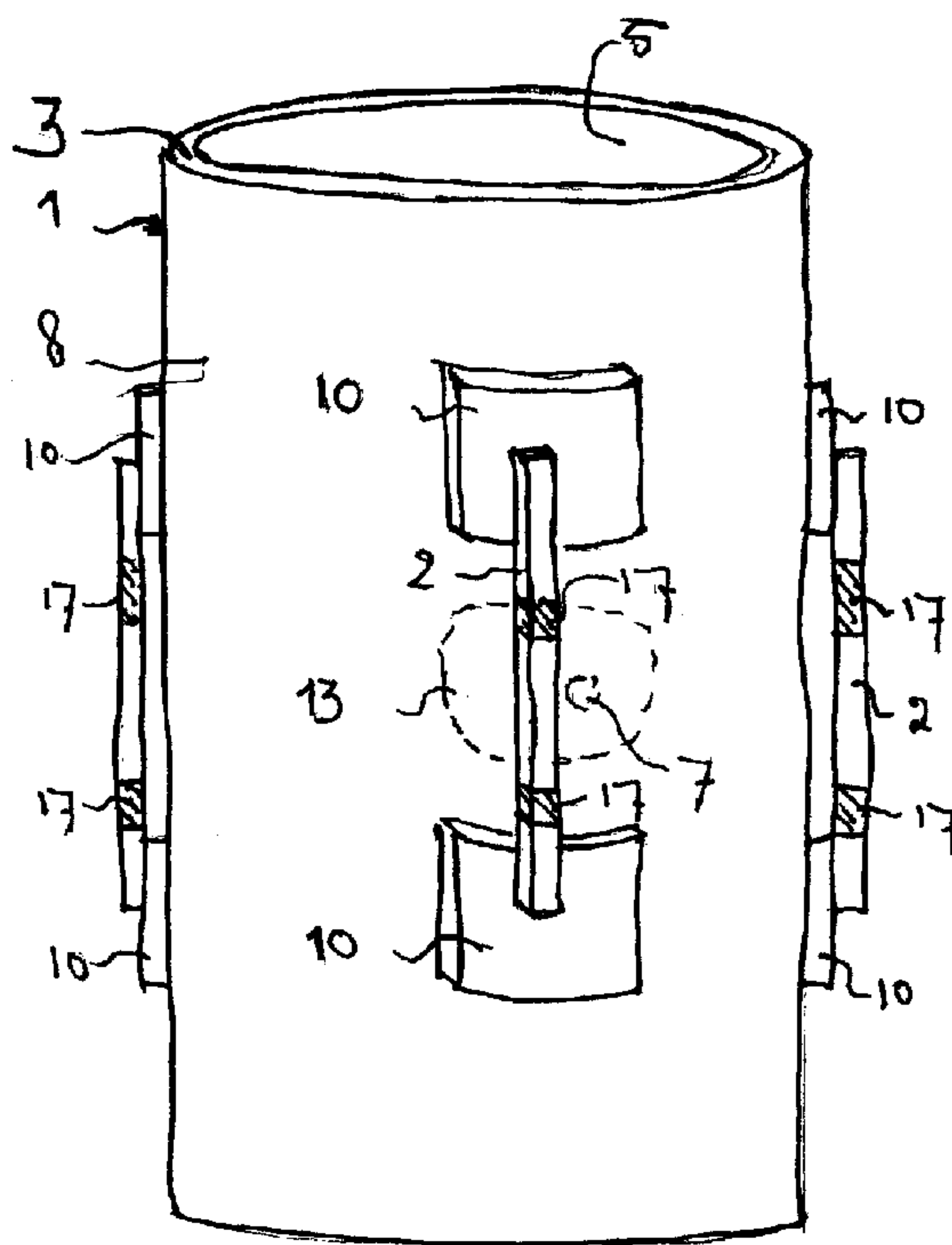

(57) Abrégé/Abstract:

A method of repairing a weak spot (7) in the wall (3) of a vessel (1), which method comprises (a) securing at least one support element (2) to the wall (3) of the vessel (1) in the neighbourhood of the weak spot (7), wherein the ends of the support element(s) (2) are fixed to the wall (3) of the vessel (1); (b) covering the surface of the wall (3) around the weak spot (7) by means of a weld overlay in overlay area (13); (c) causing a support element (2) to elongate by an amount which balances the thermal expansion caused by the welding; and (d) removing the support element (2) after the welding has been substantially completed.

63293-3738

A B S T R A C T

## REPAIRING A WEAK SPOT IN THE WALL OF A VESSEL

A method of repairing a weak spot (7) in the wall (3) of a vessel (1), which method comprises (a) securing at least one support element (2) to the wall (3) of the vessel (1) in the neighbourhood of the weak spot (7), wherein the ends of the support element(s) (2) are fixed to the wall (3) of the vessel (1); (b) covering the surface of the wall (3) around the weak spot (7) by means of a weld overlay in overlay area (13); (c) causing a support element (2) to elongate by an amount which balances the thermal expansion caused by the welding; and (d) removing the support element (2) after the welding has been substantially completed.

63293-3738

- 1 -

## REPAIRING A WEAK SPOT IN THE WALL OF A VESSEL

The present invention relates to repairing a weak spot in the wall of a vessel, such as a distillation column. In particular the present invention relates to repairing the weak spot while the vessel is in place.

5       Such a weak spot is repaired by means of a welded repair, such as an overlay of welding material. The welding material is laid down over the weak spot in several layers until the wall has a sufficient thickness and strength. Laying down the welding material can be  
10       done manually, or by using an automatic welding machine which is mounted in the neighbourhood of the weak spot. Alternatively, the welded repair is effected by removing portions of the vessel wall in the vicinity of the weak spot and inserting metal panels. In some cases, metal  
15       panels may be fixed to the vessel wall over the weak spot.

      When making a welded repair, the heat of the welding is transferred to the wall of the vessel, and thus local hot spots are formed in the wall. This causes local  
20       deformation of the wall, which can cause distortion of the vessel.

      To minimize such distortion, the vessel can be supported with a crane, however, for a very tall vessel, such as a distillation tower, this would require an  
25       expensive tall crane. It may also be impractical or unsafe to use a crane because of the location of the vessel in a plant.

      Applicant had focused on using support elements which

63293-3738

- 2 -

are arranged over the weak spots, and of which the ends are fixed to the wall of the vessel. Such support elements are sometimes called 'strong-backs'. The support elements locally strengthen the wall of the vessel, and support the vessel during the repair. The number of support elements is determined by the amount of support that is required.

An advantage of such support elements is that they are easily applied.

However, a disadvantage is that they also restrict thermal extension of the vessel wall at the place where the welded repair is made which causes high thermal stresses in that part of the wall where the welded repair is made.

It is an object of the present invention to overcome this problem.

To this end a method of repairing a weak spot in the wall of a vessel, which method comprises (a) securing at least one support element having two ends to the wall of the vessel in the neighbourhood of the weak spot, wherein the ends of the support elements(s) are fixed to the wall of the vessel; (b) making a welded repair to the weak spot; (c) causing at least one support element to elongate by an amount which balances the thermal expansion caused by the welding; and (d) removing the support element after the welding has been substantially completed.

The invention will now be described in more detail by way of example with reference to the accompanying Figure showing a perspective view of part of a vessel 1 provided

63293-3738

- 2a -

with support elements 2.

The vessel 1 has a wall 3, and on the inner surface 5 of the wall 3 there is a weak spot 7 which needs to be

- 3 -

repaired.

In accordance with the present invention four support elements 2 are secured to the wall 3 of the vessel 1 in the neighbourhood of the weak spot 7, for the sake of clarity the support element at the back side is not shown. The ends of each support element 2 are fixed to the outer surface 8 of the wall 3 by means of temporary reinforcement pads 10 secured to the wall 3.

With the support elements 2 in place, a welded repair is made on the inner surface of the wall 2 around the weak spot 7 in the form of a weld overlay which is applied in the overlay area 13 which covers the weak spot 7.

The support elements 2 restrict expansion of the wall 3. To reduce thermal stresses, the support elements are elongated by an amount which balances the thermal expansion caused by applying the weld overlay. In order to do so, the support elements 2 are heated which causes them to elongate. In the embodiment shown in the Figure, heating pads 17 are provided which heat the support elements 2 electrically. The elongation which balances the thermal expansion is normally equal to the thermal expansion caused by making the welded repair, however, in some instances the thermal expansion may be selected as slightly larger to put the part of the vessel wall in the vicinity of the weak spot in tension.

When the weld repair in the form of the weld overlay is at least substantially complete, the support elements 2 are removed.

By balancing the elongation the support elements, the thermal stress build-up in the wall of the vessel is reduced in a very simple way.

The number of support elements is suitably between

- 4 -

four and eight, and they are evenly spaced along the circumference of the vessel in axial direction. They can be applied on the outer surface or on the inner surface of the wall.

5           Suitably all support elements are caused to elongate when the weld overlay is being applied, however, for a small overlay area it will only be required to cause the support element adjacent the overlay area to elongate.

10           Causing a support element to elongate can be done by heating the support element. Alternatively this can be done mechanically, and to this end the support element is provided with a hydraulic or mechanical jack, which is activated to elongate the support element.

15           The invention has been described with reference to a welded repair in the form of a weld overlay of welding material. The welding material can be welding rod material for manual welding or welding material from a continuous roll when a welding machine is used. Alternatively, the welded repair can be made to the weak spot by removing part of the vessel wall in the vicinity of the weak spot to make an opening in the wall and by inserting a metal panel or metal panels in the opening. In some cases, a metal panel or metal panels may be fixed to the vessel wall over the weak spot to cover it.

20           Alternatively, the welded repair can be made to the weak spot by removing part of the vessel wall in the vicinity of the weak spot to make an opening in the wall and by inserting a metal panel or metal panels in the opening. In some cases, a metal panel or metal panels may be fixed to the vessel wall over the weak spot to cover it.

25           The invention may also be applied to a vessel which is not in place or which is not vertical.

30           The support elements and the vessel wall can be provided with instruments to determine the stresses in the support elements and the wall of the vessel. The results of the measurements can be used to determine the required elongation of a support element to balance the thermal expansion caused by the welding.

63293-3738

- 5 -

CLAIMS:

1. A method of repairing a weak spot in the wall of a vessel, which method comprises (a) securing at least one support element having two ends to the wall of the vessel in the neighbourhood of the weak spot, wherein the ends of the support elements(s) are fixed to the wall of the vessel; (b) making a welded repair to the weak spot; (c) causing at least one support element to elongate by an amount which balances the thermal expansion caused by the welding; and (d) removing the support element after the welding has been substantially completed.
2. Method of claim 1, wherein the support element is heated to cause it to elongate.
3. Method of claim 1, wherein the support element is provided with a jack which is activated to cause the support element to elongate.
4. Method of claim 1, wherein making the welded repair comprises covering the surface of the wall around the weak spot by means of a weld overlay.
5. Method of claim 1, wherein making the welded repair comprises removing part of the wall surrounding the weak spot and applying a metal panel in the opening.
6. Method of claim 1, wherein making the welded repair comprises applying a metal panel over the weak spot.

SMART & BIGGAR  
OTTAWA, CANADA  
PATENT AGENTS

