



- (51) International Patent Classification:

G01B 9/02 (2006.01)	G02B 6/00 (2006.01)
G01C 3/08 (2006.01)	H01L 31/00 (2006.01)
G01J 9/00 (2006.01)	
- (21) International Application Number: PCT/US2018/040981
- (22) International Filing Date: 06 July 2018 (06.07.2018)
- (25) Filing Language: English
- (26) Publication Language: English
- (30) Priority Data:

15/643,744	07 July 2017 (07.07.2017)	US
------------	---------------------------	----
- (71) Applicant: MEZMERIZ, INC. [US/US]; 33 Thornwood Drive, Suite 100, Ithaca, NY 14850 (US).
- (72) Inventors: DESAI, Shahyaan; 33 Thornwood Drive - Suite 100, Ithaca, NY 14850 (US). LARDIN, Clifford A.; 33 Thornwood Drive - Suite 100, Ithaca, NY 14850 (US). ADAMS, Scott G.; 33 Thornwood Drive - Suite 100, Ithaca, NY 14850 (US).
- (74) Agent: POWERS, Jeffrey B. et al.; Bond, Schoeneck & King PLLC, 350 Linden Oaks, Third Floor, Rochester, NY 14624 (US).
- (81) Designated States (unless otherwise indicated, for every kind of national protection available): AE, AG, AL, AM, AO, AT, AU, AZ, BA, BB, BG, BH, BN, BR, BW, BY, BZ, CA, CH, CL, CN, CO, CR, CU, CZ, DE, DJ, DK, DM, DO, DZ, EC, EE, EG, ES, FI, GB, GD, GE, GH, GM, GT, HN, HR, HU, ID, IL, IN, IR, IS, JO, JP, KE, KG, KH, KN, KP, KR, KW, KZ, LA, LC, LK, LR, LS, LU, LY, MA, MD, ME, MG, MK, MN, MW, MX, MY, MZ, NA, NG, NI, NO, NZ, OM, PA, PE, PG, PH, PL, PT, QA, RO, RS, RU, RW, SA,

(54) Title: PHOTONIC INTEGRATED DISTANCE MEASURING PIXEL AND METHOD OF DISTANCE MEASUREMENT

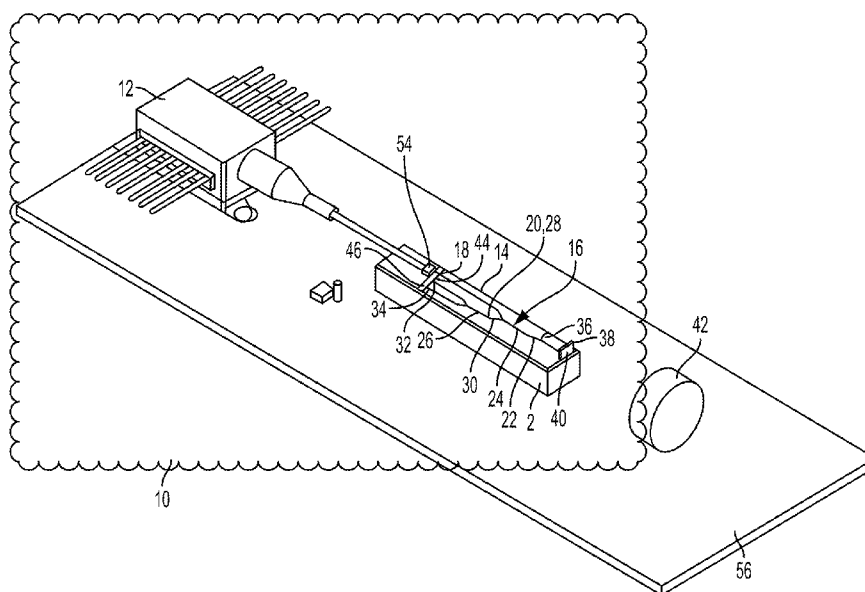

FIG. 1

(57) Abstract: A distance-measuring pixel apparatus includes a photonic integrated circuit disposed on a common substrate that further includes a photonic integrated circuit substrate having disposed thereon two 3 dB directional couplers, a GRIN lens, and a partially reflecting Faraday mirror having a first side that is optomechanically coupled to a second side of the GRIN lens; and a source laser, a first photodetector, and a second photodetector. A related distance measuring method includes, using the distance-measuring pixel apparatus, generating a local oscillator (LO) beam, generating an echo, combining the LO beam and the echo beam, splitting the combined LO beam and the echo beam, and producing a modulation of the photodetector assembly photocurrent at a frequency that encodes the distance of a remote object.



SC, SD, SE, SG, SK, SL, SM, ST, SV, SY, TH, TJ, TM, TN,
TR, TT, TZ, UA, UG, US, UZ, VC, VN, ZA, ZM, ZW.

(84) Designated States (*unless otherwise indicated, for every kind of regional protection available*): ARIPO (BW, GH, GM, KE, LR, LS, MW, MZ, NA, RW, SD, SL, ST, SZ, TZ, UG, ZM, ZW), Eurasian (AM, AZ, BY, KG, KZ, RU, TJ, TM), European (AL, AT, BE, BG, CH, CY, CZ, DE, DK, EE, ES, FI, FR, GB, GR, HR, HU, IE, IS, IT, LT, LU, LV, MC, MK, MT, NL, NO, PL, PT, RO, RS, SE, SI, SK, SM, TR), OAPI (BF, BJ, CF, CG, CI, CM, GA, GN, GQ, GW, KM, ML, MR, NE, SN, TD, TG).

Published:

— *with international search report (Art. 21(3))*

**PHOTONIC INTEGRATED DISTANCE MEASURING PIXEL AND METHOD OF
DISTANCE MEASUREMENT**

RELATED APPLICATION DATA

[0001] The present application claims priority from U.S. Non-Provisional Application No. 15/643,744, filed July 7, 2017, and titled “Photonic Integrated Distance Measuring Pixel and Method of Distance Measurement,” the entirety of which is hereby incorporated by reference.

GOVERNMENT FUNDING

[0002] N/A.

BACKGROUND

[0003] Aspects and embodiments of the invention most generally pertain to distance measuring sensors; more particularly to a chip-scale, distance measuring photonic integrated circuit; and, most particularly to a distance measuring pixel and associated coherent detection method for determining a measured distance from the distance measuring pixel to a remote object.

[0004] Miniaturized imaging systems capable of high precision 3D range measurements are of great interest as sensors in applications such as industrial inspection, construction and architecture, Virtual Reality, and autonomous vehicles. Most systems today are based on the measurement of the time of flight (ToF) of light, phase shift of a time varying light signal, or optical triangulation: either by measuring the distortion of a projected laser pattern on a surface to determine its 3D shape, or using two cameras to simulate stereo vision.

[0005] ToF systems measure the delay between an emitted pulse of light and its reflection from a distant object point to infer its distance. Since the speed of light is a known constant the calculation of distance is trivial based on the time between emitted and received

pulses. However, the major drawbacks of such a system are the need for very high speed precision measurement circuits and large laser emission power required.

[0006] In the phase-shift method, the transmitted light intensity is modulated sinusoidally, and the phase shift of the reflected light signal from round-trip time is used to determine distance. Drawbacks of the phase shift method include range dependence on modulation frequency, susceptibility to crosstalk and noise, and a need to collect many samples to average the error between measurements and recover an accurate distance.

[0007] Both ToF and phase-shift systems need to sweep the spot from one or multiple lasers over a surface to adequately estimate its 3D shape. Current laser scanning range finding systems are expensive due to the need for precision optomechanical assembly, and high resolution motors capable of accurately rotating the laser measurement system and 3D mapping a surface or environment. These systems however, provide the highest resolution of distance measurement and 3D mapping capability over long distance ranges, indoors and outdoors.

[0008] Sensors that employ light patterns are usually smaller and inexpensive. Since they rely on the analysis of distortions in the emitted light patterns to map the shape of a surface they are generally lower in power, do not require the use of high speed precision measurement circuits, and may not need to be mechanically swept over the surface of interest. The major limitations of these sensors are poor range, resolution, and inability to operate in outdoor and bright ambient environments. Both types of devices also suffer from generally slow response.

[0009] A more recent invention is a Photonic Mixing Device (PMD) (US7361883), which is a variant of a radio frequency modulated (RFCW) continuous wave LIDAR. In this sensor the complex electrical mixing circuitry commonly used in RFCW LIDAR is replaced with all optical mixing that occurs within the pixel of a photosensitive semiconductor device.

A modulated light source is used to illuminate a surface. The photosensitive semiconductor surface is electrically modulated at the same frequency as the illumination source and 3D distance is determined by the electro-optical mixing of the two signals.

[0010] Although miniature and inexpensive, the drawback of the PMD device is the need for large pixel sizes to capture adequate reflected light resulting in poor lateral resolution of a depth image. The limited frequency at which the photosensitive semiconductor pixels in the system can be modulated during optical mixing also limits the device's depth measurement resolution. Furthermore, the system is susceptible to saturation from ambient light, which introduces errors in distance measurement.

[0011] Coherent methods for laser ranging, such as frequency modulated continuous wave (FMCW) ranging, which uses optical homodyne detection can provide improvements in range, distance measurement accuracy, and operation in ambient lighting conditions over all of the other light ranging methods described. In such a system, the frequency of emission of the light is linearly modulated and the beam is split into two, wherein one beam is directed towards a measurement target, while the other forms a local oscillator (LO). Light returning from the target is mixed with the LO beam on the surface of a photodetector to provide optical interference patterns which may be processed to provide detailed range information about the target. On a square-law point detector such as a p-i-n photodiode, these interference fringes are manifest as a unique beat frequency, at which the detector's photocurrent is modulated, that is proportional to the modulation frequency of the light as well as the distance to the target. Such systems are described in US7139446B2 and US8687173B2.

[0012] FMCW systems are capable of providing precise distance measurements using low laser power levels. These systems may be coupled to rotating mirrors to scan the light over surfaces and produce range maps of environments. However, such systems are usually

relatively expensive due to the complexity of the optical architecture and precise optical tolerances required in embodiments using free-space optics. Embodiments of such systems may also be implemented using fiber optic components, however these tend to be bulky and only slightly less complicated than free-space designs to manufacture.

[0013] What is needed therefore, is a distance measuring sensor that does not trade off measurement resolution and cost, is not susceptible to environmental artifacts, retains a compact size, and can be manufactured inexpensively. The following disclosure describes an FMCW distance measurement sensor that meets these requirements.

SUMMARY

[0014] The present disclosure is directed to a photonic integrated distance measuring pixel and method of distance Measurement.

[0015] According to an aspect is a distance-measuring pixel apparatus, comprising (a) a photonic integrated circuit disposed on a common substrate, comprising (i) a photonic integrated circuit substrate having disposed thereon, (ii) a first 3 dB directional coupler having first and second output ports and first and second input ports; (iii) a second 3 dB directional coupler having first and second output ports and first and second input ports, wherein the second input port of the first 3 dB directional coupler is directly optically coupled to the first input port of the second 3 dB directional coupler; (b) a GRIN lens having a first side that is optomechanically coupled to the first output port of the first 3 dB directional coupler; (c) a partially reflecting Faraday mirror having a first side that is optomechanically coupled to a second side of the GRIN lens; (d) a source laser having an output that is optically coupled to the first input port of the first 3 dB directional coupler; (e) a first photodetector optomechanically coupled to the first output port of the second 3 dB directional coupler; and (f) a second photodetector optomechanically coupled to the second output port of the second 3 dB directional coupler.

[0016] According to an embodiment, the second output port of the first directional coupler and the second input port of the second directional coupler in the pixel apparatus are optically terminated.

[0017] According to another embodiment, the source laser is a laser diode.

[0018] According to another embodiment, the source laser output is linearly polarized.

[0019] According to another embodiment, the source laser output is in the near infrared, mid infrared, or long wave infrared spectral regions.

[0020] According to another embodiment, the source laser output is linearly chirped.

[0021] According to another embodiment, the source laser is a distributed feedback (DFB) or distributed Bragg Reflector (DBR) laser with linewidths of ≤ 1 MHz.

[0022] According to another embodiment, the source laser output is in a frequency modulated continuous wave format.

[0023] According to another embodiment, the GRIN lens is in the form of a rod.

[0024] According to another embodiment, the first and second photodetectors are electrically configured to perform autobalanced, differential signal detection.

[0025] According to another embodiment, the partially reflecting Faraday mirror reflects between 0.1%, to 50% of the light emitted from the first output port of the first 3 dB directional coupler.

[0026] According to another embodiment, the pixel apparatus further comprises an optical isolator disposed between the source laser and the photonic integrated circuit.

[0027] According to another embodiment, the source laser and the photonic integrated circuit are disposed on a common substrate.

[0028] According to another embodiment, the photodetectors are integrally fabricated within the photonic integrated circuit.

[0029] According to another embodiment, the pixel apparatus further comprises a light focusing component disposed optically downstream of the partial Faraday mirror.

[0030] According to another aspect, a method of measuring distance between a distance measuring pixel and a remote object, comprises (a) providing a distance measuring pixel apparatus as set forth in claim 1;

producing a frequency modulated light beam from the source laser; (b) coupling the frequency modulated light beam from the source laser into the first input port of the first 3 dB bidirectional coupler such that half the light is extinguished at the second output port of the first 3 dB bidirectional coupler, while the remainder is output at the first output port of the first 3 dB bidirectional coupler; (c) collecting a predetermined fraction of the light reflected from the partial Faraday mirror back into the GRIN lens and into the first output port of the first directional coupler to form a local oscillator (LO) light beam; (d) transmitting the remaining frequency modulated light beam through the partial Faraday mirror and towards a focusing optical component, which gradually focuses the light; (e) collecting light reflected from the remote object intersecting the gradually focused light using the focusing optical component, through the partial Faraday mirror, into the GRIN lens and subsequently into the first output port of the first bidirectional coupler, to form an echo light beam; (f) directing the combined LO and echo light beams towards the first input port of the second 3 dB bidirectional coupler where it is split equally at the two output ports of the second directional coupler; and (g) delivering the combined LO and echo beams at each output port of the second directional coupler onto the surface of a photodetector, wherein the optical mixing of the LO and echo signals produces a modulation of the photocurrent of each photodetector at a frequency that encodes the distance of the echo.

[0031] These and other aspects of the invention will be apparent from the embodiments described below.

Brief Description of the Drawings

[0032] FIG. 1 schematically shows a distance measuring pixel in accordance with an embodiment of the invention.

[0033] FIG. 2 schematically shows a photonic integrated circuit section forming a distance measuring pixel, in accordance with an embodiment of the invention.

[0034] FIGS. 3A-3C schematically show three approaches for optomechanical coupling between a laser and the photonic integrated circuit, according to illustrative embodiments of the invention.

[0035] FIGS. 4A-4B schematically show different approaches for optomechanical coupling between photodetectors and the photonic integrated circuit, according to illustrative embodiments of the invention.

[0036] FIGS. 5 schematically illustrates a frequency modulated continuous wave (FMCW) method of detecting distance and the relationship between detected distance and distance resolution, according to illustrative embodiments of the invention.

[0037] FIG. 6 schematically shows the light path from the distance measuring pixel to the remote object and back, highlighting a noise reduction feature, in accordance with an embodiment of the invention.

[0038] FIG. 7A schematically shows a 3D scanning and mapping system comprising the distance measuring pixel optomechanically coupled to a composite scanning MEMS mirror capable of scanning light along two mutually orthogonal axes; FIG. 7B schematically shows a similar system with a composite scanning MEMS mirror capable of scanning light along one axis, placed in a housing mechanically coupled to a motor capable of rotating the housing along a second orthogonal axis, according to exemplary embodiments of the invention.

[0039] FIG. 8 schematically shows a 3D scanning and mapping system comprised of the distance measuring pixel optomechanically coupled to a mirror that is mechanically coupled to a motor capable of rotating along one axis, and placed within a housing that is mechanically coupled to a second motor capable of rotating along a second mutually orthogonal axis, according to an exemplary embodiment of the invention.

Detailed Description of Non-limiting, Exemplary Embodiments

[0040] In the following description, numerous specific details are set forth to clearly describe various specific embodiments disclosed herein. One skilled in the art will understand that the presently claimed invention may be practiced without all of the specific details discussed below.

[0041] FIGS. 1 and 2 show a distance measuring pixel **10**. The laser which may not be on same substrate as the photonic circuit as is shown in Fig 1 is a single frequency laser diode **12**, which may emit linearly polarized radiation in the near infrared, mid infrared, or long wave infrared spectral regions, and made to chirp; i.e., be tuned to emit radiation at a range of frequencies centered around a center frequency by modulating the laser's injection current, temperature, bias current of the gain medium, cavity length or a combination of all four. The modulation waveform is controlled to ensure that the emission frequency of the laser is modulated linearly over a time period. The laser **12** is optomechanically coupled to a photonic integrated circuit **14** (shown in greater detail in FIG. 2) comprising waveguides that can propagate the emitted laser radiation, and configured to form a first 3 *dB* directional coupler **16** with a first input port **18**, a second input port **20**, a first output port **22**, a second output port **24**; a second 3 *dB* directional coupler **26** with a first input port **28**, a second input port **30**, a first output port **32**, a second output port **34**. Light from the laser **12** is routed into the first input port **18** of the first directional coupler **16** such that an equal fraction of the light is routed towards the second output port **24** where it is extinguished by the appropriate

termination of the second input port **24**, while the other half of the light is routed into the first output port **22** where it is emitted.

[0042] A gradient index (GRIN) rod lens **36** to effectively couple light between the waveguide and free-space is optomechanically coupled to the first output port **22** of the first directional coupler **16**, which routes the emitted laser light towards a partial Faraday mirror **38** that is optomechanically coupled to the gradient index rod lens **36**. The partial Faraday mirror is formed by coating a magneto-optical material on the surface facing away from the gradient index rod lens with a material **40** that reflects a predetermined fraction of the laser radiation back towards the gradient index rod lens, while the rest of the laser radiation is transmitted towards focusing optics **42** that relay the light towards a remote object. The fraction of light reflected may be between 0.1%, up to 50% of the laser radiation emitted at port **22**. The reflected light from the partial Faraday mirror **38** becomes a local oscillator (LO) signal.

[0043] The light reflected from the remote object is collected back into the focusing optics **42**, through the partial Faraday mirror **38** and gradient index rod lens **36** and routed into the first output port **22** of the first directional coupler **16** as an echo signal. The first output port **22** of the first directional coupler **16** simultaneously contains the LO and echo light beams. Half the combined LO and echo signal is routed back towards the first input port **18** where it may be extinguished by an optical isolator **54** placed between the laser **12** and the input port **18** of the first directional coupler. The other half of the combined LO and echo signal is routed towards the second input port **20** of the first directional coupler, which corresponds with the first input port **28** of the second directional coupler **26**. An equal fraction of the combined LO and echo light signal in the second directional coupler **26** is routed to the first and second output ports **32** and **34**. By virtue of the evanescent wave coupling between the light signals in the two output ports **32** and **34**, each carries one quarter

the original combined LO and echo signal that are optically phase shifted by 90° relative to each other. Photodetectors **44** and **46**, with a spectral response at the emission wavelength of laser **12**, are connected to output ports **32** and **34** such that the optical mixing of the combined LO and echo light signal on the photodetector surface produces a modulation of the photocurrent of each detector **44** and **46** at a frequency that encodes the distance of the echo light signal's origin relative to the distance measuring pixel. This method of distance measurement is detailed in FIGS. 5 and 6.

[0044] FIG. 2 shows the photonic integrated circuit in greater detail. The GRIN rod lens **36** and partial Faraday mirror **38** may be integrated within the photonic circuit using silicon optical bench technology. Using semiconductor fabrication methods, very precise grooves and alignment holes may be formed on the photonic integrated circuit substrate **2** into which the free space optical components such as the gradient index rod lens **36**, partial Faraday mirror **38** can be placed. The photonic circuit substrate may also integrate an optical isolator **54**. The waveguides for the 3 *dB* couplers may be formed on a substrate such as silicon or glass using appropriate material layers transparent to the laser radiation. For example, Si_3N_4 , and SiO_2 can be used as the core and cladding materials in the near-infrared through long-wave infrared spectrum, while Si and SiO_2 can be used for core/cladding layers in the near-to-mid infrared spectrum.

[0045] FIGS. 3A-3C show various methods that may be used to optomechanically couple the laser **12** to the photonic integrated circuit **14**. Laser **12** may advantageously be a distributed feedback (DFB) or distributed Bragg Reflector (DBR) laser with linewidths of ≤ 1 MHz in a package separate to the photonic circuit **14** and coupled to the first input port **18** of directional coupler **16** using a polarization maintaining fiber pigtail **50** with the polished fiber face butt-coupled to the input port **18** as shown in FIG. 3A. Laser **12** may contain an

integrated optical isolator, and the laser package as well as the photonic circuit may be co-located on a planar rigid substrate **56**.

[0046] Alternatively, a laser die **100** may be prefabricated on its own respective substrate material and bonded to the photonic circuit substrate as shown in FIG. 3B, and may be optically coupled to the input waveguide port **18** using either butt-coupling or evanescent coupling, which are well developed in the art. The laser **102** may also be formed directly in the photonic circuit by bonding the laser gain medium such as a III-V semiconductor material **104** to the photonic circuit substrate **2** into which the laser cavity has been formed as described in US8620164 as shown in FIG. 3C.

[0047] Similarly, FIG. 4A and FIG. 4B show the various optomechanical coupling methods between the photodetectors **44** and **46** and the photonic circuit **14**. The photodetectors may be packaged in an assembly along with signal amplification circuits on a rigid printed circuit board **52**. Photonic circuit **14** may be aligned so that the output ports **32** and **34** are aligned and butt-coupled to the photodetector surface, and bonded to the printed circuit board **52**. Fiber pigtailed may also be employed as the optical coupling between the output ports **32** and **34**.

[0048] Alternatively, the photodetectors may be formed directly as part of the photonic circuit, either by appropriately doping the substrate material with impurity materials, or *via* the deposition of epitaxial films of photosensitive material with a spectral response to the laser radiation. These materials may include Si, InGaAs, and Ge. Photodetectors **44** and **46** may be electrically connected in a balanced configuration such that their photocurrents cancel. In this case, it is necessary to equalize the DC optical power impinging upon each photodiode. When this is done, the effective output of the balanced pair of photodiodes is zero until there is some difference in the intensity of one of the beams. When this occurs, it causes the pair to become “unbalanced” and a net signal appears on the

output. To avoid the often tedious, manual task of balancing the intensities of the two beams, an auto-balancing circuit can be employed).

[0049] FIG. 5 provides further details on the distance measuring method employed within the distance measuring pixel. The laser **12** is modulated in a frequency modulated continuous wave format (FMCW) wherein the instantaneous frequency of optical radiation is periodically shifted by dF . The periodic and linear frequency chirp may practically be performed by applying a saw-tooth modulation to the injection current, junction temperature, bias current of the gain region, or any combinations of these methods. The laser output passes an optical isolator **54** to avoid deterioration from reflections back into the laser cavity. Combining or optically mixing the reflected chirped echo light from a remote object and the chirped LO light reflected from the partial Faraday mirror **38** onto the surface of photodetectors **44** and **46** produces a modulation of the photocurrent of each detector at a ‘beat’ frequency that is the difference of the frequency chirp pulse reflected from the Faraday mirror; i.e., the LO signal and the echo signal reflected from the object. The frequency of the beat tone generated from the optical mixing process on the photodetector is proportional to the target distance, the frequency chirp, and chirp time as described by the range resolution (dR) equation of an FMCW system:

$$dR = c/2dF,$$

where c is the speed of light in air and dF is the frequency chirp within the laser pulse. The beat frequency tone produced is a function of the linear frequency modulated chirp dF of the laser, the chirp pulse duration Tp , and range D :

$$Fb = (dF/Tp) * (2D/c),$$

where Fb is the beat frequency, and c is the speed of light in air.

[0050] Following the optical mixing of the LO and echo light signals on the photodetectors **44** and **46**, a post detection processing may be performed by electronic

circuitry **60**, which may include time averaging, band pass filtering (BPF), FMCW demodulation, amplification, analog to digital conversion, and fast Fourier Transform (FFT) processing to decode the distance encoded within the beat frequency. All or part of the set of these components may be incorporated into the photonic circuit, or as a subsystem co-located with the photonic circuit on a separate rigid substrate along with the photonic circuit such as a printed circuit board.

[0051] FIG. 6 highlights the method by which the present invention reduces the effect of the spurious signals from the environment, and back reflections from optical interfaces within the photonic circuit. Linearly polarized light **90** output at the first output port **22** of the first 3 *dB* coupler **16** passes through the gradient index rod lens **36** and is routed towards the partial Faraday mirror **38**. Passing through the magneto-optical material, the linearly polarized light undergoes a 45° clockwise polarization rotation and becomes right circularly polarized before a predetermined fraction is reflected to form the LO signal. The reflected light **92** makes a second pass through the magneto-optical material and undergoes another 45° clockwise polarization and emerges from the partial Faraday mirror with a polarization orthogonal to the original linear polarization, and is routed back into the first input port **22** of the first 3 *dB* coupler *via* the gradient index rod lens **36**. In a similar manner, the fraction of light **94** transmitted through the partial Faraday mirror **38** emerges from the distance measuring pixel towards an object with right circular polarization. Upon reflection from the object, provided the object is not birefringent, the reflected echo light **94** retains its right circular polarization and is collected back towards partial Faraday mirror **38**. The fraction of echo light transmitted through partial Faraday mirror also makes a second pass through the magneto-optical material and acquires another 45° clockwise polarization rotation, to match the polarization state of the LO signal. Both LO and echo signals with the same polarization states are now routed back into the photonic circuit as described previously and mixed on the

surface of each of the two photodetectors **44** and **46** to produce a beat frequency that encodes the distance of the echo signal. It is well understood in the field that mixing of light signals with the same polarization occurs with greater efficiency than signals with orthogonal polarization states. Back reflections from the optical interfaces within the photonic circuit such as for example a Fresnel reflection that may occur between the first output port **22** of first directional coupler **16** and the gradient index rod lens do not make a double pass through partial Faraday mirror and so do not have their polarization state rotated. Consequently their mixing efficiency with the orthogonally polarized LO light signal is greatly reduced, and hence any spurious beat frequencies generated are minimized. The embodied invention ensures that the LO and echo light signals have the same polarization state, further ensuring that the desired beat frequency measured at the photodetectors will have the largest amplitude.

[0052] The distance measuring pixel **10** forms an ultraminiature, range finding system that can accurately measure distance, but does not require expensive optics, electronic circuits, and optical alignment steps in fabrication as is the case for existing high precision FMCW and other laser ranging systems. Advantageously, a single distance measuring pixel may be coupled with a composite MEMS scanning mirror **70** to create a very inexpensive, wide field of view ($> 120^\circ$) 3D laser scanning and mapping system as shown in FIGS. 7A and 7B. The MEMS mirror may be capable of oscillating or rotating along two independent axes **120** and **122** and may be placed so that at least one rotation axis of the mirror **70** is at a 45° angle to the optical axis of the distance measuring pixel as shown in FIG. 7A. The arrangement described herein is meant only to illustrate a simple exemplary arrangement. It will be readily apparent to one skilled in the art that other optical arrangements may be used to couple light between the MEMS **70** and distance measuring pixel **10**. The MEMS mirror **70** scans the chirped laser light **94** output from the distance measuring pixel over a target

object, and redirects the reflected echo light **96** back towards the pixel. By raster scanning the laser beam along two mutually orthogonal axes, a 3D map of the object may be created.

[0053] Alternatively, a similarly inexpensive, high performance 3D scanning and mapping system may be created using the distance measuring pixel **10** of the present invention. It may be coupled to a MEMS mirror **72** capable of oscillating along a first axis **128** as shown in FIG. 7B. The distance measuring pixel **10** and MEMS mirror **72** may be co-located on a common rigid substrate **56**, and placed within a housing **74** that is mechanically coupled to a miniature motor **76** capable of precisely rotating the distance measuring pixel and MEMS assembly along a second axis **130** that is orthogonal to the axis of rotation of the MEMS mirror. Such a system may be capable of scanning over a 360° field of view in at least one dimension.

[0054] FIG. 8 shows another embodiment of a 3D scanning and mapping system using distance measuring pixel **10**. In this arrangement, chirped laser light emitted from the distance measuring pixel **10** is scanned along a first axis **132** using a mirror **80** mechanically coupled to a miniature motor **82**. Mirror **80** may have an elliptically shaped face and is mechanically coupled to motor **82** such that the elliptical face is at 45° to the axis of rotation of motor **82**. The mirror and motor assembly are arranged relative to the distance measuring pixel such that the optical axis of the distance measuring pixel and focusing optics is collinear with the axis of rotation of motor **82**. Distance measuring pixel **10**, mirror **80** and motor **82** may be placed within housing **84** that is mechanically coupled to a second motor **86** capable of rotating along a second axis **134** that may be orthogonal to the rotation axis of motor **82**, to create a 3D scanning and mapping system with a field of view of 360° in at least one dimension.

[0055] The systems described in FIGS. 7A-7B and FIG. 8 have a total volume < 600 cm³, which is substantially less than that of existing laser scanning systems. The size of the

mirror aperture may depend on the desired range at which the system is designed to perform distance measurements. Measurements over longer distance ranges require greater light collection capability and hence larger mirror apertures. Diameters of 1 - 10 millimeters may be suitable mirror sizes for maximum ranges between 10 meters and 150 meters with a range resolution of ≤ 1 centimeter. The laser wavelength may advantageously be ≥ 1300 nm, with a CW output power of ≤ 100 mW.

[0056] The advantages of the disclosed distance measuring pixel **10** and 3D scanning and mapping systems arrangements based on distance measuring pixel compared with current state of the art 3D laser scanning and mapping systems are: (1) A factor of 10^3 reduction in volume, (2) A factor of 10 less expensive, (3) No critical optical alignment required, (4) Vibration resistance, (5) Greater immunity to back reflections and stray light from the environment. Furthermore, another salient feature of a distance measuring pixel/MEMS mirror 3D scanning and mapping system is the ability to program the MEMS to scan in optimized 2D patterns to first do a cursory scan of the overall target area, and then selectively focus on specific areas of the target for improved resolution and/or higher signal-to-noise ratio.

[0057] Having now described the invention in accordance with the requirements of the patent statutes, those skilled in this art will understand how to make changes and modifications to the present invention to meet their specific requirements or conditions. Such changes and modifications may be made without departing from the scope and spirit of the invention as disclosed herein.

[0058] The foregoing Detailed Description of exemplary embodiments is presented for purposes of illustration and disclosure in accordance with the requirements of the law. It is not intended to be exhaustive nor to limit the invention to the precise form(s) described, but only to enable others skilled in the art to understand how the invention may be suited for a

particular use or implementation. The possibility of modifications and variations will be apparent to practitioners skilled in the art. No limitation is intended by the description of exemplary embodiments, which may have included tolerances, feature dimensions, specific operating conditions, engineering specifications, or the like, and which may vary between implementations or with changes to the state of the art, and no limitation should be implied therefrom. Applicant has made this disclosure with respect to the current state of the art, but also contemplates advancements and that adaptations in the future may take into consideration of those advancements, namely in accordance with the then current state of the art. It is intended that the scope of the invention be defined by the claims as written and equivalents as applicable. Reference to a claim element in the singular is not intended to mean “one and only one” unless explicitly so stated. Moreover, no element, component, nor method or process step in this disclosure is intended to be dedicated to the public regardless of whether the element, component, or step is explicitly recited in the Claims. No claim element herein is to be construed under the provisions of 35 U.S.C. Sec. 112, sixth paragraph, unless the element is expressly recited using the phrase “means for ...” and no method or process step herein is to be construed under those provisions unless the step, or steps, are expressly recited using the phrase “comprising the step(s) of”

We claim:

1. A distance-measuring pixel apparatus, comprising:
 - a photonic integrated circuit disposed on a common substrate,
 - comprising:
 - a photonic integrated circuit substrate having disposed thereon,
 - a first 3 dB directional coupler having first and second output ports and first and second input ports;
 - a second 3 dB directional coupler having first and second output ports and first and second input ports,
 - wherein the second input port of the first 3 dB directional coupler is directly optically coupled to the first input port of the second 3 dB directional coupler;
 - a GRIN lens having a first side that is optomechanically coupled to the first output port of the first 3 dB directional coupler;
 - a partially reflecting Faraday mirror having a first side that is optomechanically coupled to a second side of the GRIN lens;
 - a source laser having an output that is optically coupled to the first input port of the first 3 dB directional coupler;
 - a first photodetector optomechanically coupled to the first output port of the second 3 dB directional coupler; and
 - a second photodetector optomechanically coupled to the second output port of the second 3 dB directional coupler.
2. The pixel apparatus of claim 1, wherein the second output port of the first directional coupler and the second input port of the second directional coupler are optically terminated.
3. The pixel apparatus of claim 1, wherein the source laser is a laser diode.
4. The pixel apparatus of claim 1, wherein the source laser output is linearly polarized.

5. The pixel apparatus of claim 1, wherein the source laser output is in the near infrared, mid infrared, or long wave infrared spectral regions.
6. The pixel apparatus of claim 1, wherein the source laser output is linearly chirped.
7. The pixel apparatus of claim 1, wherein the source laser is a distributed feedback (DFB) or distributed Bragg Reflector (DBR) laser with linewidths of ≤ 1 MHz.
8. The pixel apparatus of claim 1, wherein the source laser output is in a frequency modulated continuous wave format.
9. The pixel apparatus of claim 1, wherein the GRIN lens is in the form of a rod.
10. The pixel apparatus of claim 1, wherein the first and second photodetectors are electrically configured to perform autobalanced, differential signal detection.
11. The pixel apparatus of claim 1, wherein the partially reflecting Faraday mirror reflects between 0.1%, to 50% of the light emitted from the first output port of the first 3 dB directional coupler.
12. The pixel apparatus of claim 1, further comprising an optical isolator disposed between the source laser and the photonic integrated circuit.
13. The pixel apparatus of claim 1, wherein the source laser and the photonic integrated circuit are disposed on a common substrate.
14. The pixel apparatus of claim 1, wherein the photodetectors are integrally fabricated within the photonic integrated circuit.
15. The pixel apparatus of claim 1, further comprising a light focusing component disposed optically downstream of the partial Faraday mirror.
16. The pixel apparatus of claim 15, further comprising:
 - a mirror;
 - a first motor mechanically coupled to the mirror and configured to provide a rotation about a first axis;

a housing in which the first motor is disposed; and

a second motor mechanically coupled to the housing and configured to provide a rotation about a second axis that is different than the first axis.

17. The pixel apparatus of claim 15, further comprising a composite scanning MEMS mirror capable of oscillating along one or more axes, disposed on the common substrate.

18. The pixel apparatus of claim 17, further comprising:

a housing on which the common substrate is disposed; and

a motor configured to provide a rotation about an axis, mechanically coupled to the housing.

19. A method of measuring distance between a distance measuring pixel and a remote object, comprising:

providing a distance measuring pixel apparatus as set forth in claim 1;

producing a frequency modulated light beam from the source laser;

coupling the frequency modulated light beam from the source laser into the first input port of the first 3 dB bidirectional coupler such that half the light is extinguished at the second output port of the first 3 dB bidirectional coupler, while the remainder is output at the first output port of the first 3 dB bidirectional coupler;

collecting a predetermined fraction of the light reflected from the partial Faraday mirror back into the GRIN lens and into the first output port of the first directional coupler to form a local oscillator (LO) light beam;

transmitting the remaining frequency modulated light beam through the partial Faraday mirror and towards a focusing optical component, which gradually focuses the light;

collecting light reflected from the remote object intersecting the gradually focused light using the focusing optical component, through the partial Faraday mirror, into the GRIN lens and subsequently into the first output port of the first bidirectional coupler, to form an echo light beam;

directing the combined LO and echo light beams towards the first input port of the second 3 dB bidirectional coupler where it is split equally at the two output ports of the second directional coupler;

delivering the combined LO and echo beams at each output port of the second directional coupler onto the surface of a photodetector, wherein the optical mixing of the LO and echo signals produces a modulation of the photocurrent of each photodetector at a frequency that encodes the distance of the echo.

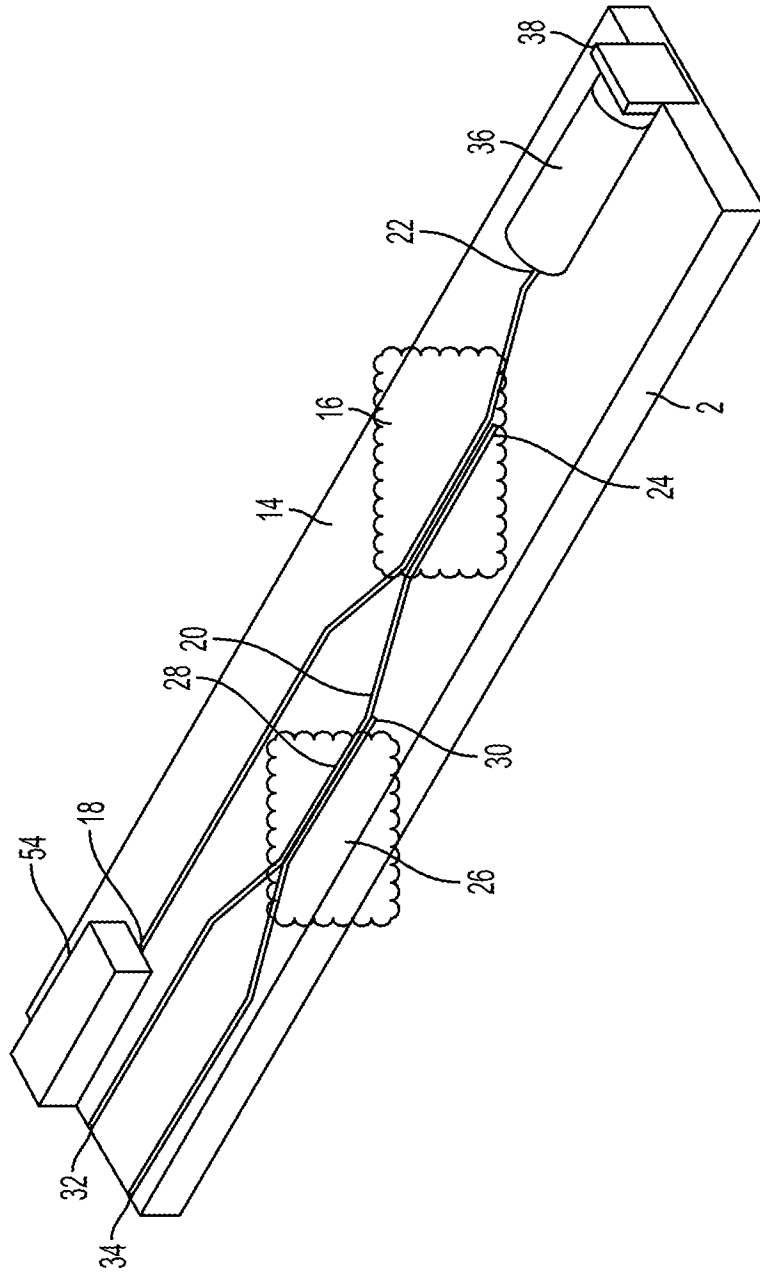

FIG. 2

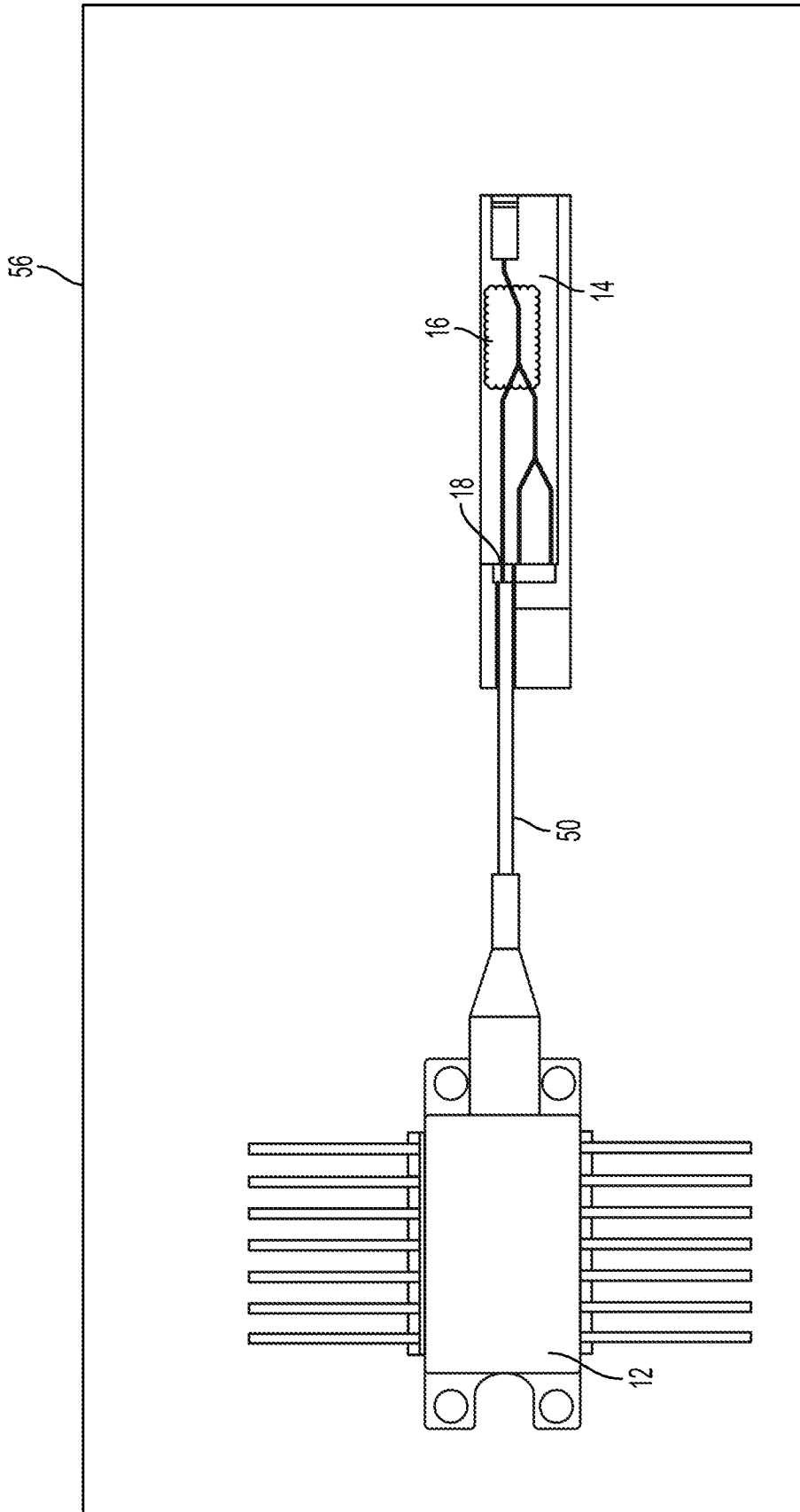

FIG. 3A

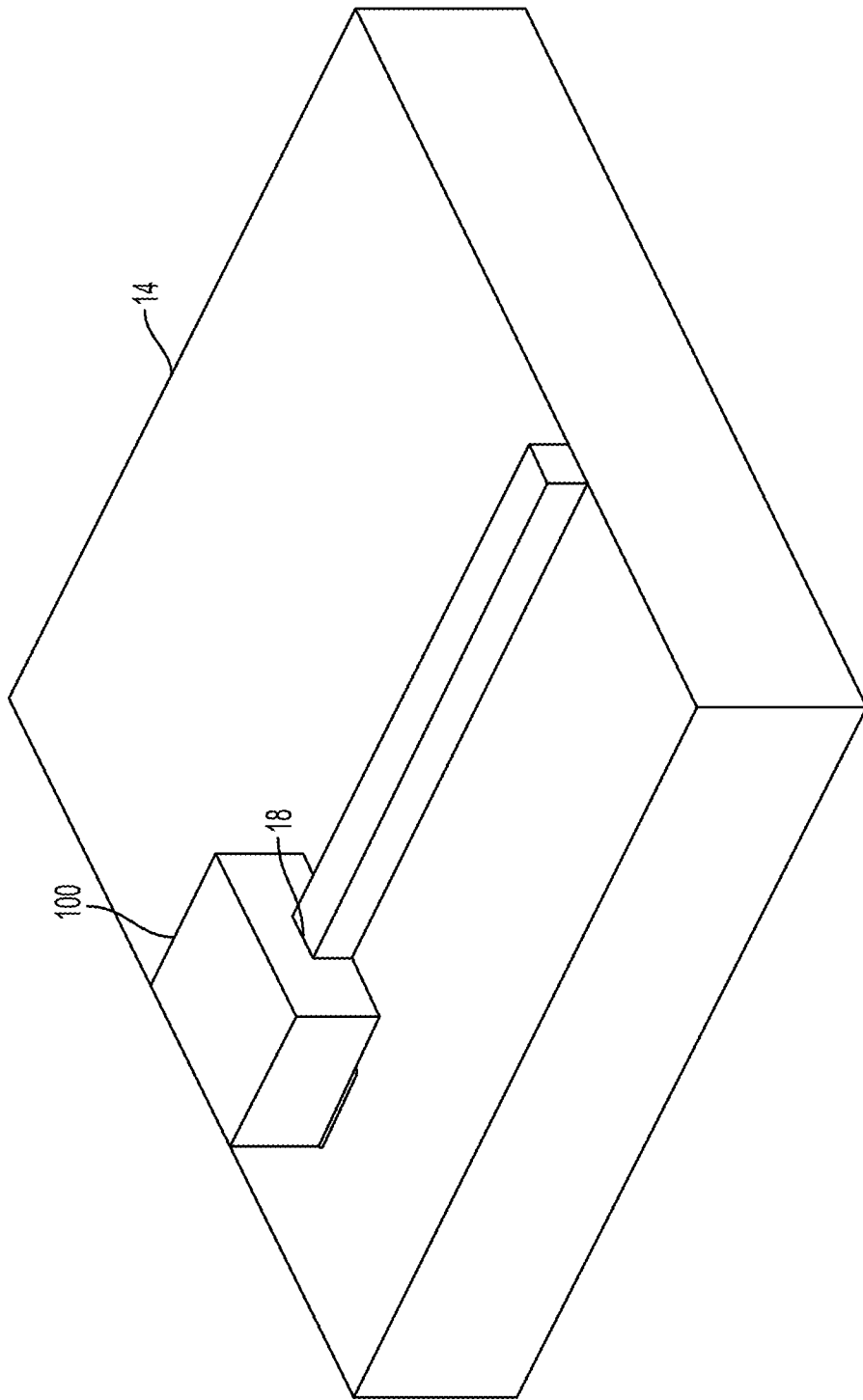

FIG. 3B

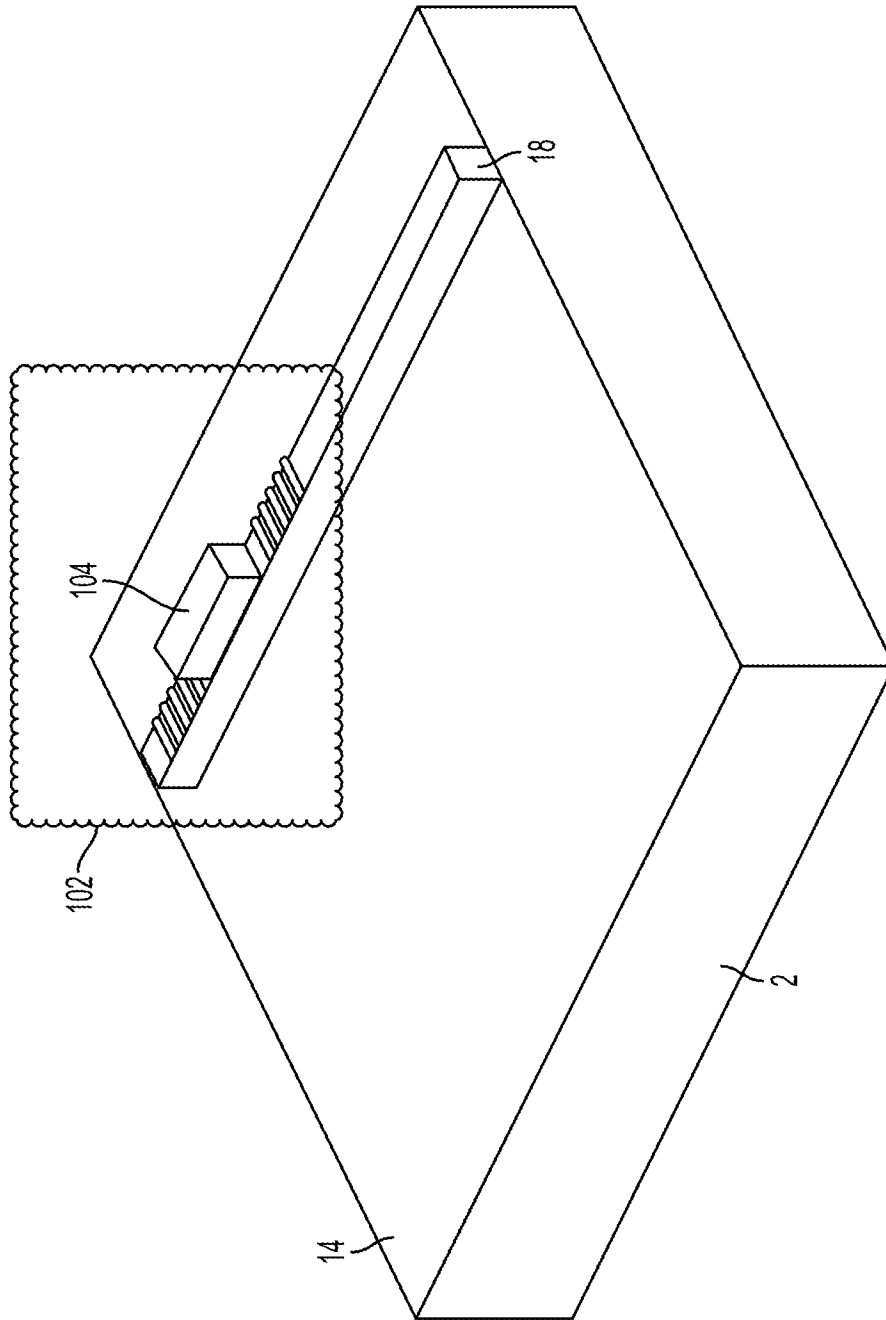

FIG. 3C

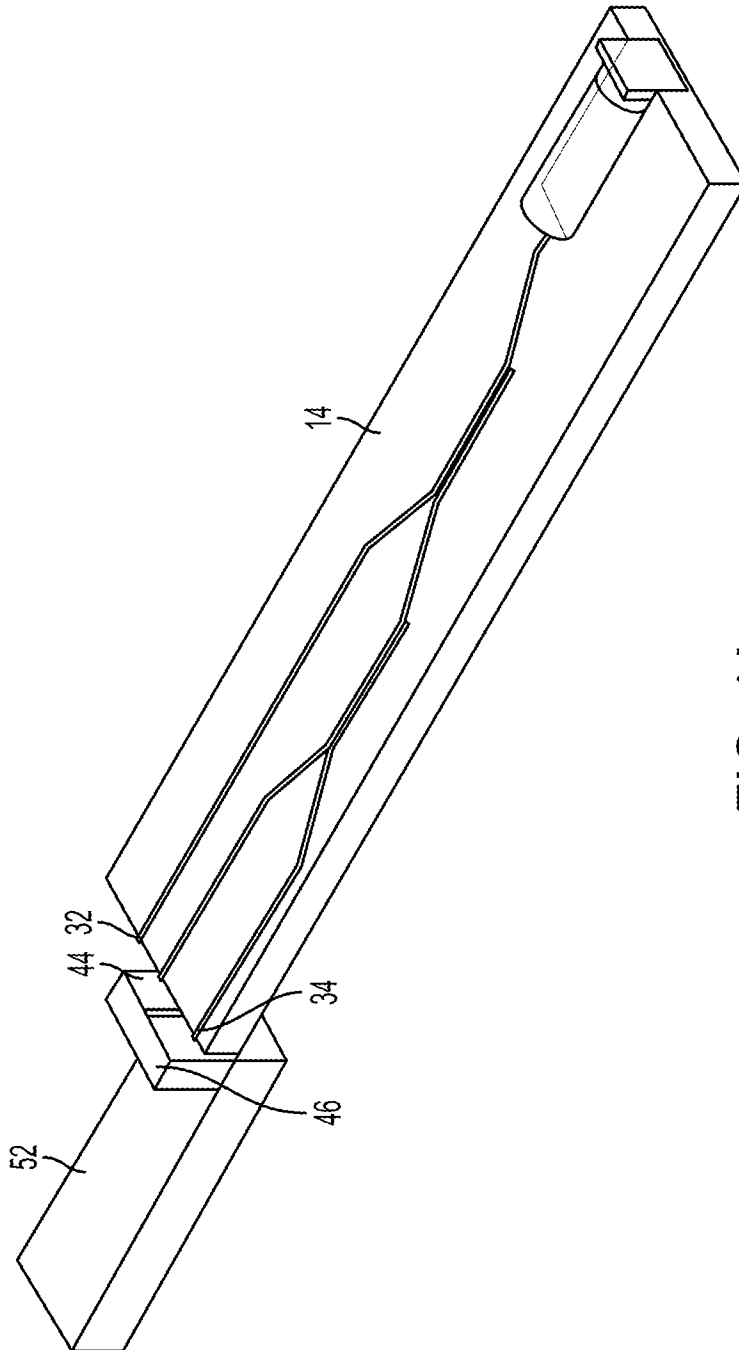

FIG. 4A

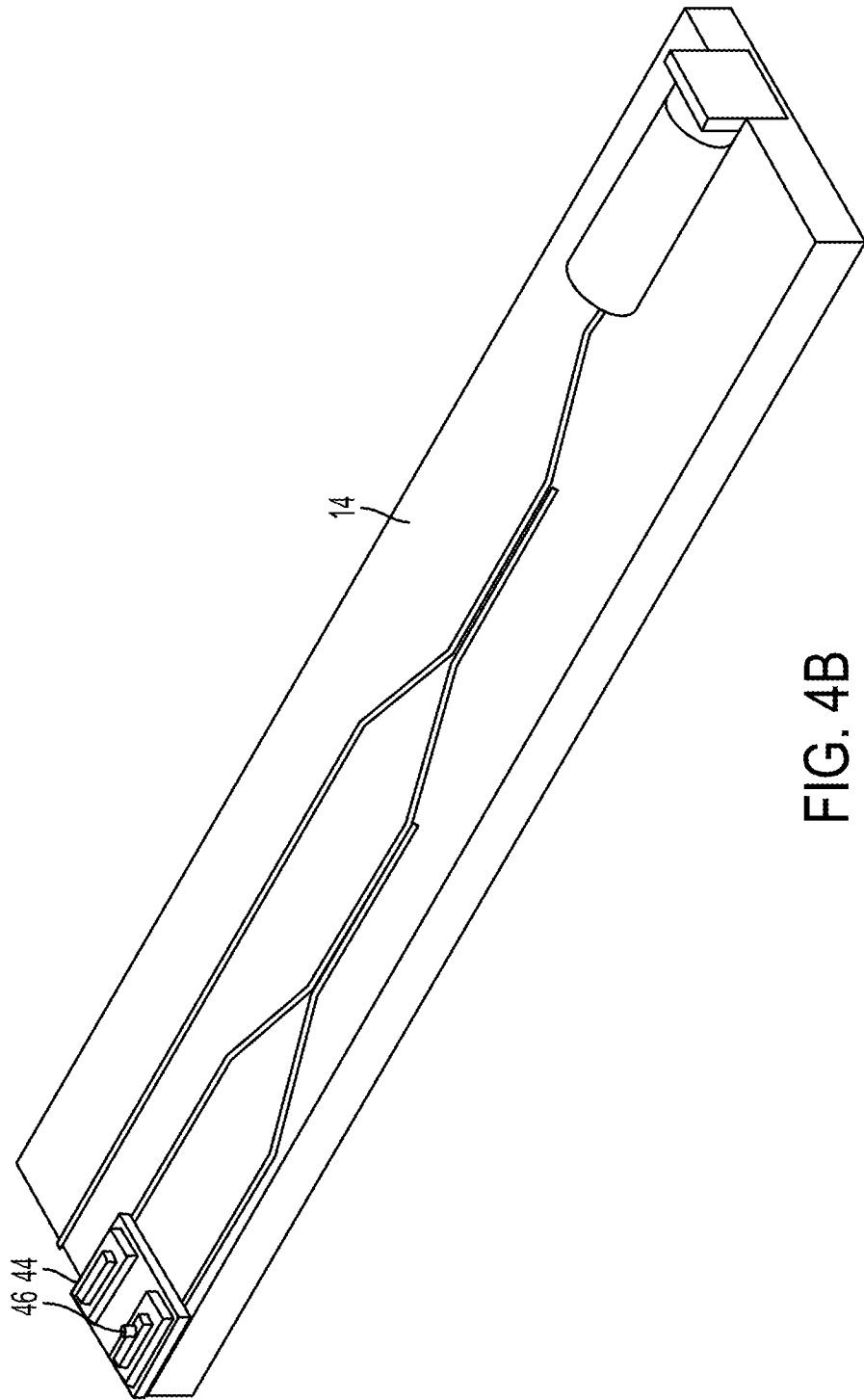

FIG. 4B

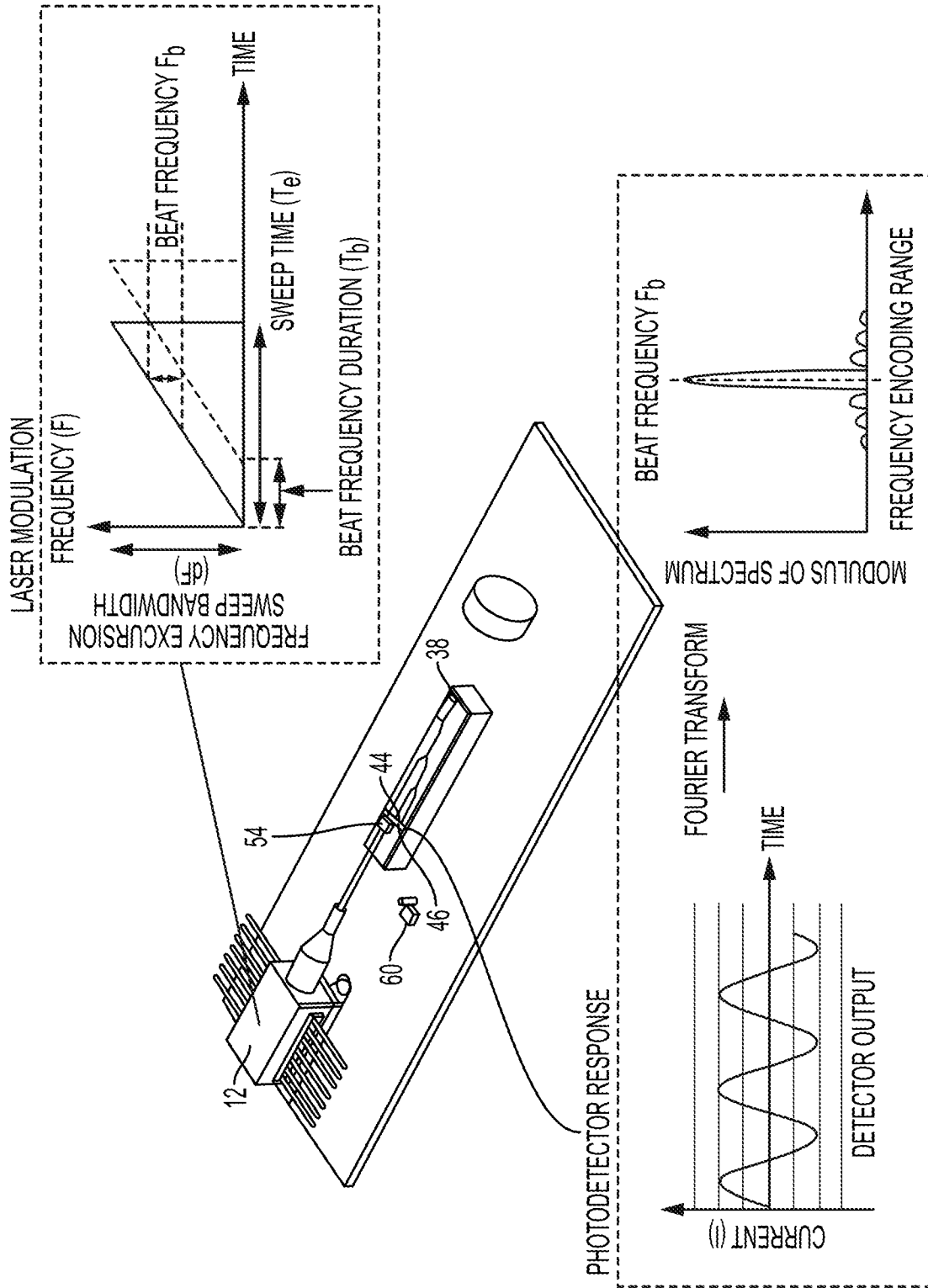

FIG. 5

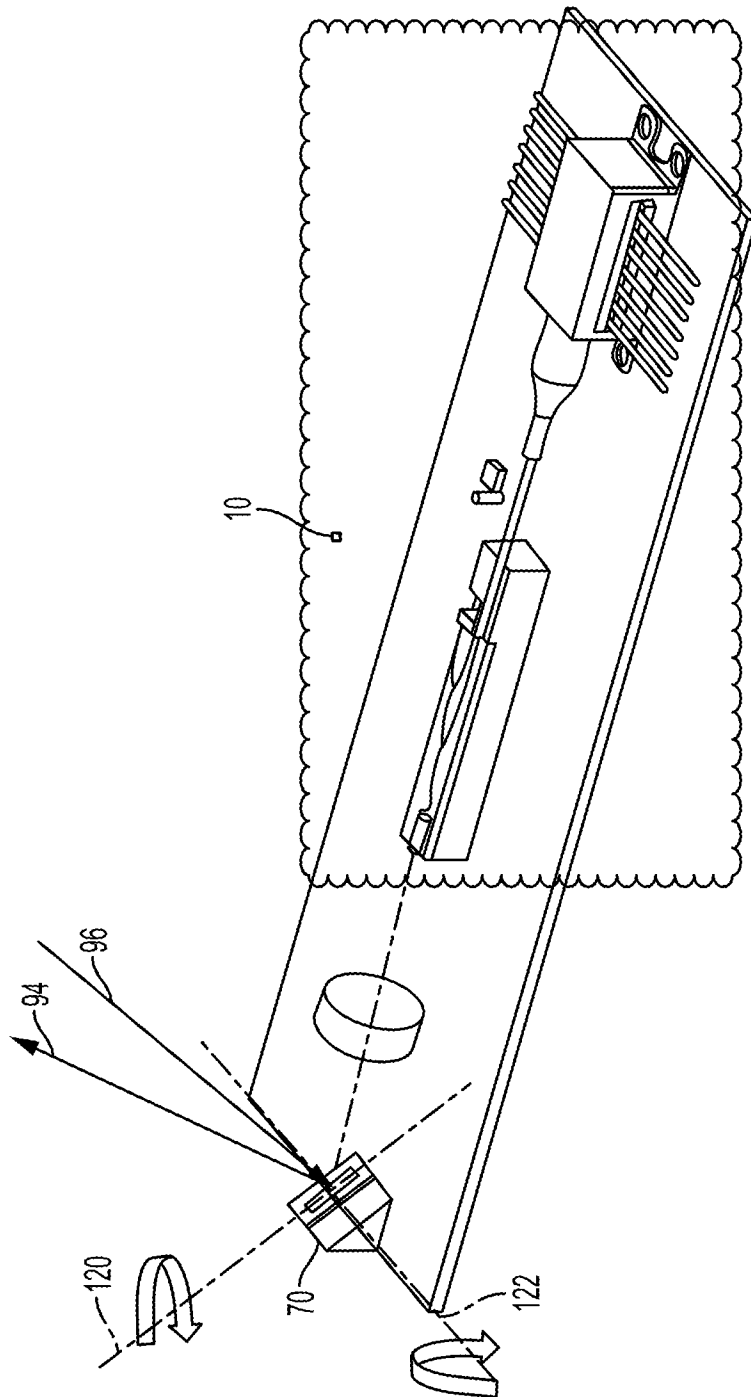

FIG. 7A

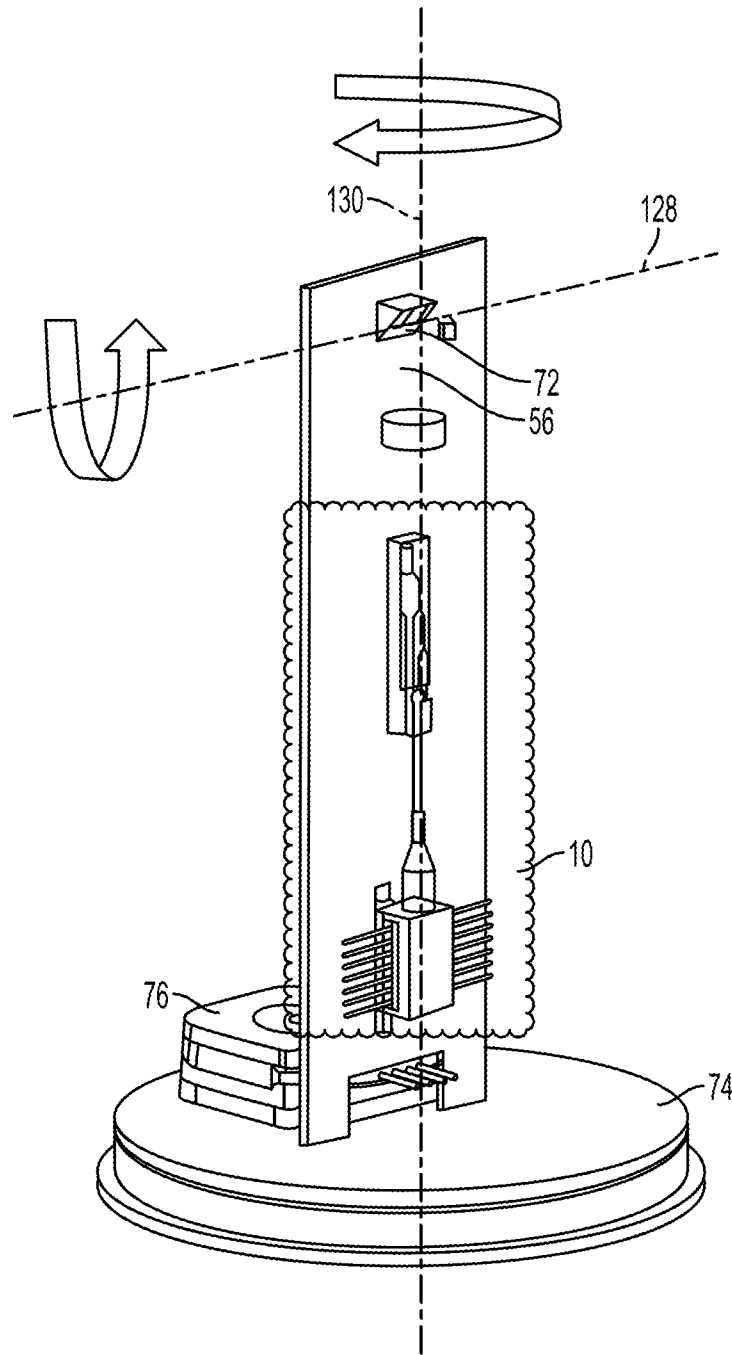

FIG. 7B

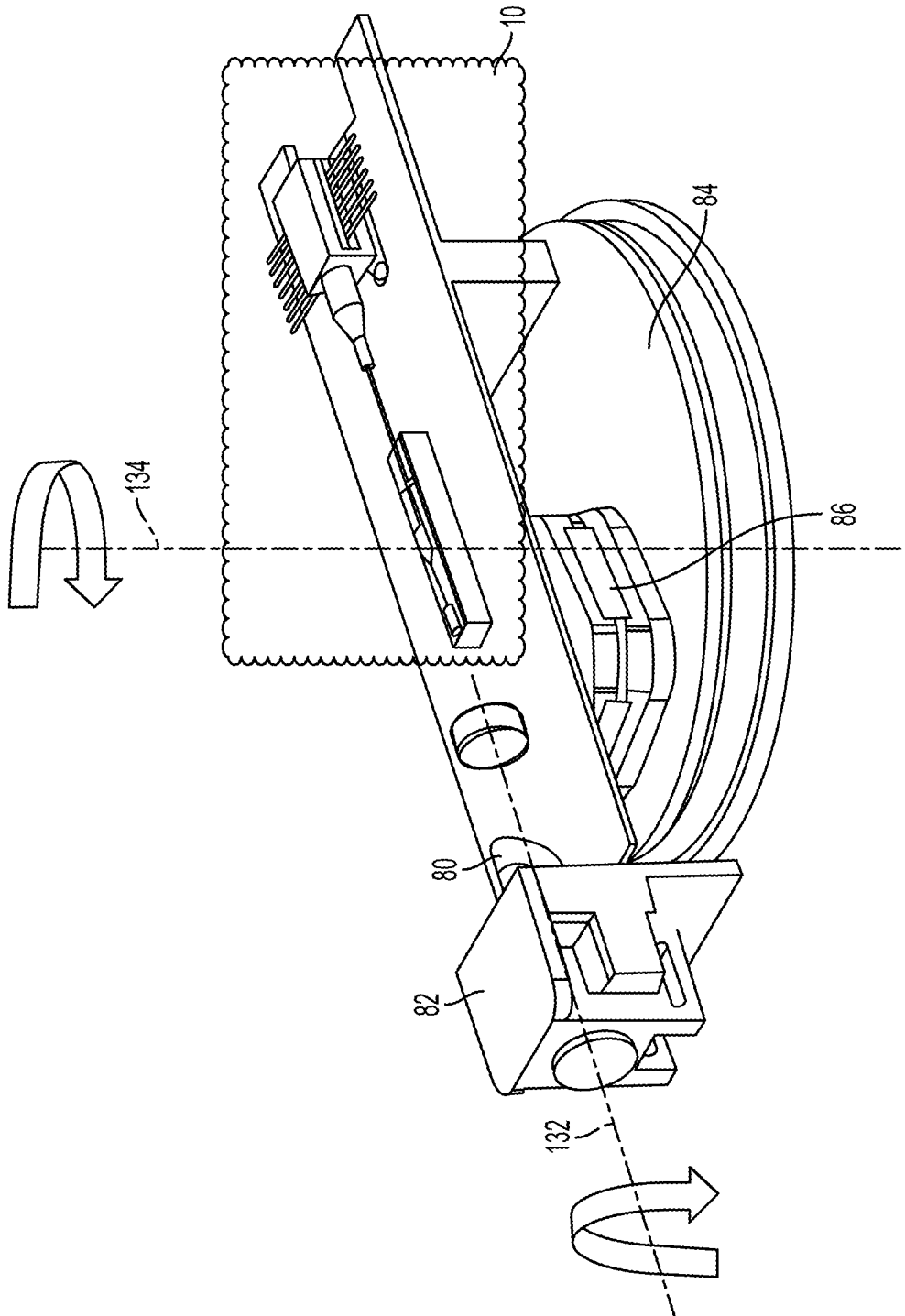

FIG. 8

INTERNATIONAL SEARCH REPORT

International application No.
PCT/US2018/040981

A. CLASSIFICATION OF SUBJECT MATTER
IPC(8) - G01B 9/02; G01C 3/08; G01J 9/00; G02B 6/00; H01L 31/00 (2018.01)
CPC - G01B 9/02; G01J 7/00; G01J 9/00; H01L 31/02024 (2018.08)

According to International Patent Classification (IPC) or to both national classification and IPC

B. FIELDS SEARCHED

Minimum documentation searched (classification system followed by classification symbols)
See Search History document

Documentation searched other than minimum documentation to the extent that such documents are included in the fields searched
USPC - 356/479; 356/482; 356/492; 356/497; 356/3.01; 356/4.09; 356/5.15; 356/5.09; 356/28.5 (keyword delimited)

Electronic data base consulted during the international search (name of data base and, where practicable, search terms used)
See Search History document

C. DOCUMENTS CONSIDERED TO BE RELEVANT

Category*	Citation of document, with indication, where appropriate, of the relevant passages	Relevant to claim No.
A	US 2012/0316830 A1 (EYAL) 13 December 2012 (13.12.2012) entire document	1-19
A	US 2011/0205523 A1 (REZK et al) 25 August 2011 (25.08.2011) entire document	1-19
A	US 4,830,486 A (GOODWIN) 16 May 1989 (16.05.1989) entire document	1-19
A	US 2009/0180099 A1 (KUROKAWA) 16 July 2009 (16.07.2009) entire document	1-19
A	US 2006/0182383 A1 (SLOTWINSKI) 17 August 2006 (17.08.2006) entire document	1-19

Further documents are listed in the continuation of Box C. See patent family annex.

* Special categories of cited documents:

"A" document defining the general state of the art which is not considered to be of particular relevance	"T" later document published after the international filing date or priority date and not in conflict with the application but cited to understand the principle or theory underlying the invention
"E" earlier application or patent but published on or after the international filing date	"X" document of particular relevance; the claimed invention cannot be considered novel or cannot be considered to involve an inventive step when the document is taken alone
"L" document which may throw doubts on priority claim(s) or which is cited to establish the publication date of another citation or other special reason (as specified)	"Y" document of particular relevance; the claimed invention cannot be considered to involve an inventive step when the document is combined with one or more other such documents, such combination being obvious to a person skilled in the art
"O" document referring to an oral disclosure, use, exhibition or other means	"&" document member of the same patent family
"P" document published prior to the international filing date but later than the priority date claimed	

Date of the actual completion of the international search 31 August 2018	Date of mailing of the international search report 13 SEP 2018
---	--

Name and mailing address of the ISA/US Mail Stop PCT, Attn: ISA/US, Commissioner for Patents P.O. Box 1450, Alexandria, VA 22313-1450 Facsimile No. 571-273-8300	Authorized officer Blaine R. Copenheaver PCT Helpdesk: 571-272-4300 PCT OSP: 571-272-7774
---	--