



(11) **EP 1 502 718 B1**

(12) **EUROPEAN PATENT SPECIFICATION**

(45) Date of publication and mention of the grant of the patent:  
**08.08.2007 Bulletin 2007/32**

(51) Int Cl.:  
**B27B 17/02<sup>(2006.01)</sup> B27B 17/00<sup>(2006.01)</sup>**

(21) Application number: **04102989.3**

(22) Date of filing: **28.06.2004**

(54) **Device for cutting branches and the like**

Vorrichtung zum Schneiden von Ästen und dergleichen

Dispositif pour couper des branches et analogues

(84) Designated Contracting States:  
**AT BE BG CH CY CZ DE DK EE ES FI FR GB GR HU IE IT LI LU MC NL PL PT RO SE SI SK TR**

(30) Priority: **30.07.2003 IT RM20030374**

(43) Date of publication of application:  
**02.02.2005 Bulletin 2005/05**

(73) Proprietor: **Cecchi, Remo Francesco**  
**71100 Foggia (IT)**

(72) Inventor: **Cecchi, Remo Francesco**  
**71100 Foggia (IT)**

(74) Representative: **Papa, Elisabetta et al**  
**Società Italiana Brevetti S.p.A**  
**Piazza di Pietra, 39**  
**00186 Roma (IT)**

(56) References cited:  
**EP-A- 0 062 188 EP-A- 1 031 395**  
**DE-U- 9 116 053 US-A- 1 825 164**  
**US-A- 2 572 405 US-A- 4 513 799**  
**US-A- 4 558 518 US-A- 4 654 972**  
**US-A- 4 760 646 US-A- 5 685 080**  
**US-A- 5 826 343**

**EP 1 502 718 B1**

Note: Within nine months from the publication of the mention of the grant of the European patent, any person may give notice to the European Patent Office of opposition to the European patent granted. Notice of opposition shall be filed in a written reasoned statement. It shall not be deemed to have been filed until the opposition fee has been paid. (Art. 99(1) European Patent Convention).

## Description

**[0001]** The present invention relates to a device for cutting branches and the like according to the preamble of claim 1. Such a device is known from US 4654972.

**[0002]** Devices for cutting branches and the like — often used for pruning — based on a chain-type annular cutting device are known in the art. Such devices comprise a track for guiding the cutting chain, said track typically having an ellipsoidal development, and a motor for producing a translatory motion of the chain itself along said track. Devices for cutting branches comprising a resting means resting on the piece to be cut are known from US 2572405.

**[0003]** Such cutting devices of the known art entail several drawbacks. The main drawback lies in vibrations and side shifting of the cutting device and difficulties of descent of the cutting chain into the cut.

**[0004]** Such a problem is solved by a device for cutting according to claim 1.

**[0005]** Preferred features of the present invention are present in the dependent claims.

**[0006]** Other features and operation steps of the present invention will be made apparent in the following detailed description of some embodiments thereof, given by way of a non-limiting example. Reference will be made to the figures of the annexed drawings, wherein: Figures 1-6 show embodiments not according to the invention.

Figure 1 shows an exploded view of a first embodiment of the device for cutting not according to the invention;

Figure 2 shows a perspective view of the device of Figure 1 in an assembled condition thereof;

Figure 3 shows a perspective view of a cutting kit comprising the device of Figure 1;

Figure 4 shows an exploded view of a detail of the device of Figure 1;

Figure 5 shows a perspective view of the detail of Figure 4;

Figure 6 shows a front view of the detail of Figure 4; and

Figure 7 shows a perspective view of another embodiment of the device for cutting according to the present invention.

**[0007]** Initially referring to Figures 1 and 2, a device for cutting branches and the like not according to the invention is generally indicated by 1.

**[0008]** In the present embodiment, the device 1 is an electric saw for the cutting of trees and the like.

**[0009]** The device 1 comprises a substantially flexible elongate cutting tool 2, having an annular development, which in the present embodiment is a conventional cutting chain.

**[0010]** Moreover, as it is better visible in Figures 4 to 6, the device 1 comprises a guide 3 shaped according to closed-path, cooperating with the chain 2 in order to

guide the cutting motion of the latter. The sense of the cutting motion of the chain 2 onto the guide 3 is indicated by arrows in Figure 6.

**[0011]** Always referring to Figures 4 to 6, in the present embodiment the guide 3 is an annular track, it also indicated by 3, developing along an elongate path and onto which the chain 2 extends. The track 3 is obtained at a peripheral edge 4 of a substantially flat guide body 5.

**[0012]** The track 3 has, at a bottom portion thereof, a recess 6 having a substantially loop-shaped contour, and in particular a substantially sinuous contour, having rounded corners.

**[0013]** The device 1 also comprises means 12, schematically depicted in Figure 1, for tensioning the chain 2 onto the track 3. Said means 12 is of a conventional type, and therefore will not be described in further detail.

**[0014]** Always referring to Figures 4 to 6, in correspondence of the track 3 the device 1 comprises means for dragging the chain 2, said means being housed within the guide body 5. In the present embodiment the means for dragging is in form of a first and a second sprocket, 7 and 8, respectively, each mounted on a respective bearing, e.g. a needle bearing.

**[0015]** In particular, the first sprocket 7 is arranged at a rear mouth of the recess 6, and precisely downstream of the latter with respect to the sense of the cutting motion of the chain 2 onto the track 3. Such an arrangement fosters an effective dragging of the chain 2, as it will be detailed hereinafter.

**[0016]** The second sprocket 8 is instead arranged at the foremost portion of the guide body 5.

**[0017]** The mounting on bearings of the sprockets 7 and 8 improves the dragging of the chain 2.

**[0018]** Further referring to Figures 1 and 2, the device 1 further comprises means for driving the chain 2, apt to slide the latter along the track 3, so as to give it a substantially translatory cutting motion.

**[0019]** In the present embodiment, the means for driving comprises an electric motor 9 that drives the chain 2 by interposition of conventional transmission means.

**[0020]** The motor 9 is powered by means of a battery, e.g. of a rechargeable type. The latter may easily be housed within a bag or pouch M carried or worn-on by the operator, as it is shown in Figure 3.

**[0021]** The motor 9 can be operated by means of a pushbutton or of an equivalent conventional system.

**[0022]** Of course, in an alternative embodiment the device could provide powering means different from that of the hereto-considered embodiment, e.g., an explosion engine. In fact, the former is more suitable in case the device of the invention consists of an electric saw or the like.

**[0023]** The device 1 also comprises a protecting cover 11 for covering the chain 2 when the device itself is not in operation; for simplicity's sake, said protection has been depicted solely in Figure 2.

**[0024]** In the present embodiment, the cover 11 consists of a sleeve opened lengthwise to receive the chain

2. Such a sleeve 11 is rotatably connected, and in particular hinged, onto the chassis of the device 1. Thus, it does not require a separate carrying and can easily be inserted on and taken out of the chain 2.

**[0025]** Moreover, the device 1 comprises a system for lubricating the chain 2 and a side means 13 resting on the piece to be cut, commonly called 'lug', of a conventional type and therefore not described in further detail.

**[0026]** The operation modes of the device 1 will hereinafter be illustrated with reference to all of the hereto-introduced figures.

**[0027]** When the operator operates the motor 9, the chain 2 is induced to slide onto the track 3, following an annular path about the latter.

**[0028]** In operation, the cutting of the piece is performed by an effective portion 20 of the chain 2 (enclosed within a dashed line in Figure 2) into contact with the piece itself. Such effective portion 20 extends at the recess 6 of the track 3, and therefore it is not into contact with the latter. In particular, as it is shown in Figure 6, in operation the effective portion 20 is substantially spaced apart from said track 3, exhibiting a maximal distance therefrom that is indicated by a reference height 203.

**[0029]** It will be understood that the fact that the effective portion 20 of the chain 2 is not into contact with the guide 3 does not penalize the efficiency and the effectiveness of the cutting, also by virtue of the arrangement of the dragging sprocket 7 immediately downstream of the recess 6. In particular, the cutting action could determine a slight bending of the effective portion 20 of the chain toward the track 3, without however determining, by virtue of said substantial distance 203, a contact between the two components. On the other hand, such bending of the portion 20 of the chain toward the wall of the recess 6 induces a moving away from the track 3 of a portion 21 of the chain opposite to the effective portion 20. Evidently, this further reduces the overall friction between slideway 3 and chain 2.

**[0030]** Referring now to Figure 7, according to the invention, the device for cutting comprises a side means 130 resting on the piece to be cut, which is different from the side means 13 of the first embodiment described with reference to the preceding figures.

**[0031]** In particular, the means 130 comprises a substantially vertical smooth chute-like edge 132 and a sprocket 131 arranged therebelow. According to the invention, the sprocket 131 rotates idle, e.g. above a needle bearing, and it is equipped with teeth apt to engage the piece to be cut, and in particular apt to break into the branch bark. The idle sprocket 131, by inserting the rotating teeth in the branch bark, annuls vibrations and side shifting of the cutting device, moreover easing the descent of the cutting chain into the cut jointly with the smooth bank 132 completing the detachment of the branch.

**[0032]** The smooth edge 132 may also be replaced by plural idle sprockets aligned thereamong.

**[0033]** Moreover, the sprocket or sprockets 131 may

be replaced by any other suitable rotating element.

**[0034]** Lastly, it will be understood that a kit comprising the device 1, the means 9 for driving, the battery and the bag or pouch M schematically shown in Figure 3 may be provided.

**[0035]** The present invention has hereto been described with reference to a preferred embodiment thereof. It is understood that there could be other embodiments falling within the scope of the claims set forth hereinafter.

## Claims

1. A device (1) for cutting branches and the like, comprising:

- a substantially flexible elongate cutting tool (2);
- a guide (3) shaped according to a closed-path, onto which said cutting tool (2) extends; and
- driving means (9) for driving said cutting tool (2), apt to slide the latter onto said guide (3) so as to provide it with a cutting motion,

wherein, in operation, an effective portion (20) of said tool (2) is in contact with the piece to be cut in order to perform the cutting,

wherein said guide (3) has, at said effective tool portion (20), a recess (6), the overall arrangement being such that at said recess (6) said guide (3) is not in contact with said effective portion (20) of the cutting tool (2)

**characterised in that** it further comprises a resting means (130) resting on the piece to be cut said resting means in its turn comprising an idle rotating element (131) equipped with teeth apt to engage the piece to be cut.

2. The device (1) according to claim 1, wherein the overall arrangement is such that at said recess (6) said guide (3) is substantially spaced apart from said effective portion (20) of the cutting tool (2).

3. The device (1) according to claim 1 or 2, wherein said cutting tool is an annular cutting chain (2).

4. The device (1) according to any one of the preceding claims, wherein said recess (6) of said guide (3) has a substantially loop-shaped contour.

5. The device (1) according to the preceding claim, wherein said recess (6) has a substantially sinuous contour, having rounded corners.

6. The device (1) according to any one of the preceding claims, wherein said guide comprises a track (3).

7. The device (1) according to any one of the preceding claims, comprising a shaped body (5) the peripheral

- edge of which implements said guide (3).
8. The device (1) according to any one of the preceding claims, comprising means (7, 8) for dragging said cutting tool (2), arranged at said guide (3). 5
9. The device (1) according to the preceding claim, wherein said means for dragging comprises a dragging element (7, 8) mounted onto a respective bearing. 10
10. The device (1) according to claim 8 or 9, wherein said means for dragging comprises a dragging element (7) arranged at a mouth of said recess (6). 15
11. The device (1) according to any one of claims 8 to 10, wherein said means for dragging comprises a dragging element (7) arranged downstream of said recess (6) with respect to the sense of the cutting motion of said tool (2) onto said guide (3). 20
12. The device (1) according to any one of claims 8 to 11, wherein said means for dragging comprises at least one guide sprocket (7, 8). 25
13. The device (1) according to any one of the preceding claims, wherein said means for driving comprises an electric motor (9).
14. The device (1) according to any one of the claims 1 to 12, wherein said means (9) for driving comprises an explosion engine. 30
15. The device (1) according to any one of the preceding claims, comprising a protecting cover (11) for covering said cutting tool (2). 35
16. The device (1) according to the preceding claim, wherein said protecting cover (11) is rotatably connected to the chassis of the device itself. 40
17. The device (1) according to claim 15 or 16, wherein said protecting cover comprises a sleeve element (11) lengthwise opened to receive said cutting tool (2). 45
18. The device (1) according to any of the preceding claims, wherein said resting means (130) comprises a plurality of rotating elements (131), each equipped with teeth apt to engage the piece to be cut. 50
19. The device (1) according to the preceding claim, wherein the rotating elements (131) of said plurality are arranged aligned thereamong. 55
20. A cutting kit for branches and the like, comprising a device for cutting (1) according to any one of the

preceding claims, a battery for powering said means (9) for driving said device (1) and a bag or pouch (M) for housing said battery.

### Patentansprüche

1. Vorrichtung (1) zum Schneiden von Ästen und dgl., mit:
- einem im Wesentlichen flexiblen, langgestreckten Schneidwerkzeug (2);
  - einer Führung (3), die zu einem geschlossenen Weg geformt ist und auf der sich das Schneidwerkzeug (2) erstreckt; und
  - einer Antriebseinrichtung (9) zum Antreiben des Schneidwerkzeuges (2), die in der Lage ist, letzteres auf der Führung (3) zu verschieben, um es so in eine Schneidbewegung zu versetzen,
- wobei im Betrieb ein wirksamer Teil (20) des Werkzeuges (2) mit dem zu schneidenden Teil in Kontakt ist, um den Schneidvorgang auszuführen, wobei die Führung (3) in dem wirksamen Werkzeugteil (20) eine Ausnehmung (6) hat und wobei die Gesamtanordnung so getroffen ist, dass in der Ausnehmung (6) die Führung (3) mit dem wirksamen Teil (20) des Schneidwerkzeuges (2) nicht in Kontakt ist, **dadurch gekennzeichnet, dass** sie weiter eine Auflageeinrichtung (130) aufweist, die sich auf das zu schneidende Teil auflegt, und dass die Auflageeinrichtung ihrerseits ein leer laufendes Drehelement (131) aufweist, das mit Zähnen ausgerüstet ist, die dafür ausgebildet sind, das zu schneidende Teil zu erfassen.
2. Vorrichtung (1) nach Anspruch 1, wobei die Gesamtanordnung so getroffen ist, dass in der Ausnehmung (6) die Führung (3) von dem wirksamen Teil (20) des Schneidwerkzeuges (2) wesentlich beabstandet ist.
3. Vorrichtung (1) nach Anspruch 1 oder 2, wobei das Schneidwerkzeug eine ringförmige Schneidkette (2) ist.
4. Vorrichtung (1) nach einem der vorhergehenden Ansprüche, wobei die Ausnehmung (6) der Führung (3) eine im Wesentlichen schleifenförmige Kontur hat.
5. Vorrichtung (1) nach dem vorhergehenden Anspruch, wobei die Ausnehmung (6) eine im Wesentlichen sinusförmige Kontur mit abgerundeten Ecken hat.
6. Vorrichtung (1) nach einem der vorhergehenden Ansprüche, wobei die Führung eine Führungsbahn (3) umfasst.

7. Vorrichtung (1) nach einem der vorhergehenden Ansprüche, mit einem geformten Körper (5), dessen Umfangsrand die Führung (3) bildet.
8. Vorrichtung (1) nach einem der vorhergehenden Ansprüche, mit einer Einrichtung (7, 8) zum Schleppen des Schneidwerkzeuges (2), die an der Führung (3) angeordnet ist.
9. Vorrichtung (1) nach dem vorhergehenden Anspruch, wobei die Schleppeinrichtung ein Schleppelement (7, 8) aufweist, das auf einem Lager angebracht ist.
10. Vorrichtung (1) nach Anspruch 8 oder 9, wobei die Schleppeinrichtung ein Schleppelement (7) aufweist, das an einer Mündung der Ausnehmung (6) angeordnet ist.
11. Vorrichtung (1) nach einem der Ansprüche 8 bis 10, wobei die Schleppeinrichtung ein Schleppelement (7) aufweist, das in Bezug auf die Richtung der Schneidbewegung des Werkzeuges (2) auf der Führung (3) stromabwärts der Ausnehmung (6) angeordnet ist.
12. Vorrichtung (1) nach einem der Ansprüche 8 bis 11, wobei die Schleppeinrichtung wenigstens ein Führungskettenrad (7, 8) aufweist.
13. Vorrichtung (1) nach einem der vorhergehenden Ansprüche, wobei die Antriebseinrichtung einen Elektromotor (9) aufweist.
14. Vorrichtung (1) nach einem der Ansprüche 1 bis 12, wobei die Antriebseinrichtung (9) einen Verbrennungsmotor aufweist.
15. Vorrichtung (1) nach einem der vorhergehenden Ansprüche, mit einem Schutzdeckel (11) zum Abdecken des Schneidwerkzeuges (2).
16. Vorrichtung (1) nach dem vorhergehenden Anspruch, wobei der Schutzdeckel (11) mit dem Rahmen der Vorrichtung selbst drehbar verbunden ist.
17. Vorrichtung (1) nach Anspruch 15 oder 16, wobei der Schutzdeckel ein Hülsenelement (11) aufweist, das in Längsrichtung geöffnet ist, um das Schneidwerkzeug (2) aufzunehmen.
18. Vorrichtung (1) nach einem der vorhergehenden Ansprüche, wobei die Auflageeinrichtung (130) mehrere Drehelemente (131) aufweist, die jeweils mit Zähnen ausgerüstet sind, welche dafür ausgebildet sind, das zu schneidende Teil zu erfassen.
19. Vorrichtung (1) nach dem vorhergehenden Anspruch, wobei die mehreren Drehelemente (131) gegenseitig in einer Linie ausgerichtet angeordnet sind.
20. Schneidbausatz für Äste und dgl., mit einer Schneidvorrichtung (1) nach einem der vorhergehenden Ansprüche, mit einer Batterie zur Stromversorgung der Antriebseinrichtung (9) der Vorrichtung (1) und mit einer Tasche oder einem Beutel (M) zum Aufnehmen der Batterie.

### Revendications

1. Dispositif (1) destiné à couper les branches et analogues, comprenant :
- un outil de coupe oblong sensiblement souple (2) ;
  - un guidage (3) formant un circuit fermé sur lequel s'étend ledit outil de coupe (2) ; et
  - des moyens de commande (9) pour entraîner ledit outil de coupe (2) apte à faire coulisser ce dernier sur ledit guidage (3), de façon à lui impartir un mouvement de coupe,
- dans lequel, dans le fonctionnement, une partie efficace (20) dudit outil (2) est en contact avec la pièce à couper afin d'effectuer la coupe,
- dans lequel ledit guidage (3) présente, sur ladite portion d'outil efficace (20), un évidement (6), l'agencement global étant tel qu'au niveau dudit évidement (6), ledit guidage (3) n'est pas en contact avec ladite partie efficace (20) de l'outil de coupe (2),
- caractérisé en ce qu'il** comprend, de plus, un moyen d'appui (130) reposant sur la pièce à découper, ledit moyen d'appui à son tour comprenant un élément de rotation libre (131) muni de dents capables de coopérer avec la pièce à découper.
2. Dispositif (1) selon la revendication 1, dans lequel l'agencement global est tel qu'au niveau dudit évidement (6), ledit guidage (3) est sensiblement espacé par rapport à ladite partie efficace (20) de l'outil de coupe (2).
3. Dispositif (1) selon la revendication 1 ou 2, dans lequel ledit outil de coupe est une chaîne de coupe annulaire (2).
4. Dispositif (1) selon l'une quelconque des revendications précédentes, dans lequel ledit évidement (6) dudit guidage (3) présente un contour sensiblement en forme de boucle.
5. Dispositif (1) selon la revendication précédente, dans lequel ledit évidement (6) présente un contour

- sensiblement sinueux avec des coins arrondis.
6. Dispositif (1) selon l'une quelconque des revendications précédentes, dans lequel ledit guidage comprend une voie de guidage (3). 5
7. Dispositif (1) selon l'une quelconque des revendications précédentes, comprenant un corps profilé (5) dont le bord périphérique constitue ledit guidage (3). 10
8. Dispositif (1) selon l'une quelconque des revendications précédentes, comprenant des moyens (7, 8) pour tirer ledit outil de coupe (2), disposé sur ledit guidage (3). 15
9. Dispositif (1) selon la revendication précédente, dans lequel lesdits moyens pour la traction comprennent un élément de traction (7, 8) monté sur un palier respectif. 20
10. Dispositif (1) selon la revendication 8 ou 9, dans lequel lesdits moyens pour la traction comprennent un élément de traction (7) disposé au niveau d'une embouchure dudit évidement (6). 25
11. Dispositif (1) selon l'une quelconque des revendications 8 à 10, dans lequel lesdits moyens pour la commande comprennent un élément de traction (7) disposé en aval dudit évidement (6) par rapport au sens du mouvement de coupe dudit outil (2) sur ledit guidage (3). 30
12. Dispositif (1) selon l'une quelconque des revendications 8 à 11, dans lequel lesdits moyens pour la traction comprennent au moins une roue dentée de guidage (7, 8). 35
13. Dispositif (1) selon l'une quelconque des revendications précédentes, dans lequel lesdits moyens pour la commande comprennent un moteur électrique (9). 40
14. Dispositif (1) selon l'une quelconque des revendications 1 à 12, dans lequel lesdits moyens (9) pour la commande comprennent un moteur à explosion. 45
15. Dispositif (1) selon l'une quelconque des revendications précédentes, comprenant un couvercle de protection (11) pour recouvrir ledit outil de coupe (2). 50
16. Dispositif (1) selon la revendication précédente, dans lequel ledit couvercle de protection (11) est relié de façon rotative au châssis du dispositif lui-même. 50
17. Dispositif (1) selon la revendication 15 ou 16, dans lequel ledit couvercle de protection comprend un élément d'enveloppe (11) ouvert longitudinalement pour recevoir ledit outil de coupe (2). 55
18. Dispositif (1) selon l'une quelconque des revendications précédentes, dans lequel lesdits moyens d'appui (130) comprennent une pluralité d'éléments rotatifs (131), chacun équipé de dents capables de s'engager sur la pièce à découper.
19. Dispositif (1) selon la revendication précédente, dans lequel les éléments de rotation (131) de ladite pluralité sont disposés en alignement.
20. Trousse de coupe pour branches et analogues, comprenant un dispositif pour la coupe (1) selon l'une quelconque des revendications précédentes, une batterie pour l'alimentation en puissance électrique desdits moyens (9) pour la commande du dispositif (1) et un sac ou étui (M) pour le logement de ladite batterie.

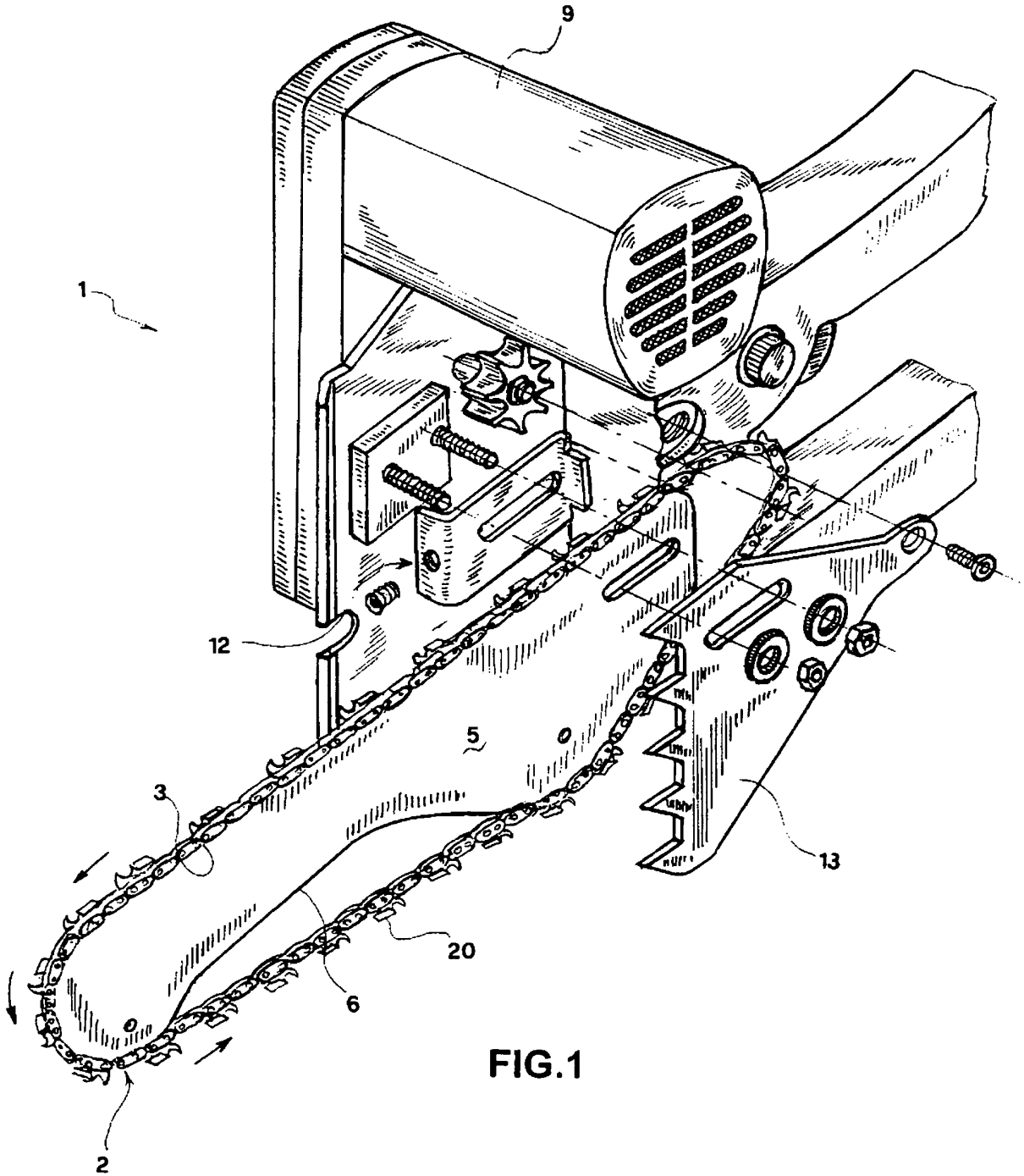

FIG.1

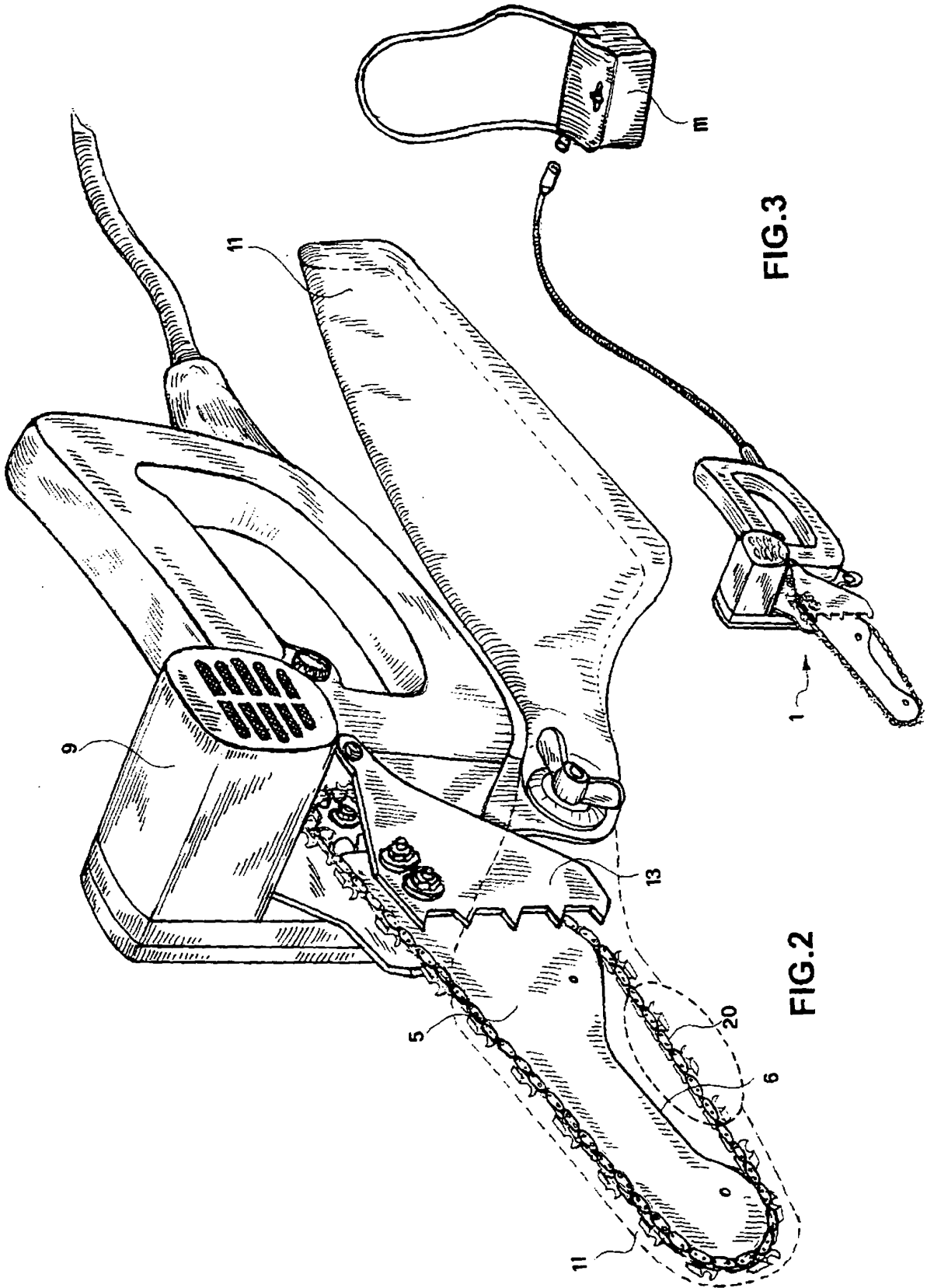

FIG.3

FIG.2

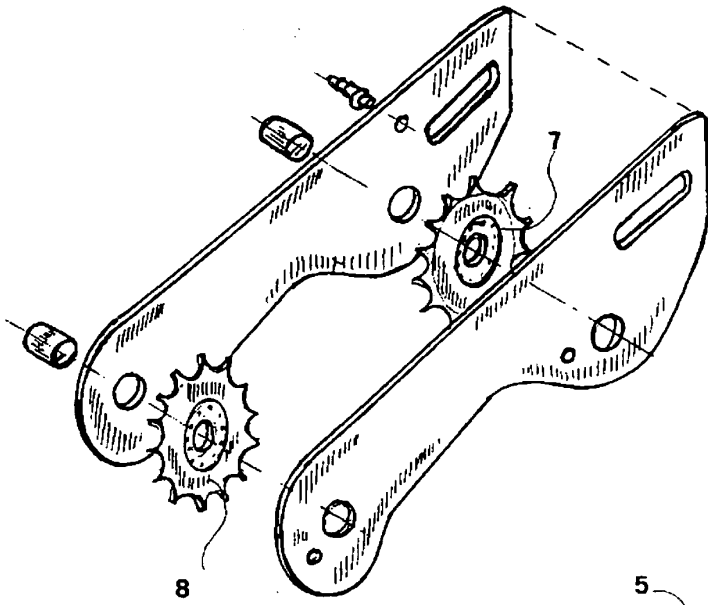

FIG. 4

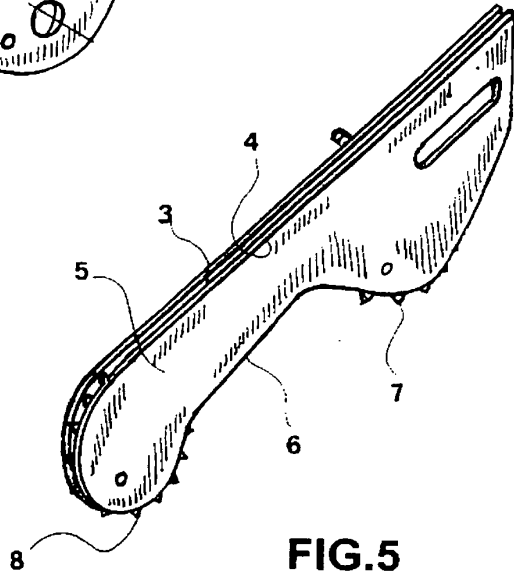

FIG. 5

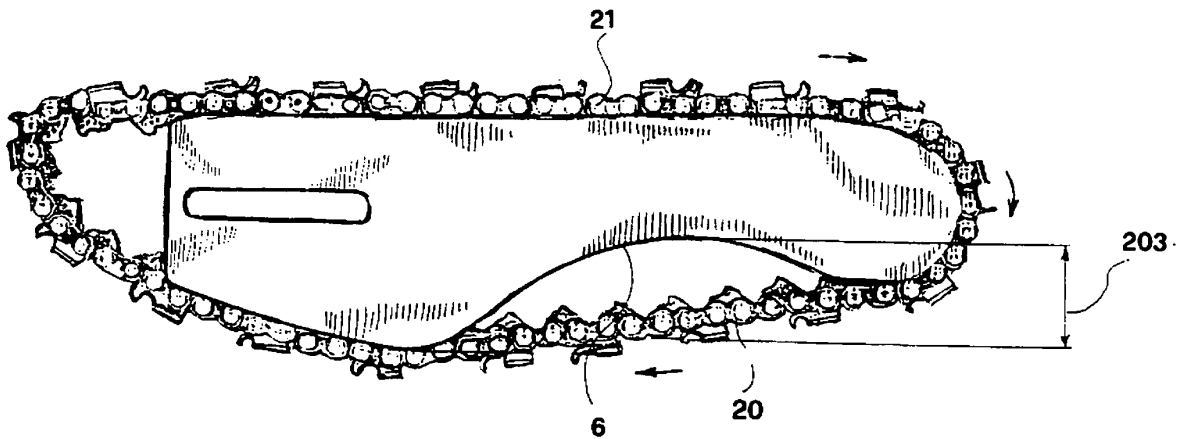

FIG. 6

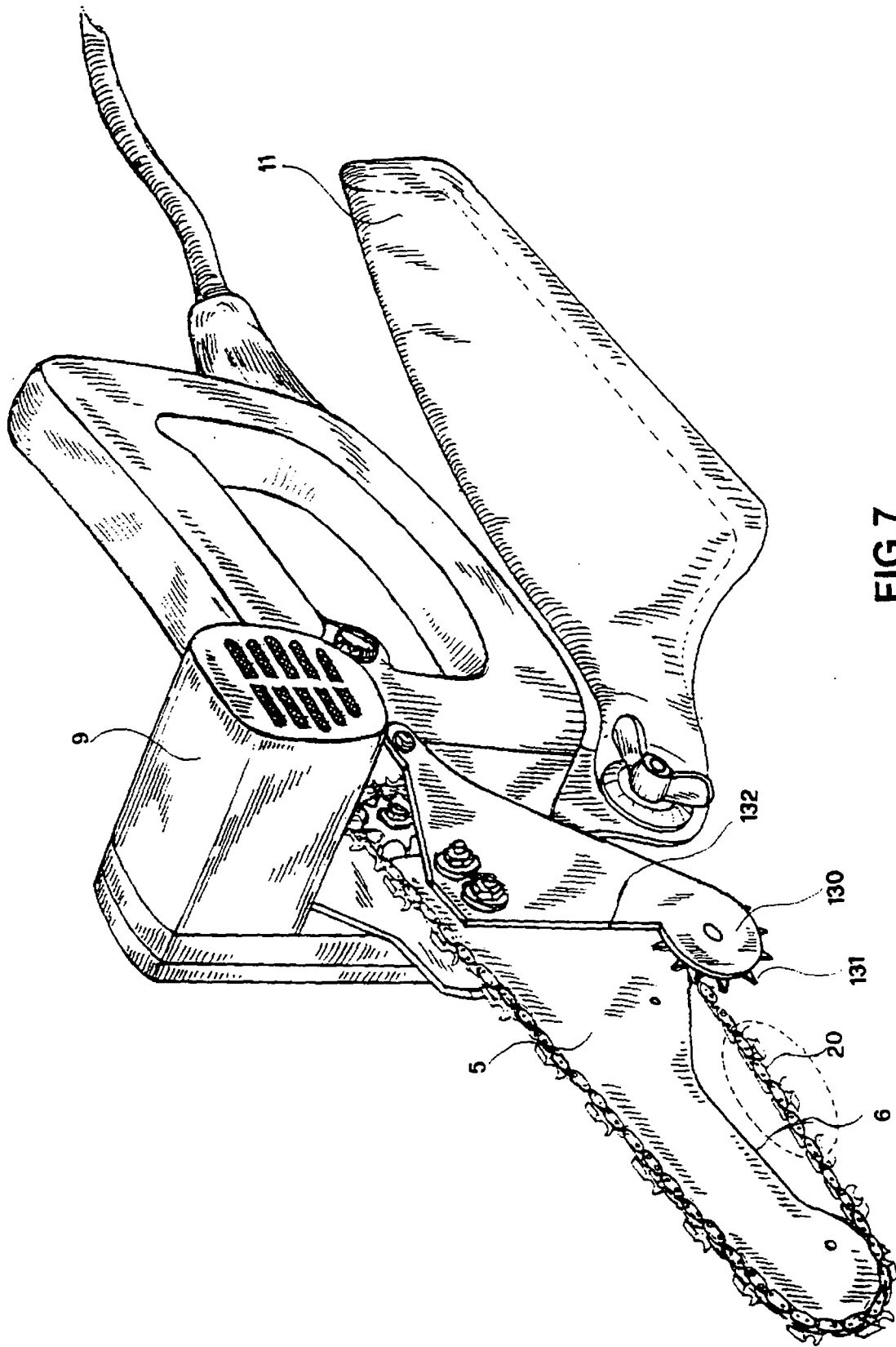

FIG.7

**REFERENCES CITED IN THE DESCRIPTION**

*This list of references cited by the applicant is for the reader's convenience only. It does not form part of the European patent document. Even though great care has been taken in compiling the references, errors or omissions cannot be excluded and the EPO disclaims all liability in this regard.*

**Patent documents cited in the description**

- US 4654972 A [0001]
- US 2572405 A [0002]