



(11) **EP 1 600 573 B1**

(12) **EUROPEAN PATENT SPECIFICATION**

(45) Date of publication and mention of the grant of the patent:  
**29.04.2009 Bulletin 2009/18**

(51) Int Cl.:  
**E04B 5/02** (2006.01) **E04C 3/294** (2006.01)  
**E04C 5/065** (2006.01) **B28B 23/02** (2006.01)  
**E04B 2/86** (2006.01)

(21) Application number: **05076214.5**

(22) Date of filing: **24.05.2005**

(54) **Prefabricated construction element**

Fertigteilbauelement

Elément de construction préfabriqué

(84) Designated Contracting States:  
**AT BE BG CH CY CZ DE DK EE ES FI FR GB GR HU IE IS IT LI LT LU MC NL PL PT RO SE SI SK TR**

(30) Priority: **25.05.2004 NL 1026256**

(43) Date of publication of application:  
**30.11.2005 Bulletin 2005/48**

(73) Proprietor: **Bartoli N.V.**  
**Willemstad, Curaçao (AN)**

(72) Inventor: **Bartels, Michael Jacobus Gerhardus**  
**7631 BC Ootmarsum (NL)**

(74) Representative: **Barendregt, Frank**  
**Exter Polak & Charlouis B.V.,**  
**P.O. Box 3241**  
**2280 GE Rijswijk (NL)**

(56) References cited:  
**DE-A- 1 609 571** **DE-A- 10 116 976**  
**DE-A1- 4 434 499** **DE-C- 812 464**  
**DE-U- 20 007 312** **DE-U1- 29 916 463**  
**FR-A- 2 373 651** **US-A- 4 261 150**

**EP 1 600 573 B1**

Note: Within nine months of the publication of the mention of the grant of the European patent in the European Patent Bulletin, any person may give notice to the European Patent Office of opposition to that patent, in accordance with the Implementing Regulations. Notice of opposition shall not be deemed to have been filed until the opposition fee has been paid. (Art. 99(1) European Patent Convention).

## Description

**[0001]** The present invention relates to a floor according to the preamble of claim 1. DE 4434499 A1 discloses such a floor.

**[0002]** Prefabricated construction elements comprising a first concrete slab are well known in the prior art. The prefabricated construction elements are used for floors and walls. Such prefabricated floor elements are concrete slabs which can form a span between two walls by laying the floor elements on or against a wall or another structure on at least two of their sides. Vertical placement of the construction elements enables them to be used as a wall. Structures of this type are used in the construction of houses as well as offices and commercial properties.

**[0003]** In order to form a floor, floor elements are laid in such a manner that their edges abut, following which a covering floor is fitted over the floor elements. The covering floor is intended for structural strength and finishing of the floor.

**[0004]** A drawback of a floor structure of this type is that it is no longer possible to arbitrarily install conduits in the floor after production of the floor elements. During production, a floor element may be provided with, for example, a central electrical junction box and cables leading to it can be incorporated in the covering floor later. In addition, cables with a relatively small height can be arranged in the covering floor, for, for example, floor connections for computer networks and the like, but the locations for such connections can only be determined before the covering floor is fitted. Once the covering floor has been fitted, the connections can no longer be moved.

**[0005]** However, in many buildings, there are also conduits with a large cross section, such as for example sewer conduits and air-conditioning conduits, running through various rooms. Such conduits are then arranged under the floor and a removable system ceiling is subsequently fitted under the conduits in order to hide the conduits from view, while ensuring that they are accessible in case modifications have to be made or malfunctions have to be rectified. Conduits with a small cross section can likewise be fitted under the floor, but above the system ceiling, in order to provide flexibility regarding the position of connections for a computer network or the like.

**[0006]** The known structure of a floor made from prefabricated floor elements and a lowered system ceiling requires additional work for attaching conduits to the floor elements and for attaching the ceiling underneath the latter. In addition, connecting cables have to be run down for connections, such as computer connections, in vertical cable ducts, for example. However, for sewer conduits, in many cases holes have to be made in the floor elements in order to connect, for example, a toilet bowl above the floor element to a sewer conduit under the floor element. This may cause undesirable noises on the storey beneath it.

**[0007]** Conduits are often arranged in walls in order to

hide them from view. To this end, special ducts are accommodated in the design of a building or grooves are provided in the walls in order to accommodate conduits therein and the grooves are subsequently concealed again, for example by plastering the wall.

**[0008]** It is an object of the present invention to provide a floor in which the conduits can easily be arranged in a floor or wall and in which, if desired, the conduits remain accessible in order to modify existing connections, to fit new connections or to rectify malfunctions.

**[0009]** The object mentioned above is achieved by means of a floor according to claim 1.

**[0010]** With a floor according to the present invention, which is used as a floor element, the side of the first concrete slab remote from the second concrete slab may serve as a ceiling and the side of the second concrete slab remote from the first concrete slab may serve as a floor. As the concrete slabs are placed at a distance from one another, there is a space between the two concrete slabs. This space can be used to accommodate conduits. The distance between the slabs can be chosen almost completely arbitrarily during production of the construction elements, for example depending on the conduits which have to (be able to) be accommodated therein.

**[0011]** The load-bearing structure has a load-bearing capacity which is such that the space between the slabs does not have to be filled with any other material in order to attain sufficient load-bearing capacity, both when used as a floor element and as a wall element. Therefore, the conduits can be accommodated in the space between the first and second concrete slab. Conduits can thus be moved, replaced, repaired or added at any time. It is also possible to fit floor or wall connections in arbitrary locations to the conduits placed in the floor or wall after the construction elements have been installed.

**[0012]** Preferably, the second length is smaller than the first length. The second width is smaller than the first width. If a number of floor elements are placed laterally next to one another in order to form a ceiling or a floor, with the first concrete slabs bearing on a wall or other supporting structure and laterally abutting, an opening remains between the adjacent second concrete slabs. This opening ensures that the space is easily accessible, even after the floor elements have been placed. Said opening is covered in a simple manner with a panel suitable for the purpose, so that an even floor and/or a continuous ceiling is created.

**[0013]** Of course, it is likewise possible to choose the second concrete slab to be larger than the first, an opening being created between the adjacent first concrete slabs after the floor element has been placed, so that the space between the concrete slabs is accessible from underneath. The floor element can then bear with a concrete slab on a supporting structure or the floor element can bear on the supporting structure via one or more edges of a concrete slab.

**[0014]** The load-bearing structure is advantageously made of metal and has an open structure in the direction

of the first and second length and/or in the direction of the first and second width. A strong open load-bearing structure can easily be produced using metal. Such an open structure of the load-bearing structure makes it possible to run conduits through the load-bearing structure. The more openings and the larger the openings in the load-bearing structure, the easier it is to arrange conduits in the space between the first and second concrete slabs along an arbitrary path.

**[0015]** Preferably, the load-bearing structure consists of a number of load-bearing elements, each load-bearing element comprising a first and a second metal beam and metal bars fitted in-between the latter, each pair of successive bars forming a triangle with one of the metal beams, and the first metal beam being disposed, at least partly, in the first concrete slab and the second metal beam being disposed, at least partly, in the second concrete slab.

**[0016]** A load-bearing element of this type is rigid and has a great load-bearing capacity. The metal is preferably steel and in particular reinforcing steel. Furthermore, the metal, in particular steel, is preferably tubular, which further increases the strength of the structure.

**[0017]** Preferably, a concrete layer is arranged on a surface formed by installing a number of concrete slabs of a number of construction elements as floor elements. The concrete layer ensures a diaphragm action, as a result of which the structure is strengthened further, sound insulation and/or thermal insulation.

**[0018]** If the conduits do not have to be accessible after having been fitted, or if a very heavy or a very strong floor is desired, the space between the first and second concrete slabs can at least partially be filled with heavy concrete or cellular concrete.

**[0019]** In order to further strengthen the floor, a reinforcement may be arranged in the concrete applied after the construction element has been placed. The reinforcement ensures an improved diaphragm action.

**[0020]** Furthermore, a floor according to the present invention comprises a covering panel which is clearly intended for covering the openings between the floor elements. The dimensions of the covering panels correspond to the dimensions of the opening between the first and second concrete slabs after the latter have been placed. In this case, a covering panel may be of a length equal to the opening between the concrete slabs or a smaller length, so that the entire length of the concrete slabs can be covered with a number of covering panels.

**[0021]** If the construction elements are being used as a floor, the covering panels have to be suitable to support a predetermined minimum weight. A covering panel of this type may be provided with connecting sockets which are installed during production, for example for a computer network connection, for air supply and/or discharge or for an electrical connection.

**[0022]** The present invention furthermore relates to a method for producing a floor element according to the present invention, comprising producing a load-bearing

element for a load-bearing structure, producing a first concrete slab in connection with said load-bearing structure and producing a second concrete slab in connection with said load-bearing structure, said load-bearing element comprising a first and a second metal beam and metal bars fitted in-between the latter, each pair of successive bars forming a triangle with one of the metal beams. The production of the load-bearing element comprises substantially simultaneously welding a bar to the first beam and to the second beam, which prevents the bars from becoming warped during welding.

**[0023]** Preferably, each bar is welded to each beam along two seams in order to provide a strong connection. Each bar is attached to a beam with its preferably oblique end side. If only one weld seam is used, a bar may bend or pivot about the weld seam and may even break away. By using two weld seams, preferably opposite one another viewed in the direction of the end side of the bar, the weld seams cannot act as a pivot and, in addition, a stronger connection is achieved. Simultaneous welding of the two seams prevents the bar from becoming warped during welding.

**[0024]** Simultaneous welding according to the above method is preferably carried out using a welding robot, which not only welds simultaneously, but also for an equal period and over an equal length of every weld seam. In this manner, identical and strong welded joints are produced which generate as little tension as possible in the bars.

**[0025]** The invention will be described in more detail below with reference to a non-limiting exemplary embodiment which is shown in the attached drawing and in which:

Fig. 1 shows a cross section of a construction element according to the present invention,

Fig. 2 shows a view of a load-bearing element of a load-bearing structure for a construction element according to the present invention,

Fig. 3 shows a cross section of a floor according to the present invention,

Fig. 4 shows a cross section of a wall and a floor supported by said wall, both comprising a construction element according to the present invention,

Fig. 5 shows a cross section of an embodiment of a floor element fitted to a wall element, and

Fig. 6 shows a floor according to the present invention, the space between the concrete slabs of the floor element being accessible from below.

**[0026]** Fig. 1 shows a construction element 2 which is constructed from a first concrete slab 4 and a second concrete slab 6. With the illustrated construction element 2, the second concrete slab 6 is of a smaller width than the first concrete slab 4. The length of the first concrete slab 4 and the length of the second concrete slab 6 may be equal or one of the two lengths may be smaller, depending on the use and the chosen design.

**[0027]** A steel load-bearing structure is disposed between the first and second concrete slabs 4, 6. The load-bearing structure comprises a first load-bearing element 8a and a second load-bearing element 8b. The two load-bearing elements 8a and 8b are at an angle with respect to one another for structural rigidity and strength.

**[0028]** A construction element 2 may also comprise more than two load-bearing elements, depending on the desired width of the construction element 2, a minimum weight to be supported, a span to be bridged and possible other aspects which depend on the individual case. Each construction element 2 can be designed for an individual case, based on a span to be bridged, a minimum weight to be supported and other criteria, such as conduits to be installed.

**[0029]** Fig. 2 shows a load-bearing element 8 with two beams 10a and 10b and bars 12 fitted in-between the latter. Each pair of successive bars 12 forms a triangle together with one of the beams 10a, 10b. The geometry of the triangle may be chosen on the basis of the desired height of the construction element and the desired strength. The beams 10a and 10b are disposed in the concrete slabs 4, 6.

**[0030]** Fig. 2 shows a construction element which has been installed as a floor element and rests on a wall 14. The load-bearing element 8 is incorporated into the concrete slab 6 which has been placed on a supporting body, such as the load-bearing wall 14. This concrete slab is further supported in at least one other location of the floor element. Preferably, the floor element is supported at locations where one or two bars 12 are connected to the beam 10b, as is shown in Fig. 2. In Fig. 2, the floor element is in fact supported at one end by the wall 14 and at the supporting location, a bar 12a is connected to the beam 10b. This prevents the beam 10b from bending under the load to be borne at the supporting location.

**[0031]** The configuration of the beams 10a, 10b and the bars 12 in the form of adjoining triangles shown in Fig. 2 has been chosen for structural strength and rigidity which are inherent to such triangular configurations, as is known in the field. However, other configurations are also possible, as long as the strength of the structure remains sufficient.

**[0032]** With the load-bearing element 8 shown in Fig. 2, the bars 12 have been welded to the beams 10. For a strong construction, each bar 12 has been welded to each beam at two spots or along two seams. When a bar 12 is welded in one spot or along one seam, the bar 12 may deform and thus make welding along the second seam or to the second beam difficult or impossible, and if it is still possible, undesirable stresses will occur in the load-bearing element 8. In order to prevent this problem, the bars are preferably welded simultaneously to the beam at the two spots or along the two seams. In this case it is advantageous if the welding is carried out by an automatic welding device, as such a device produces two (or more) substantially identical welds, as a result of which stresses in the respective materials are reduced further.

Deformations of the bars 12 are further reduced by producing the total of four welds on the two beams simultaneously, preferably using an automatic welding device. By means of this method, it is possible to produce straight and strong load-bearing elements, which enables the production of floor elements.

**[0033]** Fig. 3 shows an embodiment of a floor according to the present invention made up of construction elements 2, in which use is made of a load-bearing construction comprising three load-bearing elements 20a, 20b, 20c. The use of three load-bearing elements can result in a greater load-bearing capacity and/or greater rigidity of the construction element. As a result, it is possible to construct and use wider and/or longer concrete slabs 4, 6. It is also possible to use a load-bearing structure of this type in order to enable a floor to bear a greater load.

**[0034]** Fig. 3 shows a number of construction elements 2. The construction elements 2 are placed next to one another and form a continuous surface on the side of the concrete slabs 6. This continuous surface may, as illustrated, be located at the bottom and act as a ceiling, but may also be located on any other side, depending on the use.

**[0035]** After the construction elements 2 have been placed next to one another, a concrete layer 22 is disposed between the two concrete slabs 4, 6 on the concrete slabs 6. A reinforcement 24 is arranged in the concrete layer 22 above a joint between adjacent construction elements 2. The concrete layer 22 ensures a diaphragm action, as a result of which the entire structure is reinforced. Incidentally, depending on the use, the entire space between the concrete slabs 4, 6 may be filled with concrete, cellular concrete or another material, for example a sound- or vibration-dampening material and/or thermal insulation material.

**[0036]** Openings between the concrete slabs 4 are covered with a covering panel 26. The covering panel 26 can be made from any material, depending on the desired strength and use. The covering panels 26 and the concrete slabs 4 together form a surface, the covering panels, if desired, being removable in order to access the space between the concrete layer 22 and the concrete slabs 4.

**[0037]** There is a space between the concrete layer 22 on one side and the concrete slabs 4 and the covering panels 26 on the other side for installing electrical cables 29 and other conduits 30. If the covering panels 26 have been fitted so as to be removable and replaceable, the cables/conduits 29, 30 are easily accessible in case of malfunctions or new conduits and/or pipes can easily be installed in the gap. In Fig. 3, the electrical cables 29 are connected to an electrical junction box, which is arranged in a concrete slab 6.

**[0038]** Depending on the choice of the load-bearing structure, i.e. the configuration thereof, the materials used and the form of the section of the bars 12 and the beams 10, etc., the construction elements 2 can bridge

spans of up to 20 metres at least.

**[0039]** Fig. 4 illustrates a floor element 2 and a wall element 42. The floor element 2 comprises a first concrete slab 4 and a second concrete slab 6, the first concrete slab 4 being wider than the second concrete slab 6. As a result of the first concrete slab 4 protruding relative to the second concrete slab 6, the floor element 2 can easily be placed on a load-bearing structure.

**[0040]** In the embodiment shown in Fig. 4, the first concrete slab 4 rests on a first concrete slab 44 of a wall element 42. The second concrete slab 46 is higher than the first concrete slab 44, namely such that the end side of the second concrete slab 46 is level with the top of the first concrete slab 4 of the floor element 2.

**[0041]** It can clearly be seen from Fig. 4 that the space between the first and the second concrete slab 4, 6 in the floor element 2 is greater than that of the wall element 42. Furthermore, the concrete slabs 4, 6 of the floor element 2 are thicker than those of the wall element 42. Such a difference in dimensions is not required and only depends on the desired strength. All dimensions of the construction elements may be selected to be different, depending on function and desired strength and space and other parameters.

**[0042]** In addition to the beams 10, bars 12, concrete layer 22 and conduits 30 already shown in the previous figures, Fig. 4 shows a reinforcement 24 which also provides a connection between the concrete layer 22 and the first concrete slab 44 of the wall element 42. This results in a strong connection between the floor element 2 and the wall element 42. The conduits 30, which are arranged between the concrete slabs 4, 6 of the floor element 2, are connected to the conduits 30 in the wall element 42 by means of a coupling piece 31. However, a coupling piece 31 is not essential, but does simplify installation of the conduits 30.

**[0043]** The space between the concrete slabs 44, 46 of the wall element 42 may remain empty (except for the conduits 30 installed therein) or this space can be filled with any material, for example sound insulation, thermal insulation material, sand or concrete, depending on the desired properties of the wall.

**[0044]** Fig. 5 shows another connection between a wall and a floor element 2. In this embodiment, a first, relatively large concrete slab 6 rests on a wall element 42A, while a second, relatively small concrete slab 4 above it forms a floor. A filling material 22, for example concrete, is disposed in the first wall element 42A.

**[0045]** A second wall element 42B is placed in the first wall element 42A. The wall element 42B comprises two concrete slabs 44, 46, which in the position shown are vertically level. The second wall element 42B is likewise filled with a material 48. Preferably, this material 48 is the same as the filling material 22 with which the first wall element 42A is filled and the material 48 provides a connection to the filling material 22. Although this has not been shown, a reinforcement material may be arranged in the filling material 22, 48 in order to further reinforce

the connection.

**[0046]** Fig. 6 shows a further embodiment of a floor according to the present invention. The floor element comprises a first concrete slab 6 which forms a continuous floor surface with the adjacent floor elements. The floor element furthermore comprises two concrete slabs 4A and 4B which are each connected separately by means of a load-bearing structure with load-bearing elements 20 to the first concrete slab 4. The concrete slabs 4A and 4B form a ceiling for a storey running beneath the floor elements, covering panels 26 closing the ceiling surface. The covering panels 26 are removable so that conduits 30 are easily accessible. Connections for the conduits 30 can easily be installed in the covering panels 26, as well as for example an electrical junction box 28.

**[0047]** In order to provide a strong structure by forming a diaphragm which ensures diaphragm action, a cover layer 32 may be provided on the top of the floor element. In addition, a reinforcement may be arranged in the cover layer 32.

**[0048]** The construction elements are particularly suitable for use in commercial properties which require many cables/conduits, such as for example hospitals, where many electrical devices are often moved around and furthermore conduits for air treatment, oxygen and the like have to be accessible near each bed. Likewise, office environments where electrical appliances are being used in increasing numbers at each work station and more and more air treatment is being applied, space in the floors and/or the walls offers possibilities. A floor according to the present invention, for example, make the well-known cable ducts on the walls of offices redundant.

## 35 Claims

1. Floor, comprising prefabricated adjacent construction elements (2, 42), the prefabricated construction elements comprising:

- a first concrete slab (4, 44) of a first length and a first width;
- a second concrete slab (6, 46) of a second length and a second width;
- wherein the first concrete slab and the second concrete slab are placed at a distance from one another as well as substantially parallel with respect to one another, and are connected by a load-bearing structure for forming a space between the first concrete slab and the second concrete slab;
- wherein said second width is smaller than said first width, such that an opening remains between the adjacent second concrete slabs;
- wherein the adjacent first slabs are laterally abutting;
- a prefabricated panel (26) for covering the opening;

- **characterized in that** the outer surface of the prefabricated panel, together with the outer surface of the adjacent second slabs, forms an even floor and/or a continuous ceiling surface.
2. The floor according to claim 1, wherein the opening extends along the second length of the adjacent second concrete slabs.
3. The floor according to claim 1 or 2, wherein the panel extends along the second length of the adjacent second concrete slabs.
4. The floor of any of the previous claims, wherein the panel removably covers the opening.
5. The floor of any of the previous claims, wherein said second length is smaller than said first length.
6. The floor of any of the previous claims, wherein the load-bearing structure (8) has an open structure in the direction of the first length and the second length and/or in the direction of the first and second width.
7. The floor of any of the previous claims, wherein the space between the first concrete slab and the second concrete slab is accessible through the opening.
8. The floor of any of the previous claims, wherein the load-bearing structure comprises a number of load-bearing elements (8, 20), each load-bearing element (8) comprising a first and a second metal beam (10) and metal bars (12) fitted in-between the latter, each pair of successive bars (12) forming a triangle with one of the metal beams (10), and the first metal beam (10) being disposed, at least partly, in the first concrete slab (4) and the second metal beam (10) being disposed, at least partly, in the second concrete slab (6).
9. The floor according to one of the preceding claims, in which the load-bearing is produced of steel and in particular reinforcing steel.
10. The floor according to any of the previous claims, wherein a concrete layer (22, 32) is arranged on a surface formed by a number of adjacently installed concrete slabs (4, 6, 44, 46) of a number of construction elements (2, 42).
11. The floor according to any of the previous claims, wherein the space between the first concrete slab (4, 44) and the second concrete slabs (6, 46) is at least partially filled with cellular concrete, heavy concrete, thermal insulation material or sound insulation material.
12. Method for producing a floor according to any of the

claims 1-11, the method comprising the steps of:

- prefabricating construction elements (2, 42), the prefabricated construction elements comprising:

- a first concrete slab (4, 44) of a first length and a first width;
- a second concrete slab (6, 46) of a second length and a second width;
- wherein the first concrete slab and the second concrete slab are placed at a distance from one another as well as substantially parallel with respect to one another, and are connected by a load-bearing structure for forming a space between the first concrete slab and the second concrete slab;
- arranging adjacent prefabricated construction elements,
- wherein the adjacent first slabs are laterally abutting, and
- wherein said second width is smaller than said first width, such that an opening remains between the adjacent second concrete slabs;
- arranging a prefabricated panel (26) for covering the opening;
- **characterized in that** the outer surface of the prefabricated panel, together with the outer surface of the adjacent second slabs, forms an even floor and/or a continuous ceiling surface.

13. The method of claim 12, wherein said load-bearing element (8) comprises a first and a second metal beam (10) and metal bars (12) fitted in-between the latter, each pair of successive bars (12) forming a triangle with one of the metal beams (10) and production of the load-bearing element (8) comprising substantially simultaneously welding a bar (12) to the first beam (10) and to the second beam (10).

14. Method according to claim 13, wherein the step of welding of a bar (12) to a beam (10) comprises welding simultaneously along two seams.

#### Patentansprüche

1. Boden, umfassend vorgefertigte angrenzende Konstruktionsteile (2, 42), wobei die vorgefertigten Konstruktionsteile umfassen:
- eine erste Betonplatte (4, 44) einer ersten Länge und einer ersten Breite;
  - eine zweite Betonplatte (6, 46) einer zweiten Länge und einer zweiten Breite;
  - wobei die erste Betonplatte und die zweite Be-

- tonplatte beabstandet zueinander sowie im wesentlichen parallel zueinander angeordnet sind, und durch eine Tragekonstruktion verbunden sind, so dass ein Zwischenraum zwischen der ersten Betonplatte und der zweiten Betonplatte entsteht;
- wobei die zweite Breite kleiner ist als die erste Breite, so dass zwischen den angrenzenden zweiten Betonplatten eine Öffnung verbleibt;
  - wobei die angrenzenden ersten Platten seitlich aneinanderstoßen;
  - ein vorgefertigtes Paneel (26) zur Abdeckung der Öffnung;
  - **dadurch gekennzeichnet, dass** die Außenfläche des vorgefertigten Paneels zusammen mit der Außenfläche der angrenzenden zweiten Platten einen ebenen Boden bilden und/oder eine durchgehende Deckenfläche.
2. Boden nach Anspruch 1, **dadurch gekennzeichnet, dass** sich die Öffnung entlang der zweiten Länge der angrenzenden zweiten Betonplatten erstreckt.
  3. Boden nach Anspruch 1 oder 2, **dadurch gekennzeichnet, dass** das Paneel sich entlang der zweiten Länge der angrenzenden zweiten Betonplatten erstreckt.
  4. Boden nach einem der vorherigen Ansprüche, **dadurch gekennzeichnet, dass** das Paneel die Öffnung entfernbar bedeckt.
  5. Boden nach einem der vorherigen Ansprüche, **dadurch gekennzeichnet, dass** die zweite Länge kleiner ist, als die erste Länge.
  6. Boden nach einem der vorherigen Ansprüche, **dadurch gekennzeichnet, dass** die Tragekonstruktion (8) eine offene Struktur aufweist in Richtung der ersten Länge und der zweiten Länge und/oder in Richtung der ersten und zweiten Breite.
  7. Boden nach einem der vorherigen Ansprüche, **dadurch gekennzeichnet, dass** der Raum zwischen der ersten Betonplatte und der zweiten Betonplatte durch die Öffnung zugänglich ist.
  8. Boden nach einem der vorherigen Ansprüche, **dadurch gekennzeichnet, dass** die Tragekonstruktion eine Anzahl von Tragelementen (8, 20) umfasst, wobei jedes Tragelement (8) einen ersten und einen zweiten Metallträger (10) und zwischen Letztere eingepasste Metallstangen (12) umfasst, wobei jedes Paar aufeinanderfolgen-
- der Stangen (12) ein Dreieck mit einem der Metallträger (10) bildet, und der erste Metallträger (10) zumindest teilweise in der ersten Betonplatte (4) angeordnet ist und der zweite Metallträger (10) zumindest teilweise in der zweiten Betonplatte (6) angeordnet ist.
9. Boden nach einem der vorherigen Ansprüche, **dadurch gekennzeichnet, dass** die Tragekonstruktion aus Stahl, und insbesondere aus Betonstahl besteht.
  10. Boden nach einem der vorherigen Ansprüche, **dadurch gekennzeichnet, dass** eine Betonschüttung (22, 32) auf einer Fläche angeordnet ist, die aus einer Anzahl von angrenzend installierten Betonplatten (4, 6, 44, 46) einer Anzahl von Konstruktionselementen (2, 42) gebildet wird.
  11. Boden nach einem der vorherigen Ansprüche, **dadurch gekennzeichnet, dass** der Raum zwischen der ersten Betonplatte (4, 44) und den zweiten Betonplatten (6, 46) zumindest teilweise gefüllt ist mit Zellbeton, Schwerbeton, Wärmedämmungsmaterial oder Geräuschkämmungsmaterial.
  12. Verfahren zur Herstellung eines Bodens nach einem der Ansprüche 1 - 11, wobei das Verfahren die folgenden Schritte umfasst:
    - Vorfertigen von Konstruktionselementen (2, 42), wobei die vorgefertigten Konstruktionselemente umfassen:
      - eine erste Betonplatte (4, 44) einer ersten Länge und einer ersten Breite;
      - eine zweite Betonplatte (6, 46) einer zweiten Länge und einer zweiten Breite;
      - wobei die erste Betonplatte und die zweite Betonplatte beabstandet zueinander sowie im wesentlichen parallel zueinander angeordnet sind, und durch eine Tragekonstruktion verbunden sind, so dass ein Zwischenraum zwischen der ersten Betonplatte und der zweiten Betonplatte entsteht;
      - Anordnen angrenzender vorgefertigter Konstruktionselemente,
      - wobei die angrenzenden ersten Platten seitlich aneinanderstoßen, und
      - wobei die zweite Breite kleiner ist als die erste Breite, so dass zwischen den angrenzenden zweiten Betonplatten eine Öffnung verbleibt;
      - Anordnen eines vorgefertigten Paneels (26) zur Abdeckung der Öffnung;
      - **dadurch gekennzeichnet, dass** die Außenfläche des vorgefertigten Paneels zu-

sammen mit der Außenfläche der angrenzenden zweiten Platten einen ebenen Boden und/oder eine durchgängige Deckenfläche bilden.

13. Verfahren nach Anspruch 12, **dadurch gekennzeichnet, dass** das Trageelement (8) einen ersten und einen zweiten Metallträger (10) und zwischen Letztere eingepasste Metallstangen (12) umfasst, wobei jedes Paar aufeinanderfolgender Stangen (12) ein Dreieck mit einem der Metallträger (10) bildet, und wobei Herstellung des Tragelements (8) im Wesentlichen gleichzeitiges Anschweißen einer Stange (12) an den ersten Träger (10) und den zweiten Träger (10) umfasst.

14. Verfahren nach Anspruch 13, **dadurch gekennzeichnet, dass** der Schritt des Anschweißens einer Stange (12) an einen Träger (10) gleichzeitiges Schweißen entlang zweier Nähte umfasst.

#### Revendications

1. Plancher, comprenant des éléments de construction (2, 42) préfabriqués adjacents, les éléments de construction préfabriqués comprenant :

- une première plaque en béton (4, 44) d'une première longueur et d'une première largeur ;
- une deuxième plaque en béton (6, 46) d'une deuxième longueur et d'une deuxième largeur ;

dans lequel la première plaque en béton et la deuxième plaque en béton sont placées à une distance l'une de l'autre, ainsi que sensiblement parallèlement l'une à l'autre, et sont reliées par une structure porteuse de charge, pour former un espace entre la première plaque en béton et la deuxième plaque en béton ;

- dans lequel ladite deuxième largeur est plus petite que ladite première largeur, de manière qu'une ouverture subsiste entre les deuxièmes plaques en béton adjacentes ;
- dans lequel les premières plaques adjacentes sont mises latéralement en butée ;
- un panneau (26) préfabriqué, pour couvrir l'ouverture ;

**caractérisé en ce que** la surface extérieure du panneau préfabriqué, conjointement avec la surface extérieure des deuxièmes plaques adjacentes, forme un plancher plat et/ou une surface de plafond continue.

2. Plancher selon la revendication 1, dans lequel l'ouverture s'étend sur la deuxième longueur des deuxièmes plaques en béton adjacentes.

5 3. Plancher selon la revendication 1 ou 2, dans lequel le panneau s'étend sur la deuxième longueur des deuxièmes plaques en béton adjacentes.

10 4. Plancher selon l'une quelconque des revendications précédentes, dans lequel le panneau couvre de manière amovible l'ouverture.

15 5. Plancher selon l'une quelconque des revendications précédentes, dans lequel ladite deuxième longueur est plus petite que ladite première longueur.

6. Plancher selon l'une quelconque des revendications précédentes, dans lequel la structure porteuse de charge (8) présente une ouverture dans la direction de la première longueur et de la deuxième longueur et/ou dans la direction de la première et deuxième largeur.

25 7. Plancher selon l'une quelconque des revendications précédentes, dans lequel l'espace entre la première plaque en béton et la deuxième plaque en béton est accessible à travers l'ouverture.

30 8. Plancher selon l'une quelconque des revendications précédentes, dans lequel la structure porteuse de charge comprend une pluralité d'éléments porteurs de charge (8, 20), chaque élément porteur de charge (8) comprenant une première et une deuxième poutre métallique (10) et des barres métalliques (12) montées entre ces dernières, chaque paire de barres (12) successives formant un triangle avec l'une des poutres métalliques (10), et la première poutre métallique (10) étant disposée, au moins partiellement, dans la première plaque en béton (4), et la deuxième poutre métallique (10) étant disposée, au moins partiellement, dans la deuxième plaque en béton (6).

45 9. Plancher selon l'une quelconque des revendications précédentes, dans lequel la structure porteuse de charge est réalisée en acier et, en particulier, en acier de renforcement.

50 10. Plancher selon l'une quelconque des revendications précédentes, dans lequel une couche en béton (22, 32) est agencée sur une surface formée par une pluralité de plaques en béton (4, 6, 44, 46), installées de manière adjacente, d'une pluralité d'éléments de construction (2, 42).

55 11. Plancher selon l'une quelconque des revendications précédentes, dans lequel l'espace entre la première plaque en béton (4, 44) et la deuxième plaque en béton (6, 46) est rempli au moins partiellement avec

un béton cellulaire, un béton lourd, un matériau d'isolation thermique ou un matériau d'isolation phonique.

long de deux cordons.

12. Procédé de fabrication d'un plancher selon l'une quelconque des revendications 1 à 11, le procédé comprenant les étapes consistant à :
- préfabriquer des éléments de construction (2, 42), les éléments de construction préfabriqués comprenant :
    - une première plaque en béton (4, 44) d'une première longueur et d'une première largeur ;
    - une deuxième plaque en béton (6, 46) d'une deuxième longueur et d'une deuxième largeur ;
- dans lequel la première plaque en béton et la deuxième plaque en béton sont placées à une distance l'une de l'autre, ainsi que sensiblement parallèlement l'une à l'autre, et sont reliées par une structure porteuse de charge, pour former un espace entre la première plaque en béton et la deuxième plaque en béton ;
- agencer des éléments de construction préfabriqués adjacents,
  - dans lequel les premières plaques adjacentes sont mises latéralement en butée ; et
  - dans lequel ladite deuxième largeur est plus petite que ladite première largeur, de manière qu'une ouverture subsiste entre les deuxièmes plaques en béton adjacentes ;
  - agencer un panneau (26) préfabriqué, pour couvrir l'ouverture ;
- caractérisé en ce que** la surface extérieure du panneau préfabriqué, conjointement avec la surface extérieure des deuxièmes plaques adjacentes, forme un plancher plat et/ou une surface de plafond continue.
13. Procédé selon la revendication 12, dans lequel ledit élément porteur de charge (8) comprend une première et une deuxième poutre métallique (10) et des barres métalliques (12) montées entre ces dernières, chaque paire de barres (12) successives formant un triangle avec l'une des poutres métalliques (10), et la production de l'élément porteur de charge (8) comprenant le soudage pratiquement simultané d'une barre (12) à la première poutre (10) et à la deuxième poutre (10).
14. Procédé selon la revendication 13, dans lequel l'étape de soudage d'une barre (12) à une poutre (10) comprend un soudage effectué simultanément, le

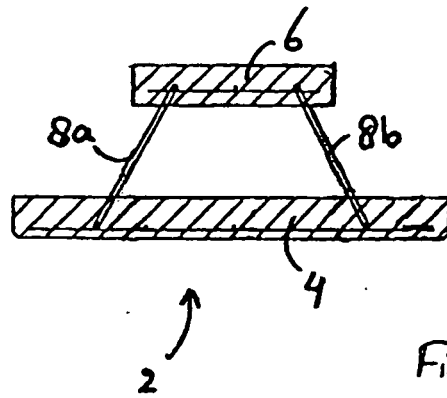

Fig. 1

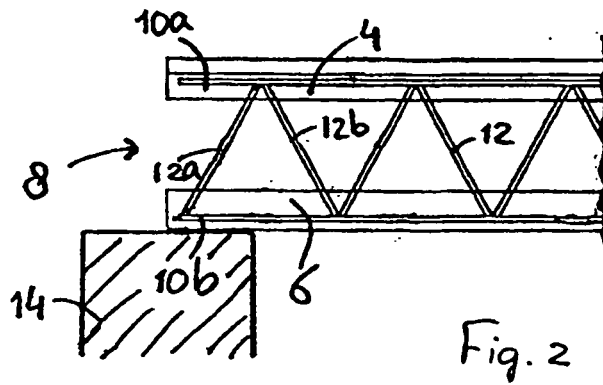

Fig. 2

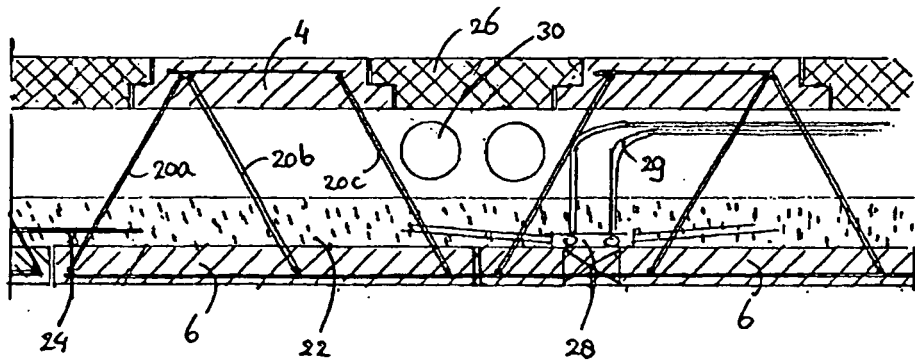

Fig. 3

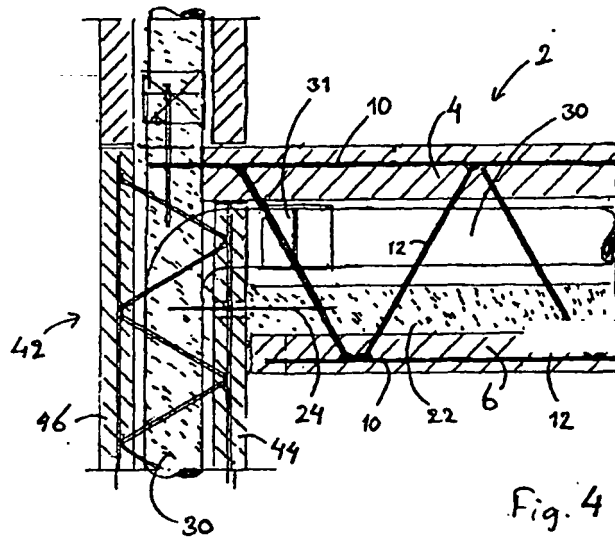

Fig. 4

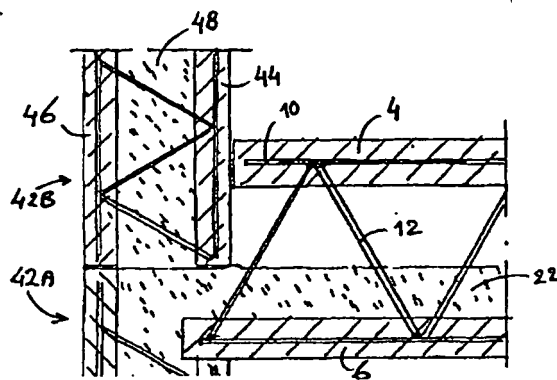

Fig. 5

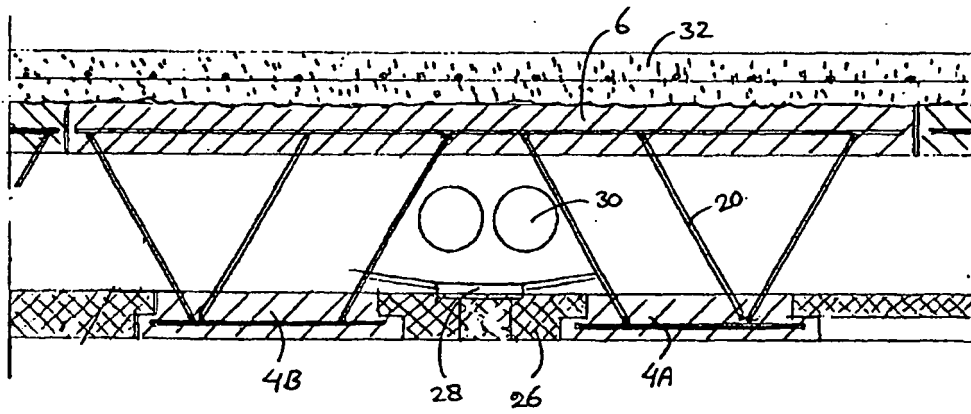

Fig. 6

**REFERENCES CITED IN THE DESCRIPTION**

*This list of references cited by the applicant is for the reader's convenience only. It does not form part of the European patent document. Even though great care has been taken in compiling the references, errors or omissions cannot be excluded and the EPO disclaims all liability in this regard.*

**Patent documents cited in the description**

- DE 4434499 A1 [0001]