



INTERNATIONAL APPLICATION PUBLISHED UNDER THE PATENT COOPERATION TREATY (PCT)

<p>(51) International Patent Classification ⁶ : B01D 25/176</p>	<p>A1</p>	<p>(11) International Publication Number: WO 96/24423 (43) International Publication Date: 15 August 1996 (15.08.96)</p>
<p>(21) International Application Number: PCT/GB96/00248 (22) International Filing Date: 7 February 1996 (07.02.96) (30) Priority Data: 9502486.5 9 February 1995 (09.02.95) GB (71) Applicant (for all designated States except US): SCAPA GROUP PLC [GB/GB]; Oakfield House, 93 Preston New Road, Blackburn, Lancashire BB2 6AY (GB). (72) Inventor; and (75) Inventor/Applicant (for US only): SCHROERS, Ernst-Dieter [DE/DE]; Berliner Strasse 124, D-4050 Monchengladbach 2 (DE). (74) Agents: GOODWIN, Mark et al.; Wilson Gunn M'Caw, 41-51 Royal Exchange, Cross Street, Manchester M2 7BD (GB).</p>		<p>(81) Designated States: AL, AM, AT, AU, AZ, BB, BG, BR, BY, CA, CH, CN, CZ, DE, DK, EE, ES, FI, GB, GE, HU, IS, JP, KE, KG, KP, KR, KZ, LK, LR, LS, LT, LU, LV, MD, MG, MK, MN, MW, MX, NO, NZ, PL, PT, RO, RU, SD, SE, SG, SI, SK, TJ, TM, TR, TT, UA, UG, US, UZ, VN, ARIPO patent (KE, LS, MW, SD, SZ, UG), Eurasian patent (AZ, BY, KG, KZ, RU, TJ, TM), European patent (AT, BE, CH, DE, DK, ES, FR, GB, GR, IE, IT, LU, MC, NL, PT, SE), OAPI patent (BF, BJ, CF, CG, CI, CM, GA, GN, ML, MR, NE, SN, TD, TG).</p> <p>Published With international search report. Before the expiration of the time limit for amending the claims and to be republished in the event of the receipt of amendments.</p>

(54) Title: FILTRATION APPARATUS

(57) Abstract

A filtration apparatus (10) for use in a filter press comprises a filter plate (11) having an aperture (15) therethrough and filter cloths (16, 17) having similar sized apertures (18, 19), the filter cloth (16, 17) being located respectively on opposite sides of the filter plate (11). The filter cloths (16, 17) are connected to the filter plate (11) by mating formations (14, 20) provided on the filter cloths (16, 17) and plate (11).

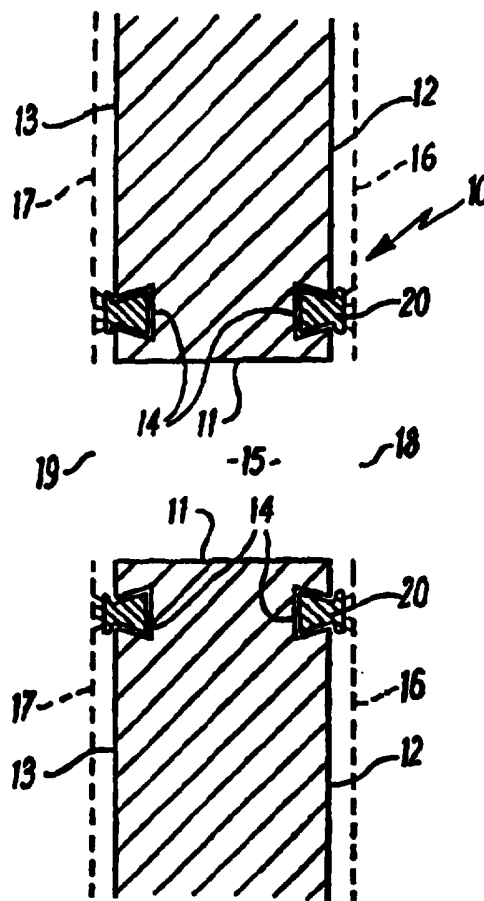

FOR THE PURPOSES OF INFORMATION ONLY

Codes used to identify States party to the PCT on the front pages of pamphlets publishing international applications under the PCT.

AM	Armenia	GB	United Kingdom	MW	Malawi
AT	Austria	GE	Georgia	MX	Mexico
AU	Australia	GN	Guinea	NE	Niger
BB	Barbados	GR	Greece	NL	Netherlands
BE	Belgium	HU	Hungary	NO	Norway
BF	Burkina Faso	IE	Ireland	NZ	New Zealand
BG	Bulgaria	IT	Italy	PL	Poland
BJ	Benin	JP	Japan	PT	Portugal
BR	Brazil	KE	Kenya	RO	Romania
BY	Belarus	KG	Kyrgyzstan	RU	Russian Federation
CA	Canada	KP	Democratic People's Republic of Korea	SD	Sudan
CF	Central African Republic	KR	Republic of Korea	SE	Sweden
CG	Congo	KZ	Kazakhstan	SG	Singapore
CH	Switzerland	LI	Liechtenstein	SI	Slovenia
CI	Côte d'Ivoire	LK	Sri Lanka	SK	Slovakia
CM	Cameroon	LR	Liberia	SN	Senegal
CN	China	LT	Lithuania	SZ	Swaziland
CS	Czechoslovakia	LU	Luxembourg	TD	Chad
CZ	Czech Republic	LV	Latvia	TG	Togo
DE	Germany	MC	Monaco	TJ	Tajikistan
DK	Denmark	MD	Republic of Moldova	TT	Trinidad and Tobago
EE	Estonia	MG	Madagascar	UA	Ukraine
ES	Spain	ML	Mali	UG	Uganda
FI	Finland	MN	Mongolia	US	United States of America
FR	France	MR	Mauritania	UZ	Uzbekistan
GA	Gabon			VN	Viet Nam

FILTRATION APPARATUS

The present invention relates to filtration apparatus and more particularly to a filter plate and filter cloth arrangement for use in a filter press.

The term "filter cloth" used herein in relation to the invention refers to any filter media such as filter fabrics and other sheets of filter materials such as sintered polymers, metals or ceramics.

It is known to provide on filter presses and some other filter types, filter plates having a slurry feed hole in the filtering area. Both sides of such a filter plate are covered with a layer of filter material and each layer is provided with a feed hole. It is necessary to prevent the slurry from escaping between the filter layers and the filter plate in the region of the feed hole.

In one known arrangement a connecting device consisting essentially of a short cylinder having a flange at one end and threaded at the other is passed through the feed hole of one layer, through the hole in the filter plate and through the hole in the other layer. An annular ring is placed over the projecting cylindrical portion and a nut is screwed onto the threaded portion so pressing the layers of filter material between the flanges and the filter plate to provide a seal. This type of fixing is difficult and time consuming to assemble and often difficult to dismantle when the filter fabric has reached the end of its useful life.

In another known arrangement the two layers of filter material are interconnected at the feed hole by a cylindrical

portion made from the filter cloth material which portion is stitched at one end to one layer and at the other end to the other layer to form a so called "barrel neck" filter cloth. The stitching operation is particularly time consuming and installing the filter cloth necessitates passing one layer of the cloth through the feed hole in the filter plate. Furthermore, if the filter cloth becomes hardened during use it is often impossible to remove the cloth without cutting. Thus removal for washing is prevented and the useful life of the filter cloth is reduced. Also if one side of the cloth becomes damaged the complete filter cloth must be disregarded.

In order to overcome the problem of stitching a known filter cloth (described in GB Patent Specification No. 1459099) of the "barrel neck" type utilises a hollow polymeric cylinder which is secured to the two layers of the filter cloth by heat bonding. However, the problems of fitting and removing the cloth still remain.

In another known arrangement described in German Published Patent Specification No. 2110860 a pair of filter cloths which cover the respective sides of a filter plate are each provided with a connecting device which is semi-circular in cross-section and which is made from an elastic deformable material. The device is secured to the filter cloth and when installed in the press the semi-circular portions of each device lay tightly over one another.

In practice the connections of this type have been found to be difficult to install because the semi-circular section must be deformed substantially. In addition some support is

required for the connection to ensure adequate sealing between the two components.

GB 2088231 describes a filter arrangement comprising two filter cloths on opposite sides of a filter press connected by a barrel neck connection. The barrel neck connection comprises two annular members each of which is secured to one of the filter cloths. The ends of the annular members are constructed to connect releasably together with a snap fit. However, such an arrangement is difficult to manufacture in a cost effective manner in that the rings must be made to a close tolerance if they are to fit together correctly. Furthermore, if the rings are manufactured to such a close tolerance they are difficult to prise apart and are often damaged in doing so. Hence, they cannot be reused.

The present invention has been made from a consideration of these problems.

According to a first aspect of the present invention there is provided a method of connecting a filter cloth to a filter plate, said filter cloth having an aperture extending therethrough and said filter plate having a hole extending therethrough, said method comprising the step of providing co-operating formations integrally with or secured to the filter plate and the filter cloth and bringing the formations into engagement such that the aperture provided through the filter cloth is aligned with the hole through the filter plate.

The filter cloth to be secured to the other side of the filter plate is ideally secured to the filter plate in the same manner.

According to a second aspect of the present invention there is provided a filtration apparatus comprising at least one filter cloth operable to be connected to a filter plate, said filter cloth having an aperture extending therethrough and said filter plate having a hole extending therethrough, co-operating formations being provided integrally with or secured to the filter plate and filter cloth, the co-operating formations being brought into engagement such that the aperture provided through the filter cloth is aligned with the hole through the filter plate.

The connector and method described above facilitate the easy mounting and dismounting of filter cloths on the filter plate without the need for a barrel neck connector. The assemblies of the invention are cheap to manufacture.

Any number of mating formations may be used. The co-operating formations ideally comprise a continuous seal around the filter cloth aperture so as to prevent leakage of the material being filtered. The continuous seal may have any shape. The co-operating formations may comprise a groove and mating projection. One of a pair of co-operating formations would most likely be provided integrally with the filter plate, whereas the other, co-operating formation would most likely be secured to the filter cloth, for example, by welding, adhesive or heat bonding of polymers.

The co-operating formations may be secured together simply by way of a press-fit, the projection being profiled so as to be captured by the groove. The ring profile should allow for ease of fit, but offer a high resistance to ring

removal once fitted. Mating may be aided by bonding, for example, using adhesives.

In a preferred embodiment of the invention the connecting formations on the cloth comprise a ring which is ideally made of an elastomeric material preferably have at least a 70° A Shore Hardness.

In order that the present invention may be more readily understood specific embodiments thereof will now be described by way of example only with reference to the accompanying drawings in which:-

Fig.1 is a cross section through one filtration apparatus in accordance with the invention;

Fig.2 is a cross section through a second filtration apparatus in accordance with the invention; and

Fig.3 is a cross section through a third filtration apparatus in accordance with the invention.

Referring to Fig.1 a filtration apparatus 10 for location in a chamber press filter comprises a filter plate 11 having major faces 12,13. The filter plate 11 is made from a polymer. A channel 15 extends through the filter plate. A tapered continuous annular groove 14 is provided on each face 12,13. A filter cloth 16,17 is located adjacent each face 12,13. Each filter cloth 16,17 has an aperture 18,19 therethrough, the aperture being in register with the channel 15. A ring 20 of elastomeric material is welded to each filter cloth, a ring 20 extending around each aperture 18,19. The rings 20 are tapered and are operative to fit into the grooves 14 with a snug fit. The profiling of the groove 14

and ring 20 is selected so as to capture the ring 20 in the groove 14.

Fig.2 shows a second filtration apparatus 21 similar to that illustrated in Fig.1 except in that a differently shaped groove and ring attachment is used.

Fig.3 shows a further filtration apparatus 22 in which a tapered projection 23 extends from the filter plate. The tapered projection 23 engages a grooved ring 24 which is welded to the filter cloth 25 around the aperture through the filter cloth.

It is to be understood that the above described embodiments are by way of illustration only. Many modifications and variations are possible.

CLAIMS

1. A method of connecting a filter cloth to a filter plate, said filter cloth having an aperture extending therethrough and said filter plate having a hole extending therethrough, said method comprising the step of providing co-operating formations integrally with or secured to the filter plate and the filter cloth and bringing the formations into engagement such that the aperture provided through the filter cloth is aligned with the hole through the filter plate.
2. A method as claimed in claim 1, wherein the co-operating formations ideally comprise a continuous seal around the filter cloth aperture so as to prevent leakage of the material being filtered.
3. A method as claimed in claim 1 or claim 2, wherein the co-operating formations comprise a groove and mating projection.
4. A method as claimed in any preceding claim, wherein one of a pair of co-operating formations is provided integrally with the filter plate.
5. A method as claimed in claim 4, wherein the other of the pair of co-operating formations is secured to the filter cloth.
6. A method as claimed in any of claims 3 to 5, wherein the projection is profiled so as to be captured by the groove.
7. A method as claimed in any of claims 3 to 6, wherein mating of the projection in the groove is aided by bonding.
8. A method as claimed in any of claims 3 to 7, wherein a projection is provided on the cloth, the projection comprising

a ring of elastomeric material.

9. A filtration apparatus operable to be connected to a filter plate, said filter cloth having an aperture extending therethrough and said filter plate having a hole extending therethrough, co-operating formations being provided integrally with or secured to the filter plate and filter cloth, the co-operating formations being brought into engagement such that the aperture provided through the filter cloth is aligned with the hole through the filter plate.

10. A filtration apparatus as claimed in claim 9, wherein the co-operating formations ideally comprise a continuous seal around the filter cloth aperture so as to prevent leakage of the material being filtered.

11. A filtration apparatus as claimed in claim 9 or claim 10, wherein the co-operating formations comprise a groove and mating projection.

12. A filtration apparatus as claimed in any of claims 9 to 11, wherein one of a pair of co-operating formations is provided integrally with the filter plate.

13. A filtration apparatus as claimed in claim 12, wherein the other of the pair of co-operating formations is secured to the filter cloth.

14. A filtration apparatus as claimed in any of claims 11 to 13, wherein the projection is profiled so as to be captured by the groove.

15. A filtration apparatus as claimed in any of claims 1 to 14, wherein mating of the projection in the groove is aided by bonding.

16. A filtration apparatus as claimed in any of claims 11 to 15, wherein the projection on the cloth comprises a ring of elastomeric material.

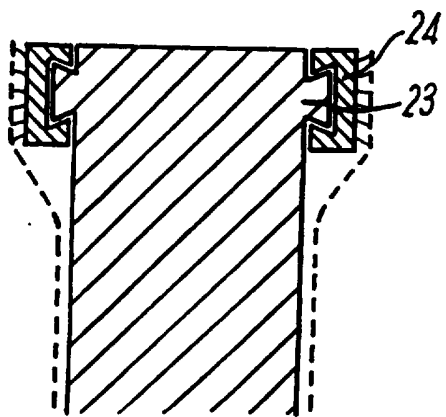
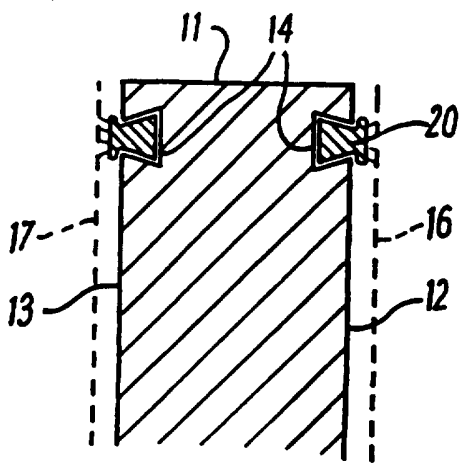
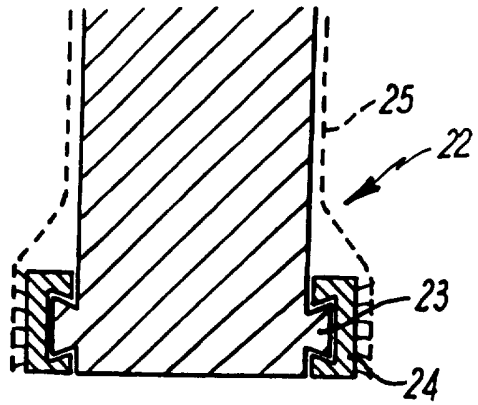
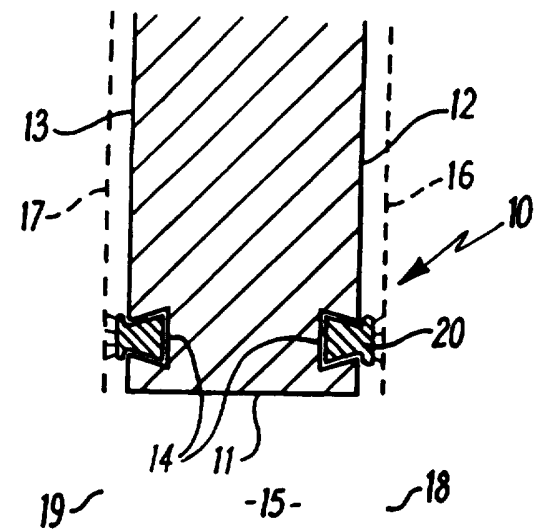

FIG. 1

FIG. 3

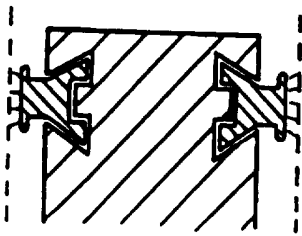
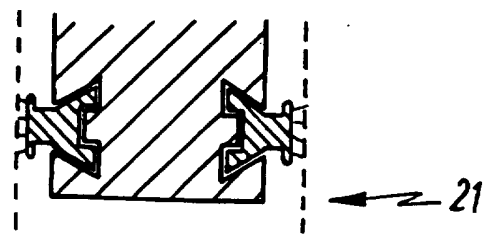

FIG. 2

INTERNATIONAL SEARCH REPORT

International Application No
PC 1/GB 96/00248

A. CLASSIFICATION OF SUBJECT MATTER
IPC 6 B01D25/176

According to International Patent Classification (IPC) or to both national classification and IPC

B. FIELDS SEARCHED

Minimum documentation searched (classification system followed by classification symbols)
IPC 6 B01D

Documentation searched other than minimum documentation to the extent that such documents are included in the fields searched

Electronic data base consulted during the international search (name of data base and, where practical, search terms used)

C. DOCUMENTS CONSIDERED TO BE RELEVANT

Category *	Citation of document, with indication, where appropriate, of the relevant passages	Relevant to claim No.
X	FR,A,2 643 826 (FIRMA PASSAVANT-WERKE AG.) 7 September 1990 see the whole document ---	1,9
A	DE,B,10 03 185 (FYLTIS-DIGONNET S.A.) 28 February 1957 see the whole document ---	1,9
A	BE,A,661 675 (TISSMETAL, LIONEL-DUPONT ET DES FONDERIES ET ATELIERS L. CHOQUENET) 16 July 1965 see figures ---	1,9
A	GB,A,2 146 545 (SHIRLY INSTITUTE) 24 April 1985 see the whole document ---	1,9
-/--		

Further documents are listed in the continuation of box C.

Patent family members are listed in annex.

* Special categories of cited documents :

- *A* document defining the general state of the art which is not considered to be of particular relevance
- *E* earlier document but published on or after the international filing date
- *L* document which may throw doubts on priority claim(s) or which is cited to establish the publication date of another citation or other special reason (as specified)
- *O* document referring to an oral disclosure, use, exhibition or other means
- *P* document published prior to the international filing date but later than the priority date claimed

- *T* later document published after the international filing date or priority date and not in conflict with the application but cited to understand the principle or theory underlying the invention
- *X* document of particular relevance; the claimed invention cannot be considered novel or cannot be considered to involve an inventive step when the document is taken alone
- *Y* document of particular relevance; the claimed invention cannot be considered to involve an inventive step when the document is combined with one or more other such documents, such combination being obvious to a person skilled in the art.
- *&* document member of the same patent family

Date of the actual completion of the international search

22 May 1996

Date of mailing of the international search report

06-06-1996

Name and mailing address of the ISA
European Patent Office, P.B. 5818 Patentlaan 2
NL - 2280 HV Rijswijk
Tel. (+ 31-70) 340-2040, Tx. 31 651 epo nl,
Fax: (+ 31-70) 340-3016

Authorized officer

Van Belleghem, W

INTERNATIONAL SEARCH REPORT

International Application No
PCT/GB 96/00248

C.(Continuation) DOCUMENTS CONSIDERED TO BE RELEVANT		
Category *	Citation of document, with indication, where appropriate, of the relevant passages	Relevant to claim No.
A	DE,U,91 08 330 (OTTO MARKET & SOHN) 10 December 1992 see page 5, paragraph 1; figure 2 -----	1,9

1

INTERNATIONAL SEARCH REPORT

information on patent family members

International Application No

PCT/GB 96/00248

Patent document cited in search report	Publication date	Patent family member(s)	Publication date
FR-A-2643826	07-09-90	DE-A- 3906537 US-A- 5011601	06-09-90 30-04-91

DE-B-1003185		NONE	

BE-A-661675	16-07-65	NL-A- 6504164	04-10-65

GB-A-2146545	24-04-85	NONE	

DE-U-9108330	29-10-92	AT-T- 137131 EP-A- 0521512	15-05-96 07-01-93
