



- (51) International Patent Classification:
B60B 27/00 (2006.01) B60K 1/04 (2019.01)
B60B 35/18 (2006.01)
- (21) International Application Number:
PCT/IB2021/057921
- (22) International Filing Date:
30 August 2021 (30.08.2021)
- (25) Filing Language: English
- (26) Publication Language: English
- (30) Priority Data:
277061 31 August 2020 (31.08.2020) IL
- (71) Applicant: REE AUTOMOTIVE LTD. [IL/IL]; 18 Shenkar St., 2nd floor, 4672517 Herzliya (IL).
- (72) Inventor: AKNIN, Amit; 29 Harishonim Street, 1292600 Karkom (IL).

(74) Agent: VAN DYKE, Marc; 150 Menachem Begin Road, WE Tower - Level 9, 6492105 Tel Aviv, HaMerkaz (IL).

(81) Designated States (unless otherwise indicated, for every kind of national protection available): AE, AG, AL, AM, AO, AT, AU, AZ, BA, BB, BG, BH, BN, BR, BW, BY, BZ, CA, CH, CL, CN, CO, CR, CU, CZ, DE, DJ, DK, DM, DO, DZ, EC, EE, EG, ES, FI, GB, GD, GE, GH, GM, GT, HN, HR, HU, ID, IL, IN, IR, IS, IT, JO, JP, KE, KG, KH, KN, KP, KR, KW, KZ, LA, LC, LK, LR, LS, LU, LY, MA, MD, ME, MG, MK, MN, MW, MX, MY, MZ, NA, NG, NI, NO, NZ, OM, PA, PE, PG, PH, PL, PT, QA, RO, RS, RU, RW, SA, SC, SD, SE, SG, SK, SL, ST, SV, SY, TH, TJ, TM, TN, TR, TT, TZ, UA, UG, US, UZ, VC, VN, WS, ZA, ZM, ZW.

(84) Designated States (unless otherwise indicated, for every kind of regional protection available): ARIPO (BW, GH, GM, KE, LR, LS, MW, MZ, NA, RW, SD, SL, ST, SZ, TZ, UG, ZM, ZW), Eurasian (AM, AZ, BY, KG, KZ, RU, TJ, TM), European (AL, AT, BE, BG, CH, CY, CZ, DE, DK, EE, ES, FI, FR, GB, GR, HR, HU, IE, IS, IT, LT, LU, LV,

(54) Title: WHEEL-DRIVE ASSEMBLY

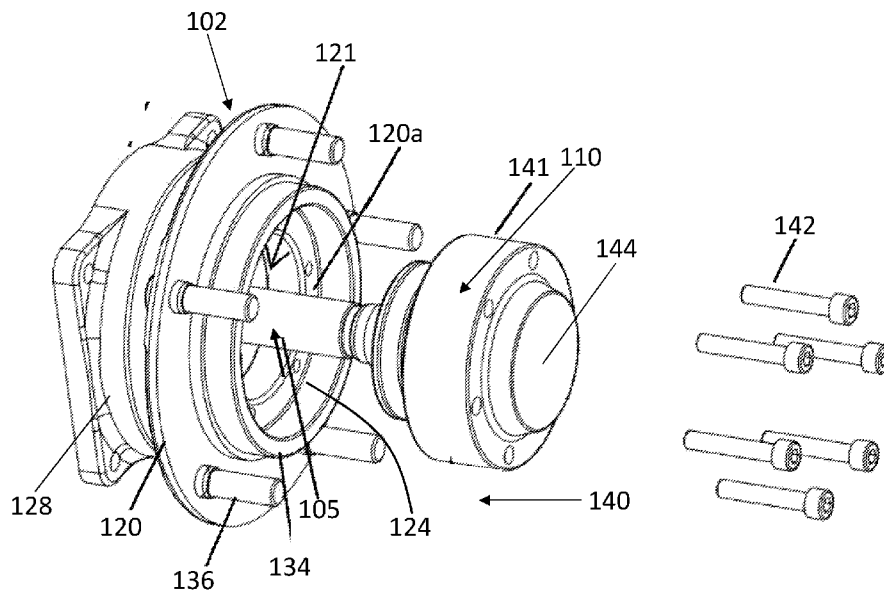

FIG. 5

(57) Abstract: A wheel drive assembly for transferring propelling torque from a source shaft to a wheel, the source shaft receiving torque from a motion actuator. The wheel drive assembly includes a wheel-hub, adapted to have the wheel mounted thereon, the wheel-hub being arranged about a longitudinal axis, which is adapted to coincide with a rotation axis of the wheel. The wheel drive assembly further includes a drive axle and a constant velocity (CV) joint mounted onto an outer end of the drive axle. The CV joint connects the drive axle to the wheel-hub. An outermost surface of the CV joint is disposed outwardly of an outermost surface of the wheel hub, along the longitudinal axis of the wheel-hub.



WO 2022/043959 A1

MC, MK, MT, NL, NO, PL, PT, RO, RS, SE, SI, SK, SM,
TR), OAPI (BF, BJ, CF, CG, CI, CM, GA, GN, GQ, GW,
KM, ML, MR, NE, SN, TD, TG).

Published:

- *with international search report (Art. 21(3))*
- *before the expiration of the time limit for amending the claims and to be republished in the event of receipt of amendments (Rule 48.2(h))*
- *in black and white; the international application as filed contained color or greyscale and is available for download from PATENTSCOPE*

WHEEL-DRIVE ASSEMBLY

CROSS-REFERENCE TO RELATED APPLICATIONS

This patent application claims the benefit of Israel Patent Application No. IL277061 filed on August 31, 2020, which is incorporated herein by reference in its entirety.

5

FIELD OF THE INVENTION

The present invention relates to vehicle wheel drives, and particularly to a wheel-drive assembly that transfers propulsive torque from a source to a vehicle wheel.

BACKGROUND OF THE INVENTION

10 In most vehicles, propelling torque from a motion actuator, e.g. an electric motor, an engine, or a transmission gear, is transferred to wheels of the vehicle using drive assemblies. Typically, each drive assembly transfers torque from the motion actuator located on the chassis of the vehicle to a wheel on one side of the chassis.

15 Figs. 1A and 1B (PRIOR ART) are schematic exploded view illustrations of a typical drive assembly. As seen, a typical drive assembly **10** includes a wheel-hub **12**, adapted to have a wheel **14** mounted thereon. Wheel **14** typically includes a tire **16** and a tire rim **18**, the tire rim being connected, or connectable, to wheel-hub **12**, for example using a plurality of fasteners such as lug nuts.

20 A drive shaft **19**, typically extends under the chassis of a vehicle between the engine and the wheel hub, and typically includes a drive axle **20**, which is also known as a half-shaft, functionally associated with a first constant velocity (CV) joint **22** and with a second CV joint **24**. First CV joint **22**, also known as an inboard CV joint, is functionally associated with an input shaft **26**, adapted to connect to an output of the motion actuator, and to receive propelling torque therefrom. Second CV joint **24**, also known as an outboard CV joint, is functionally
25 associated with an output shaft **28**, which is connected, or connectable, to wheel-hub **12**. Consequently, drive axle **20**, together with CV joints **22** and **24**, transfers torque from the motion actuator to wheel **14**, while allowing angular displacement between a rotational axis of the output shaft of the motion actuator and a rotational axis of wheel-hub **12**. Such angular displacement may be caused by motion of the wheel in various, non-rotating directions, such
30 as vertical travel of the wheel caused by uneven road surfaces.

US Patent Application Publication 2005/0257971 relates to a motor-driven wheel includes a wheel disc, a wheel hub, a knuckle, a hub bearing, a constant-velocity joint, an in-wheel motor, and a spring. The center of swing of the constant-velocity joint is placed closer to the outside of the vehicle relative to the hub bearing. Since such components of the constant-velocity joint as an inner race, balls and a cage are placed differently in position from the hub bearing, the hub bearing can be reduced in diameter. An outer race of the constant-velocity joint is integrated with the wheel hub into a single part and has an opening facing the outside of the vehicle. Since the opening is large and shallow, the work of installing the cage, balls and inner race and securing them with a snap ring is facilitated.

10

SUMMARY

According to an aspect of some embodiments of the present invention there is provided a wheel drive assembly for transferring propelling torque from a source shaft to a wheel, the source shaft receiving torque from a motion actuator, the wheel drive assembly including:

- 15 a) a wheel-hub, adapted to have the wheel mounted thereon, the wheel-hub being arranged about a longitudinal axis, which is adapted to coincide with a rotation axis of the wheel;
- b) a drive axle; and
- c) a constant velocity (CV) joint mounted onto an outer end of the drive axle, the CV joint
- 20 connecting the drive axle to the wheel-hub,

wherein an outermost surface of the CV joint is disposed outwardly of an outermost surface of the wheel hub, along the longitudinal axis of the wheel-hub.

In some embodiments, the drive axle includes a half shaft.

In some embodiments, wherein the CV joint includes a housing and a cage

25 accommodated within the housing. In some embodiments, the wheel-hub includes a seat at an outer side thereof, and wherein the housing engages the seat. In some embodiments, the housing engages the wheel-hub from an outer side of the wheel-hub.

In some embodiments, the housing is separable from the wheel hub. In some embodiments, in use of the CV joint, bearings of the CV joint are adapted rotate about an

30 interior surface of the housing.

In some embodiments, a majority of the CV joint is exposed exteriorly to the wheel hub.

In some embodiments, the wheel-drive assembly further includes an inner CV joint mounted onto an inner end of the drive axle, and adapted to be functionally coupled to the source shaft.

According to another aspect of some embodiments of the present invention there is provided a wheel assembly, including:

a wheel drive assembly as disclosed herein; and

a wheel including a tire and a tire rim, the tire rim mounted onto the wheel-hub, wherein at least a portion of the CV joint is visible from an outer side of the wheel.

In some embodiments, the wheel assembly further includes a disk brake and caliper, wherein at least a portion of the CV joint is exterior to the disk brake.

In some embodiments, an outermost surface of the cv joint extends outwardly of a central portion of the tire rim. In some embodiments, the outermost surface of the CV joint extends outwardly of the majority of the tire rim. In some embodiments, the outermost surface of the CV joint extends outwardly of the entirety of the tire rim.

In some embodiments, the wheel assembly further includes, or is functionally associated with, a steering assembly adapted to steer the wheel hub about a steering pivot point, wherein the steering pivot point does not coincide with a pivot point of the CV joint.

In some embodiments, when the steering assembly steers the wheel hub at a steering angle δ , the CV joint swings at a swing angle γ , swing angle γ being smaller than steering angle δ . In some embodiments, a ratio between swing angle γ and steering angle δ is not greater than 1:1.5.

According to yet another aspect of some embodiments of the present invention there is provided a vehicle, including:

a chassis;

at least one motion actuator, functionally associated with the chassis, the motion actuator having an output shaft; and

at least one wheel assembly as disclosed herein,

wherein the wheel drive assembly of the at least one wheel assembly is functionally associated with the output shaft of the motion actuator, as the source shaft, and the at least one wheel assembly is adapted to transfer propelling torque from the at least one motion actuator to the wheel of the at least one wheel assembly.

In some embodiments, the wheel drive assembly further includes an inner CV joint mounted onto an inner end of the drive axle, the inner CV joint being functionally coupled to

the output shaft of the motion actuator. In some embodiments, the inner CV joint is disposed at a laterally exterior edge of the chassis. In some embodiments, the inner CV joint is vertically stationary with respect to the chassis, and the outer CV joint is vertically movable with respect to the chassis, within a predetermined angular range of the drive axle relative to the chassis.

5 In some embodiments, the motion actuator is attached to the chassis, and functions as a sprung mass.

According to a further aspect of some embodiments of the present invention there is provided a vehicle, including:

a chassis;

10 at least one motion actuator, functionally associated with the chassis, the motion actuator having an output shaft; and

at least one wheel assembly, including:

a wheel-hub arranged about a longitudinal axis;

a drive axle;

15 a constant velocity (CV) joint mounted onto an outer end of the drive axle, the CV joint connecting the drive axle to the wheel-hub; and

a wheel including a tire and a tire rim, the tire rim mounted onto the wheel-hub such that the longitudinal axis of the wheel-hub coincides with a rotational axis of the wheel,

20 the wheel assembly being functionally associated with the output shaft of the motion actuator, as the source shaft, and the drive axle and CV joint are adapted to transfer propelling torque from the at least one motion actuator to the wheel; and

a steering assembly, functionally associated with the wheel-hub and adapted to steer the wheel by pivoting the wheel-hub and the wheel about a steering pivot point, wherein the steering pivot point does not coincide with a pivot point of the CV joint.

25 In some embodiments, when the steering assembly steers the wheel hub at a steering angle δ , the CV joint swings at a swing angle γ , swing angle γ being smaller than steering angle δ .

According to yet a further aspect of some embodiments of the present invention there is provided a vehicle, including:

a chassis;

30 at least one motion actuator, functionally associated with the chassis, the motion actuator having an output shaft; and

at least one wheel assembly, including:

a wheel-hub arranged about a longitudinal axis;

a drive axle;

5 a constant velocity (CV) joint mounted onto an outer end of the drive axle, the CV joint connecting the drive axle to the wheel-hub; and

a wheel including a tire and a tire rim, the tire rim mounted onto the wheel-hub, the wheel assembly being functionally associated with the output shaft of the motion actuator, as the source shaft, and the drive axle and CV joint are adapted to transfer propelling torque from the at least one motion actuator to the wheel; and

10 a steering assembly, functionally associated with the wheel-hub and adapted to steer the wheel by pivoting the wheel-hub and the wheel about a steering pivot point, wherein the steering pivot point does not coincide with a pivot point of the CV joint,

wherein, when the steering assembly steers the wheel hub at a steering angle δ , the CV joint swings at a swing angle γ , swing angle γ being smaller than steering angle δ .

15 In some embodiments, a ratio between swing angle γ and steering angle δ is not greater than 1:1.5.

In some embodiments, an outermost surface of the CV joint is disposed outwardly of an outermost surface of the wheel hub, along the longitudinal axis of the wheel-hub.

20 In some embodiments, at least a portion of the CV joint is visible from an outer side of the wheel.

In some embodiments, the wheel drive assembly further includes an inner CV joint mounted onto an inner end of the drive axle, the inner CV joint being functionally coupled to the output shaft of the motion actuator. In some embodiments, the inner CV joint is disposed at a laterally exterior edge of the chassis. In some embodiments, the inner CV joint is vertically stationary with respect to the chassis, and the outer CV joint is vertically movable with respect to the chassis, within a predetermined angular range of the drive axle relative to the chassis.

In some embodiments, the motion actuator is attached to the chassis, and functions as a sprung mass.

30 According to another aspect of some embodiments of the present invention there is provided a method for enabling transfer of propelling torque from a motion actuator of a vehicle, having an output shaft, to a wheel of the vehicle, using a drive shaft, a the method including:

fastening an outer CV joint of the drive shaft to an outer side of the wheel-hub;

connecting an inner CV joint of the drive shaft to the output shaft of the motion actuator; and

mounting a wheel on the wheel hub,

wherein, following the fastening, an outermost surface of the CV joint is disposed outwardly of an outermost surface of the wheel hub.

In some embodiments, the mounting of the wheel on the wheel hub occurs prior to the fastening of the outer CV joint.

In some embodiments, the method further includes, prior to the fastening, inserting the outer CV joint into the wheel hub from an exterior side of the wheel hub. In some embodiments, the wheel-hub includes an outer-side seat, and the inserting of the outer CV joint includes accommodating the outer CV joint in the outer-side seat.

In some embodiments, the wheel includes a tire mounted onto a tire rim, and the mounting of the wheel on the wheel hub includes fastening the tire rim to the wheel-hub.

In some embodiments, the outermost surface of the outer CV joint extends outwardly of a central portion of the tire rim. In some embodiments, the outermost surface of the outer CV joint extends outwardly of the majority of the tire rim. In some embodiments, the outermost surface of the outer CV joint extends outwardly of the entirety of the tire rim.

In some embodiments, the connecting of an inner CV joint includes placing the inner CV joint at an exterior edge of a chassis of the vehicle.

Unless otherwise defined, all technical and/or scientific terms used herein have the same meaning as commonly understood by one of ordinary skill in the art to which the invention pertains. In the case of conflict, the specification, including any definitions therein, will take precedence.

As used herein, the terms "comprising", "including", "having" and grammatical variants thereof are to be taken as specifying the stated features, integers, steps or components but do not preclude the addition of one or more additional features, integers, steps, components or groups thereof. These terms encompass the terms "consisting of" and "consisting essentially of".

As used herein, the term "or" is a logical operator combining two Boolean input conditions into a Boolean compound condition, such that the compound condition is satisfied if and only if at least one of the two input conditions is satisfied. In other words, if condition C = condition A or condition B, then condition C is not satisfied when both condition A and condition B are not satisfied, but is satisfied in each of the following cases: (i) condition A is

satisfied and condition B is not satisfied, (ii) condition A is not satisfied and condition B is satisfied, and (iii) both condition A and condition B are satisfied.

As used herein, the term "inboard" designates a component of an assembly which is at a location or side facing in the direction of the motion actuator (or in the direction of the chassis). Inversely, the term "outboard" designates a component of an assembly which is at a location or side facing away from the motion actuator, in the direction of the wheel.

As used herein, the terms "inward" and "interior" relate to a location or side of a component facing toward, or being closer to, a longitudinal centerline of a vehicle. Often, components that are further inward, or more interior, face the motion actuator of the vehicle. Inversely, the terms "outward" and "exterior" relate to a location or side of a component facing away from, or being further from, a longitudinal centerline of a vehicle. Often, components that are further outward, or more exterior, face the wheel of the vehicle.

BRIEF DESCRIPTION OF THE DRAWINGS

Some embodiments of the invention are herein described, by way of example only, with reference to the accompanying drawings. With specific reference now to the drawings in detail, it is stressed that the particulars shown are by way of example and for purposes of illustrative discussion of embodiments of the invention. In this regard, the description taken with the drawings makes apparent to those skilled in the art how embodiments of the invention may be practiced. In the drawings:

Figs. 1A and 1B (PRIOR ART) are schematic exploded view illustrations of a typical prior art drive assembly;

Fig. 1C (PRIOR ART) is a schematic front view representation of a vehicle including prior art wheel drive assemblies, as shown in Figs. 1A and 1B;

Fig. 2 (PRIOR ART) is a schematic illustration comparing the angular tolerances of drive axles of different lengths;

Fig. 3 is an exploded perspective view illustration of a wheel-drive assembly according to embodiments of the disclosed technology;

Figs. 4A and 4B are, respectively, a side view illustration and a cross sectional illustration of a wheel-hub forming part of the wheel-drive assembly of Fig. 4, according to embodiments of the disclosed technology;

Fig. 5 is a perspective view illustration of a method of connecting components of the wheel-drive assembly of Fig. 3, according to embodiments of the disclosed technology;

Figs. 6A and 6B are, respectively, front and back perspective view illustrations of the wheel-drive assembly of Fig. 3 according to embodiments of the disclosed technology, Fig. 6B having a the wheel added thereto;

Fig. 7 is a partially cut-away perspective view illustration of the wheel-drive assembly of Fig. 3, the cut-away portion revealing components of a CV joint forming part of the wheel-drive assembly;

Figs. 8A and 8B are sectional illustrations of the wheel-drive assembly of Fig. 3, Fig. 8A being a close-up of a central portion of Fig. 8B;

Fig. 9 is schematic front view representation of a vehicle including wheel drive assemblies of Figs. 3 to 8B, according to embodiments of the disclosed technology;

Figs. 10A and 10B are schematic side view illustrations of a wheel connected to the wheel drive assembly of Figs. 4 to 8B, in two steering situations; and

Fig. 11 is a schematic flow chart of a method for transferring propelling torque from a motion actuator of a vehicle to a wheel of a vehicle, using the wheel drive assembly of the disclosed technology, according to some embodiments thereof.

DETAILED DESCRIPTION OF SOME EMBODIMENTS OF THE INVENTION

The present invention relates to vehicle wheel drives, and particularly to a wheel-drive assembly that transfers propulsive torque from a source to a vehicle wheel.

Technical aspects addressed by the present invention

In applications such as when using a motor that is located close to the wheel, it is desirable to reduce the distance between the motion actuator, such as a motor or engine, and the wheel. However, even with the reduced distance, there must be sufficient range of motion between the wheel and the chassis, e.g. for vertical travel and/or for steering of the wheel.

One way to reduce the distance between the motion actuator and the wheel, or wheel-hub, is by shortening the length of drive axle **20**. As explained herein, this method may be problematic when CV joints **22** and **24** need to compensate for angular movement of the drive axle, caused, for example, by vertical motion of the wheel relative to the chassis.

Reference is now additionally made to Fig. 1C (PRIOR ART), which is a schematic front view representation of a vehicle including prior art wheel drive assemblies, as shown in Fig. 1A. As seen, in a typical prior art vehicle **30**, a powertrain **32** of the motor or engine of the vehicle is located under the chassis **34**. Torque is transferred from powertrain **32** to wheel **14** via drive axle **20** and wheel-hub **16**. In typical prior art drive assemblies, the second,

outboard, the CV joint of drive axle **20** is connected to an inboard side of wheel-hub **16**, and does not extend into the wheel hub.

Reference is now additionally made to Fig. 2 (PRIOR ART), which is a schematic illustration comparing the angular tolerances of drive axles of different lengths. In Fig. 2, it is assumed that the motion actuator, e.g. an electric motor, is fixed to the chassis of the vehicle. As such, first (inboard) CV joint **22**, which is fixed to the chassis via the motion actuator, is disposed at a fixed height relative to the vehicle platform (chassis).

When there is a disturbance to the wheel, e.g. the wheel goes into a pot hole, the wheel shifts vertically, causing second CV joint **24** to move downward. When the wheel shifts vertically by a distance **d**, the length of drive axle **20** impacts the angular tolerance required from the second CV joint in order to accommodate for the vertical motion of the wheel.

As seen in Fig. 2, when the drive axle **20a** has a first length **L1** and the distance between first CV joint **22** and second CV joint **24a** is **L1**, in order to facilitate a vertical motion of the wheel to a distance **d**, the drive axle must be disposed at an angle of **x** degrees from the horizontal, which must be accommodated by second CV joint **24a**. However, when the drive axle **20b** is shorter and has a length **L2 < L1**, the distance between first CV joint **22** and second CV joint **24b** is **L2**. In order to facilitate a vertical motion of the wheel to the distance **d**, the drive axle must be disposed at an angle of **y** degrees from the horizontal, which must be accommodated by second CV joint **24b**. Given that distance **d** is the same in both scenarios, and drive axle **20a** is shorter than drive axle **20b**, in accordance with basic geometry, e.g. the Pythagorean theorem, **y > x**. As a result, greater tolerance is required from CV joint **24b** than from CV joint **24a**.

As such, if the maximal tolerance of the second CV joint is fixed regardless of the length of the drive axle, a longer drive axle allows the wheel-drive assembly to accommodate greater vertical distances traversed by the wheel, than a shorter drive axle. It is possible that a system including a shorter drive axle would not have sufficient tolerance to accommodate the angular shift (**y**) associated with a specific vertical distance, and thus, that shortening the drive axle would not provide a suitable solution.

There is thus a need in the art for a wheel-drive assembly which has a small distance between the motion actuator and the wheel, while accommodating sufficient range of motion between the wheel and chassis, e.g. for vertical travel and/or for steering of the wheel.

Additionally, the maximal swing angle of a CV joint is typically more limited than a steering angle of the wheel-hub or wheel. Typically, the steering angle of the wheel is

dependent on motion of the CV joint, and because the range of the swing angle is typically smaller than the largest theoretical steering angle, in practice, the maximal steering angle is limited by the range of the swing angle.

As such, there is a need in the art for a wheel-drive assembly in which the steering angle is decoupled from the CV-joint swing angle. Alternately, there is a need in the art for a wheel-drive assembly in which the range of the CV-joint swing angle facilitates a steering angle which is greater than the swing angle.

Before explaining at least one embodiment of the invention in detail, it is to be understood that the invention is not necessarily limited in its application to the details of construction and the arrangement of the components and/or methods set forth in the following description and/or illustrated in the drawings and/or the Examples. The invention is capable of other embodiments or of being practiced or carried out in various ways.

Reference is now made to Fig. 3, which is an exploded perspective view illustration of a wheel-drive assembly **100** according to embodiments of the disclosed technology. As seen, wheel-drive assembly **100** includes a wheel hub **102**, adapted to have a wheel **104** mounted thereon. Wheel-drive assembly **100** further includes a drive shaft **105**. Drive shaft **105** includes a drive axle **106**, being functionally associated with a first, inboard, CV joint **108**, mounted onto an inner end of the drive axle, and with a second, outboard, CV joint **110**, mounted onto an outer end of the drive axle. First CV joint **108** is adapted to connect to an output shaft of a motion actuator, and second CV joint **110** is adapted to connect drive axle **106** to wheel-hub **102**. Drive shaft **105** is configured to transfer propelling torque from the motion actuator to the wheel.

Wheel **104** may include a tire rim **112** and a tire **114**. In some embodiments, a wheel cover (not explicitly shown) attaches to the tire rim to cover up other components of the wheel-drive assembly, such as the wheel-hub and/or the CV joint.

In some embodiments, wheel-drive assembly **100**, or a wheel assembly including wheel drive assembly **100**, includes wheel-brake components, such as a brake disc **116** and a caliper **118**.

In some embodiments, drive shaft **105** may be a standard drive shaft, such as a Rzeppa CV Front Driveshaft commercially available from Teraflex Inc. of Utah, USA. In some embodiments, drive shaft **105** may be a customized or custom-made drive shaft.

Reference is now made to Figs. 4A and 4B, which are, respectively, a side view illustration and a cross sectional illustration of an exemplary wheel-hub **102** of wheel-drive assembly **100**, according to embodiments of the disclosed technology.

As seen, wheel-hub **102** includes an annular wall **120**, defining a bore **121** and having extending therefrom an inner portion **122** and an outer portion **124**. Inner portion **122** is generally cylindrical, though a circumscribed bore **126** thereof has a greater diameter at an area distal to wall **120** than at an area proximal to wall **120**. A circumscribing ring **128** surrounds inner portion **122**, such that ball bearings **130** are disposed between circumscribing ring **128** and inner portion **122**.

According to some embodiments, as shown from example in Figs. 4A and 4B, outer portion **124** is a protruding outer portion which is substantially cylindrical and extends outwardly from annular wall **120**. In some embodiments, the diameter of a bore **132** within outer cowl portion **124** is greater than the diameter of bore **121**. Consequently, a cavity is formed by an outer surface **120a** of wall **120** and surrounding outer cowl portion **124**. As explained in further detail hereinbelow, surface **120a** defines a seat for a portion of drive shaft **105**, disposed within the cavity. Cowl portion **124** terminates in an outward facing surface **134**, which is also the outermost surface of wheel-hub **102**.

In some embodiments, fasteners **136** may be disposed in wall **120**, surrounding bore **121** thereof for engagement between wheel-hub **102** and wheel **104**.

Reference is now made to Fig. 5, which is a perspective view illustration of a method of connecting components of wheel-drive assembly **100**, according to embodiments of the disclosed technology.

As seen in Fig. 5, drive shaft **105**, and more specifically inboard CV joint **108** thereof, is inserted into bore **132** of cowl portion **124** of wheel-hub **102**, from an outer side thereof, and is moved toward the interior of wheel-hub **102**, e.g. into bores **121** and **126**, in the direction of arrow **140**. Drive shaft **105** is moved in the direction of arrow **140** until a housing **141** of outboard CV joint **110** is disposed within the cavity of cowl portion **124**, and engages the seat defined by surface **120a**. Fasteners **142** are used to fasten outboard CV joint **110** to surface **120a** of wheel-hub **102**.

Reference is now additionally made to Figs. 6A and 6B, which are, respectively, front and back perspective view illustrations of wheel-drive assembly **100** according to embodiments of the disclosed technology, Fig. 6B having wheel **104** added thereto.

As seen, housing **141** of outboard CV joint **110** is disposed within wheel-hub **102**, and specifically within cowl portion **124** thereof, such that a portion of the housing, and in some cases a majority of the housing, is exterior to outermost surface **134** of wheel-hub **102**. Stated differently, a portion of outboard CV joint **110**, and in some embodiments the majority of the outboard CV joint, is exposed laterally outside of wheel-hub **102**.

According to some embodiments, for example as shown in Fig. 6A, an outermost surface **144** of housing **141** is disposed outwardly to outermost surface **134** of wheel-hub **102**, and as a result is disposed outwardly to the entirety of wheel-hub **102**. In this context, fasteners **136** are not considered to form part of wheel-hub **102**, but rather are separate components adapted to connect wheel-hub **102** to wheel **104**. As seen, drive axle **106** extends through wheel-hub **102**, and interiorly beyond the wheel hub, such that inboard CV joint **108** is interior to the entirety of wheel-hub **102**.

Additionally, a portion of CV joint **110**, and in some embodiments the entirety of CV joint **110**, is disposed exterior to disk brake **116**, as seen in Fig. 6B.

As described herein, outboard CV joint **110** is fixedly attached to wheel hub **102** by fasteners **142**, and as such propelling torque received by drive axle **106**, is transferred to wheel-hub **102**, and to wheel **104**, by CV joint **110**.

Reference is now made to Fig. 7, which is a partially cut-away perspective view illustration of wheel-drive assembly **100**, the cut-away portion revealing components of outboard CV joint **110** of drive shaft **105** of the wheel-drive assembly. Reference is additionally made to Figs. 8A and 8B, which are sectional illustrations of wheel-drive assembly **100** when connected to wheel **104**.

As seen in Fig. 7, outboard CV joint **110** includes housing **141**, which is fastened by fasteners **142** to annular wall **120** of wheel-hub **102**. A cage **150** of CV joint **110** is disposed within housing **141**, and a boot **152** connects cage **150** to drive axle **106** of the drive shaft. Ball bearings of CV joint **110** are adapted to be disposed in cavities of cage **150**, and to rotate against an inside surface of housing **141**. As seen, there is at least a portion of inner portion **120** of the wheel-hub into which CV joint **110** does not extend, and which is not engaged by CV joint **110**. As seen, an inward end of CV joint **110** is disposed laterally outwardly of an inner most surface of inner portion **120** (along the longitudinal axis of the wheel hub).

As seen, housing **141** abuts, and is seated against, surface **120a** of annular wall **120**, such that a portion of housing **141**, and in some cases a majority of housing **141**, extends laterally exteriorly to outermost surface **134** of wheel-hub **102**. Additionally, a portion of cage

150, and in some cases a majority of cage **150**, extends laterally exteriorly to outermost surface **134** of wheel hub **102**. As seen in Figs. 5 and 7, housing **141** of CV joint **110** is separable from wheel-hub **102**. In this context, the term “separable” mean that the housing can be separated from the wheel-hub, while maintaining its function as a housing surrounding cage **150**.

5 As mentioned hereinabove, it is a particular feature of some embodiments of the present invention that the CV joint is separable from, and need not be integrated with, the wheel-hub. In some embodiments, this may reduce wear between the wheel-hub and the CV joint, and may ease replacement of the CV joint when it is necessitated by wear of the CV-joint. Additionally, some embodiments of the disclosed technology may use “off the shelf”
10 standard CV joints, and the wheel hub may be designed to accommodate CV joint of different types and/or sizes.

In some embodiments of the disclosed technology, the materials of the wheel-hub and the CV joint are independent of one another, since the wheel-hub does not engage bearings of the CV-joint. Thus, the selection of materials for the wheel-hub and CV joint is not constrained
15 by interaction of CV-joint bearings with the wheel-hub.

In some embodiments of the disclosed technology, the drive shaft may be tested independently of the wheel-hub, or externally to the wheel-hub, for example prior to installing the drive shaft.

Turning to Fig. 8B, it is seen that tire rim **112** includes a central wall portion **160**, which
20 is fastened to wheel-hub **102**. An angled surface **162** extends radially and longitudinally outwardly from central wall portion **160** to an extremity **164** of the tire rim. A second angled surface **166** extends radially outwardly and longitudinally inwardly from extremity **164** of the tire rim, and is adapted to have the tire mounted thereon.

As seen in Fig. 8A, outermost surface **144** of housing **141** extends laterally outwardly
25 of central portion **160** of tire rim **112**. In some embodiments, such as the illustrated embodiment, outermost surface **144** extends outwardly of the majority of tire rim **112** (in a direction along the rotational axis of the tire rim and of the wheel), and in some cases, such as in the illustrated embodiment, extends outwardly of extremity **164**, and thus outwardly of the entirety of tire rim **112**.

30 Reference is now made to Fig. 9, which is a schematic front view representation of a vehicle including wheel drive assemblies **100**, according to embodiments of the disclosed technology. Fig. 9 uses reference numerals similar to those of Fig. 1C.

As seen, in a vehicle **30'** according to the present invention, a powertrain **32'** of the motor or engine of the vehicle is located along an exterior lateral side of the chassis **34**, and is fixed thereto. Torque is transferred from powertrain **32'** to wheel **104** via drive shaft **105** and wheel-hub **102**. As described hereinabove, the outboard CV joint of the drive shaft **105** is disposed exterior to wheel-hub **102**, such that the drive axle extends along the length of the wheel-hub. Additionally, the inboard CV joint of the drive shaft **105** is connected to powertrain **32'** and as such is disposed at a laterally exterior edge of chassis **34**. The inboard CV joint is fixed to the chassis via powertrain **32'**, and is disposed at a fixed height relative to the chassis.

When there is a disturbance to the wheel, e.g. the wheel goes into a pot hole, the wheel shifts vertically, causing the outboard CV joint to move downward, relative to the chassis, within a predetermined angular range of the drive shaft **105**.

The connection of the drive axle to the laterally outward side of the wheel-hub, together with the powertrain being installed on the side of the chassis, allows for a reduced distance between the powertrain and the wheel, while maintaining the angular range of the wheels and of the CV joint, as explained herein.

It is a particular feature of the present invention that the placement of drive shaft **105**, and particularly the mounting of outboard CV joint **110** exteriorly of wheel-hub **102**, shortens the distance between the wheel-hub and the motion actuator, relative to a setting in which the outboard CV joint is attached to an interior side of the wheel-hub. This in turn shortens the distance between an exterior side of the wheel and the motion actuator, or between the exterior side of the wheel and the center of the chassis.

However, because drive axle **106** is not shorter than in prior art embodiments, and in fact drive shaft **105** may be an off-the-shelf unit, the angular range that the drive shaft must handle is unchanged relative to prior art vehicles using the same drive shaft.

As such, the novel placement of the outboard CV joint, as discussed herein, reduces the distance between the wheel and the center of the chassis, or between the wheel and the motion actuator, while addressing the problem described hereinabove with respect to Fig. 2.

Reference is now made to Figs. 10A and 10B, which are schematic side view illustrations of a wheel connected to the wheel drive assembly of Figs. 4 to 8B, in two steering situations.

As seen in Figs. 10A and 10B, wheel **104** is mounted onto wheel-hub **102**. Outboard CV-joint **110** of drive shaft **105** is connected to wheel-hub **102**, according to the present invention, as described hereinabove. The wheel-hub, or the wheel, is further connected to a

steering assembly **170**, adapted to steer the wheel-hub and the wheel about a steering pivot point **172**. The rotational axis of the wheel is indicated by reference numeral **182**.

In the state of Fig. 10A, a longitudinal axis of drive shaft **105** coincides with rotational axis **182**.

5 In Fig. 10B, steering assembly **170** has rotated wheel-hub **102** and wheel **104** by a steering angle δ . Steering of wheel **104** by angle δ is supported by rotation of drive shaft **105** by a swing angle γ . Stated differently, to maintain driving of wheel hub **102** by drive shaft **105**, longitudinal axis **184** of drive shaft **105** swings to an angle γ relative to its position in Fig. 10A, and relative to the rotational axis **182** of the wheel.

10 It is a particular feature of the present invention, that because of the novel placement of CV joint **110** within wheel hub **102**, the steering angle δ need not be equal to, and may be larger than, the swing angle γ . In some embodiments, because of the novel placement of CV joint **110** within wheel hub **102**, the steering pivot point **172** does not coincide with, and is at a distance from, a pivot point of CV joint **110**. The angular difference between steering angle
15 δ and swing angle γ may be due to the distance between the steering pivot point and the pivot point of CV joint **110**, and/or due to the difference in placement of the swing axis on which the drive shaft swings, relative to the placement of the steering axis on which the wheel-hub, or wheel, is steered.

In some embodiments, the ratio between swing angle γ and steering angle δ is at not
20 greater than 1:1.25, 1:1.5, 1:2, 1:2.5, or 1:3. In some example embodiments, when steering angle δ is about 25-35 deg, the swing angle γ is about 15-25 deg.

Reference is now made to Fig. 11, which is a schematic flow chart of a method for enabling transfer of propelling torque from a motion actuator of a vehicle to a wheel of a vehicle, using the wheel drive assembly of the disclosed technology, according to some
25 embodiments thereof.

As seen in Fig. 11, at step **200** an outer CV joint, such as CV joint **110** (Fig. 3) of a drive shaft, such as drive shaft **105** (Fig. 3) is fastened to an outer side of a wheel-hub, such as wheel-hub **102** (Fig. 3). Following the fastening, an outermost surface of the outer CV joint is disposed outwardly of an outermost surface of the wheel-hub.

30 At step **202**, an inner CV joint of the drive shaft, such as inner CV joint **108** (Fig. 3) is connected to an output shaft of a motion actuator, such as an output shaft of a motor or drivetrain. In some embodiments, such as the embodiment shown in Fig. 9, connecting of the

inner CV joint comprises connecting the inner CV joint to the motion actuator at an exterior edge of a chassis onto which the motion actuator is fixed.

At step **204**, a wheel is mounted onto the wheel hub. As such, when the motion actuator is operated, the drive shaft **105** transfers propelling torque from the motion actuator to the wheel-hub and the wheel. In some embodiments, mounting of the wheel comprises fastening the tire rim of the wheel to the wheel hub.

In some embodiments, step **204** occurs prior to step **200** and/or prior to step **202**.

In some embodiments, at step **208**, which occurs prior to steps **200** and **202**, the outer CV joint is inserted into the wheel hub from an exterior side of the wheel hub. In some such embodiments, the inner CV joint is slid into an opening in the wheel-hub, from an outer side of the wheel-hub, and is moved in an inward direction, until the outer CV joint engages a surface of the wheel hub. Specifically, the inner CV joint may be moved until the outer CV joint is accommodated in an outer-side seat of the wheel-hub.

It is expected that during the life of a patent maturing from this application many relevant brake actuators and brake-control-circuits will be developed. The scope of the terms brake actuators and brake-control-circuits are intended to include all such new technologies, a priori.

It is appreciated that certain features of the invention, which are, for clarity, described in the context of separate embodiments, may also be provided in combination in a single embodiment. Conversely, various features of the invention, which are, for brevity, described in the context of a single embodiment, may also be provided separately or in any suitable subcombination or as suitable in any other described embodiment of the invention. Certain features described in the context of various embodiments are not to be considered essential features of those embodiments, unless the embodiment is inoperative without those elements. Although the invention has been described in conjunction with specific embodiments thereof, it is evident that many alternatives, modifications and variations will be apparent to those skilled in the art. Accordingly, it is intended to embrace all such alternatives, modifications and variations that fall within the spirit and broad scope of the appended claims.

30

WHAT IS CLAIMED IS:

1. A wheel drive assembly for transferring propelling torque from a source shaft to a wheel, the source shaft receiving torque from a motion actuator, the wheel drive assembly comprising:
 - a) a wheel-hub, adapted to have the wheel mounted thereon, the wheel-hub being arranged about a longitudinal axis, which is adapted to coincide with a rotation axis of the wheel;
 - b) a drive axle; and
 - c) a constant velocity (CV) joint mounted onto an outer end of the drive axle, the CV joint connecting the drive axle to the wheel-hub,
wherein an outermost surface of the CV joint is disposed outwardly of an outermost surface of the wheel hub, along the longitudinal axis of the wheel-hub.
2. The wheel drive assembly of claim 1, wherein the drive axle comprises a half shaft.
3. The wheel drive assembly of claim 1 or claim 2, wherein the CV joint comprises a housing and a cage accommodated within the housing.
4. The wheel drive assembly of claim 3, wherein the wheel-hub includes a seat at an outer side thereof, and wherein the housing engages the seat.
5. The wheel drive assembly of claim 3, wherein the housing engages the wheel-hub from an outer side of the wheel-hub.
6. The wheel drive assembly of any one of claims 3 to 5, wherein the housing is separable from the wheel hub.
7. The wheel drive assembly of any one of claims 3 to 6, wherein, in use of the CV joint, bearings of the CV joint are adapted rotate about an interior surface of the housing.
8. The wheel drive assembly of any one of the preceding claims, wherein a majority of the CV joint is exposed exteriorly to the wheel hub.
9. The wheel drive assembly of any one of the preceding claims, further comprising an inner CV joint mounted onto an inner end of the drive axle, and adapted to be functionally coupled to the source shaft.
10. A wheel assembly, comprising:
 - a wheel drive assembly according to any one of claims 1 to 9; and
 - a wheel including a tire and a tire rim, the tire rim mounted onto the wheel-hub, wherein at least a portion of the CV joint is visible from an outer side of the wheel.

11. The wheel assembly of claim 10, further comprising a disk brake and caliper, wherein at least a portion of the CV joint is exterior to the disk brake.
12. The wheel assembly of claim 10 or claim 11, wherein an outermost surface of the cv joint extends outwardly of a central portion of the tire rim.
13. The wheel assembly of any one of claims 10 to 12, wherein the outermost surface of the CV joint extends outwardly of the majority of the tire rim.
14. The wheel assembly of any one of claims 10 to 13, wherein the outermost surface of the CV joint extends outwardly of the entirety of the tire rim.
15. The wheel assembly of any one of claims 10 to 14, further comprising, or functionally associated with, a steering assembly adapted to steer the wheel hub about a steering pivot point, wherein the steering pivot point does not coincide with a pivot point of the CV joint.
16. The wheel assembly of claim 15, wherein, when the steering assembly steers the wheel hub at a steering angle δ , the CV joint swings at a swing angle γ , swing angle γ being smaller than steering angle δ .
17. The wheel assembly of claim 16, wherein a ratio between swing angle γ and steering angle δ is not greater than 1:1.5.
18. A vehicle, comprising:
 - a chassis;
 - at least one motion actuator, functionally associated with the chassis, the motion actuator having an output shaft; and
 - at least one wheel assembly according to any one of claims 10 to 17, wherein the wheel drive assembly of the at least one wheel assembly is functionally associated with the output shaft of the motion actuator, as the source shaft, and the at least one wheel assembly is adapted to transfer propelling torque from the at least one motion actuator to the wheel of the at least one wheel assembly.
19. The vehicle of claim 18, wherein the wheel drive assembly further comprises an inner CV joint mounted onto an inner end of the drive axle, the inner CV joint being functionally coupled to the output shaft of the motion actuator.
20. The vehicle of claim 19, wherein the inner CV joint is disposed at a laterally exterior edge of the chassis.

21. The vehicle of claim 19 or claim 20, wherein the inner CV joint is vertically stationary with respect to the chassis, and the outer CV joint is vertically movable with respect to the chassis, within a predetermined angular range of the drive axle relative to the chassis.
22. The vehicle of any one of claims 19 to 21, wherein the motion actuator is attached to the chassis, and functions as a sprung mass.
23. A vehicle, comprising:
a chassis;
at least one motion actuator, functionally associated with the chassis, the motion actuator having an output shaft; and
at least one wheel assembly, including:
a wheel-hub arranged about a longitudinal axis;
a drive axle;
a constant velocity (CV) joint mounted onto an outer end of the drive axle, the CV joint connecting the drive axle to the wheel-hub; and
a wheel including a tire and a tire rim, the tire rim mounted onto the wheel-hub such that the longitudinal axis of the wheel-hub coincides with a rotational axis of the wheel,
the wheel assembly being functionally associated with the output shaft of the motion actuator, as the source shaft, and the drive axle and CV joint are adapted to transfer propelling torque from the at least one motion actuator to the wheel; and
a steering assembly, functionally associated with the wheel-hub and adapted to steer the wheel by pivoting the wheel-hub and the wheel about a steering pivot point, wherein the steering pivot point does not coincide with a pivot point of the CV joint.
24. The vehicle of claim 23, wherein, when the steering assembly steers the wheel hub at a steering angle δ , the CV joint swings at a swing angle γ , swing angle γ being smaller than steering angle δ .
25. A vehicle, comprising:
a chassis;
at least one motion actuator, functionally associated with the chassis, the motion actuator having an output shaft; and
at least one wheel assembly, including:

- a wheel-hub arranged about a longitudinal axis;
a drive axle;
a constant velocity (CV) joint mounted onto an outer end of the drive axle, the CV joint connecting the drive axle to the wheel-hub; and
a wheel including a tire and a tire rim, the tire rim mounted onto the wheel-hub,
the wheel assembly being functionally associated with the output shaft of the motion actuator, as the source shaft, and the drive axle and CV joint are adapted to transfer propelling torque from the at least one motion actuator to the wheel; and
a steering assembly, functionally associated with the wheel-hub and adapted to steer the wheel by pivoting the wheel-hub and the wheel about a steering pivot point, wherein the steering pivot point does not coincide with a pivot point of the CV joint,
wherein, when the steering assembly steers the wheel hub at a steering angle δ , the CV joint swings at a swing angle γ , swing angle γ being smaller than steering angle δ .
26. The vehicle of claim 24 or claim 25, wherein a ratio between swing angle γ and steering angle δ is not greater than 1:1.5.
27. The vehicle of any one of claims 23 to 26, wherein an outermost surface of the CV joint is disposed outwardly of an outermost surface of the wheel hub, along the longitudinal axis of the wheel-hub.
28. The vehicle of any one of claims 23 to 27, wherein at least a portion of the CV joint is visible from an outer side of the wheel.
29. The vehicle of any one of claims 23 to 28, wherein the wheel drive assembly further comprises an inner CV joint mounted onto an inner end of the drive axle, the inner CV joint being functionally coupled to the output shaft of the motion actuator.
30. The vehicle of claim 29, wherein the inner CV joint is disposed at a laterally exterior edge of the chassis.
31. The vehicle of claim 29 or claim 30, wherein the inner CV joint is vertically stationary with respect to the chassis, and the outer CV joint is vertically movable with respect to the chassis, within a predetermined angular range of the drive axle relative to the chassis.
32. The vehicle of any one of claims 23 to 31, wherein the motion actuator is attached to the chassis, and functions as a sprung mass.

33. A method for enabling transfer of propelling torque from a motion actuator of a vehicle, having an output shaft, to a wheel of the vehicle, using a drive shaft, the method comprising:

fastening an outer CV joint of the drive shaft to an outer side of the wheel-hub;
connecting an inner CV joint of the drive shaft to the output shaft of the motion actuator; and

mounting a wheel on the wheel hub,

wherein, following the fastening, an outermost surface of the CV joint is disposed outwardly of an outermost surface of the wheel hub.

34. The method of claim 33, the mounting of the wheel on the wheel hub occurs prior to the fastening of the outer CV joint.

35. The method of any one of claims 33 to 34, further comprising, prior to the fastening, inserting the outer CV joint into the wheel hub from an exterior side of the wheel hub.

36. The method of claim 35, wherein the wheel-hub includes an outer-side seat, and the inserting of the outer CV joint comprises accommodating the outer CV joint in the outer-side seat.

37. The method of any one of claims 33 to 36, wherein the wheel comprises a tire mounted onto a tire rim, and the mounting of the wheel on the wheel hub comprises fastening the tire rim to the wheel-hub.

38. The method of claim 37, wherein the outermost surface of the outer CV joint extends outwardly of a central portion of the tire rim.

39. The method of claim 37 or claim 38, wherein the outermost surface of the outer CV joint extends outwardly of the majority of the tire rim.

40. The method of any one of claims 37 to 39, wherein the outermost surface of the outer CV joint extends outwardly of the entirety of the tire rim.

41. The method of claims 33 to 40, wherein the connecting an inner CV joint comprises placing the inner CV joint at an exterior edge of a chassis of the vehicle.

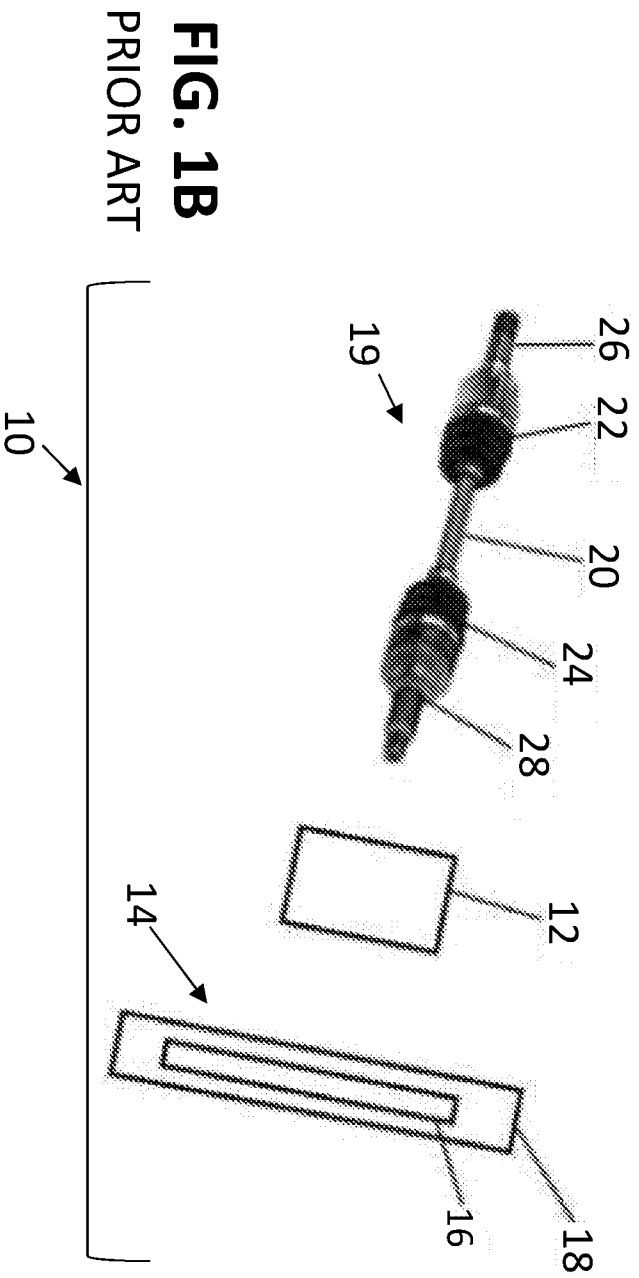
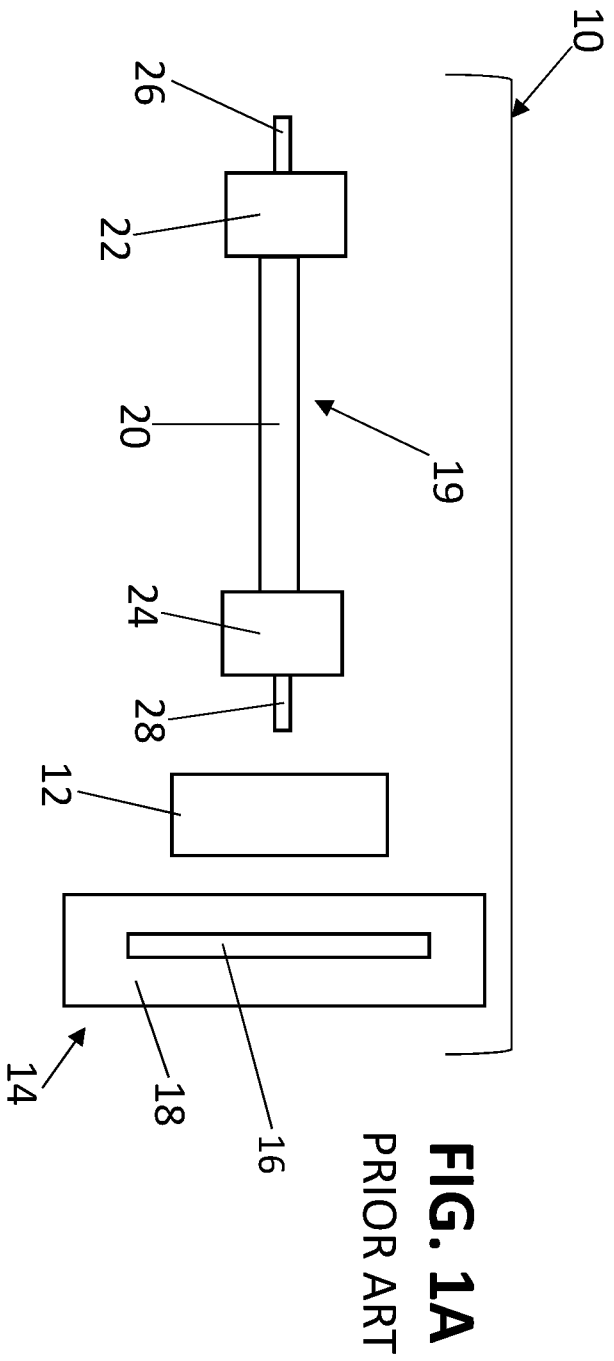

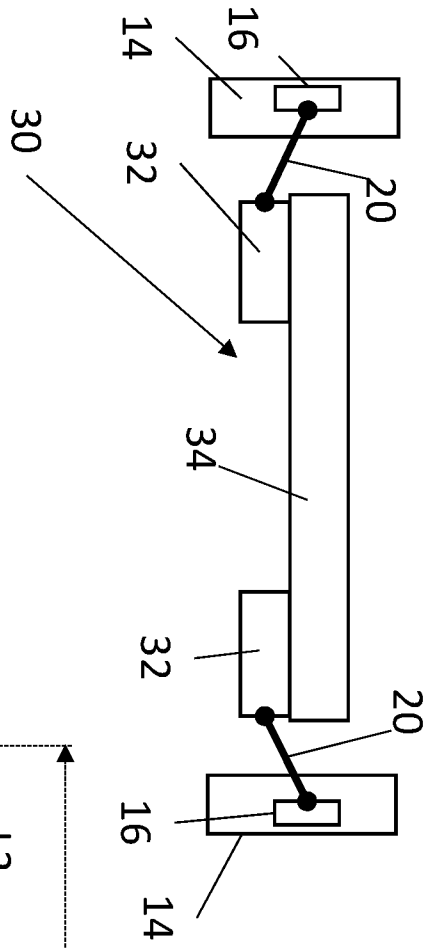

FIG. 1C
PRIOR ART

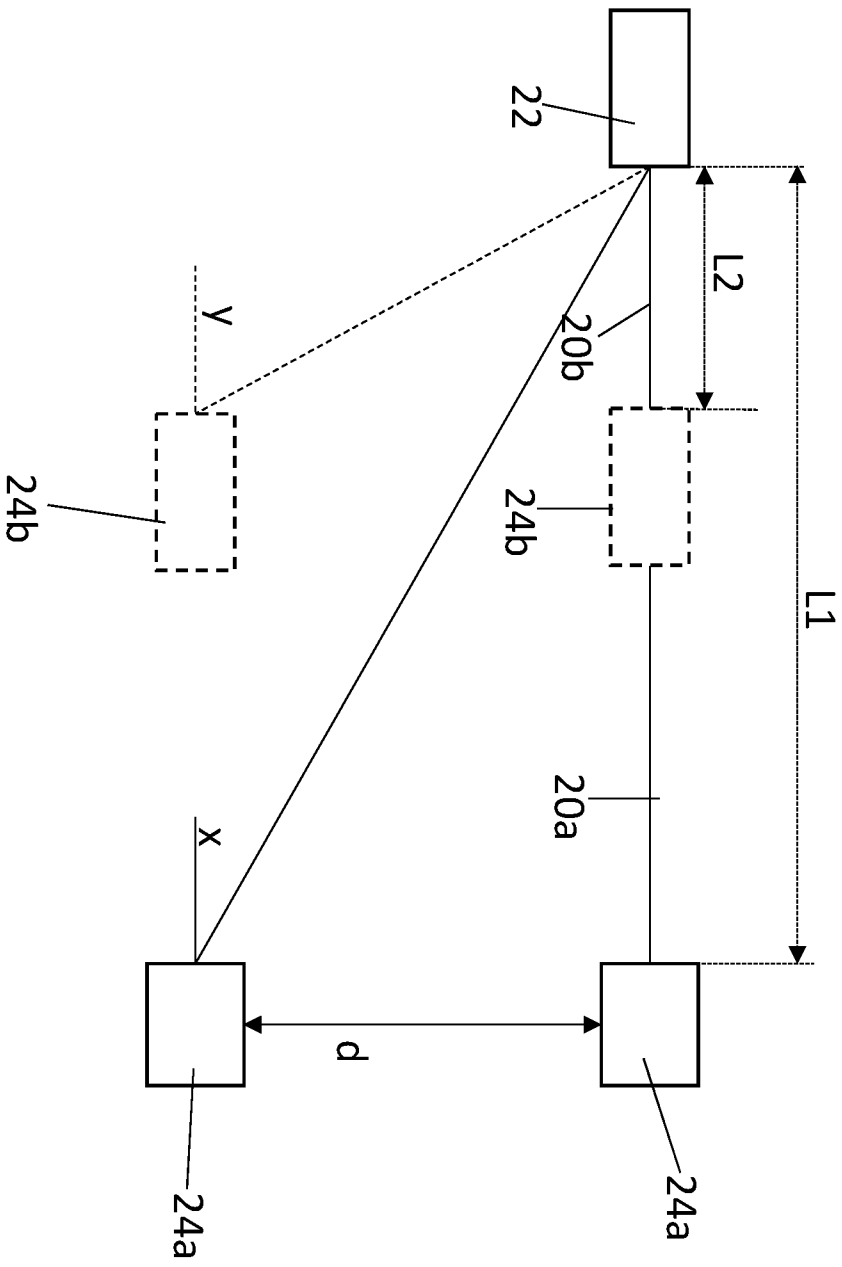

FIG. 2
PRIOR ART

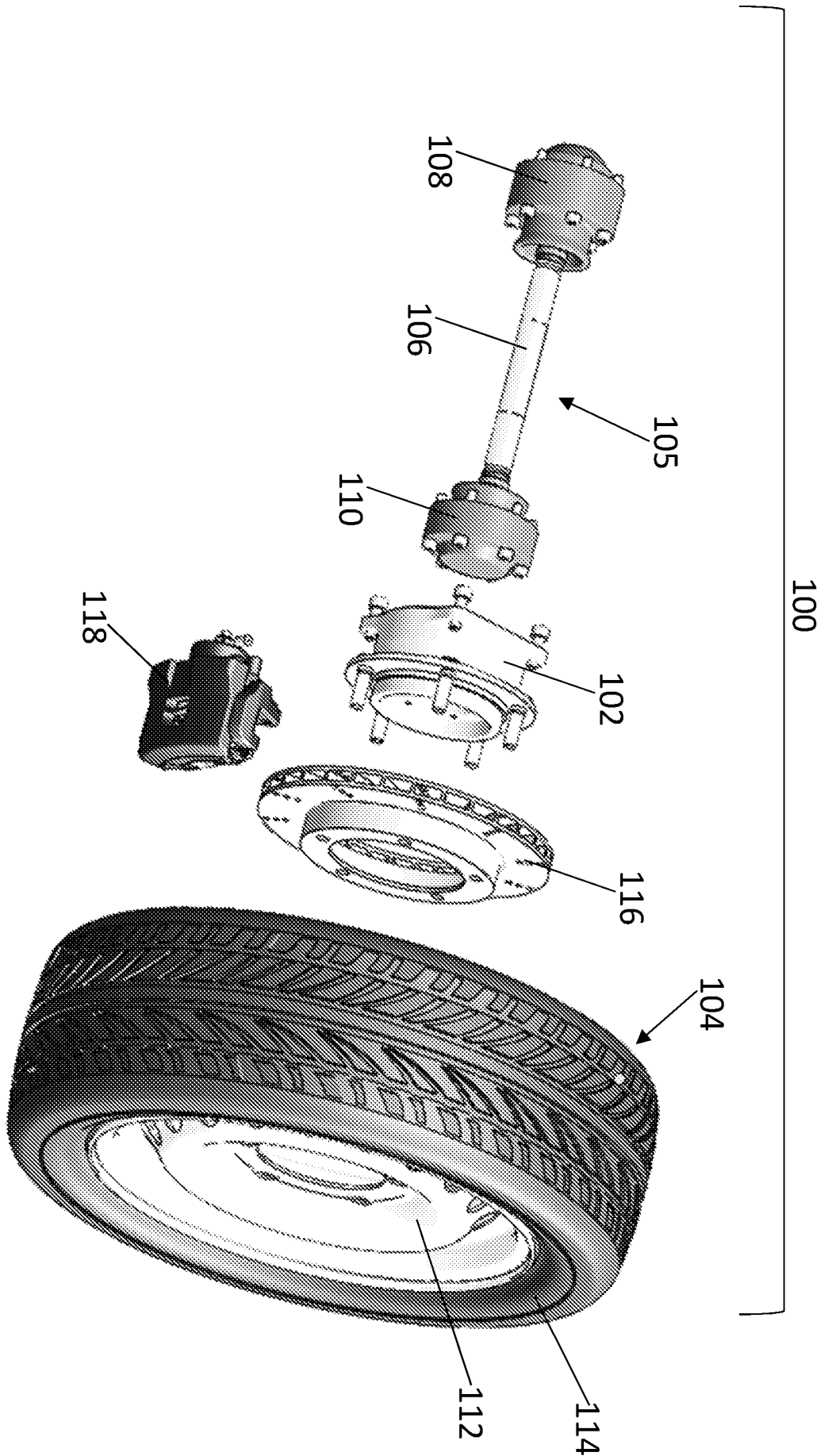

FIG. 3

FIG. 4A

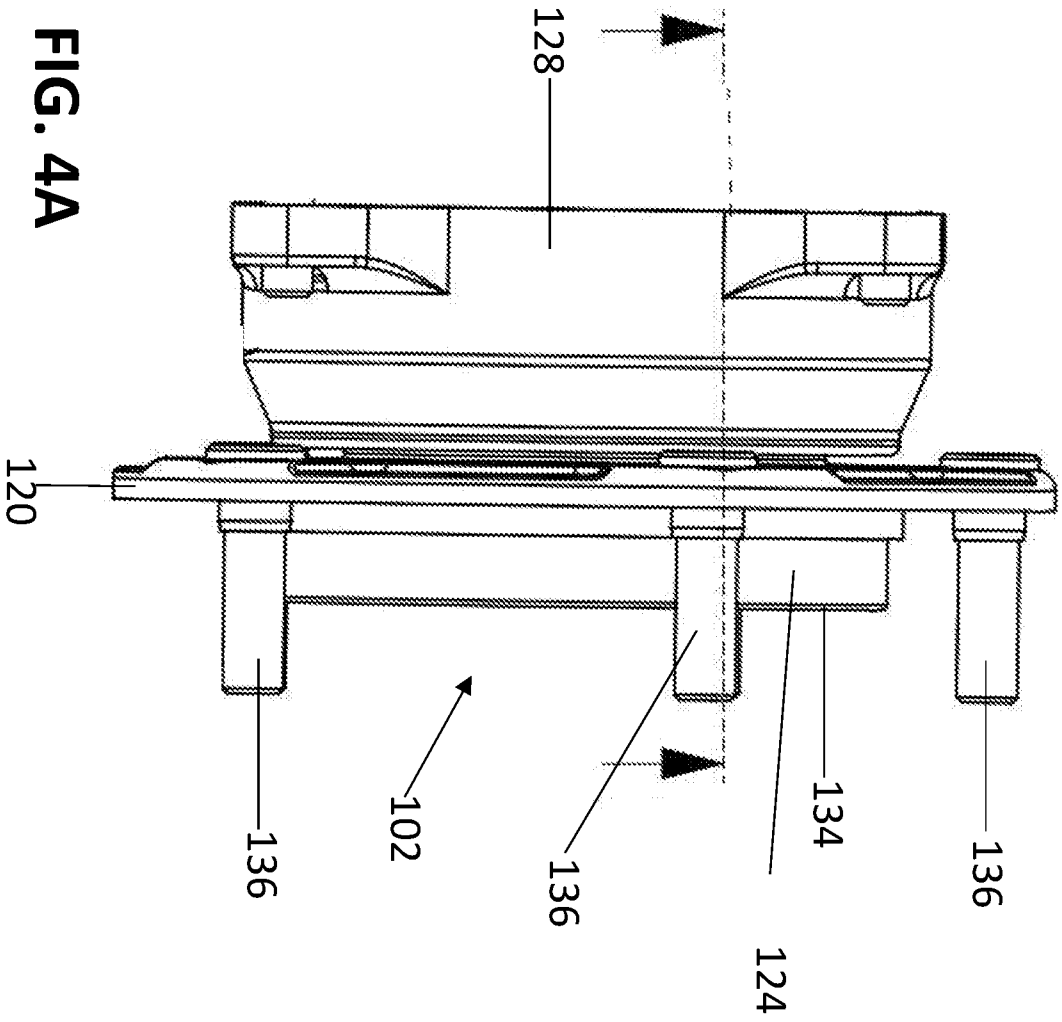
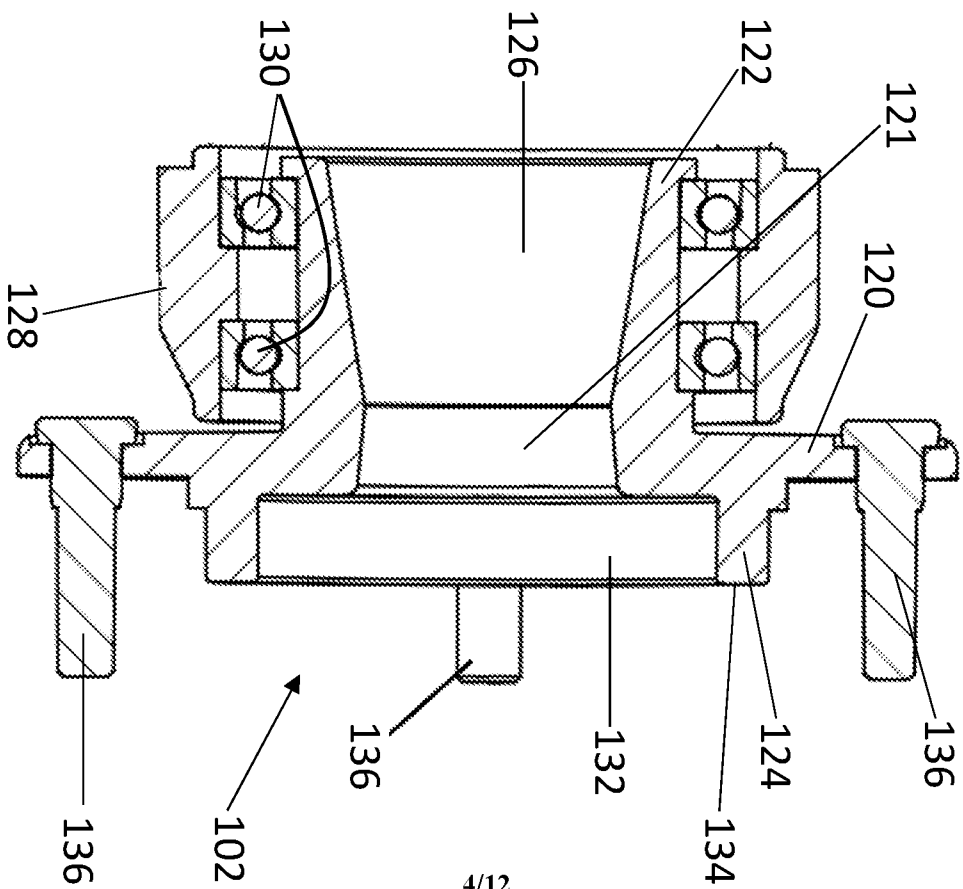

FIG. 4B



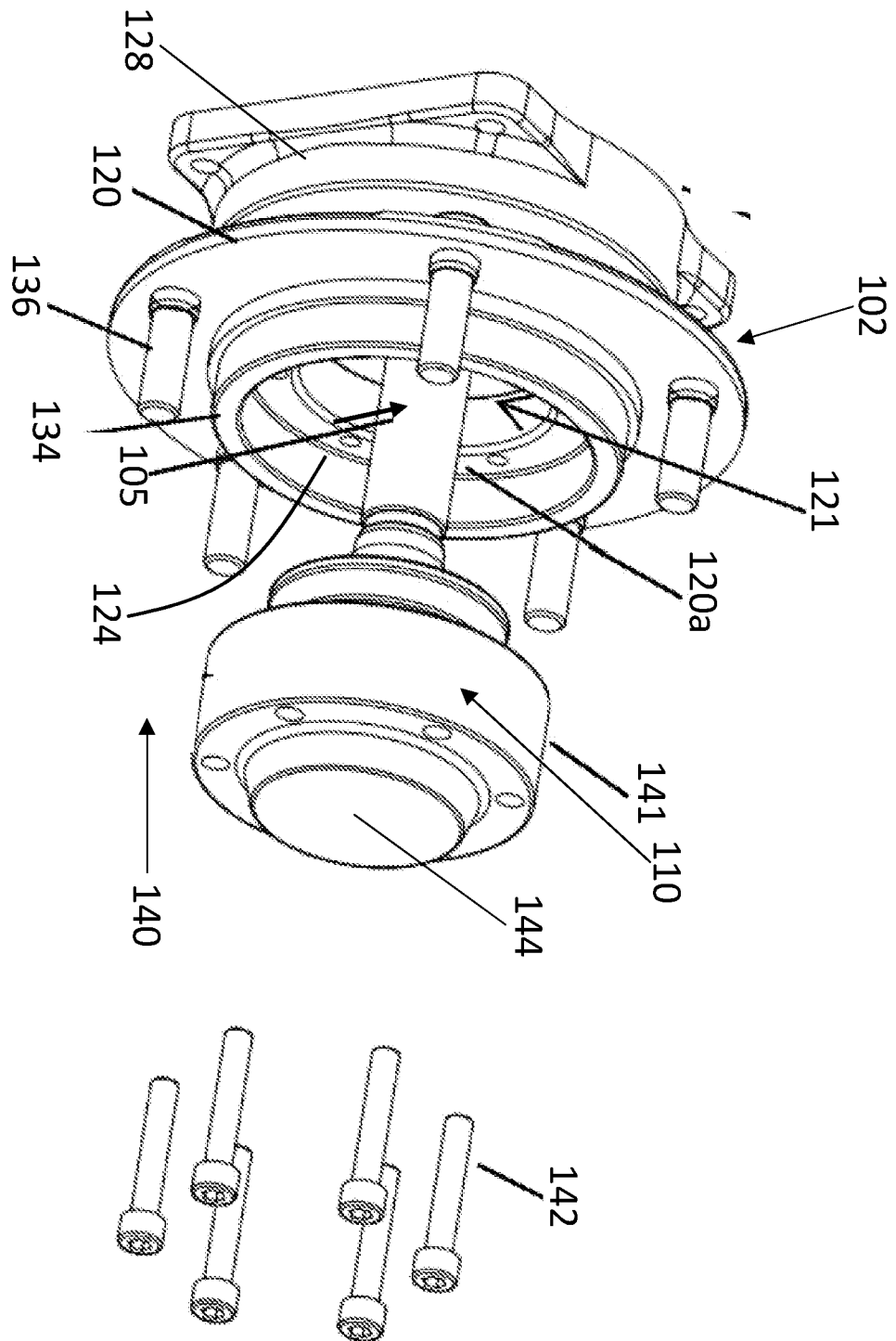

FIG. 5

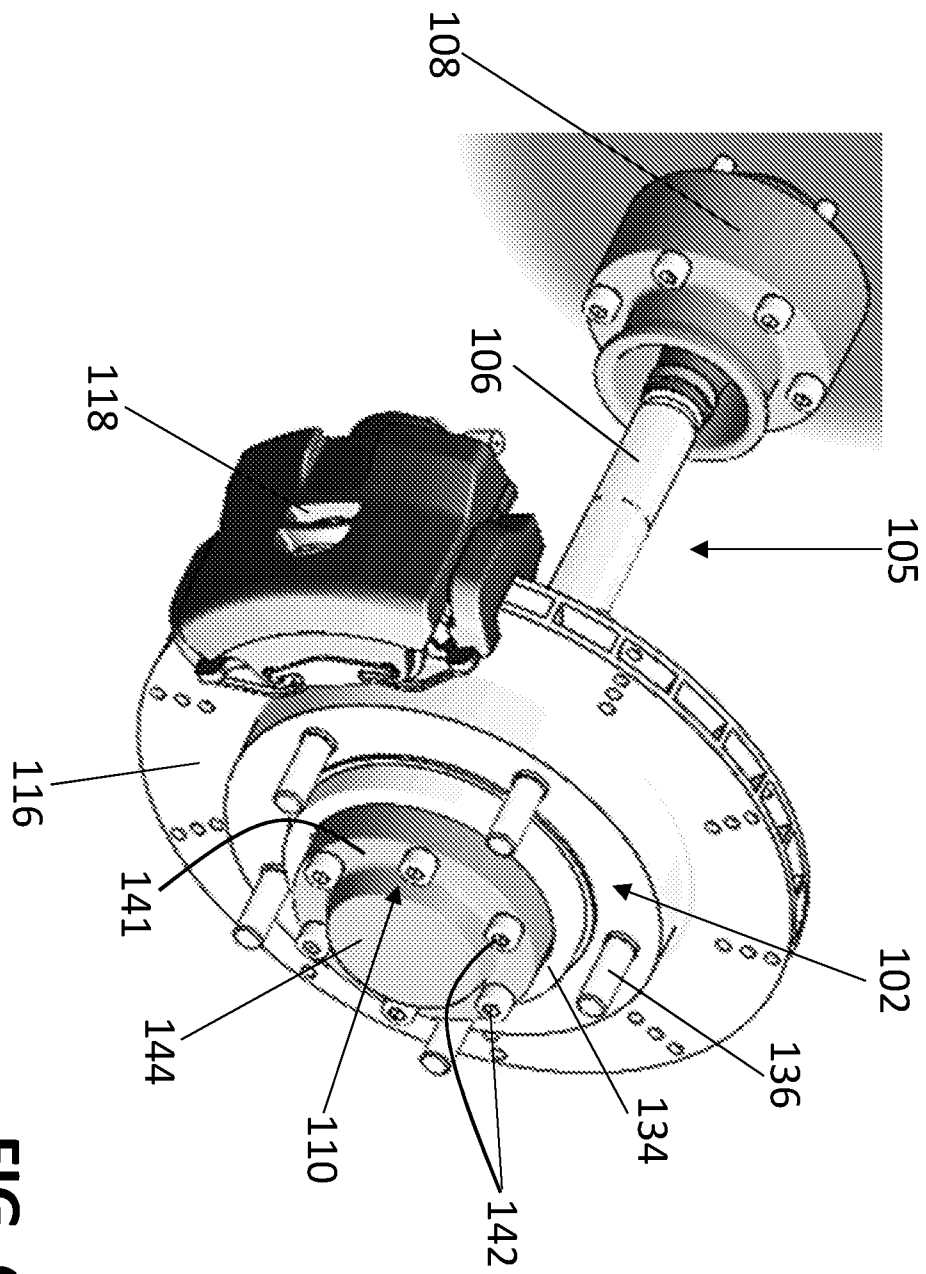

FIG. 6A

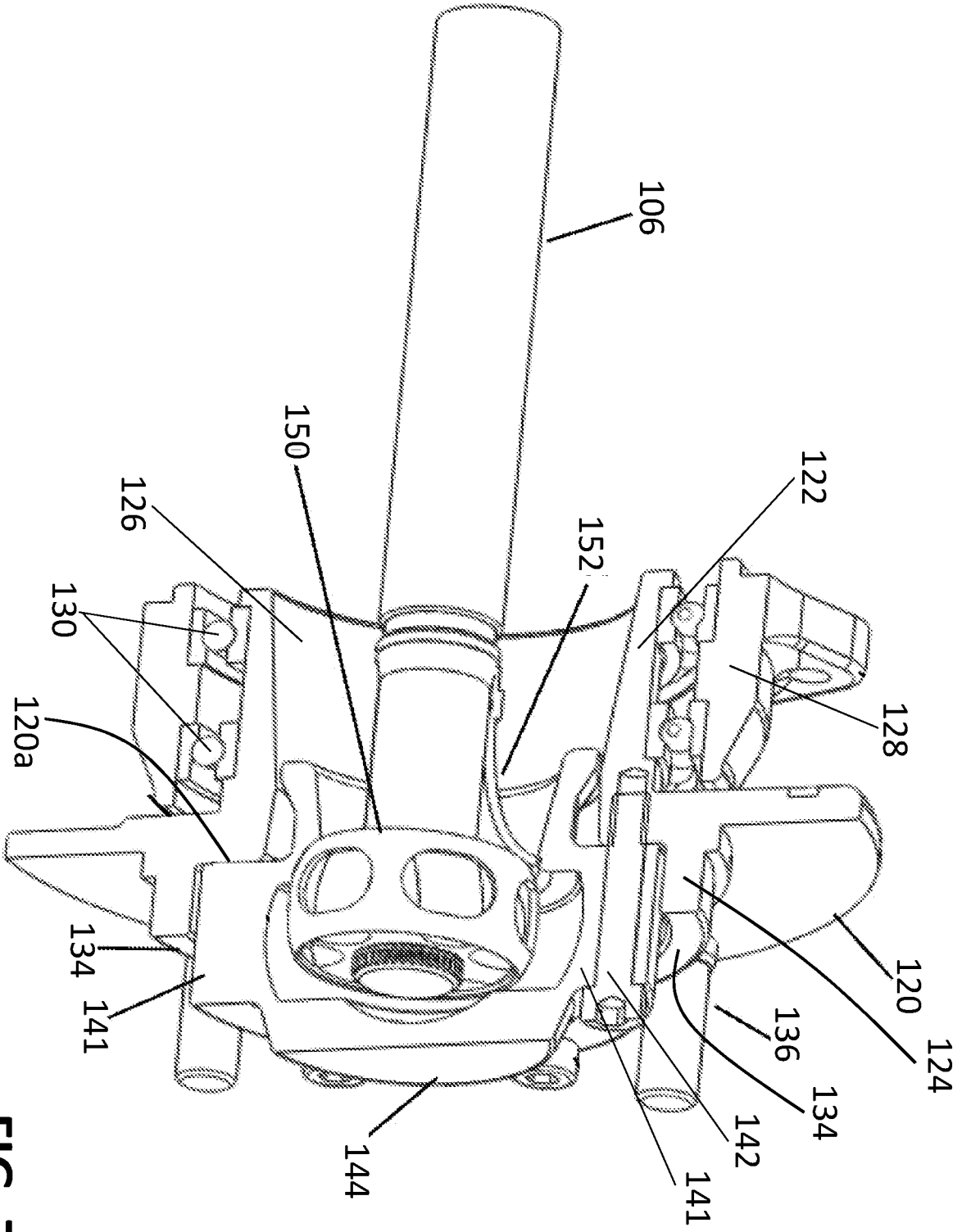

FIG. 7

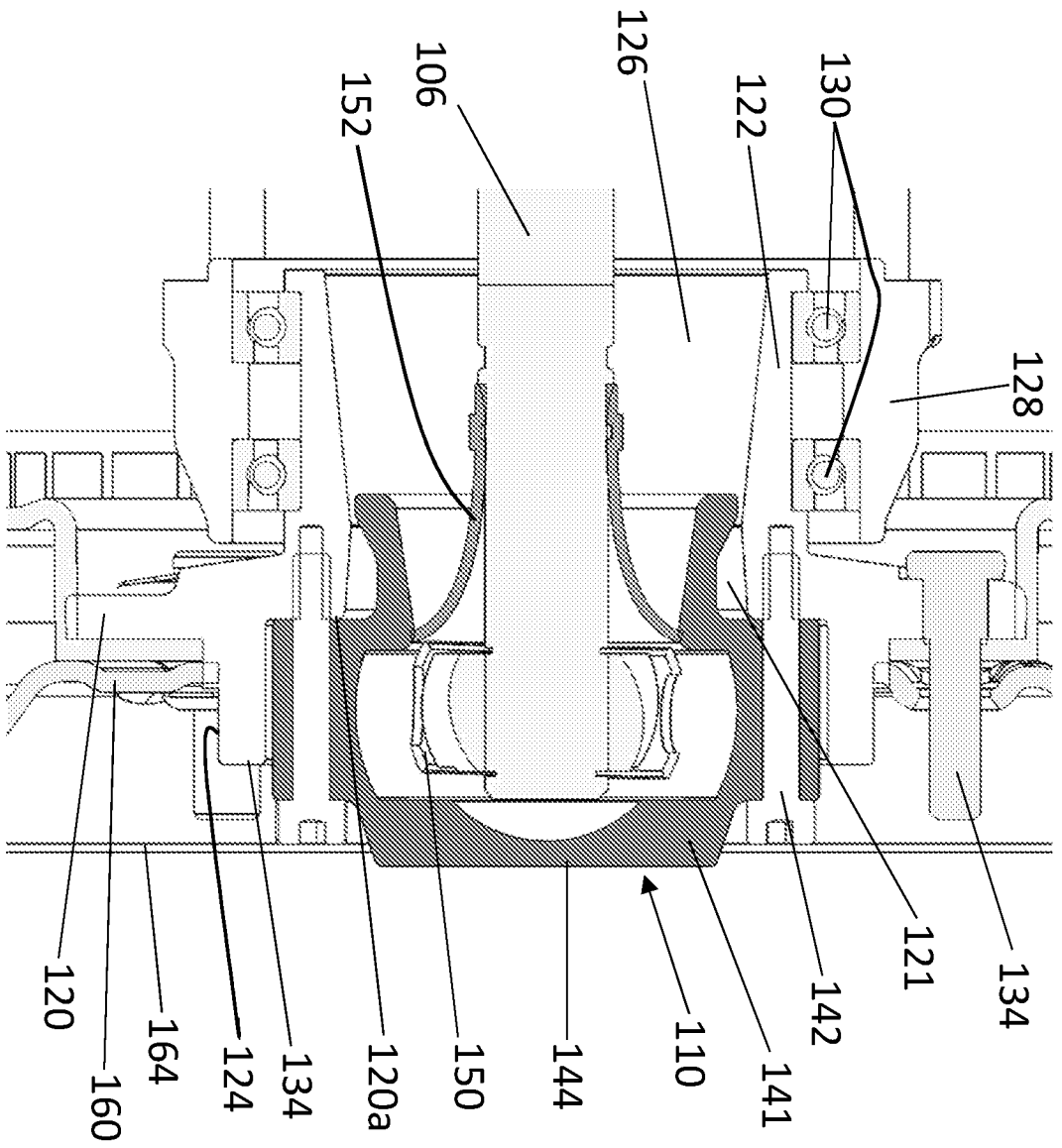

FIG. 8A

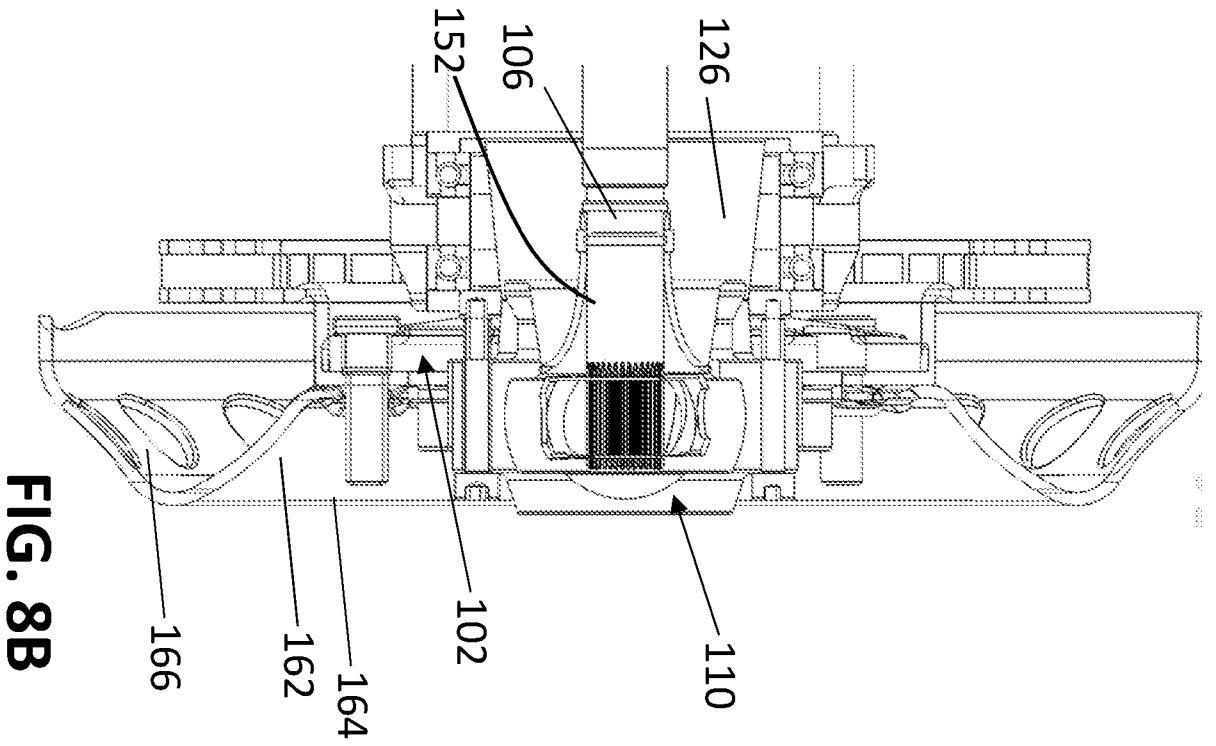

FIG. 8B

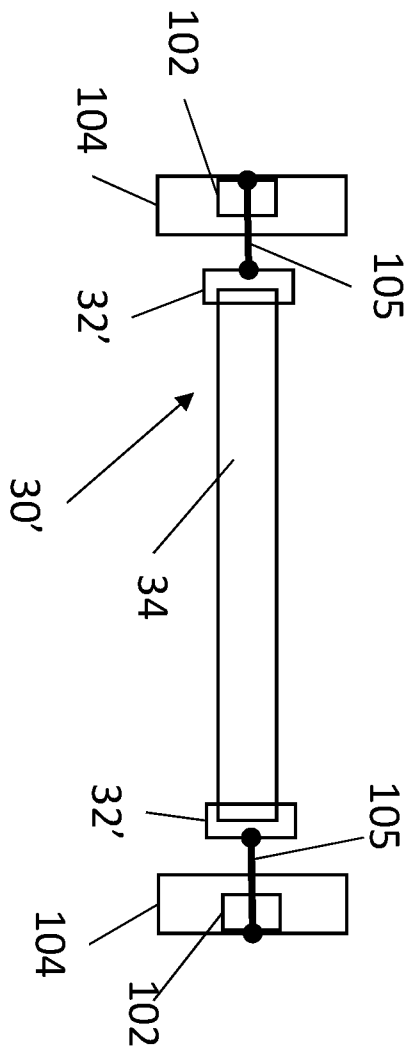

FIG. 9

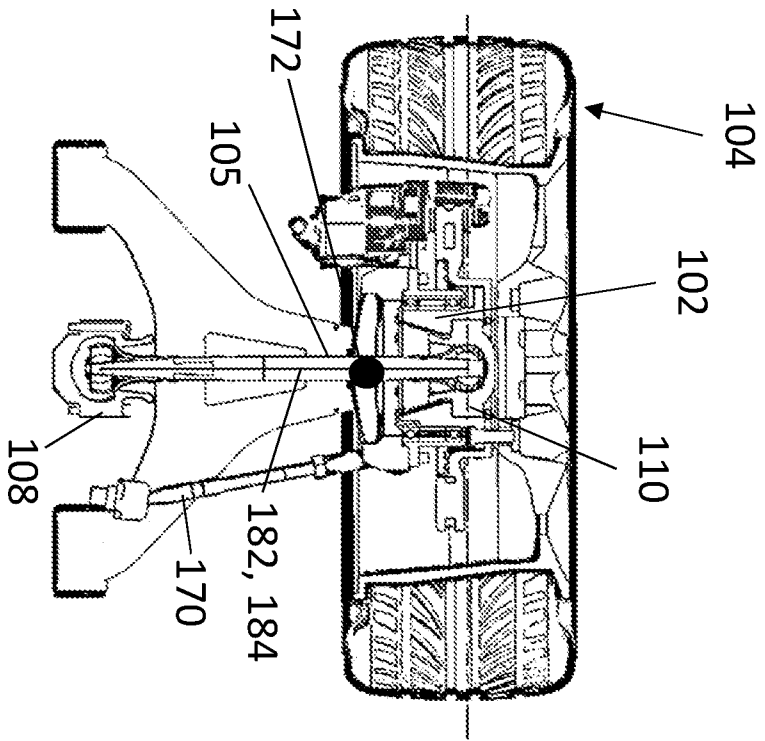

FIG. 10A

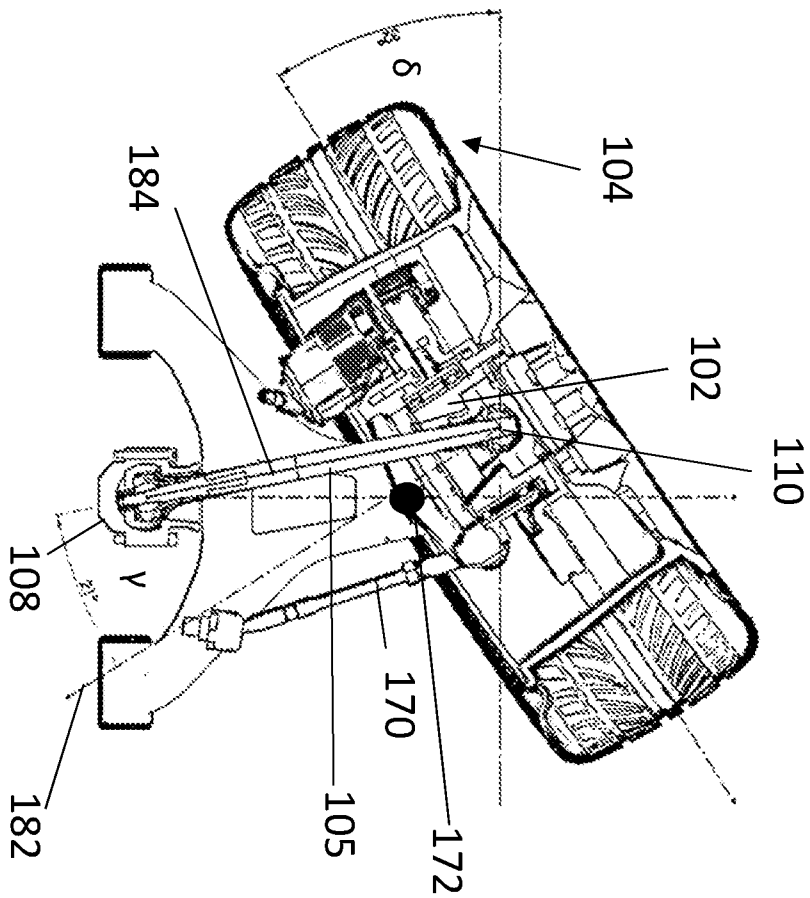
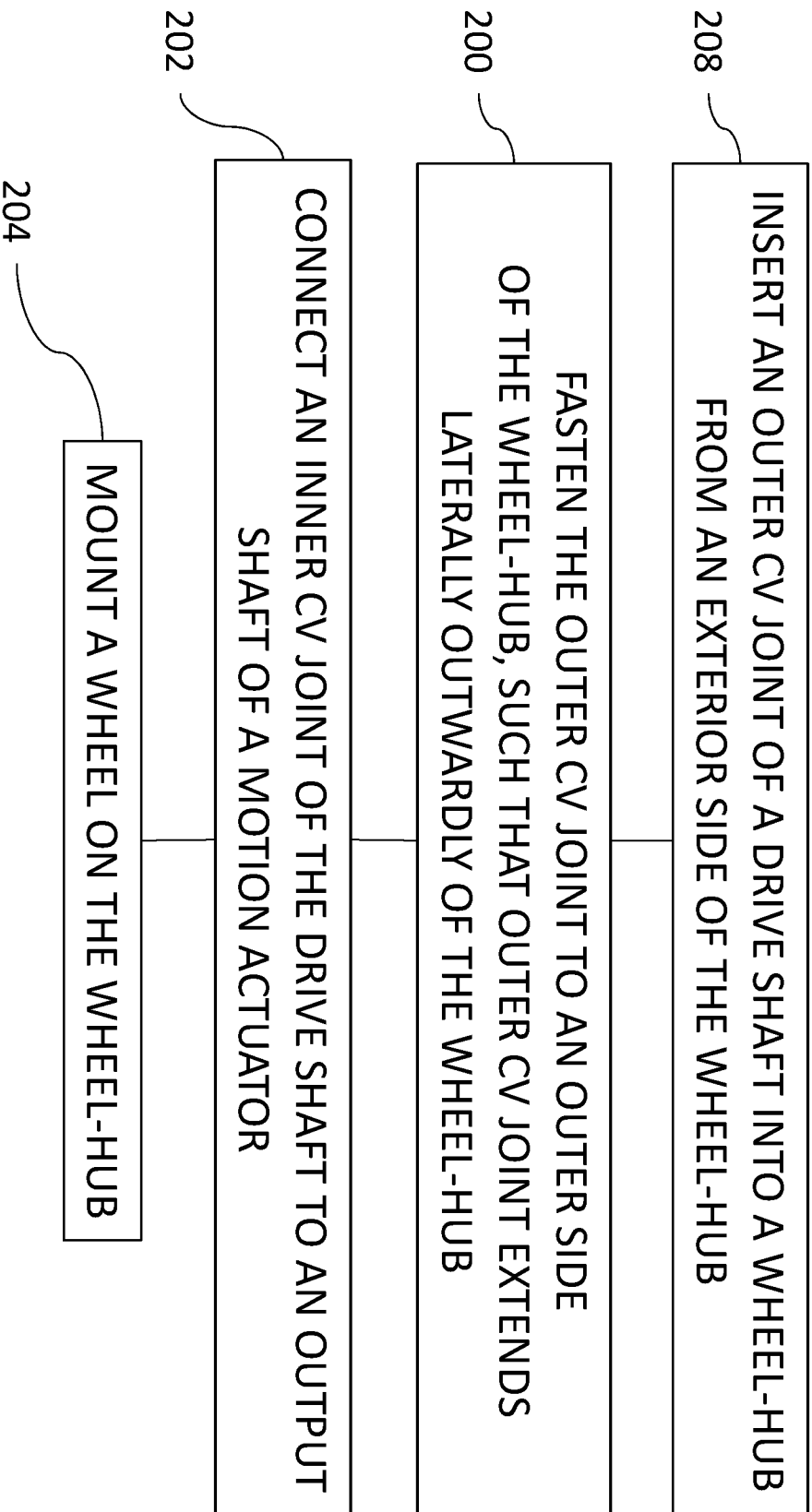

FIG. 10B

**FIG. 11**

INTERNATIONAL SEARCH REPORT

International application No.

PCT/IB2021/057921

<p>A. CLASSIFICATION OF SUBJECT MATTER IPC (20210101) B60B 27/00, B60B 35/18, B60K 1/04 CPC (20130101) B60B 27/0042, B60B 35/18, B60B 27/0078, B60K 1/04 According to International Patent Classification (IPC) or to both national classification and IPC</p>																				
<p>B. FIELDS SEARCHED</p> <p>Minimum documentation searched (classification system followed by classification symbols) IPC (20210101) B60B 27/00, B60B 35/18 CPC (20130101) B60B 27/0042, B60B 35/18, B60B 27/0078</p> <p>Documentation searched other than minimum documentation to the extent that such documents are included in the fields searched</p> <p>Electronic data base consulted during the international search (name of data base and, where practicable, search terms used) Databases consulted: Google Patents, Orbit, Similari (AI-based)</p>																				
<p>C. DOCUMENTS CONSIDERED TO BE RELEVANT</p> <table border="1"> <thead> <tr> <th>Category*</th> <th>Citation of document, with indication, where appropriate, of the relevant passages</th> <th>Relevant to claim No.</th> </tr> </thead> <tbody> <tr> <td>X</td> <td>US 4300651 A UNI CARDAN AG [DE] 17 Nov 1981 (1981/11/17) Entire document</td> <td>1-7,9-11,19-22, 33-41</td> </tr> <tr> <td>X</td> <td>US 2547435 A ROBERT BOUCHARD [FR] 03 Apr 1951 (1951/04/03) Entire document</td> <td>1,8,10,12-17,23-32</td> </tr> <tr> <td>A</td> <td>KR 20180043966 A HYUNDAI WIA CORP [KR] 02 May 2018 (2018/05/02) Entire document</td> <td>1-41</td> </tr> <tr> <td>A</td> <td>JP 3905281 B2 KOYO SEIKO CO LTD [JP] 18 Apr 2007 (2007/04/18) Entire document</td> <td>1-41</td> </tr> <tr> <td>A</td> <td>US 4473129 A GLAENZER SPICER SA [FR] 25 Sep 1984 (1984/09/25) Entire document</td> <td>1-41</td> </tr> </tbody> </table>			Category*	Citation of document, with indication, where appropriate, of the relevant passages	Relevant to claim No.	X	US 4300651 A UNI CARDAN AG [DE] 17 Nov 1981 (1981/11/17) Entire document	1-7,9-11,19-22, 33-41	X	US 2547435 A ROBERT BOUCHARD [FR] 03 Apr 1951 (1951/04/03) Entire document	1,8,10,12-17,23-32	A	KR 20180043966 A HYUNDAI WIA CORP [KR] 02 May 2018 (2018/05/02) Entire document	1-41	A	JP 3905281 B2 KOYO SEIKO CO LTD [JP] 18 Apr 2007 (2007/04/18) Entire document	1-41	A	US 4473129 A GLAENZER SPICER SA [FR] 25 Sep 1984 (1984/09/25) Entire document	1-41
Category*	Citation of document, with indication, where appropriate, of the relevant passages	Relevant to claim No.																		
X	US 4300651 A UNI CARDAN AG [DE] 17 Nov 1981 (1981/11/17) Entire document	1-7,9-11,19-22, 33-41																		
X	US 2547435 A ROBERT BOUCHARD [FR] 03 Apr 1951 (1951/04/03) Entire document	1,8,10,12-17,23-32																		
A	KR 20180043966 A HYUNDAI WIA CORP [KR] 02 May 2018 (2018/05/02) Entire document	1-41																		
A	JP 3905281 B2 KOYO SEIKO CO LTD [JP] 18 Apr 2007 (2007/04/18) Entire document	1-41																		
A	US 4473129 A GLAENZER SPICER SA [FR] 25 Sep 1984 (1984/09/25) Entire document	1-41																		
<p><input type="checkbox"/> Further documents are listed in the continuation of Box C. <input checked="" type="checkbox"/> See patent family annex.</p>																				
<p>* Special categories of cited documents:</p> <p>“A” document defining the general state of the art which is not considered to be of particular relevance</p> <p>“D” document cited by the applicant in the international application</p> <p>“E” earlier application or patent but published on or after the international filing date</p> <p>“L” document which may throw doubts on priority claim(s) or which is cited to establish the publication date of another citation or other special reason (as specified)</p> <p>“O” document referring to an oral disclosure, use, exhibition or other means</p> <p>“P” document published prior to the international filing date but later than the priority date claimed</p> <p>“T” later document published after the international filing date or priority date and not in conflict with the application but cited to understand the principle or theory underlying the invention</p> <p>“X” document of particular relevance; the claimed invention cannot be considered novel or cannot be considered to involve an inventive step when the document is taken alone</p> <p>“Y” document of particular relevance; the claimed invention cannot be considered to involve an inventive step when the document is combined with one or more other such documents, such combination being obvious to a person skilled in the art</p> <p>“&” document member of the same patent family</p>																				
<p>Date of the actual completion of the international search 09 Dec 2021</p>		<p>Date of mailing of the international search report 16 Dec 2021</p>																		
<p>Name and mailing address of the ISA: Israel Patent Office Technology Park, Bldg.5, Malcha, Jerusalem, 9695101, Israel Email address: pctoffice@justice.gov.il</p>		<p>Authorized officer ORGAD Yaniv Telephone No. 972-73-3927151</p>																		

INTERNATIONAL SEARCH REPORT
Information on patent family members

International application No.
PCT/IB2021/057921

Patent document cited search report			Publication date	Patent family member(s)			Publication Date
US	4300651	A	17 Nov 1981	US	4300651	A	17 Nov 1981
<hr/>							
				DE	2903231	A1	31 Jul 1980
				DE	2903231	C2	30 Jul 1987
				FR	2447284	A1	22 Aug 1980
				FR	2447284	B1	13 Feb 1987
				GB	2041156	A	03 Sep 1980
				GB	2041156	B	09 Mar 1983
				IT	8005102	D0	03 Jan 1980
				IT	1195896	B	27 Oct 1988
				IT	8006902	V0	03 Jan 1980
				JP	S55102723	A	06 Aug 1980
				JP	S6026728	B2	25 Jun 1985
US	2547435	A	03 Apr 1951	US	2547435	A	03 Apr 1951
<hr/>							
KR	20180043966	A	02 May 2018	KR	20180043966	A	02 May 2018
<hr/>							
				KR	101871992	B1	27 Jun 2018
JP	3905281	B2	18 Apr 2007	JP	2001233008	A	28 Aug 2001
<hr/>							
				JP	3905281	B2	18 Apr 2007
US	4473129	A	25 Sep 1984	US	4473129	A	25 Sep 1984
<hr/>							
				DE	3134913	A1	15 Apr 1982
				DE	3134913	C2	27 Sep 1984
				FR	2490157	A1	19 Mar 1982
				FR	2490157	B1	28 Dec 1984
				GB	2083785	A	31 Mar 1982
				GB	2083785	B	25 Jan 1984
				JP	S5780905	A	20 May 1982