

(No Model.)

P. YORKE.  
ROPE CLAMP.

No. 448,902.

Patented Mar. 24, 1891.

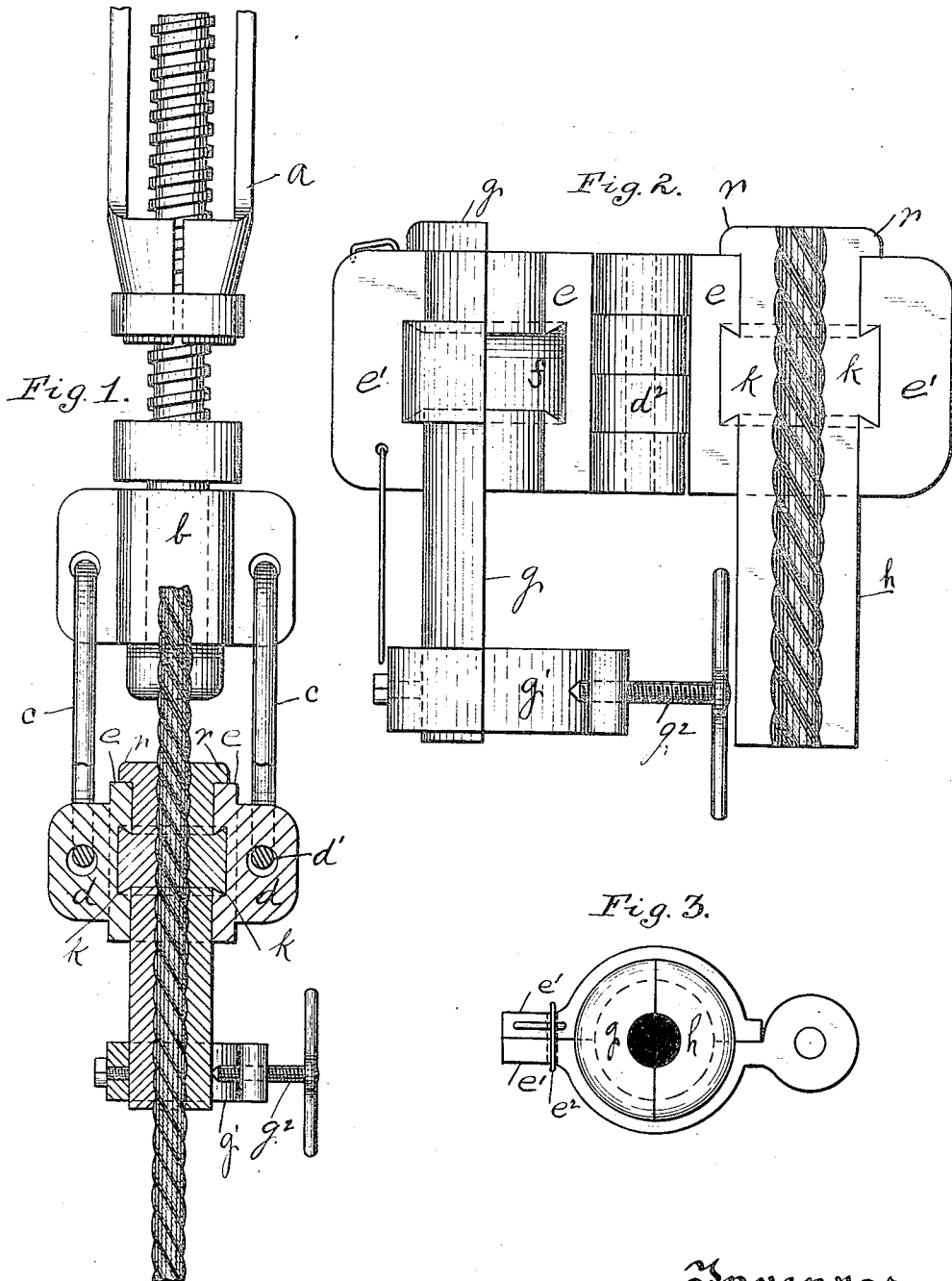

Witnesses:  
J. N. Coory,  
Robt. D. Jatten

Inventor:  
Patrick Yorke  
By James D. Kay  
Attorney

# UNITED STATES PATENT OFFICE.

PATRICK YORKE, OF WASHINGTON, PENNSYLVANIA.

## ROPE-CLAMP.

SPECIFICATION forming part of Letters Patent No. 448,902, dated March 24, 1891.

Application filed August 11, 1890. Serial No. 361,727. (No model.)

*To all whom it may concern:*

Be it known that I, PATRICK YORKE, a resident of Washington, in the county of Washington and State of Pennsylvania, have invented a new and useful Improvement in Rope-Clamps; and I do hereby declare the following to be a full, clear, and exact description thereof.

My invention relates to Artesian-well-drilling apparatus, and more especially to the clamps by which the rope is held in the drilling operation, my invention relating more particularly to clamps for wire rope and being an improvement on certain Letters Patent No. 392,627, granted to W. C. Mobley November 13, 1888. That patent relates to the suspension of the tools from the temper-screw, the temper-screw having a swivel at the base thereof, and suspended from said swivel a sleeve or collar, in which the rope-clamp is swiveled, so that the rope may be turned within the lower swivel without turning the upper swivel, means being thus provided for the operation of the wire or like rope by twisting or untwisting the strands thereof and overcoming the necessity of having the loose part of the rope wound around the part thereof extending from the clamps down into the well. In that patent two forms of collars for swiveling the rope-clamp are shown, the one being an open sleeve or collar having a slot in the side thereof, through which the clamping-pieces are inserted, and the other being a hinged collar adapted to be opened and closed around the clamping-pieces, which are thus swiveled within the collar. In such construction the clamping-faces were, as will be seen, free and separate from the collar, and when the collar was opened there was danger, especially of the smaller piece of the clamp which did not carry the clamping-screw, dropping into the well, the part being small and the ordinary driller being careless, so that there would be liability of such accident, which would require the fishing for the clamping-piece, and might possibly lead to the abandonment of the well.

The object of my invention is to provide a swiveling clamp for wire or like rope, in which the clamp can be turned within the sleeve, having free movement therein, but in which the clamping-pieces are firmly held within

the sleeve, so that all liability of the loss of the same is overcome, while at the same time a sleeve or collar can be employed which fits entirely around the clamping-pieces and so supports them more securely, and all necessity of the cutting away of any part of the clamping-pieces and the weakening thereof is overcome.

To these ends my invention consists, generally stated, in a sleeve or collar composed of two parts hinged together and having an annular dovetailed recess on its inner face and combined therewith clamping-pieces provided with like-shaped dovetailed projections adapted to enter the dovetailed recess of the sleeve or collar and so be held firmly therein when the sleeve or collar is opened to insert the rope.

The particular improvements embodying my invention and desired to be covered will be hereinafter set forth and claimed.

To enable others skilled in the art to make and use my invention, I will describe the same more fully, referring to the accompanying drawings, in which—

Figure 1 is a longitudinal section of the rope-clamp and sleeve, illustrating my invention. Fig. 2 is a face view showing the collar open, such as in inserting the clamps in the collar; and Fig. 3 is a top view.

Like letters of reference indicate like parts in each figure.

In connection with the apparatus I employ the temper-screw *a*, at the base of which is the swivel *b*, this swivel having links *c* extending down therefrom and the links being connected to hooks *d'* on the sleeve or collar *d*. The sleeve or collar *d* in its preferred form is formed of two semi-cylindrical parts *e e*, hinged, as at *d<sup>2</sup>*, and connected at points opposite thereto in any suitable way, such as by a link *e<sup>2</sup>*, fitting over lugs *e'* on the two semi-cylindrical parts of the sleeve. When so closed, it is evident that the collar *d* will entirely encircle the faces which are journaled therein. Formed on the interior of the said collar is the annular dovetailed recess *f*, this recess being formed half in each part of the collar and receiving like dovetailed lugs or projections on the clamping-pieces.

The clamp *g* is formed of the two clamping-pieces *g h*, the clamping-piece *g* carrying

the clamping-arm  $g'$ , through which extends the screw  $g^2$ , said clamping-screw bearing against the lower end of the clamping-piece  $h$  and forcing it against the clamping-piece  $g$ .

5 The outer faces of the clamping-pieces are formed semi-cylindrical, and the two clamping-pieces thus forming a cylindrical clamp which fits within the sleeve or collar  $d$ , the clamping-pieces having shoulders  $r$ , which  
10 extend over the top face of the collar and being so supported thereon. The interior faces of the clamping-faces are preferably formed as counterparts of the wire rope, which they are intended to clamp—that is, having spiral  
15 recesses corresponding to the strands of the rope and longitudinal depressions corresponding to the wires thereof—so that the clamp, when closed, may take into the strands and wires of the rope and hold the same  
20 firmly. Each clamping-piece has also a dovetailed projection  $k$ , which preferably extends around the outer face of the same, the dovetailed projections fitting within the dovetailed recess  $f$  in the sleeve  $d$ , and the two  
25 clamping-pieces being thus firmly held within the sleeve or collar by the dovetailed connection formed by the projections  $k$  and recess  $f$ . The dovetailed projections  $k$  are, however, free to turn within the annular recess of the  
30 sleeve and interfere in no way with the ordinary operation of the clamp.

In order to open the clamp to insert the rope, the two pieces are turned within the collar until the division-line of the clamp coincides with the division-line of the collar, in  
35 which case, as the dovetail projection of one clamping-piece is entirely inclosed within the part of the annular dovetailed recess in the one part of the collar, the clamp may be opened  
40 in the ordinary way, the parts  $e e'$  of the collar carrying the two parts of the clamp and holding them firmly by means of such dovetailed connections, so that there is no liability whatever of the clamping-pieces dropping out  
45 of the collar when the collar is open. Full space, however, for the insertion of the rope is obtained in this way, and as soon as the rope is inserted the collar may be closed and the piece  $h$  forced against the clamping-piece  
50  $g$  by the clamping-screw  $g^2$  in the ordinary way.

The two parts of the clamp may be inserted in the dovetailed recess of the collar by opening the collar, as shown in Fig. 2, and first inserting the clamping-piece  $h$  and then inserting the clamp-piece  $g$ , which turns as its projection is inserted in the dovetailed recess, so  
55 that the clamping-arm  $g'$  may swing around the clamping-piece  $h$ . After being so inserted within the collar the two parts cannot be removed except by first turning back the clamp-  
60 piece  $g$ , carrying the clamping-arm, and consequently in the ordinary operations of the clamp there is no liability whatever of the smaller clamping-piece  $h$  dropping out of the collar and passing down into the well. 65

The clamp is simple in construction and efficient for the purpose, giving the necessary swivel for the rope below the swivel at the base of the clamping-screw and providing for the proper drilling with wire rope, though it  
70 may of course be employed to advantage in drilling with the ordinary Manila rope.

What I claim as my invention, and desire to secure by Letters Patent, is—

1. In apparatus for drilling Artesian wells, 75 the combination of a sleeve or collar composed of two parts hinged together and having an annular dovetailed recess therein, and a clamp formed of two clamping-pieces journaled within said collar and having dovetailed projections engaging with and turning  
80 within the dovetailed recess of the collar, substantially as and for the purposes set forth.

2. In apparatus for drilling Artesian wells, 85 the combination of a sleeve or collar composed of two parts hinged together and having an annular dovetailed recess therein, a clamp formed of two clamping-pieces journaled within said collar and having dovetailed projections engaging with and turning within the  
90 dovetailed recess of said collar, one of said clamping-pieces carrying a clamping-arm, and a clamping-screw, substantially as and for the purposes set forth.

In testimony whereof I, the said PATRICK 95 YORKE, have hereunto set my hand.

PATRICK YORKE.

Witnesses:

H. L. GOEHRING,  
ROBT. D. TOTTEN.