

(No Model.)

2 Sheets—Sheet 1.

# F. W. JOHNSTONE. LOCOMOTIVE ENGINE.

No. 493,776.

Patented Mar. 21, 1893.

FIG. 1-

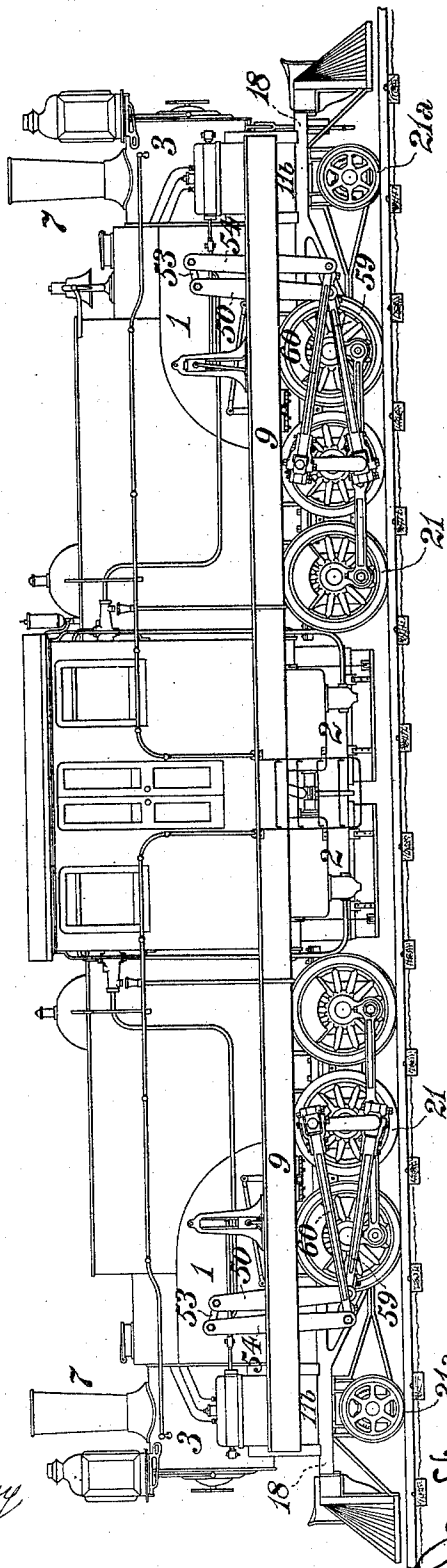

WITNESSES:

*R. A. Whittlesey*  
*F. C. Gaither*

INVENTOR,

*F. W. Johnstone,*  
*By*  
*J. Gordon Bell,*  
 Att'y.

F. W. JOHNSTONE.  
LOCOMOTIVE ENGINE.

No. 493,776.

Patented Mar. 21, 1893.

FIG. 2.

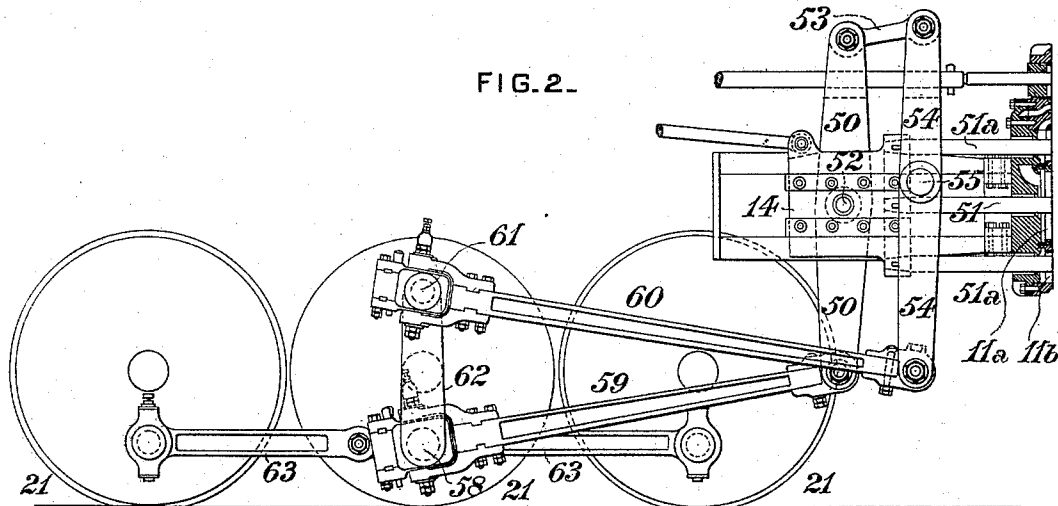
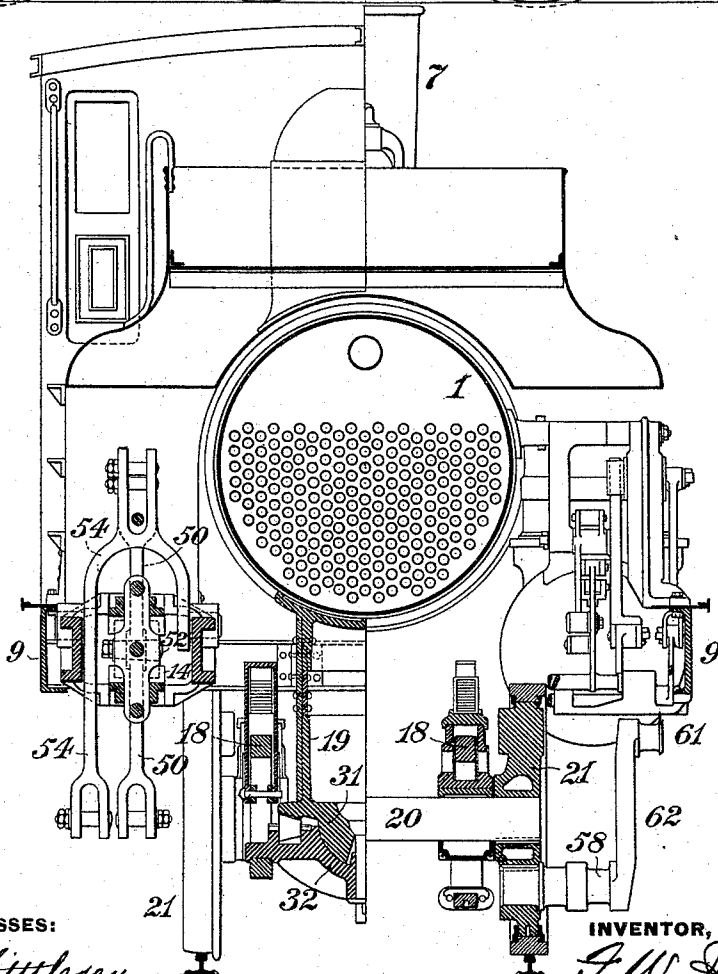

FIG. 3.



WITNESSES:

*A. H. Whittlesey*  
*J. C. Gaither*

INVENTOR,

*F. W. Johnstone*  
*by J. Rowden Bell*  
Att'y.

# UNITED STATES PATENT OFFICE.

FRANCIS W. JOHNSTONE, OF MEXICO, MEXICO.

## LOCOMOTIVE-ENGINE.

SPECIFICATION forming part of Letters Patent No. 493,776, dated March 21, 1893.

Application filed January 10, 1893. Serial No. 457,923. (No model.)

*To all whom it may concern:*

Be it known that I, FRANCIS W. JOHNSTONE, a citizen of the United States, residing at the city of Mexico, in the Republic of Mexico, have invented a certain new and useful Improvement in Locomotive-Engines, of which improvement the following is a specification.

My invention relates to locomotive engines of the class or type, designed to exert large tractive force with the capacity of easy passage around curves of comparatively short radius, in which the boiler and cylinders of the engine are secured upon a rigid frame, and the driving wheels are mounted in a truck swiveling relatively to said rigid frame, the piston rod cross heads and the driving wheels being coupled through interposed lever connections. Instances of the type referred to are fully set forth in Letters Patent of the United States No. 331,973, granted and issued to me under date of December 8, 1885, and the object of my present invention is to effect a further improvement in the construction which forms the subject of said Letters Patent, by the attainment of greater simplicity, reduction in cost, and more ready applicability to the conditions of service.

To this end, my invention, generally stated, consists in the combination, in a locomotive engine of the above type, of cross head levers journaled to the piston rod cross heads, fixed fulcrum levers journaled in the main frame, tension rods coupling the cross head levers and fixed fulcrum levers at their upper ends and connecting rods coupling the lower ends of the cross head levers and fixed fulcrum levers to main and to opposite return crank pins respectively, on a single pair of driving wheels.

The improvement claimed is hereinafter fully set forth.

In the accompanying drawings: Figure 1 is a side view, in elevation, of a double bogie compound locomotive engine, illustrating an application of my invention; Fig. 2, a similar view, on an enlarged scale, illustrating the lever connections between the cross heads and crank pins, and Fig. 3, a transverse section, the left hand half being taken partly through the cross head guide and partly through the center bearing, and looking toward one of the

fireboxes, and the right hand half being taken through the center of a main driving axle, and looking toward one of the stacks.

The locomotive engine in which my invention is herein illustrated as applied, is designed for freight service on long and heavy grades, having curves of such short radius that engines of the ordinary decapod or consolidation types cannot be employed with advantage; and is what is termed a double bogie compound engine. In this construction, two locomotive boilers 1, 1, are secured upon a rigid frame 9, their fireboxes 2, 2, facing each other and being set at such distance apart as to enable the engine to be operated by one engineer and one fireman, and their smoke boxes 3, and stacks 7, being located adjacent to the opposite ends of the rigid frame. A pair of compound engines having inner high pressure cylinders 11<sup>a</sup> and outer annular low pressure cylinders 11<sup>b</sup>, of the type set forth in my Letters Patent No. 464,175, dated December 1, 1891, is secured to the smoke box 3 of each boiler and to the adjacent portions of the frame 9, and the two boilers 1, 1, are supported, respectively, upon independent swiveling trucks or bogies, each having a complete wheel system, composed of six driving wheels 21 and a pair of guide or pony truck wheels 21<sup>a</sup>, whose axles are mounted in boxes in main truck frames 18, and accessory pony truck frames swiveling therein, the main truck frames being adapted to swivel or vibrate in a horizontal plane, independently of the rigid main frame 9 of the engine, about the axes of center bearings 19, connected with the main frame 9, each center bearing carrying, on its lower end, a ball casting 31, which fits into a corresponding socket casting 32, secured to the main frame 18 of the adjacent supporting truck or bogie. The motion of the several pistons is, as in Patent No. 331,973 aforesaid, transmitted from their connected cross heads to the driving wheels, through a system of lever connections, and except as to the novel features of such system, as presently to be described, the construction, as above generally recited, is not claimed as of my present invention.

In the practice of my invention, a double armed cross head lever 50, is journaled, by a

pin 52, to each cross head 14, in line with the piston rod 51 of its high pressure cylinder 11<sup>a</sup>. The upper arms of the cross head levers are coupled, by tension rods 53, to the upper arms of double armed fixed fulcrum levers 54, having journals 55 mounted in bearings connected to the main frame 9. The lower arms of the cross head levers 50 are coupled to the crank pins 58, of the main driving wheels, by the main connecting rods 59, and the lower arms of the fixed fulcrum levers 54, are coupled by the tension connecting rods 60, to return crank pins 61, on return cranks 62, fixed upon the main crank pins 58. The main crank pins are connected to the crank pins of the front and rear driving wheels, by side or coupling rods 63 in the ordinary manner.

The arms of the fixed fulcrum lever 54 are unequal in length, the upper and lower arms being in the proportions of, say, one to one and two tenths, and the lower and upper arms of the return crank 62 (being, respectively, the distance on the center line of said crank from the center of the crank pin 58 to the center of the main driving axle 20, and the distance from the center of the main axle to the center of the return crank pin 61) are unequal in a similar proportion. Under such construction, the advance and recession of the driving wheels in adjusting themselves to curves are admitted, as is the case in the constructions of Patent No. 331,973, without affecting the travel of the pistons and cross heads, and without necessitating undue or excessive clearance in the cylinders to compensate the swiveling movement of the bogies, and, further, the pressures on the connecting rods 59 and 60 being equalized, and in opposite directions, the tendency of the alternate pull and thrust of the connecting rods 59 to force the driving wheels and their frames out of normal position, and thereby to swivel the bogies on their centers at every stroke, is fully counteracted. The length of the connecting rods remains constant, one end being solid, and the other being fitted with a strap and brasses, as shown, and the straps which carry the brasses are pivoted to the stub ends of the rods, so as to form universal joints, admitting of the variation of the center lines of the main crank pins from perpendicularity to those of the connecting rods, when passing around curves, this feature, however, not being claimed as of my present invention. When traversing a straight track, the cross head levers 50 remain perpendicular at all points of the traverse of the cross heads, but in the swiveling of the bogies in passing around curves, these levers incline forward or backward, as the case may be, and remain in such inclined position until the engine passes off the curve or until the radius of the curve changes.

The combination of interposed cross head levers and fixed fulcrum levers, with connec-

tions to the pistons of cylinders supported on a rigid frame, and with connections to the crank pins of driving wheels mounted in a truck or bogie swiveling relatively to said frame, forms part of the subject matter of Letters Patent No. 331,973, before referred to, and such combination is not, therefore, broadly claimed as of my present invention. Further, I do not broadly claim a combination of the elements last above recited, in which both the cross head levers and the fixed fulcrum levers are coupled to crank pins on the driving wheels, as such combination, in its broad terms, is set forth in Fig. 29, and the descriptive matter referring thereto, in said Letters Patent No. 331,973. It will be seen, however, that under the construction which forms the subject of my present invention, both levers of each pair of compound engine cylinders are coupled to crank pins on the same driving wheel, thereby admitting of the employment of the ordinary side or coupling rods, which is not practicable with the construction of Patent No. 331,973, last referred to, and, also, enabling piston rods projecting from the front ends of the cylinders, and intermediate gearing connections for the driving wheels, to be dispensed with.

I claim as my invention and desire to secure by Letters Patent—

1. The combination, substantially as set forth, of a rigid main frame carrying a locomotive boiler, a series of driving wheels mounted in a truck or bogie frame adapted to move about a center bearing fixed to the main frame, steam cylinders fixed to the main frame, cross head levers journaled to the piston rod cross heads of said cylinders, fixed fulcrum levers journaled on the main frame, tension rods coupling the cross head levers and fixed fulcrum levers at their upper ends, and connecting rods coupling the lower ends of the cross head levers and fixed fulcrum levers to main and to opposite return crank pins, respectively, on a single pair of driving wheels.

2. In an engine of the type described, the combination, substantially as set forth, of cross head levers journaled to the piston rod cross heads, fixed fulcrum levers, journaled on the main frame, tension rods coupling the cross head levers and fixed fulcrum levers at their upper ends, return cranks fixed upon the crank pins of a pair of main driving wheels and having pins opposite the main crank pins, and connecting rods coupling the lower ends of the cross head levers and fixed fulcrum levers to the main and to the return crank pins.

3. In an engine of the type described, the combination, substantially as set forth, of cross head levers journaled to the piston rod cross heads, fixed fulcrum levers having arms of unequal length and journaled on the main frame, tension rods coupling the cross head le-

vers and fixed fulcrum levers at their upper ends, return cranks fixed upon the crank pins of a pair of main driving wheels and having pins opposite the main crank pins and at a distance from the center of the main driving axle different from the distance of the main crank pins therefrom, and connecting rods coupling the lower ends of the cross head levers and fixed fulcrum levers to the main and to the return crank pins.

FRANCIS W. JOHNSTONE.

Witnesses:

RICHARD GUENTHER,

F. E. TRAINER.