

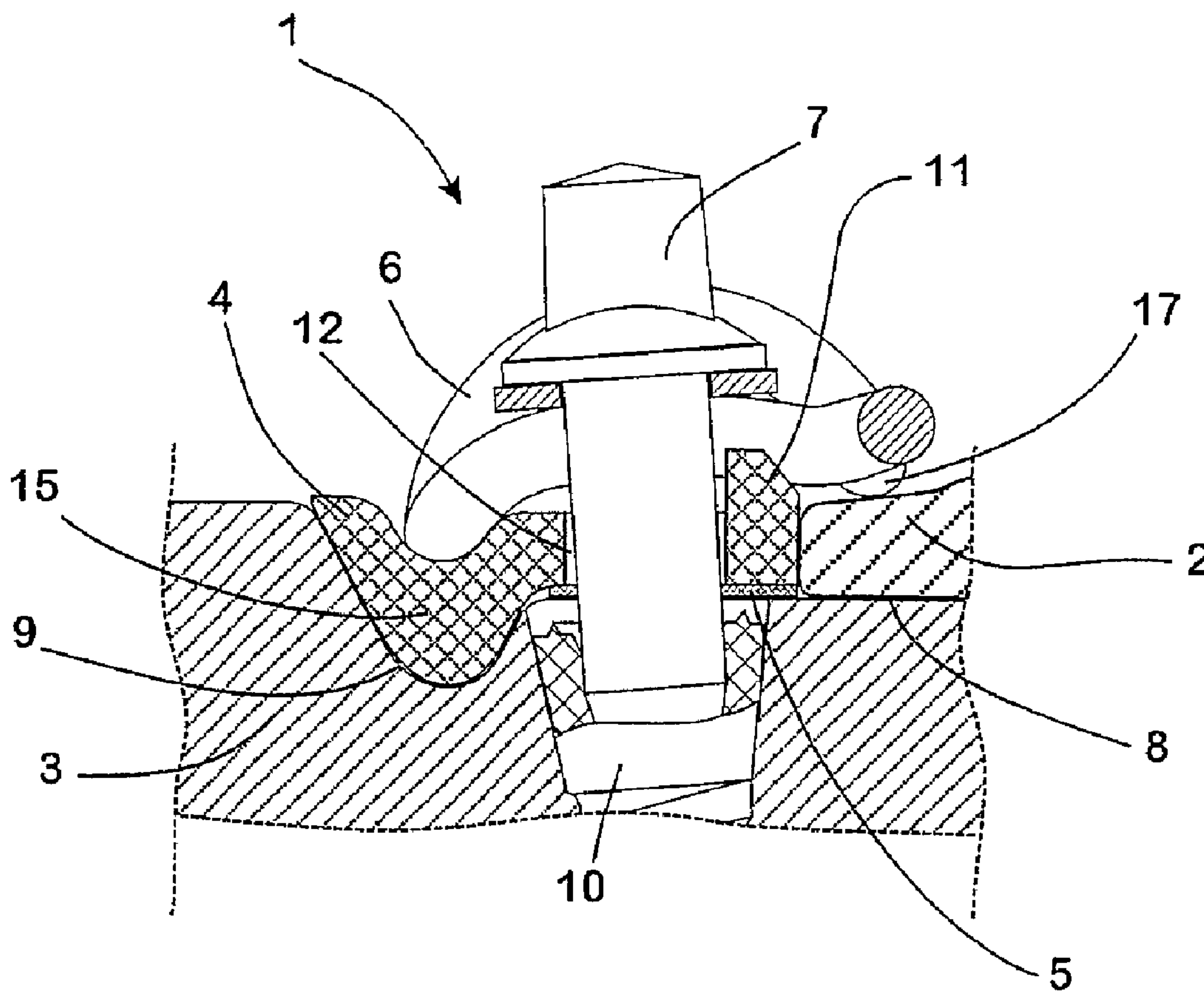

(86) Date de dépôt PCT/PCT Filing Date: 2004/08/05
 (87) Date publication PCT/PCT Publication Date: 2006/01/12
 (45) Date de délivrance/Issue Date: 2012/07/10
 (85) Entrée phase nationale/National Entry: 2006/12/21
 (86) N° demande PCT/PCT Application No.: EP 2004/008756
 (87) N° publication PCT/PCT Publication No.: 2006/002682
 (30) Priorité/Priority: 2004/07/01 (DE10 2004 032 055.1)

(51) Cl.Int./Int.Cl. *E01B 9/28* (2006.01),
E01B 9/68 (2006.01)
 (72) Inventeurs/Inventors:
VORDERBRUECK, DIRK, DE;
BOESTERLING, WINFRIED, DE
 (73) Propriétaire/Owner:
VOSSLOH-WERKE GMBH, DE
 (74) Agent: KIRBY EADES GALE BAKER

(54) Titre : PLAQUE A GUIDAGE ANGULAIRE, ET SYSTEME POUR FIXER DES RAILS POUR VEHICULES SUR RAILS
 (54) Title: ANGULAR GUIDE PLATE AND SYSTEM FOR FASTENING RAILS FOR RAIL VEHICLES



(57) Abrégé/Abstract:

The present invention relates to an angular guide plate and to a system for fastening rails for rail vehicles, which angular guide plate and system are equipped with a supporting surface via which the angular guide plate is positioned on a solid foundation in its



(57) **Abrégé(suite)/Abstract(continued):**

assembly position, in particular in a system in which a spring element for applying the required holding force to the rail is supported on the angular guide plate in the assembly position. The angular guide plate according to the invention allows the abrasive wear of angular guide plate or foundation that occurs in the prior art to be minimised. This is achieved in that the supporting surface is overlaid at least in certain sections with a resilient layer.

ABSTRACT

The present invention relates to an angular guide plate and to a system for fastening rails for rail vehicles, which angular guide plate and system are equipped with a supporting surface via which the angular guide plate is positioned on a solid foundation in its assembly position, in particular in a system in which a spring element for applying the required holding force to the rail is supported on the angular guide plate in the assembly position. The angular guide plate according to the invention allows the abrasive wear of angular guide plate or foundation that occurs in the prior art to be minimised. This is achieved in that the supporting surface is overlaid at least in certain sections with a resilient layer.

**ANGULAR GUIDE PLATE AND SYSTEM
FOR FASTENING RAILS FOR RAIL VEHICLES**

The invention relates to an angular guide plate for fastening rails for rail vehicles, which angular guide plate is equipped with a supporting surface via which the angular guide plate is positioned on a solid foundation in its assembly position. The invention also relates to a system for fastening a rail for rail vehicles, comprising an angular guide plate which can be positioned with a supporting surface on a foundation, and on which angular guide plate a spring element for applying the required holding force to the rails is supported in the assembly position. Angular guide plates and fastening systems of this type are known in many variations (see for example DE-AS 1 954 008, EP 0 231 304 B1 and DE 33 34 119 A1).

The purpose of the angular guide plates lies in supporting the spring element, which exerts the required resilient holding force on the rail foot, in the fully assembled state. At the same time the angular guide plate provides a lateral support for the rail foot via which the rail is held in the respectively prescribed longitudinal alignment. This renders a firm, exactly aligned seat of the angular guide plate on the respective foundation necessary.

The known angular guide plates and the fastening systems equipped therewith have been tried and tested in operation. However, under certain operating conditions

increased wear in the region of the supporting surface, with which the angular face is supported on the foundation supporting the rail with fastening system as a whole, has been found. This wear manifests itself in material removal from the supporting surface of the angular plate and/or the support area of the foundation on which the angular plate rests.

Particles, which pass between the supporting surface of the angular guide plate and the support area of the foundation, have been determined as the cause of the increased wear. This wear phenomenon occurs in a particularly dramatic manner in fastening systems in which the rails are fastened to concrete sleepers and which are used in regions where high levels of dust are produced as well as possible sand drifts, etc.

The object of the invention therefore consisted in providing an angular guide plate in which the risk of abrasive wear in the region of its supporting surface is minimised. The intention was also to provide a system for fastening rails in which, with simple means, the risk of abrasive wear occurring in the region of the angular guide plate is reduced to a minimum even under unfavourable operating conditions.

With respect to an angular guide plate for fastening rails for rail vehicles, which angular guide plate is equipped with a supporting surface via which the angular guide plate is positioned on a solid foundation in its assembly position, this object is achieved in that the supporting surface is overlaid at least in certain sections with a resilient layer.

In the region of its supporting surface an angular guide plate according to the invention comprises a resilient layer via which it rests in its assembly position on the support area of the foundation bearing the angular guide plate. This resilient layer prevents gaping of a gap between the supporting surface of the angular guide plate and the support area of the foundation even if when the rails are driven over the angular guide plate is moved, owing to the weight of the rail vehicle and the dynamic movements associated therewith of the rails, in the horizontal or vertical direction relative to the foundation.

Surprisingly it has been found that the penetration of particles into the critical region between angular guide plate and substrate may thus be durably prevented. Furthermore, the resilient layer damps the effect of such particles which, despite the seal created by the invention, pass into the region between angular guide plate and foundation. As a result the invention thus minimises the abrasive wear of angular guide plate or foundation that occurs in the prior art.

In a system for fastening a rail for rail vehicles, which system is equipped with an angular guide plate which can be positioned with a supporting surface on a foundation and on which a spring element for applying the required holding force to the rail is supported in the assembly position, said object is correspondingly achieved therefore in that the system comprises a resilient layer for insertion between the supporting surface of the angular guide plate and the solid foundation.

Practical tests have shown that with a rail fastening system constructed in this way the resilient layer between angular guide plate and foundation does not have an adverse effect on the retention of the rail or the security and accuracy of the fastening, but instead makes only positive contributions to the life of the fastening system constructed in such a manner according to the invention. Since the purpose of the resilient layer consists only in sealing a gap that may potentially occur between angular guide plate and foundation during operation, the resilient layer should be configured in such a way that in the assembly position it largely does not influence the flexibility of the fastening system in which it is respectively used.

As a function of the respectively processed material, it is therefore sufficient, as a rule, if a thin resilient layer is used, of which the thickness is much less than the thickness of the angular guide plate in the region of the supporting surface. The thickness of the resilient layer can thus be limited for example to at most 10 % of the average thickness of the angular guide plate in the region of the supporting surface.

As a result of the fact that the resilient layer does not have a spring function it is, moreover, preferably configured in such a way that it is compressed as much as possible by the assembly forces acting on the angular guide plate in its assembly position. A particularly good effect of the resilient layer thus results if it is completely, or at least almost completely, compressed when the angular guide plate is fully assembled.

As a rule it is sufficient if, in the regions in which gaps may form between the support area and the supporting surface during practical operation, the supporting surface of the angular guide plate is overlaid by the resilient layer. It is thus conceivable for example to overlay only the edge regions of the supporting surface that are critical in this regard with a thin resilient strip which then constitutes the resilient layer. Particularly reliable transfer of the forces acting on the angular guide plate during assembly and operation may be achieved however, if the resilient layer covers the supporting surface all-over.

All materials, of which the elasticity is retained even after a relatively long compression, are suitable as material for the resilient layer. As a result the resilient layer is preferably made of a polyurethane, a rubber or any other elastomer material. These materials are inexpensive to obtain and stretch sufficiently quickly, even in the event of a gap forming for a short time between angular guide plate and foundation, to prevent penetration of particles, such as dust or sand, into the critical regions.

To facilitate assembly of the angular guide plate according to the invention the resilient layer may be permanently connected to the angular guide plate. This can be achieved for example by suitable mould parts, etc. which hold the resilient layer positively and/or non-positively on the angular guide plate. It has proven to be particularly expedient, however, if the resilient layer is connected to the supporting surface of the angular guide plate with integral fit, for example by gluing or vulcanising. This type of integral connection

between resilient layer and angular guide plate also prevents particles from passing into the region between the resilient layer and the supporting surface and causing wear at this point.

The invention may be used particularly effectively in systems in which the rails are fastened to a sleeper which forms the solid foundation for the angular guide plate. This applies in particular if the sleeper is made from a concrete material. It is precisely in the case of concrete sleepers, or sleepers produced from comparable materials that are particularly sensitive to abrasive wear, that the advantages achieved by arrangement according to the invention of a resilient layer between angular guide plate and sleeper are demonstrated.

The invention will be described in more detail hereinafter with reference to drawings that illustrate an embodiment. In the drawings, schematically in each case:

Fig. 1 shows in longitudinal section a system for fastening a rail for a rail vehicle,

Fig. 2 shows an angular guide plate in a view from below.

The system 1 is used for fastening a rail 2, of which only the edge of the rail foot facing the system 1 is shown in Fig. 1. It comprises a concrete sleeper 3, an angular guide plate 4, a resilient layer 5, as a spring element for production of the required holding force a tightening clip 6, and a tightening screw 7 for tightening the tightening clip 6.

The concrete sleeper 3 comprises a level support area 8 in which, in the region of its lateral end, a channel 9 is formed. The lateral end region, adjoining the channel 9, of the support area 8 forms the region on which the angular guide plate 4 rests in the assembly position. An indentation, in which a plastics material pin 10 for the tightening screw 7 sits, is formed in a central position in this end region.

At its upper side the angular guide plate 4, which is shaped in a manner known per se, has mould parts 11 which guide the tightening clip 6 in its assembly position and ensure reliable transfer of the holding forces to the foot of the rail 2. Starting from its upper side, a through-aperture 12 is also formed in the angular guide plate 4, through which through-aperture 12 the tightening screw 7 for tightening the tightening clip 6 is guided during assembly in a manner that is likewise already known per se, in order to screw the tightening screw 7 into the plastics material pin 10 of the sleeper 3.

Formed at the lower side of the angular guide plate 4 is a level supporting surface 13 which in the assembly position is limited at its edge facing away from the rail 2 by a bulge 14 extending along this edge. The bulge 14 also carries projections 15, of which the cross-sectional shape is adapted to the cross-section of the channel 9.

Glued to the supporting surface 13 is the thin resilient layer 5 which covers the supporting surface 13 all-over, while leaving the through-aperture 12 and recesses 16 free. The recesses 16 are formed in the supporting surface 13 at the edge associated with the rail 2 in the assembly position.

The resilient layer 5 is made of a fine porous, highly resilient polyurethane foam, of which the elasticity is such that it immediately automatically slackens and stretches to the initial thickness of the resilient layer 5 again even in the event of a load alleviation that suddenly occurs after relatively long complete compression. This starting thickness is at most 8 % of the average thickness of the angular guide plate 4 in the region of its supporting surface 13.

To assemble the system 1 the angular guide plate 4 is placed on the support area 8 in such a way that the projections 15 formed on the lower side of the angular guide plate 4 positively grip in the channel 9 and thus secure the angular guide plate 4 against a displacement in the longitudinal direction of the sleeper 3. The supporting surface 13 rests on the end region of the support area 8 above the resilient layer 5 in such a way that the through-aperture 12 of the angular guide plate 4 is aligned with the pin 10 of the sleeper 3.

The tightening clip 6 that is conventionally constructed in a W-shape is subsequently positioned on the angular guide plate 4 in such a way that its holding arms 17 rest with their free ends on the foot of the rail 2. By screwing the tightening screw 7 into the pin 10 the tightening clip 6 is fixed until the required resilient holding force is exerted on the foot of the rail 2.

During the course of tightening of the tightening clip 6 the resilient layer is completely compressed to the extent that its elasticity no longer has an effect on the overall elasticity of the system 1. If, owing to the

movements in the system 1 that occur when a rail vehicle (not shown) travels over the rail 2, the angular guide plate 4 is raised from the support area of the concrete sleeper 3, the resilient layer 5 stretches and fills the gap forming in this case between the support area 8 and the supporting surface 13 of the angular guide plate 4. This prevents particles from getting between the angular guide plate 4 and the concrete sleeper 3 and causing abrasive wear at this point.

Owing to the seal according to the invention thus achieved by the resilient layer 5 between the angular guide plate 4 and the concrete sleeper 3, a system 1 according to the invention is particularly suitable for fastening rails 2 in dry regions in which a rail body equipped with rails 2 and systems 1 is exposed to severe sand or dust drifts.

List of reference numerals

- 1 system for fastening a rail 2
- 2 rail, of which only the rail foot is shown in Fig. 1
- 3 concrete sleeper
- 4 angular guide plate
- 5 resilient layer
- 6 tightening clip
- 7 tightening screw
- 8 support area
- 9 channel
- 10 plastics material pin
- 11 mould parts which guide the tightening clip 6 in its assembly position
- 12 through-aperture
- 13 supporting surface
- 14 bulge
- 15 projections
- 16 recesses
- 17 holding arms of the tightening clip 6

CLAIMS

1. Angular guide plate for fastening rails for rail vehicles, which angular guide plate is equipped with a supporting surface formed at the lower side of the angular guide plate the supporting surface being assigned to position the angular guide plate on a solid foundation in an assembly position, wherein the supporting surface of the angular guide plate is overlaid at least in some sections with a resilient layer, the resilient layer being placed at the supporting surface of the angular guide plate.

2. Angular guide plate according to claim 1, wherein the thickness of the resilient layer is at most 10% of the average thickness of the angular guide plate in the region of the supporting surface.

3. Angular guide plate according to any one of claims 1 and 2, wherein the resilient layer is substantially completely compressed by assembly forces acting on the angular guide plate in its assembly position.

4. Angular guide plate according to any one of claims 1 to 3, wherein the resilient layer covers the supporting surface all-over.

5. Angular guide plate according to any one of claims 1 to 4, wherein the resilient layer is made of one of a polyurethane, a rubber and another elastomer material.

- 12 -

6. Angular guide plate according to any one of claims 1 to 5, wherein the resilient layer is integrally connected to the supporting surface of the angular guide plate.

7. System for fastening a rail for rail vehicles, comprising an angular guide plate which is positionable with a supporting surface on a foundation, and on which a spring element for applying a required holding force to the rail is supported in an assembly position, and a resilient layer for insertion between the supporting surface of the angular guide plate and the solid foundation.

8. System according to claim 7, wherein the resilient layer is substantially completely compressed when the system is fully assembled.

9. System according to either claim 7 or 8, further comprising a sleeper which forms the solid foundation for the angular guide plate.

10. System according to claim 9, wherein the sleeper is made from a concrete material.

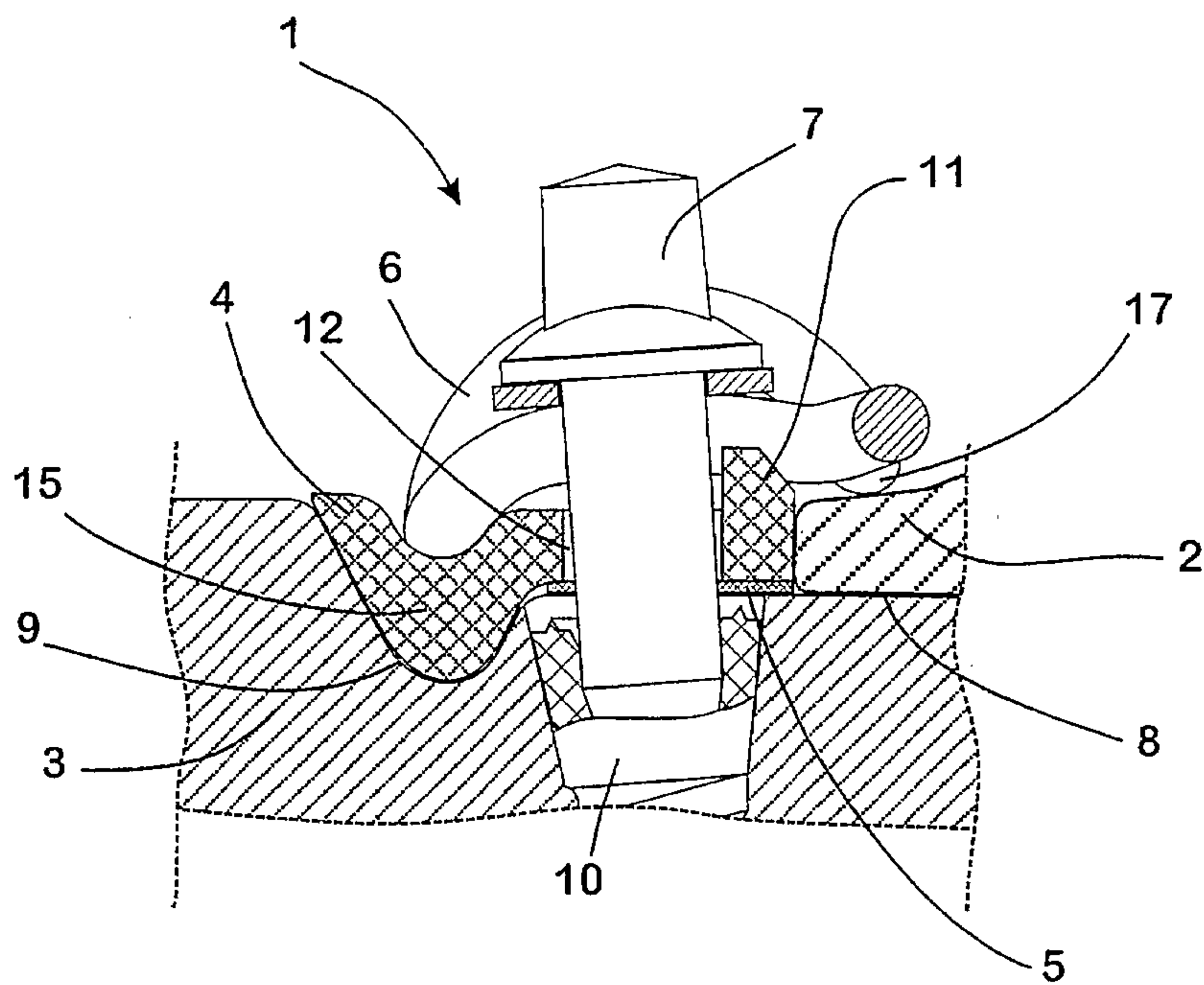

Fig. 1

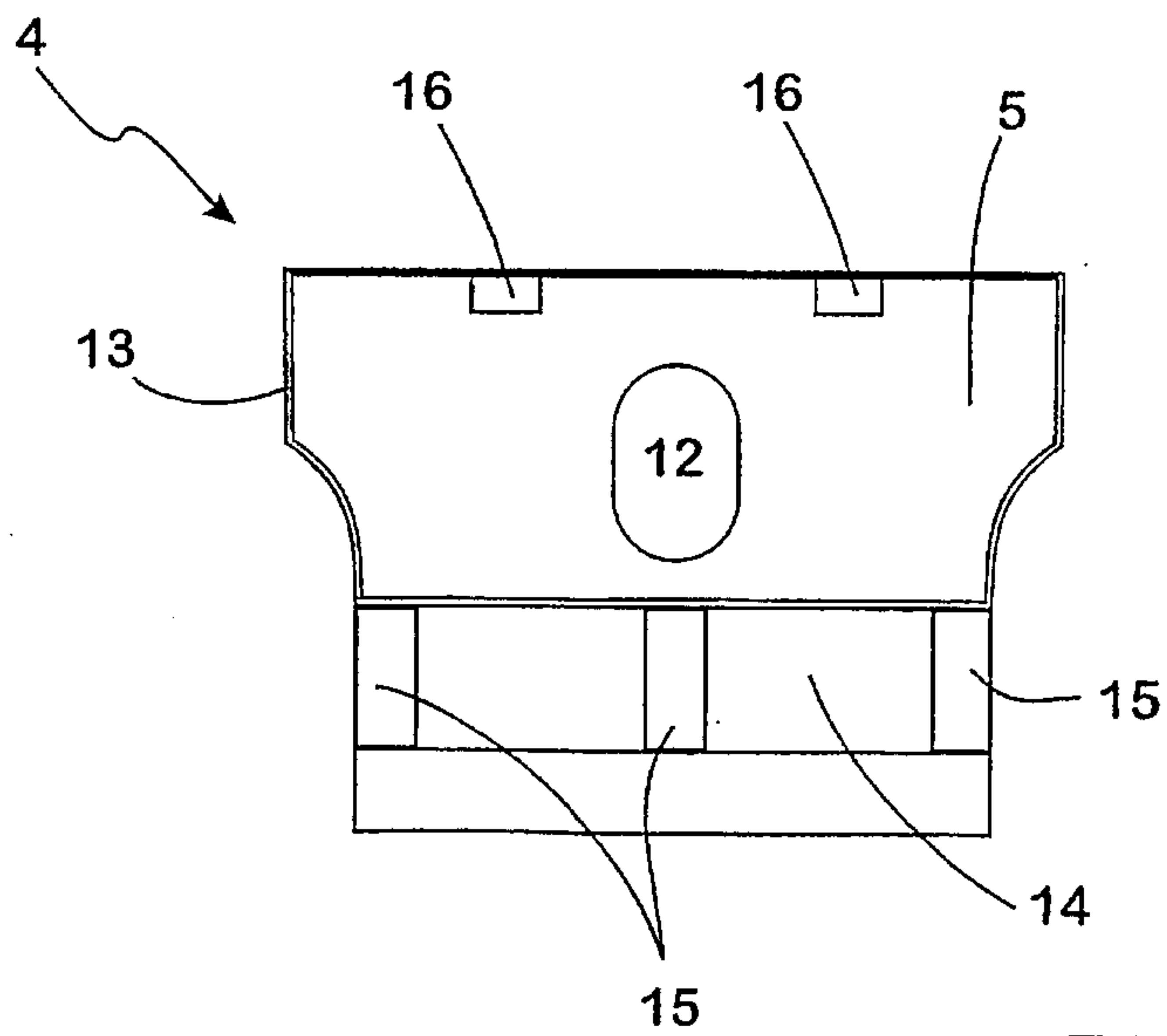

Fig. 2

