



- (51) International Patent Classification:
G09B 19/00 (2006.01) G06K 9/00 (2006.01)
- (21) International Application Number:
PCT/JP2015/002070
- (22) International Filing Date:
14 April 2015 (14.04.2015)
- (25) Filing Language: English
- (26) Publication Language: English
- (30) Priority Data:
2014-088030 22 April 2014 (22.04.2014) JP
- (71) Applicant: SONY CORPORATION [JP/JP]; 1-7-1 Konan, Minato-ku, Tokyo, 1080075 (JP).
- (72) Inventors: HASHIMOTO, Hirokazu; c/o SONY CORPORATION, 1-7-1 Konan, Minato-ku, Tokyo, 1080075 (JP). MURAKOSHI, Sho; c/o SONY CORPORATION, 1-7-1 Konan, Minato-ku, Tokyo, 1080075 (JP). OKAMOTO, Hiroshige; c/o SONY CORPORATION, 1-7-1 Konan, Minato-ku, Tokyo, 1080075 (JP).
- (74) Agents: KAMEYA, Yoshiaki et al.; HAZUKI INTERNATIONAL YOTSUYA, Daiichi Tomizawa Building, 3-1-3, Yotsuya, Shinjuku-ku, Tokyo, 1600004 (JP).

- (81) Designated States (unless otherwise indicated, for every kind of national protection available): AE, AG, AL, AM, AO, AT, AU, AZ, BA, BB, BG, BH, BN, BR, BW, BY, BZ, CA, CH, CL, CN, CO, CR, CU, CZ, DE, DK, DM, DO, DZ, EC, EE, EG, ES, FI, GB, GD, GE, GH, GM, GT, HN, HR, HU, ID, IL, IN, IR, IS, KE, KG, KN, KP, KR, KZ, LA, LC, LK, LR, LS, LU, LY, MA, MD, ME, MG, MK, MN, MW, MX, MY, MZ, NA, NG, NI, NO, NZ, OM, PA, PE, PG, PH, PL, PT, QA, RO, RS, RU, RW, SA, SC, SD, SE, SG, SK, SL, SM, ST, SV, SY, TH, TJ, TM, TN, TR, TT, TZ, UA, UG, US, UZ, VC, VN, ZA, ZM, ZW.
- (84) Designated States (unless otherwise indicated, for every kind of regional protection available): ARIPO (BW, GH, GM, KE, LR, LS, MW, MZ, NA, RW, SD, SL, ST, SZ, TZ, UG, ZM, ZW), Eurasian (AM, AZ, BY, KG, KZ, RU, TJ, TM), European (AL, AT, BE, BG, CH, CY, CZ, DE, DK, EE, ES, FI, FR, GB, GR, HR, HU, IE, IS, IT, LT, LU, LV, MC, MK, MT, NL, NO, PL, PT, RO, RS, SE, SI, SK, SM, TR), OAPI (BF, BJ, CF, CG, CI, CM, GA, GN, GQ, GW, KM, ML, MR, NE, SN, TD, TG).

Published:
— with international search report (Art. 21(3))

(54) Title: INFORMATION PROCESSING APPARATUS, INFORMATION PROCESSING METHOD, AND COMPUTER PROGRAM

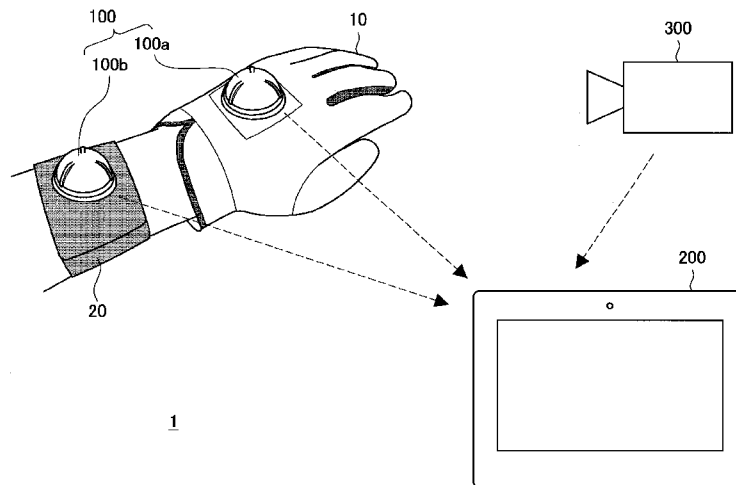

(57) Abstract: An apparatus includes a communications interface that receives first sensed data from a first sensor attached to a user and second sensed data from a second sensor attached to a user. That apparatus also includes circuitry that analyzes the first sensed data and the second sensed data and provides a display signal that causes a display to produce first visual information regarding a motion of the user and second visual information regarding the motion of the user, the first visual information being different than the second visual information.

WO 2015/162871 A1

Description

Title of Invention: INFORMATION PROCESSING APPARATUS, INFORMATION PROCESSING METHOD, AND COMPUTER PROGRAM

CROSS REFERENCE TO RELATED APPLICATIONS

[0001] This application claims the benefit of Japanese Priority Patent Application JP 2014-088030 filed April 22, 2014, the entire contents of which are incorporated herein by reference.

Technical Field

[0002] The present disclosure relates to an information processing apparatus, an information processing method, and a computer program.

Background Art

[0003] Many technologies for helping a user become proficient in a sport through sensing and analyses have been developed. Among the technologies, statistically analyzing a play of a user and other users is used as one technique. Thus, a technology for automatically analyzing a motion by mounting a sensor device formed by installing sensors such as an acceleration sensor and a gyro sensor on a user or wearable equipment used by the user and analyzing sensed data acquired by the sensors has been proposed (for example, refer to PTL 1).

Citation List

Patent Literature

[0004] PTL 1: JP 2012-157644A

Summary

Technical Problem

[0005] A motion of a player can be visualized when sensed data from a single sensor is used. Thus, if sensed data from a plurality of sensors is used in analysis for analysis and visualization of a motion of a player, the motion of the player can be multi-laterally visualized.

[0006] Therefore, the present disclosure proposes a novel and improved information processing apparatus, information processing method, and computer program that can generate information which visualizes a motion of a player multi-laterally using information from a plurality of sensors.

Solution to Problem

[0007] Accordingly to one non-limiting aspect, an apparatus is provided that includes a communications interface that receives first sensed data from a first sensor attached to

a user and second sensed data from a second sensor attached to a user. That apparatus also includes circuitry that analyzes the first sensed data and the second sensed data and provides a display signal that causes a display to produce first visual information regarding a motion of the user and second visual information regarding the motion of the user, the first visual information being different than the second visual information

[0008] According to another non-limiting aspect, a method is provided that includes collecting first sensed data from a first sensor attached to a user and second sensed data from a second sensor attached to a user; sending via a communications interface the first sensed data and the second sensed data to analysis circuitry; and receiving from the analysis circuitry a display signal and displaying first visual information regarding a motion of the user and second visual information regarding the motion of the user, the first visual information being different than the second visual information.

[0009] According to another non-limiting aspect, an apparatus is provided that includes a communications interface configured to receive first sensed data from a first sensor attached to a user and a second sensed data from a second sensor attached to a user; circuitry configured to analyze the first sensed data and the second sensed data and provide a display signal that causes a display to produce first visual information regarding a motion of the user and second visual information regarding the motion of the user, the first visual information being different than the second visual information; and the display configured to display the first visual information and the second visual information.

Advantageous Effects of Invention

[0010] According to an embodiment of the present disclosure described above, a novel and improved information processing apparatus, information processing method, and computer program that can generate information which visualizes a motion of a player multi-laterally using information from a plurality of sensors can be provided.

[0011] Note that the effects described above are not necessarily limited, and along with or instead of the effects, any effect that is desired to be introduced in the present specification or other effects that can be expected from the present specification may be exhibited.

Brief Description of Drawings

[0012] [fig.1]FIG. 1 is an explanatory diagram showing a configuration example of an information processing system 1 according to an embodiment of the present disclosure. [fig.2]FIG. 2 is an explanatory diagram showing a functional configuration example of

a sensor device 100 according to an embodiment of the present disclosure.

[fig.3]FIG. 3 is an explanatory diagram showing a functional configuration example of an information processing apparatus 200 according to an embodiment of the present disclosure.

[fig.4]FIG. 4 is an explanatory diagram showing an example of information 400 that the information processing apparatus 200 according to an embodiment of the present disclosure causes a display unit 240 to display.

[fig.5]FIG. 5 is a flowchart showing an operation example of the information processing apparatus 200 according to an embodiment of the present disclosure.

[fig.6]FIG. 6 is a flowchart showing an operation example of the information processing apparatus 200 according to an embodiment of the present disclosure.

[fig.7]FIG. 7 is a flowchart showing an operation example of the information processing apparatus 200 according to an embodiment of the present disclosure.

Description of Embodiments

[0013] Hereinafter, preferred embodiments of the present disclosure will be described in detail with reference to the appended drawings. Note that, in this specification and the appended drawings, structural elements that have substantially the same function and structure are denoted with the same reference numerals, and repeated explanation of these structural elements is omitted.

[0014] Note that description will be provided in the following order.

1. Embodiment of the present disclosure
 - 1.1. System configuration example
 - 1.2. Functional configuration example
 - 1.3. Information display example
 - 1.4. Analysis process example
2. Conclusion

[0015] 1. Embodiment of the present disclosure

- 1.1. System configuration example

First, a configuration example of an information processing system according to an embodiment of the present disclosure will be described with reference to a drawing. FIG. 1 is an explanatory diagram showing the configuration example of the information processing system 1 according to the embodiment of the present disclosure. The information processing system 1 according to the embodiment of the present disclosure shown in FIG. 1 is a system for visualizing and presenting changes in body states of a player playing golf by analyzing motions of the player. Other activities are contemplated as well such as tennis, or bowling where the user moves an object with his arm/wrist/hand along a predetermined trajectory. Hereinbelow, the configuration

example of the information processing system 1 according to the embodiment of the present disclosure will be described using FIG. 1.

- [0016] As shown in FIG. 1, the information processing system 1 according to the embodiment of the present disclosure is configured to include a sensor device 100a that is installed on a glove 10 that a player wears on his or her hand when playing golf, a sensor device 100b that is installed on a wrist band 20 that the player wraps around his or her wrist when playing golf, an information processing apparatus 200 that visualizes and presents changes in body states of the player using sensed data transmitted from the sensor devices 100a and 100b, and an imaging device 300 that images a figure of the player playing golf, particularly, a figure of the player swinging a golf club.
- [0017] The information processing apparatus 200 is an apparatus that processes and displays information, for example, a personal computer, a smartphone (high functional mobile telephone), a tablet-type terminal, or the like. In addition, the sensor devices 100a and 100b will be referred to simply as a sensor device 100 in description below when it is not necessary to distinguish them from each other.
- [0018] In the information processing system 1 according to the embodiment of the present disclosure shown in FIG. 1, the respective sensor devices 100a and 100b transmit sensed data to the information processing apparatus 200, and the information processing apparatus 200 analyzes the sensed data transmitted from the sensor devices 100a and 100b and presents an analyzed result. The result presented by the information processing apparatus 200 after analyzing the sensed data is a visualized change in a body state of the player playing golf.
- [0019] Note that, although FIG. 1 illustrates the information processing apparatus 200 and the imaging device 300 as separate devices, the present disclosure is not limited to the example. In other words, the information processing apparatus 200 and the imaging device 300 may be the same device.
- [0020] As shown in FIG. 1, the sensor device 100a is installed on the glove 10, and the sensor device 100b is installed on the wrist band 20. Thus, the sensor device 100a mainly senses motions of the back portion of the hand of the player, and the sensor device 100b mainly senses motions of the wrist portion of the player. In other words, the sensor devices 100a and 100b are equipped by the user such that the wrist joint of the player is interposed therebetween as shown in FIG. 1.
- [0021] With the configuration shown in FIG. 1, the information processing system 1 according to the embodiment of the present disclosure can cause the information processing apparatus 200 to analyze the sensed data obtained by the sensor devices 100a and 100b and to visualize and present information regarding a change in a body state of the player playing golf and a swing of a golf club. In addition, by causing the wearable equipment that is provided with the plurality of sensor devices 100a and 100b

to be mounted on the player such that the joint, for example, the wrist joint, is interposed between the devices, the information processing system 1 according to the embodiment of the present disclosure can obtain a change in a body state of the player that would otherwise be difficult to obtain with a single sensor device, for example, a time-series change in angles of the wrist of the player when, for example, swinging a golf club, and the like can be obtained.

[0022] Although the present embodiment shows the case in which the sensor device 100a is installed on the glove 10 and the sensor device 100b is installed on the wrist band 20, the present disclosure is not limited to the example. The sensor device 100 that obtains the sensed data can be mounted in various positions of the head, shoulders, waist, knees, and the like of the player in which a change in a body state of the player can be obtained.

[0023] The configuration example of the information processing system 1 according to the embodiment of the present disclosure has been described above using FIG. 1. Next, functional configuration examples of the respective devices constituting the information processing system 1 according to an embodiment of the present disclosure will be described.

[0024] 1.2. Functional configuration example

First, a functional configuration example of the sensor device 100 according to an embodiment of the present disclosure will be described. FIG. 2 is an explanatory diagram showing the functional configuration example of the sensor device 100 according to the embodiment of the present disclosure. Hereinbelow, the functional configuration example of the sensor device 100 according to the embodiment of the present disclosure will be described using FIG. 2.

[0025] As shown in FIG. 2, the sensor device 100 according to the embodiment of the present disclosure is configured to include a control unit 110, a battery 120, a memory 130, a sensor unit 140, and a communication unit 150.

[0026] The control unit 110 controls operations of the sensor device 100, and can be configured by, for example, a central processing unit (CPU), or the like. When the control unit 110 is configured by a CPU, the CPU can be configured by an electronic circuit.

[0027] The battery 120 is a battery for supplying power to the control unit 110, the memory 130, the sensor unit 140, and the communication unit 150. Note that the type of the battery 120 may be a secondary battery that can be charged repeatedly, or a primary battery that only can discharge.

[0028] The memory 130 stores various kinds of information, particularly information obtained by the sensor unit 140. The control unit 110, for example, causes the memory 130 to store information. In addition, the information stored in the memory 130 is, for

example, read by the control unit 110 and transmitted by the communication unit 150. The memory 130 is configured to be capable of retaining information even without supply of power from the battery 120; however, power is supplied from the battery 120 when information is written onto the memory 130 and when information is read from the memory 130. In addition, the memory 130 may store computer programs read and sequentially executed by the control unit 110.

[0029] The sensor unit 140 is constituted by sensors that acquire directions and attitudes of hitting equipment or wearable equipment on which the sensor device 100 is installed, impacts exerted on the wearable equipment, and other states thereof. In the present embodiment, the sensor unit 140 acquires impacts exerted on the glove 10 and wrist band 20 both having the sensor device 100 installed thereon and other states thereof. The sensor unit 140 operates by receiving supply of power from the battery 120. The sensors constituting the sensor unit 140 include, for example, an acceleration sensor with a single axis, three axes, six axes, nine axes, or the like, a gyro sensor (angular velocity), a geomagnetic sensor, and the like.

[0030] The sensor unit 140 may also include, for example, a shock sensor, and a motion sensor. The shock sensor is a sensor that detects impacts transmitted by the sensor device 100 from the user or the hitting equipment or wearable equipment, and can include, for example, an acceleration sensor with a single axis in the present embodiment. The motion sensor is a sensor that detects behaviors of the sensor device 100 with, for example, higher resolving power than the shock sensor, and can include, for example, acceleration sensors with three axes, six axes, and nine axes, a gyro sensor, a geomagnetic sensor, and the like in the present embodiment. The sensors can be realized using, for example, a piezo-resistance-type or capacitance-type acceleration sensor, and the like.

[0031] The sensor unit 140 may include all kinds of sensors for acquiring states of the hitting equipment and wearable equipment both having the sensor device 100 installed thereon, for example, a temperature sensor, a pressure sensor, a Global Positioning System (GPS) receiver, and the like, in addition to the above-described shock sensor and motion sensor.

[0032] The communication unit 150 transmits information to an external device, for example, the information processing apparatus 200. As information to be transmitted to the information processing apparatus 200, the communication unit 150 transmits information that, for example, is acquired by the sensor unit 140 with respect to the hitting equipment and wearable equipment both having the sensor device 100 installed thereon. The communication unit 150 transmits information using, for example, Bluetooth (a registered trademark), a wireless local area network (LAN), or the like. Note that, since the information acquired by the sensor unit 140 does not have to be

transmitted to the information processing apparatus 200 in real time, the communication unit 150 may transmit information to the information processing apparatus 200 through, for example, wired communication using a USB cable, a LAN cable, or the like after plays are finished.

[0033] The sensor unit 140 is illustrated as one block in FIG. 2, but when the sensor unit 140 is constituted by the motion sensor and the shock sensor as described above, for example, the battery 120 may supply power separately to the respective motion sensor and the shock sensor. In this case, the sensor device 100 can be separately provided with a switch for controlling power supply to the motion sensor and a switch for controlling power supply to the shock sensor. The control unit 110 can control operations of the switches such that power supply to any one of the motion sensor and the shock sensor is stopped.

[0034] The functional configuration example of the sensor device 100 according to the embodiment of the present disclosure has been described above using FIG. 2. Next, the functional configuration example of the information processing apparatus 200 according to the embodiment of the present disclosure will be described.

[0035] FIG. 3 is an explanatory diagram showing the functional configuration example of the information processing apparatus 200 according to the embodiment of the present disclosure. Hereinbelow, the functional configuration example of the information processing apparatus 200 according to the embodiment of the present disclosure will be described using FIG. 3.

[0036] As shown in FIG. 3, the information processing apparatus 200 according to the embodiment of the present disclosure is configured to include a communication unit 210, a control unit 220, a storage unit 230, and a display unit 240.

[0037] The communication unit 210 executes communication with other devices. The communication unit 210 executes communication with other devices using, for example, Bluetooth (a registered trademark), a wireless LAN, or the like. In the present embodiment, the communication unit 210 receives sensed data transmitted from the sensor device 100. Then, the communication unit 210 can supply the sensed data received from the sensor device 100 to the control unit 220 and the storage unit 230.

[0038] The control unit 220 controls operations of the information processing apparatus 200. The control unit 220 can be configured by, for example, a CPU or the like. When the control unit 220 is configured by a CPU, the CPU can be configured by an electronic circuit. In the present embodiment, the control unit 220 executes a process of analyzing a motion of the player playing golf using the sensed data received by the communication unit 210 from the sensor device 100. Further, in the present embodiment, the control unit 220 executes a process of presenting a result of the analysis of the motion of the player playing golf on the display unit 240.

- [0039] The control unit 220 computes absolute positions of the sensor devices 100a and 100b, and an absolute position of the head of a golf club that can be estimated from the absolute positions of the sensor devices 100a and 100b using the sensed data of the acceleration sensor. In addition, the control unit 220 successively computes a rotation matrix using sensed data of the angular velocity sensor. By successively computing the rotation matrix using the sensed data of the angular velocity sensor, the control unit 220 generates a coordinate transformation matrix from the rotation matrix, and then by transforming local coordinates of the sensor devices 100a and 100b into world coordinates using the coordinate transformation matrix, it is possible to know acceleration of the sensor devices 100a and 100b in the world coordinate system. By integrating the acceleration of the sensor devices 100a and 100b in the world coordinate system two times, the control unit 220 can obtain a trajectory of the sensor devices 100a and 100b.
- [0040] Then, the control unit 220 acquires pieces of angle information of the respective sensor devices 100a and 100b from the sensed data from the two sensor devices 100a and 100b. Then, the control unit 220 obtains the difference between the pieces of angle information of the sensor devices 100a and 100b, and thereby acquires a time-series change of the wrist joint of the player. By analyzing the sensed data from the plurality of sensor devices 100a and 100b worn by the player, the control unit 220 can obtain information of a change in a body state of the player that would otherwise be difficult to obtain with a single sensor device, for example, a time-series change of a wrist angle or the like, and present the change in the body state of the player.
- [0041] The control unit 220 can be configured to include an analysis unit 221 and an information generation unit 222. The analysis unit 221 analyzes sensed data detected by the two respective sensor devices 100a and 100b with which the player is equipped. The information generation unit 222 generates information that visualizes the figure of a change in a body state of the player based on an analysis result of the sensed data by the analysis unit 221. The information generated by the information generation unit 222 is transmitted to the display unit 240, and thereby the information processing apparatus 200 can present the information based on the sensed data detected by the respective sensor devices 100a and 100b. An example of an analysis process using the sensed data by the analysis unit 221 will be described later in detail.
- [0042] The storage unit 230 retains various kinds of information, particularly information used in processes in the control unit 220. The storage unit 230 can be configured by, for example, a ROM, a RAM, a hard disk drive (HDD), a solid-state drive (SSD), and the like. The control unit 220, for example, causes the storage unit 230 to store information. In addition, the information retained in the storage unit 230 is read by, for example, the control unit 220. Further, the storage unit 230 may retain computer

programs read and sequentially executed by the control unit 220.

[0043] The display unit 240 displays various kinds of information, particularly, information generated as a result of processes of the control unit 220. The display unit 240 can be configured as a display device, for example, a liquid crystal display, an organic EL display, or the like. In the present embodiment, the display unit 240 displays a result obtained by analyzing a motion of the player playing golf which is obtained from analysis of the sensed data in the control unit 220. An example of the result of analysis displayed by the display unit 240 will be described later. The display unit 240 may be provided with a touch panel, and a user can manipulate the information processing apparatus 200 by touching the display unit 240 with his or her finger or bringing his or her finger or the like close thereto.

[0044] Although FIG. 3 illustrates that the information processing apparatus 200 includes the display unit 240, the present disclosure is not limited thereto. The display unit 240 may be configured as a separate device from the information processing apparatus 200. In addition, the information processing apparatus 200 may include the imaging device 300 shown in the system configuration example of FIG. 1.

[0045] With the configuration shown in FIG. 3, the information processing apparatus 200 according to the embodiment of the present disclosure can analyze sensed data obtained by the sensor devices 100a and 100b and visualize and present a change in a body state of a player playing golf. In addition, by analyzing sensed data from the plurality of sensor devices 100a and 100b mounted on a player, the information processing apparatus 200 according to the embodiment of the present disclosure can obtain a change in a body state of the player that would otherwise be difficult to obtain with a single sensor device, for example, a time-series change in an angle of a wrist of the player when swinging a golf club, and thereby can present the change in the body state of the player.

[0046] The functional configuration example of the information processing apparatus 200 according to the embodiment of the present disclosure has been described above using FIG. 3. Next, an example of information displayed by the information processing apparatus 200 according to an embodiment of the present disclosure will be described.

[0047] 1.3. Information display example

FIG. 4 is an explanatory diagram showing an example of information 400 that the information processing apparatus 200 according to an embodiment of the present disclosure causes the display unit 240 to display. The information 400 shown in FIG. 4 includes various kinds of information obtained through analysis of sensed data transmitted from the sensor device 100 and a dynamic image captured by the imaging device 300. Note that the information 400 shown in FIG. 4 can be generated by the information generation unit 222.

- [0048] The information 400 shown in FIG. 4 includes swing information 410 indicating a speed of the head of a golf club which a player swings and a tempo of the swing of the golf club, trajectory information 420 indicating a trajectory of the swing of the golf club using three-dimensional modeling, dynamic image information 430 indicating a dynamic image of the player captured by the imaging device 300, graph information 440 indicating a change in the speed of the head of the golf club in a graph, wrist information 450 indicating a change in a state of a wrist of the player during the swing in an animation, a reset button 460 for causing display of a trajectory displayed in the trajectory information 420 to return to an initial state, and a retry button 470 for acquiring sensed data again and for executing analysis again.
- [0049] The swing information 410 includes the maximum value of the speed of the golf club head, a backswing time taken from an address posture and pulling back of the club to take an end-backswing position, a downswing time taken from the end-backswing position to contact, and a follow-through time taken from contact and continuation of a series of motions to a finishing posture.
- [0050] A trajectory displayed in the trajectory information 420 can be rotated in an arbitrary direction and displayed according to user manipulations. Note that display of a trajectory displayed in the trajectory information 420 returns to an initial state when a user touches the reset button 460. The trajectory displayed in the trajectory information 420 can be changed according to a selection manipulation by the user with respect to a check box 421. As a trajectory displayed in the trajectory information 420 in the present embodiment, a position of the golf club head estimated from a position of the sensor device 100, a position of the sensor device 100, and a position of the shaft of the golf club estimated from the position of the sensor device 100 can be selected.
- [0051] In addition, the information processing apparatus 200 can reproduce a dynamic image displayed in the dynamic image information 430 from a position designated in a user manipulation performed with respect to a slider bar 431.
- [0052] As shown in FIG. 4, the information processing apparatus 200 may display the trajectory displayed in the trajectory information 420, the slider bar 431, and the background color of the graph information 440 in different colors for the backswing time, the downswing time, and the follow-through time.
- [0053] The pieces of information included in the information 400 shown in FIG. 4 are based on the sensed data transmitted from the sensor devices 100a and 100b and the dynamic image captured by the imaging device 300. The swing information 410, the trajectory information 420, and the graph information 440 can be generated based on sensed data transmitted from a single sensor device 100 (for example, the sensor device 100a).
- [0054] The pieces of information included in the information 400 shown in FIG. 4 can be generated through arithmetic processing performed by the control unit 220 with respect

to sensed data and image processing performed on the dynamic image captured by the imaging device 300. Particularly, the wrist information 450 can be generated from a time-series change in an angle of the wrist of the player during the swing obtained as the control unit 220 analyzes the sensed data from the sensor devices 100a and 100b and then the difference between pieces of angle information of the sensor devices 100a and 100b is taken.

[0055] When the user instructs reproduction of the dynamic image displayed as the dynamic image information 430 to the information processing apparatus 200 through, for example, a predetermined manipulation, the information processing apparatus 200 not only outputs the dynamic image displayed as the dynamic image information 430 to the display unit 240 but also outputs other information, for example, a change in a state of the wrist of the player displayed as the wrist information 450 to the display unit 240 in synchronization with the dynamic image displayed as the dynamic image information 430. In addition, while the dynamic image displayed as the dynamic image information 430 is reproduced, a bar 441 of the graph information 440 moves in synchronization with the reproduction of the dynamic image.

[0056] By generating information for visualizing the motion of the player that serves as a foundation for the information 400 as shown in FIG. 4, the information processing apparatus 200 can present, for example, the trajectory of the hand holding the golf club during swing, and the motion of the joint during swing, particularly of the wrist of the hand holding the golf club. If the player views the information 400 as shown in FIG. 4, he or she can ascertain whether the trajectory of the swing is close to inside-out that is an ideal swing or outside-in that is not an ideal swing.

[0057] When playing golf, if the wrist turns at the time of impact during swing, the speed of the head increases. If the player views the information 400 as shown in FIG. 4, he or she can ascertain whether or not his or her wrist turns earlier than the time of impact during swing.

[0058] The example of the information that the information processing apparatus 200 displays according to the embodiment of the present disclosure has been described above using FIG. 4. Of course, it is needless to say that information displayed through the analysis processing performed with respect to sensed data transmitted from the sensor devices 100a and 100b and the image processing performed with respect to a dynamic image captured by the imaging device 300 is not limited to that shown in FIG. 4.

[0059] By presenting the information 400 as shown in FIG. 4, the information processing apparatus 200 according to an embodiment of the present disclosure can present a change in a body state of a player and information that visualizes a state of equipment (a golf club) that the player uses to the player. Viewing the information 400 that the in-

formation processing apparatus 200 presents can help the player become proficient in his or her playing techniques. In addition, viewing the information 400 that the information processing apparatus 200 can help a coach who trains the player train the player better.

[0060] 1.4. Analysis process example

Next, an analysis process example of sensed data performed by the information processing apparatus 200 according to an embodiment of the present disclosure will be described. FIGS. 5 to 7 are flowcharts showing operation examples of the information processing apparatus 200 according to the embodiment of the present disclosure. The flowcharts shown in FIGS. 5 to 7 are for the analysis process examples of sensed data performed by the information processing apparatus 200 according to the embodiment of the present disclosure. Note that a series of all processes described hereinbelow can be executed by the analysis unit 221. Hereinbelow, the operation examples of the information processing apparatus 200 according to the embodiment of the present disclosure will be described using FIGS. 5 to 7.

[0061] FIG. 5 shows the analysis process example of sensed data transmitted from the sensor device 100a performed by the information processing apparatus 200 before a player swings a golf club. Before the player swings the golf club, the acceleration sensor included in the sensor unit 140 is assumed to stand still, and when a direction of gravitational acceleration is detected, pitch and roll of the sensor device 100a are ascertained. Thus, the information processing apparatus 200 acquires acceleration data from the sensor device 100a (Step S101), detects the direction of gravitational acceleration from the acceleration data, and thereby detects pitch and roll of the sensor device 100a (Step S102).

[0062] In order to obtain a trajectory of a swing of a player, it is necessary for the information processing apparatus 200 to ascertain world coordinates of the sensor device 100a. When the pitch and roll of the sensor device 100a are ascertained, a transformation matrix for transforming local coordinates of the sensor device 100a into the world coordinates can be generated. Thus, using the pitch and roll of the sensor device 100a detected in Step S102, the information processing apparatus 200 generates initial values of a coordinate transformation matrix for transforming local coordinates of the sensor device 100a into the world coordinates (Step S103). By generating the coordinate transformation matrix, the information processing apparatus 200 can generate the world coordinates of the sensor device 100a using the sensed data transmitted from the sensor device 100a.

[0063] FIG. 6 shows the analysis process example of the sensed data transmitted from the sensor device 100a performed by the information processing apparatus 200 when the player swings the golf club. When the player swings the golf club, the information

processing apparatus 200 acquires acceleration data and angular velocity data from the sensor device 100a (Steps S111 and S112), and transforms the local coordinates of the sensor device 100a into the world coordinates using the coordinate transformation matrix obtained in the process shown in FIG. 5 (Step S113).

[0064] When the acceleration is integrated two times, the position of the sensor device is obtained. Thus, when the local coordinates of the sensor device 100a are transformed into the world coordinates in Step S113, the information processing apparatus 200 integrates the acceleration data after the transformation two times (Steps S114 and S115), and then computes the position (trajectory) of the sensor device 100a (Step S116). Further, the information processing apparatus 200 integrates the angular velocity data after the transformation (Step S117), computes an angle (Step S118), and then updates a rotation matrix (Step S119).

[0065] The information processing apparatus 200 integrates angular velocities each time sensed data is acquired from the sensor device 100a to compute angles, adds the angles, and thereby updates the rotation matrix. Then, the information processing apparatus 200 computes the coordinate transformation matrix from the updated rotation matrix (Step S120). The coordinate transformation matrix computed in Step S120 is used in the transformation process in Step S113 to transform the local coordinates of the sensor device 100a into the world coordinates.

[0066] FIG. 7 shows the analysis process example of sensed data transmitted from the sensor devices 100a and 100b performed by the information processing apparatus 200 when the player swings the golf club. By analyzing the sensed data transmitted from the two sensor devices 100a and 100b, the information processing apparatus 200 can generate data that serves as a foundation for the wrist information 450 shown in FIG. 4.

[0067] When pieces of the sensed data transmitted from the two sensor devices 100a and 100b are used, the pieces of sensed data do not arrive from the sensor devices 100a and 100b at completely the same time at all times, and thus the information processing apparatus 200 adjusts a delay of the pieces of sensed data transmitted from the sensor devices 100a and 100b (Step S121). The adjustment of a delay of Step S121 is not limited to a specific method. An example of the adjustment of a delay for sensed data will be described below.

[0068] The information processing apparatus 200 may adjust a delay based on time stamps issued to the pieces of sensed data transmitted from the respective sensor devices 100a and 100b. In addition, since the sensor devices 100a and 100b are respectively mounted on the back of a hand and near the wrist thereof, there is a high possibility of the sensed data changing in the same way. Thus, the information processing apparatus 200 may adjust a delay by causing one piece of sensed data to match the other piece of

sensed data so that the sensed data change in the same way. Of course, it is needless to say that a delay adjustment process for sensed data is not limited to these two examples.

[0069] Then, when the delay has been adjusted in Step S121, the information processing apparatus 200 successively computes a time-series change of angles (joint angles) of a joint (of the wrist in the present embodiment) using the sensed data transmitted from the sensor devices 100a and 100b (Step S122). To be specific, after adjusting the delay, the information processing apparatus 200 obtains the difference between pieces of angle information of the sensor devices 100a and 100b, and then acquires the time-series change of the joint of the wrist of the player.

[0070] By executing the series of operations described above, the information processing apparatus 200 according to the embodiment of the present disclosure can analyze the sensed data transmitted from the sensor devices 100a and 100b and generate various types of information that serve as a foundation of the information 400 as shown in FIG. 4. Thus, by executing the series of operations described above, the information processing apparatus 200 according to the embodiment of the present disclosure can generate information that visualizes the change in the body state of the player.

[0071] By analyzing the sensed data transmitted from the sensor devices 100a and 100b, the information processing apparatus 200 according to the embodiment of the present disclosure can obtain not only the information that visualizes the change in the body state of the player but also information relating to his or her play of golf. The information processing apparatus 200 may decide a time at which a value of the acceleration sensor exceeds a predetermined threshold value, for example, as an impact time at which the golf club hits a golf ball.

[0072] The information processing apparatus 200 may also set, for example, a time from when the sensor devices 100a and 100b stand still and values of sensed data start changing to when directions of the sensor devices 100a and 100b radically change in their moving states as a back-swing time, a time from when the directions of the sensor devices 100a and 100b radically change in their moving states to the impact time as a down-swing time, and a time from the impact time to when the sensor devices 100a and 100b stand still as a follow-through time. The back-swing time, the down-swing time, and the follow-through time decided in this manner can be displayed on the display unit 240 as the swing information 410 of the information 400 shown in FIG. 4.

[0073] 2. Conclusion

According to the embodiments of the present disclosure described above, the information processing system 1 in which the information processing apparatus 200 analyzes sensed data that the sensor devices 100a and 100b obtain is provided. In the information processing system 1 according to the embodiments, as the information

processing apparatus 200 analyzes the sensed data, a change in a body state of a player playing golf can be visualized and presented.

[0074] In addition, when a player is equipped with the wearable equipment on which the plurality of sensor devices 100a and 100b are installed to play golf, the information processing system 1 according to the embodiments of the present disclosure can obtain a change in a body state of the player, for example, a time-series change in angles of a wrist of the player while he or she swings a golf club that would otherwise be difficult to obtain with a single sensor device, and then can generate information that visualizes the change in the body state of the player and a state of equipment (the golf club) that the player uses. Thereby, viewing of information that the information processing apparatus 200 can help the player become proficient in his or her play.

[0075] In the embodiments described above, the case in which the sensor device 100a is installed on the glove 10 and the sensor device 100b is installed on the wrist band 20 is shown. By installing the sensor device 100a on the glove 10 and the sensor device 100b on the wrist band 20, the information processing system 1 according to the embodiments of the present disclosure can visualize motions of the joint of a wrist of the player wearing the glove 10 and the wrist band 20 using only the two sensor devices 100a and 100b. In other words, the information processing system 1 according to the embodiments of the present disclosure can present information that can contribute to proficiency in play of the player with a minimum number of sensor devices.

[0076] Although the case in which the sensor device 100a is installed on the glove 10 and the sensor device 100b is installed on the wrist band 20 is shown in the embodiments described above, the present disclosure is not limited thereto. As described above, the sensor device 100 that obtains sensed data can be installed in various positions of the head, shoulders, waist, knees, and the like of the player in which a change in a body state of the player can be obtained. For example, by mounting one near a wrist of the player and the other near the waist, the information processing system 1 can generate information that visualizes motions of the waist of the player during a swing and then visualize and present the motions of the waist of the player.

[0077] Steps in processes executed by devices in this specification are not necessarily executed chronologically in the order described in a sequence chart or a flow chart. For example, steps in processes executed by devices may be executed in a different order from the order described in a flow chart or may be executed in parallel.

[0078] Further, a computer program can be created which causes hardware such as a CPU, ROM, or RAM, incorporated in each of the devices, to function in a manner similar to that of structures in the above-described devices. Furthermore, it is possible to provide a recording medium having the computer program recorded thereon. Moreover, by configuring respective functional blocks shown in a functional block diagram as

hardware, the hardware can achieve a series of processes.

[0079] Furthermore, the information processing apparatus 200 according to the embodiments of the present disclosure may be realized as a separate device from a device provided with a display on which images are displayed as results of processes of the information processing apparatus 200 (for example, a server device connected to a device provided with a display via a network such as the Internet), or may be realized as a terminal device that receives information from a server device. In addition, a configuration of the information processing apparatus 200 according to the embodiments of the present disclosure may be realized by a single device, or may be realized by a system in which a plurality of devices are linked to each other. In such a system in which a plurality of devices are linked to each other, for example, a combination of a plurality of server devices, a combination of a server device and a terminal device, or the like can be included.

[0080] Note that software that realizes a user interface or an application shown in the above-described embodiments may be realized as a web application that is used via a network such as the Internet. Such a web application may be realized with a markup language, for example, HyperText Markup Language (HTML), Standard Generalized Markup Language (SGML), Extensible Markup Language (XML), or the like.

[0081] It should be understood by those skilled in the art that various modifications, combinations, sub-combinations and alterations may occur depending on design requirements and other factors insofar as they are within the scope of the appended claims or the equivalents thereof.

[0082] In addition, the effects described in the present specification are merely illustrative and demonstrative, and not limitative. In other words, the technology according to the present disclosure can exhibit other effects that are evident to those skilled in the art along with or instead of the effects based on the present specification.

[0083] (1) According to one embodiment, an apparatus according to the embodiment includes a communications interface configured to receive first sensed data from a first sensor attached to a user and second sensed data from a second sensor attached to a user; and

 circuitry configured to analyze the first sensed data and the second sensed data and provide a display signal that causes a display to produce first visual information regarding a motion of the user and second visual information regarding the motion of the user, the first visual information being different than the second visual information.

(2) An aspect of the apparatus of (1) is that wherein

 the first visual information includes analysis data of the motion of the user.

(3) An aspect of the apparatus of (1) and/or (2) is that wherein

 the first visual information includes a trajectory of an object swung by the user as

part of the motion of the user.

(4) An aspect of the apparatus of (1) through (3) is that wherein the first visual information includes a change in state of a body part of the user.

(5) An aspect of the apparatus of (1) through (4) is that wherein the circuitry is configured to cause the display to provide a user selectable indication that identifies a selected body part that is associated with the change in the state, and in response to a selection of the user selectable indication, the circuitry analyzes the motion of the selected body part and includes in the display signal the first visual information regarding the change in state of the selected body part.

(6) An aspect of the apparatus of (1) through (3) is that wherein the circuitry is configured to cause the display to provide a user selectable indication to reset a displayed trajectory of the object swung by the user so that another motion event can be captured, analyzed and displayed.

(7) An aspect of the apparatus of (1) through (6) is that wherein the first visualization information includes at least one of an image, a figure, a video and a picture.

(8) An aspect of the apparatus of (1) through (7) is that wherein the first visual information and the second visual information are displayed in a synchronous relationship so as to show a time-based relationship between the first visual information and the second visual information.

(9) An aspect of the apparatus of (1) through (8) is that wherein the first visual information relates to an object trajectory and the second visual information relates to a hand and/or wrist change of state of a user.

(10) An aspect of the apparatus of (1) through (9) is that wherein the object trajectory is a trajectory of a golf club or a tennis racket.

(11) According to a method embodiment, the method includes collecting first sensed data from a first sensor attached to a user and second sensed data from a second sensor attached to a user; sending via a communications interface the first sensed data and the second sensed data to analysis circuitry; and receiving from the analysis circuitry a display signal and displaying first visual information regarding a motion of the user and second visual information regarding the motion of the user, the first visual information being different than the second visual information.

(12) An aspect of the method of (11) is that wherein the first visual information includes analysis data of the motion of the user.

(13) An aspect of the method of (11) and/or (12) is that wherein the first visual information includes a trajectory of an object swung by the user as part of the motion of the user.

(14) An aspect of the method of (11) through (13) is that wherein the first visual information includes a change in state of a body part of the user.

(15) An aspect of the method of (11) through (14) is that wherein the displaying includes displaying a user selectable indication that identifies a selected body part that is associated with the change in the state, and in response to a selection of the user selectable indication, the displaying includes displaying the first visual information regarding the change in state of the selected body part.

(16) An aspect of the method of (13) through (15) is that wherein the displaying includes displaying a user selectable indication to reset a displayed trajectory of the object swung by the user so that another motion event can be captured, analyzed and displayed.

(17) An aspect of the method of (11) through (16) is that wherein the first visualization information includes at least one of an image, a figure, a video and a picture.

(18) An aspect of the method of (11) through (17) is that wherein the displaying includes displaying the first visual information and the second visual information in a synchronous relationship so as to show a time-based relationship between the first visual information and the second visual information.

(19) According to another apparatus embodiment, the apparatus includes a communications interface configured to receive first sensed data from a first sensor attached to a user and a second sensed data from a second sensor attached to a user; circuitry configured to analyze the first sensed data and the second sensed data and provide a display signal that causes a display to produce first visual information regarding a motion of the user and second visual information regarding the motion of the user, the first visual information being different than the second visual information; and the display configured to display the first visual information and the second visual information.

(20) An aspect of the apparatus of (19) is that wherein the first visual information includes analysis data of the motion of the user.

(21) An information processing apparatus including:
an analysis unit configured to analyze sensed data detected by a respective plurality of sensor devices that are mounted on a player; and
an information generation unit configured to generate information that visualizes a figure of a change in a body state of the player on which the plurality of sensor devices are mounted based on an analysis result of the analysis unit.

(22) The information processing apparatus according to (21), wherein the plurality of sensor devices are installed at positions at which a joint of the player is interposed between the plurality of sensor devices.

(23) The information processing apparatus according to (22), wherein the joint of the player is a wrist of the player, and wherein the information generation unit generates information that visualizes a figure of a change in the wrist of the player based on an analysis result of the analysis unit.

(24) The information processing apparatus according to any of (21) to (23), wherein the information generation unit generates information relating to a swing of a golf club performed by the player.

(25) An information processing method including:
analyzing sensed data detected by a respective plurality of sensor devices that are mounted on a player; and
generating information that visualizes a figure of a change in a body state of the player on which the plurality of sensor devices are mounted based on a result of the analysis.

(26) A computer program causing a computer to execute:
analyzing sensed data detected by a respective plurality of sensor devices that are mounted on a player; and
generating information that visualizes a figure of a change in a body state of the player on which the plurality of sensor devices are mounted based on a result of the analysis.

Reference Signs List

- [0084] 1 information processing system
10 glove
20 wrist band
100, 100a, 100b sensor device
110 control unit
120 battery
130 memory
140 sensor unit
150 communication unit
200 information processing apparatus
210 communication unit
220 control unit
221 analysis unit
222 information generation unit
230 storage unit
240 display unit
300 imaging device

Claims

- [Claim 1] An apparatus comprising:
a communications interface configured to receive first sensed data from a first sensor attached to a user and second sensed data from a second sensor attached to a user; and
circuitry configured to analyze the first sensed data and the second sensed data and provide a display signal that causes a display to produce first visual information regarding a motion of the user and second visual information regarding the motion of the user, the first visual information being different than the second visual information.
- [Claim 2] The apparatus of claim 1, wherein
the first visual information includes analysis data of the motion of the user.
- [Claim 3] The apparatus of claim 1, wherein
the first visual information includes a trajectory of an object swung by the user as part of the motion of the user.
- [Claim 4] The apparatus of claim 1, wherein
the first visual information includes a change in state of a body part of the user.
- [Claim 5] The apparatus of claim 4, wherein
the circuitry is configured to cause the display to provide a user selectable indication that identifies a selected body part that is associated with the change in the state, and in response to a selection of the user selectable indication, the circuitry analyzes the motion of the selected body part and includes in the display signal the first visual information regarding the change in state of the selected body part.
- [Claim 6] The apparatus of claim 3, wherein
the circuitry is configured to cause the display to provide a user selectable indication to reset a displayed trajectory of the object swung by the user so that another motion event can be captured, analyzed and displayed.
- [Claim 7] The apparatus of claim 1, wherein the first visualization information includes at least one of an image, a figure, a video and a picture.
- [Claim 8] The apparatus of claim 1, wherein the first visual information and the second visual information are displayed in a synchronous relationship so as to show a time-based relationship between the first visual information and the second visual information.

- [Claim 9] The apparatus of claim 8, wherein the first visual information relates to an object trajectory and the second visual information relates to a hand and/or wrist change of state of a user.
- [Claim 10] The apparatus of claim 9 wherein the object trajectory is a trajectory of a golf club or a tennis racket.
- [Claim 11] A method comprising:
collecting first sensed data from a first sensor attached to a user and second sensed data from a second sensor attached to a user;
sending via a communications interface the first sensed data and the second sensed data to analysis circuitry; receiving from the analysis circuitry a display signal and displaying first visual information regarding a motion of the user and second visual information regarding the motion of the user, the first visual information being different than the second visual information.
- [Claim 12] The method of claim 11, wherein the first visual information includes analysis data of the motion of the user.
- [Claim 13] The method of claim 11, wherein the first visual information includes a trajectory of an object swung by the user as part of the motion of the user.
- [Claim 14] The method of claim 11, wherein the first visual information includes a change in state of a body part of the user.
- [Claim 15] The method of claim 14, wherein the displaying includes displaying a user selectable indication that identifies a selected body part that is associated with the change in the state, and in response to a selection of the user selectable indication, the displaying includes displaying the first visual information regarding the change in state of the selected body part.
- [Claim 16] The method of claim 13, wherein the displaying includes displaying a user selectable indication to reset a displayed trajectory of the object swung by the user so that another motion event can be captured, analyzed and displayed.
- [Claim 17] The method of claim 11, wherein the first visualization information includes at least one of an image, a figure, a video and a picture.
- [Claim 18] The method of claim 11, wherein the displaying includes displaying the first visual information and the second visual information in a synchronous relationship so as to show a time-based relationship between

the first visual information and the second visual information.

[Claim 19]

An apparatus comprising:

a communications interface configured to receive first sensed data from a first sensor attached to a user and a second sensed data from a second sensor attached to a user;

circuitry configured to analyze the first sensed data and the second sensed data and provide a display signal that causes a display to produce first visual information regarding a motion of the user and second visual information regarding the motion of the user, the first visual information being different than the second visual information;

and

the display configured to display the first visual information and the second visual information.

[Claim 20]

The apparatus of claim 19, wherein the first visual information includes analysis data of the motion of the user.

[Fig. 1]

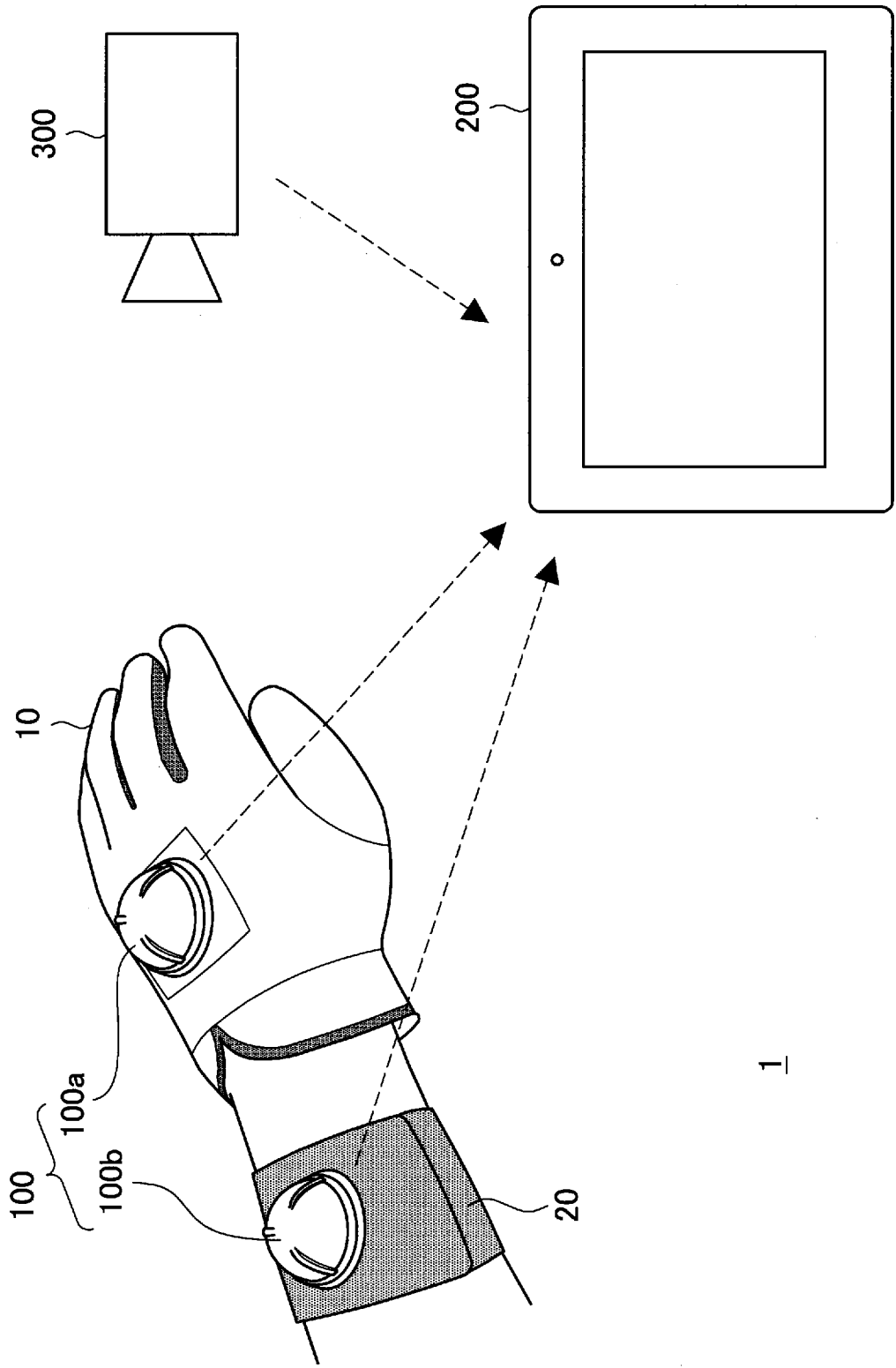

[Fig. 2]

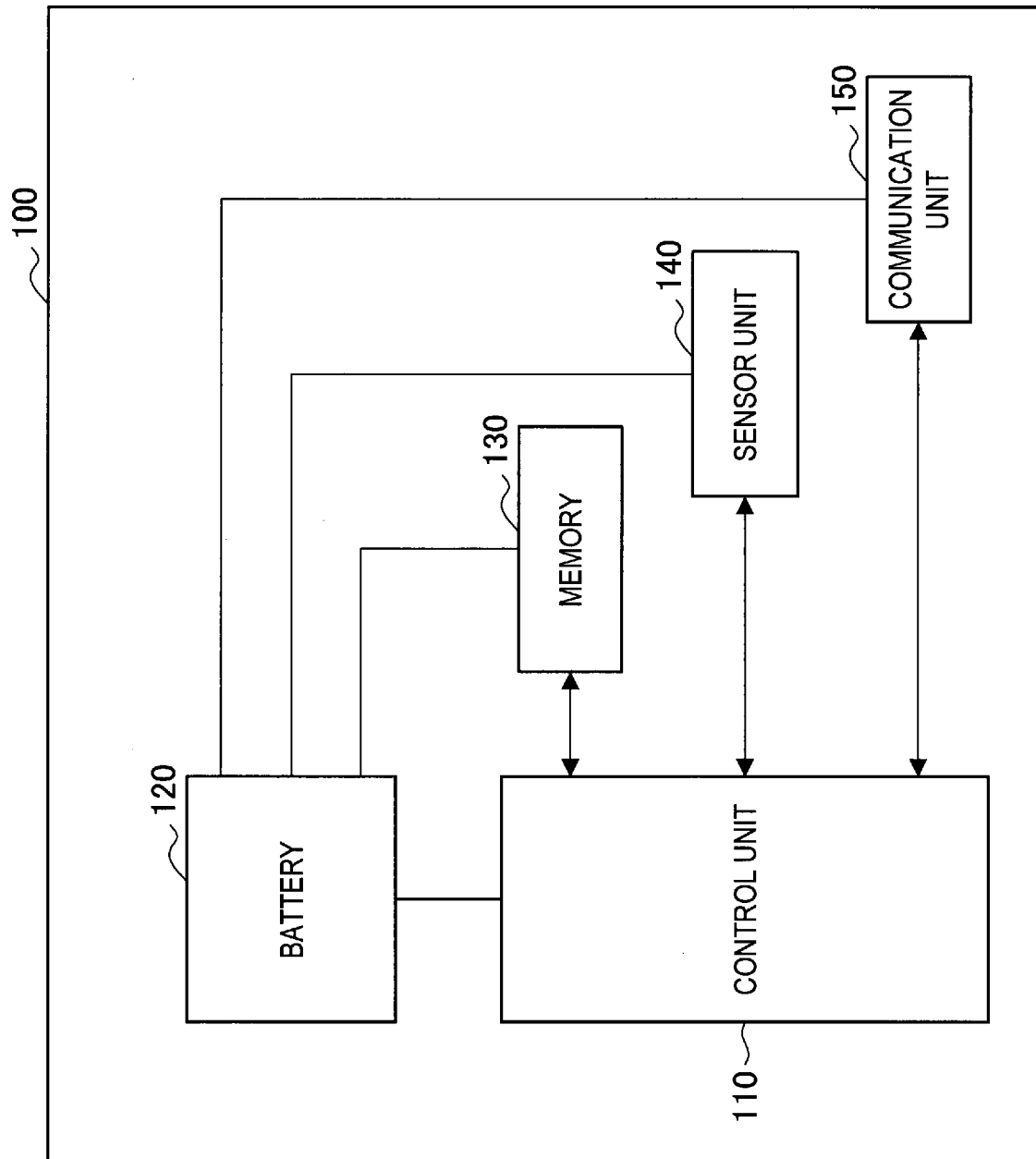

[Fig. 3]

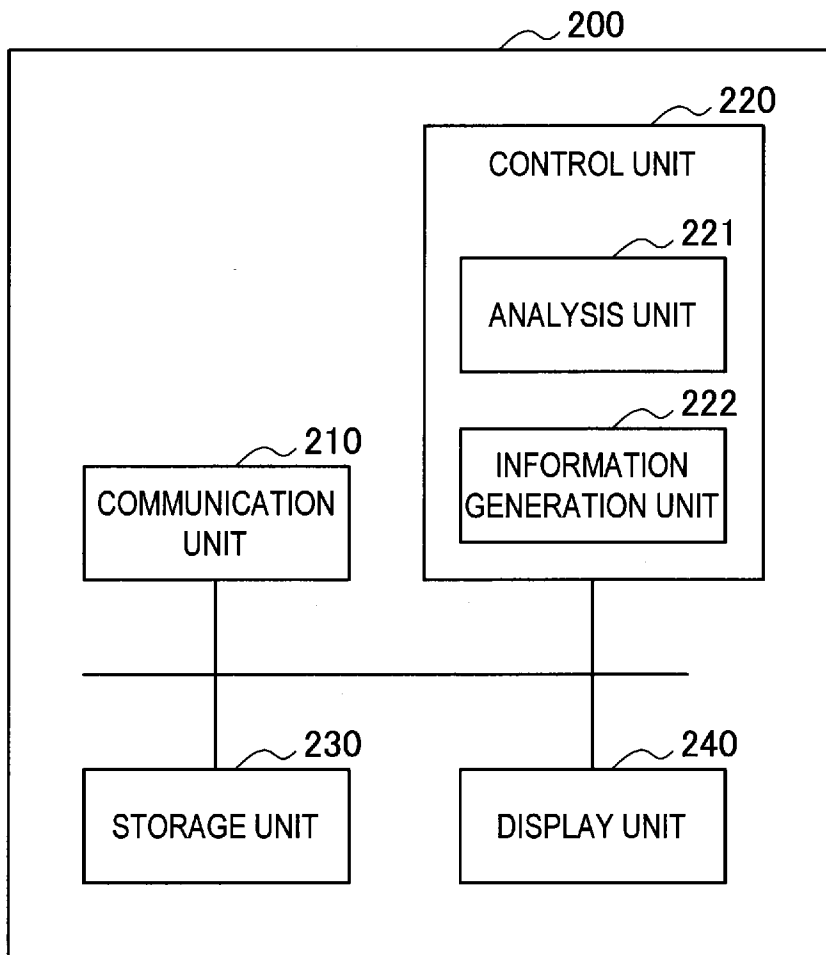

[Fig. 4]

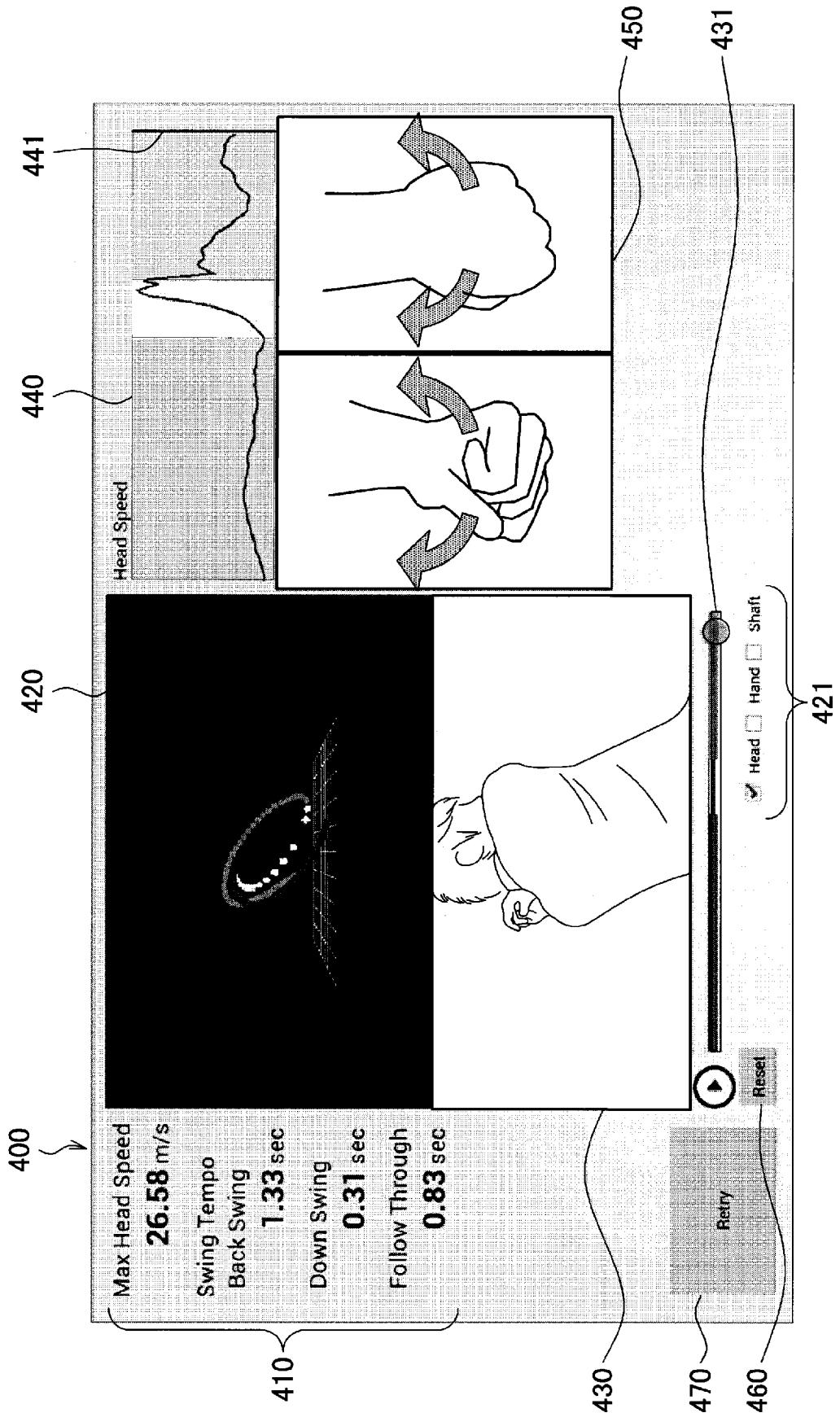

[Fig. 5]

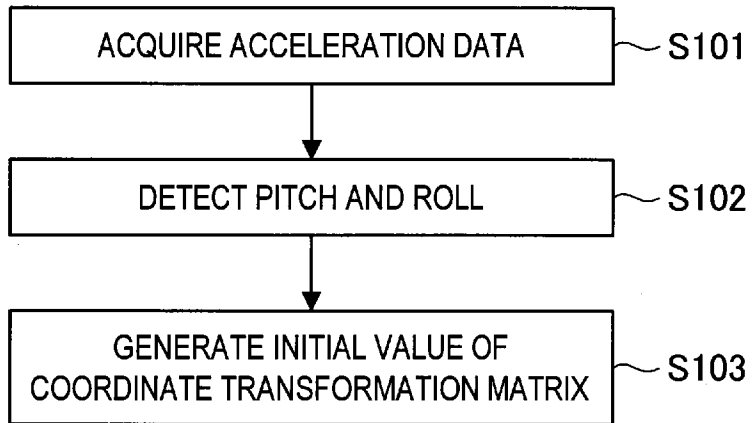

[Fig. 6]

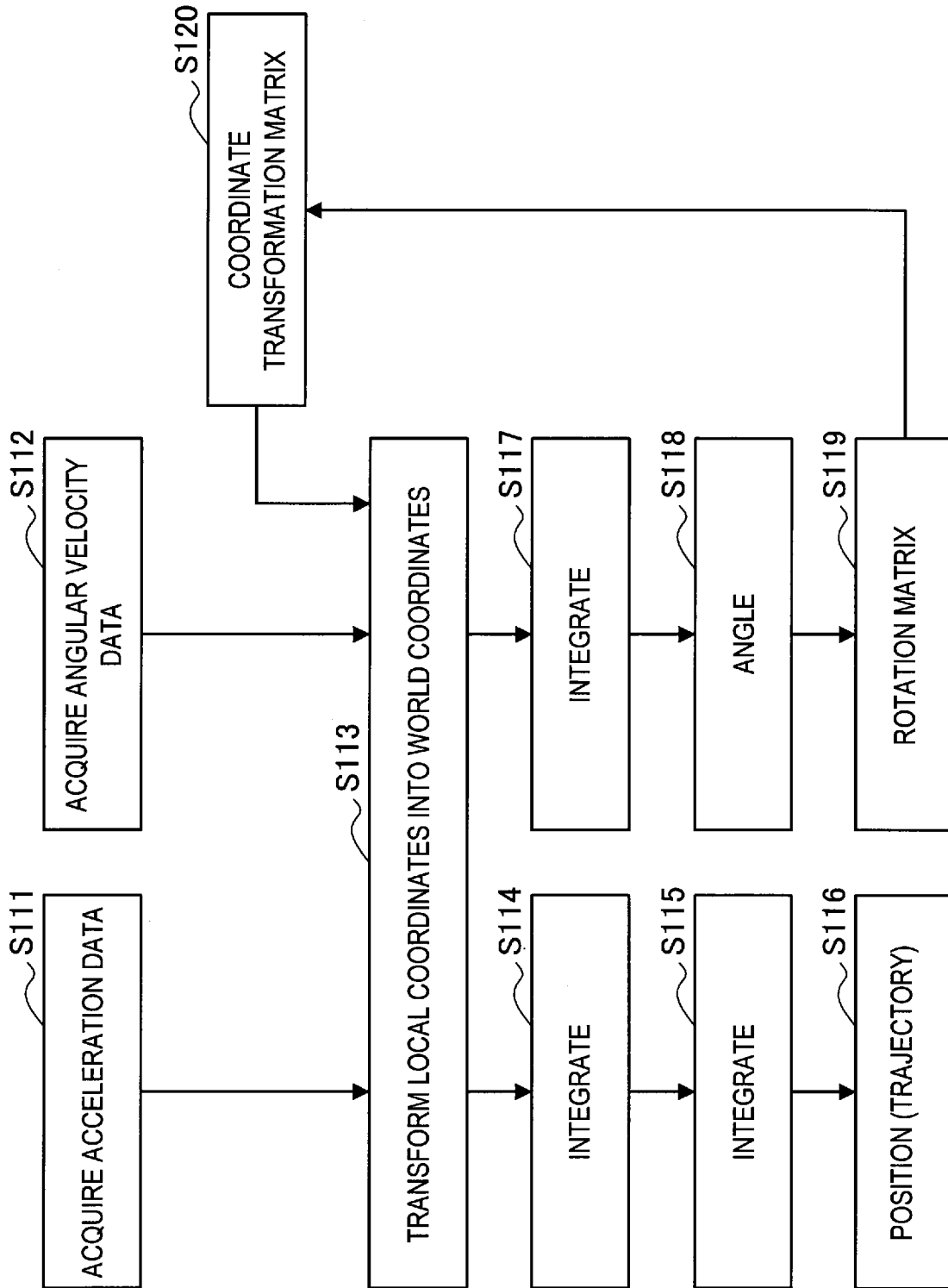

[Fig. 7]

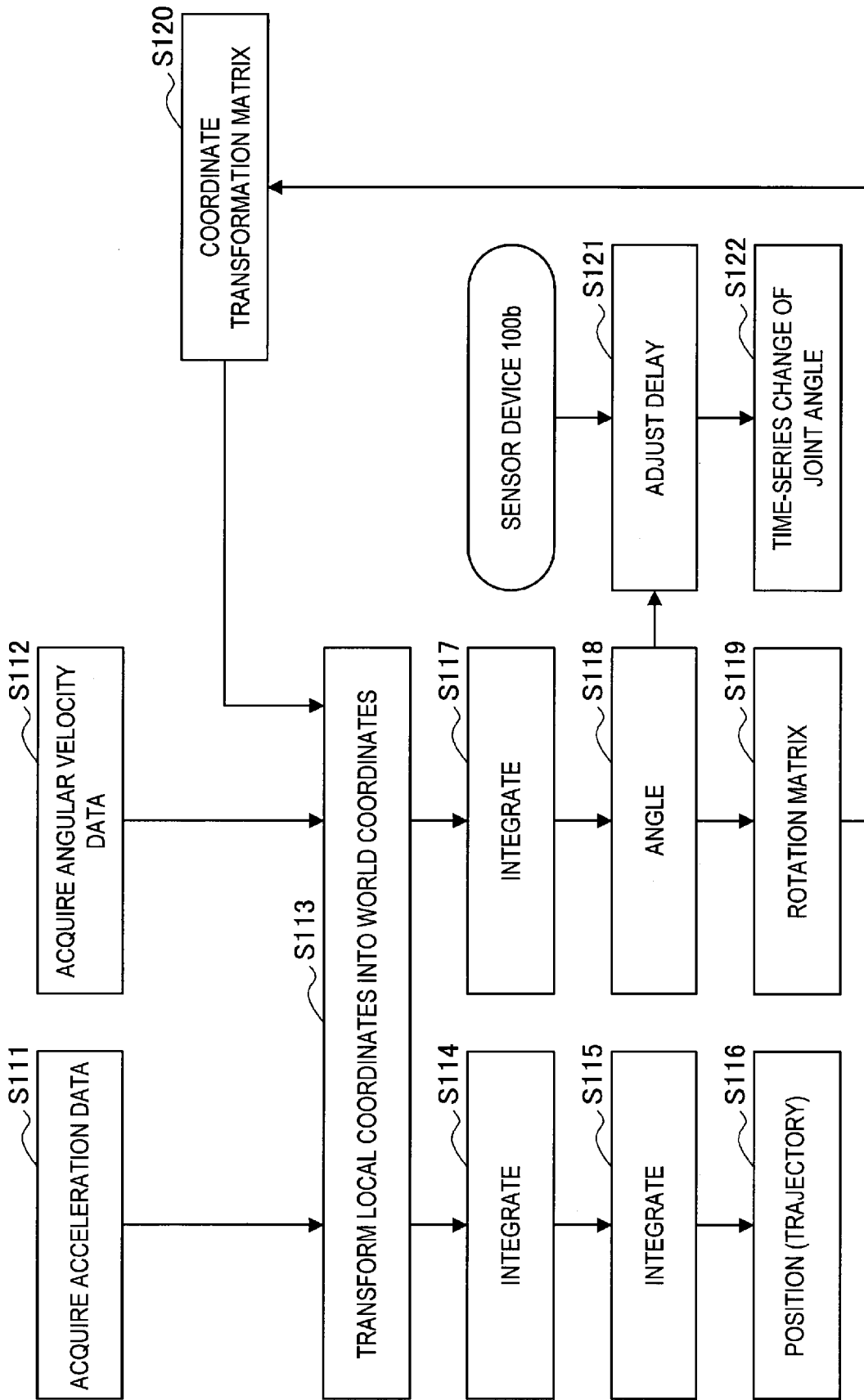

INTERNATIONAL SEARCH REPORT

International application No
PCT/JP2015/002070

A. CLASSIFICATION OF SUBJECT MATTER
INV. G09B19/00 G06K9/00
ADD.
According to International Patent Classification (IPC) or to both national classification and IPC

B. FIELDS SEARCHED
Minimum documentation searched (classification system followed by classification symbols)
G09B G06K

Documentation searched other than minimum documentation to the extent that such documents are included in the fields searched

Electronic data base consulted during the international search (name of data base and, where practicable, search terms used)
EPO-Internal

C. DOCUMENTS CONSIDERED TO BE RELEVANT

Category*	Citation of document, with indication, where appropriate, of the relevant passages	Relevant to claim No.
X	US 7 602 301 B1 (STIRLING HAROLD DAN [US] ET AL) 13 October 2009 (2009-10-13) column 9, lines 47-59 column 10, lines 1-25 column 12, lines 44-63 column 17, lines 27-38 column 20, lines 44-65 column 21, lines 21-40 column 31, lines 1-5	1-20
A	----- US 2011/276153 A1 (SELNER ALLEN JOSEPH [US]) 10 November 2011 (2011-11-10) paragraphs [0006], [0040]; claim 1; figures 1-3 -----	1-20

Further documents are listed in the continuation of Box C.

See patent family annex.

* Special categories of cited documents :

- "A" document defining the general state of the art which is not considered to be of particular relevance
- "E" earlier application or patent but published on or after the international filing date
- "L" document which may throw doubts on priority claim(s) or which is cited to establish the publication date of another citation or other special reason (as specified)
- "O" document referring to an oral disclosure, use, exhibition or other means
- "P" document published prior to the international filing date but later than the priority date claimed

- "T" later document published after the international filing date or priority date and not in conflict with the application but cited to understand the principle or theory underlying the invention
- "X" document of particular relevance; the claimed invention cannot be considered novel or cannot be considered to involve an inventive step when the document is taken alone
- "Y" document of particular relevance; the claimed invention cannot be considered to involve an inventive step when the document is combined with one or more other such documents, such combination being obvious to a person skilled in the art
- "&" document member of the same patent family

Date of the actual completion of the international search 28 July 2015	Date of mailing of the international search report 05/08/2015
---	--

Name and mailing address of the ISA/ European Patent Office, P.B. 5818 Patentlaan 2 NL - 2280 HV Rijswijk Tel. (+31-70) 340-2040, Fax: (+31-70) 340-3016	Authorized officer Beauce, Gaetan
--	--

INTERNATIONAL SEARCH REPORT

Information on patent family members

International application No

PCT/JP2015/002070

Patent document cited in search report	Publication date	Patent family member(s)	Publication date	
US 7602301	B1	13-10-2009	US 7602301 B1	13-10-2009
			US 2010117837 A1	13-05-2010
			US 2010121227 A1	13-05-2010
			US 2010121228 A1	13-05-2010
			US 2010201500 A1	12-08-2010
			US 2010201512 A1	12-08-2010
			US 2010204616 A1	12-08-2010
			US 2012143093 A1	07-06-2012

US 2011276153	A1	10-11-2011	CA 2736411 A1	06-10-2011
			US 2011276153 A1	10-11-2011
