



- (51) **International Patent Classification:**  
*E21B 17/14* (2006.01)    *E21B 7/20* (2006.01)
- (21) **International Application Number:**  
PCT/FI2012/050671
- (22) **International Filing Date:**  
28 June 2012 (28.06.2012)
- (25) **Filing Language:** Finnish
- (26) **Publication Language:** English
- (71) **Applicant (for all designated States except US):** OY AT-LAS COPCO ROTEX AB [FI/FI]; Pihtisulunkatu 1 A, FI-33330 Tampere (FI).
- (72) **Inventors; and**
- (75) **Inventors/Applicants (for US only):** GYLLING, Kai [FI/FI]; Tervasaarenkatu 5 F 26, FI-33610 Tampere (FI). VIITANEN, Kari [FI/FI]; Runkokatu 6 C 23, FI-33340 Tampere (FI).
- (74) **Agent:** KANGASMÄKI, Reijo; Finnish Patent Consulting FPC, PL 25, FI-33401 Tampere (FI).
- (81) **Designated States (unless otherwise indicated, for every kind of national protection available):** AE, AG, AL, AM,

AO, AT, AU, AZ, BA, BB, BG, BH, BR, BW, BY, BZ, CA, CH, CL, CN, CO, CR, CU, CZ, DE, DK, DM, DO, DZ, EC, EE, EG, ES, FI, GB, GD, GE, GH, GM, GT, HN, HR, HU, ID, IL, IN, IS, JP, KE, KG, KM, KN, KP, KR, KZ, LA, LC, LK, LR, LS, LT, LU, LY, MA, MD, ME, MG, MK, MN, MW, MX, MY, MZ, NA, NG, NI, NO, NZ, OM, PE, PG, PH, PL, PT, QA, RO, RS, RU, RW, SC, SD, SE, SG, SK, SL, SM, ST, SV, SY, TH, TJ, TM, TN, TR, TT, TZ, UA, UG, US, UZ, VC, VN, ZA, ZM, ZW.

(84) **Designated States (unless otherwise indicated, for every kind of regional protection available):** ARIPO (BW, GH, GM, KE, LR, LS, MW, MZ, NA, RW, SD, SL, SZ, TZ, UG, ZM, ZW), Eurasian (AM, AZ, BY, KG, KZ, RU, TJ, TM), European (AL, AT, BE, BG, CH, CY, CZ, DE, DK, EE, ES, FI, FR, GB, GR, HR, HU, IE, IS, IT, LT, LU, LV, MC, MK, MT, NL, NO, PL, PT, RO, RS, SE, SI, SK, SM, TR), OAPI (BF, BJ, CF, CG, CI, CM, GA, GN, GQ, GW, ML, MR, NE, SN, TD, TG).

**Published:**  
— with international search report (Art. 21(3))

WO 2014/001601 A1

(54) **Title:** METHOD AND APPARATUS FOR USE OF A DRILLING DEVICE MEANT FOR DOWN-THE-HOLE DRILLING

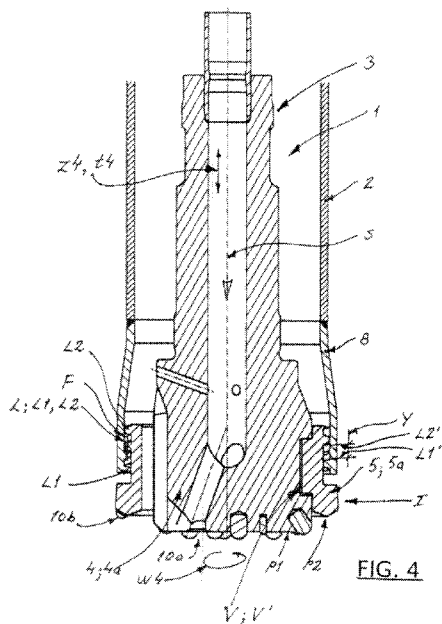

(57) **Abstract:** A method for use of a drilling device meant for down-the-hole drilling when using an apparatus, which has a drilling device (1) that consists of a casing part (2) and a drilling unit (3) that exists at least during a drilling situation essentially inside the above, which unit includes essentially rotationally symmetrical first drilling means and second drilling means (4, 5) and a casing shoe (8) for coupling of the drilling unit (3) at an end of the casing part (2). The first and the second drilling means (4, 5) of the drilling unit (3) are being coupled with each other by a counterpart surface arrangement (V) locking the same with each other immovably in opposite directions in the longitudinal direction (s). On the other hand, the binding means comprise a shoulder arrangement (L) for coupling of the casing shoe (8) with the drilling unit (3) in a non-destructive/non-formative manner and, which enables pulling of the casing part (2) into the hole to be drilled during a drilling situation essentially by means of the shoulder arrangement (L) without a need for other locking or pulling arrangements between the casing shoe (8) and the drilling unit (3). The invention also relates to an apparatus operating according to the method.

Method and apparatus for use of a drilling device meant for down-the-hole drilling

5 The invention relates to a method and apparatus for use of a drilling device meant for down-the-hole drilling according to the preambles of the independent claims related thereto.

10 A way to carry out earth drilling in a more developed manner compared to prior art is formerly known e.g. from Finnish Patent No. 95618. A drilling head in a drilling unit of the drilling apparatus presented in this patent, existing inside a casing part or in other words a so called earth pipe or casing pipe, is formed  
15 of a first frame part and an annular second frame part, the drilling surfaces of which being provided with drilling organs, such as drill bits or like, of the first and second drilling means or in other words of a center drill or a pilot and a reamer. In this solution  
20 the first frame part forming the first drilling means, is being released from the second frame part forming the reamer, in order to pull the same alone off from a drilled hole after the drilling situation. In the solution in question, the second organs of the flushing  
25 means for removal of drilling waste being generated are arranged to lead drilling waste by means of an assembly, which locks the said drilling means together for a drilling situation unrotatively in respect with each other and in both directions longitudinally, which is  
30 in other words carried out as an advantageous embodiment by loosening grooves of a bayonet coupling, being placed longitudinally on a side surface of the first frame part.

35 In connection with the drilling device described above, a casing shoe is being used at the end of the casing part, by means of which the casing part is pulled into the hole to be drilled by a power influence that is

directed to the casing shoe either from the pilot or the reamer. E.g. in figure 3 presenting prior art, the power influence pulling the casing part into the hole is transmitted by counterparts in the casing shoe and the pilot. In the implementation in question, there has been exploited furthermore screw joint principle in the binding means connecting the casing shoe and the reamer in a way that the parts in question can be coupled with each other in a lockable manner in the longitudinal direction by a screw joint, whereby the parts in question stay axially together though the mutual bayonet locking between the pilot and the reamer is opened. In figures 1 and 2 there has been presented for its part structures, in which the casing part is being pulled through binding means between the casing shoe and the reamer that is by one two or in the longitudinal direction pulling shoulder assemblies one after the other in the parts in question.

Furthermore e.g. from patent EP 1144797 it is known to exploit a so called shrinking method in forming of the binding means between a casing shoe and a rotationally symmetrical drill, in which case the casing shoe is being pressed radially in a way that a locking projection therein gets coupled with a corresponding locking recess in the drill. This kind of a mounting requires high power in order to carry out the press binding. Thus, exploitation of the method in question requires expensive machinery in coupling of the casing shoe and the drill that is to be carried out as a separate working phase. On the other hand, the method in question is applicable usually for coupling of structures, having a maximum outer diameter of 300 mm, which is why it has a proportionately limited operating scale in practice.

Putting together of the binding means according to figure 1 takes place typically so that an essentially

elongated, in a manner of speaking sleeve-like, casing shoe is being cut during a mounting phase in a machine shop longitudinally at one point and spread open, whereafter it is furthermore pressed together over the reamer. After this, it is being welded by its cutting point back to form once again as a uniform ring. The most remarkable disadvantage of this kind of a structure, being welded together, is the weak point due to the welding seam in the casing shoe, which gets very easily broken under difficult circumstances. An other disadvantage of this solution is the fact that the casing shoe must first of all be pressed onto the reamer and welded together at a machine shop. The drilling device according to figure 2 is being put together by the shrinking method that is by pressing and the one shown in figure 3 by screw joint binding, in which case the screw joint does not, however, carry load during drilling.

Particularly for the part of the drilling device of the type described above, having a rotationally symmetrical pilot and reamer, there has been found a need for further development of the construction particularly for the part of the coupling of the casing shoe, because the type of solutions described above require either preparatory coupling of the casing shoe and the drilling unit at a machine shop or rather demanding and laborious mounting measures at a working site, when keeping in mind particularly the difficulty in welding of the casing shoe, the same being manufactured usually from tempered steel.

It is an aim of the method and apparatus according to the present invention to achieve a decisive improvement in the putting together of especially the type of a drilling device described above and thus to raise essentially the level of prior art. In order to carry out this aim, the method and apparatus according to the

invention are mainly characterized by what has been presented in the characterizing parts of the independent claims related thereto.

5 As the most important advantages of the method and apparatus according to the invention may be mentioned simplicity of the constructions and operating principles enabled by the same first of all thanks to the fact that the functioning of a rotationally symmetrical  
10 drilling device that has already been found technically very well functionable as such in practice may further be enhanced by minimizing particularly measures related to putting together of the drilling unit at a machine shop. The above is thanks to the fact that the casing  
15 shoe needs not be coupled preparatively with the drilling unit at a machine shop, but instead the casing shoe can be coupled therewith easily at a working site thanks to e.g. a screw joint coupling, being exploited as an advantageous embodiment in the binding means.  
20 After this, the casing shoe being coupled e.g. with a reamer, can be furthermore coupled at the working site usually with traditional joint welding at the end of the casing part. In this case a shoulder arrangement operating as the binding means comprises counterparts  
25 in the casing shoe and the reamer, by means of which the parts in question are being coupled with each other in a locked manner in the longitudinal direction by rotating the same in respect with each other in a transverse plane with respect to the longitudinal di-  
30 rection, for making possible pulling of the casing part during a drilling situation by the casing shoe by a power influence that is transmitted to its counterpart from the counterpart in the reamer. In this case the casing shoe and the reamer are being coupled with each  
35 other as an advantageous embodiment furthermore in a way that after the longitudinal locking thereof, there will remain on the first hand a clearance in the longitudinal direction between the innermost counterpart

surfaces of the counterparts thereof, which enables a free mutual rotative motion of the said parts and, wherein on the other hand a power influence pulling the casing part into the hole is being directed during a drilling situation by the said counterpart surfaces.

Thanks to the invention in the coupling between the casing shoe and the drilling unit use of high power is thus not required nor welding, which is why separate working phases are thus not needed, either, nor massive apparatuses. Thanks to the invention it is possible to couple the casing shoe with the drilling unit, such as the reamer, extremely quickly without extra work phases or use of external power also with large dimensioned drill constructions. Thanks to the fact that in the coupling between the casing shoe and e.g. the reamer first of all deformation is not been exploited nor welding for that matter, it is possible to get the parts in question manufactured already in the machine shop production thereof into optimum measures in a way that reliable functionings of the drilling device are made sure in every respect e.g. both in the longitudinal coupling between the reamer and the pilot and in the functioning thereof during a drilling situation together with the casing part.

Other advantageous embodiments of the method and apparatus according to the invention have been presented in the dependent claims related thereto.

In the following description the invention is illustrated in detail with reference to the appended drawings, in which,

in figure 1

is shown as a longitudinal cross-sectional view one advantageous implementation according to prior art, in which mutual binding

means between the casing shoe and the reamer are arranged by successive pulling shoulders in the longitudinal direction in the parts in question,

5

in figure 2

is shown as a longitudinal cross-sectional view an implementation according to prior art, in which the binding means between the casing shoe and the reamer are carried out by one mutual pulling shoulder in the parts in question,

10

in figure 3

is shown as a longitudinal cross-sectional view an implementation according to prior art, in which the binding means between the casing shoe and the reamer are carried out by a screw joint and, in which pulling of the casing part into the hole takes place by a mutual pulling shoulder between the pilot and the casing shoe, and

15

20

in figure 4

is shown as a longitudinal cross-sectional view an advantageous drilling unit to be used by the method according to the invention.

25

30

35

The invention relates first of all to a method for use of a drilling device meant for down-the-hole drilling when using an apparatus, which has a drilling device 1 that consists of a casing part 2 and a drilling unit 3 that exists at least during a drilling situation essentially inside the above. The drilling unit includes: a drilling arrangement at a drilling head I thereof, such as first drilling means 4 for drilling a center hole and second drilling means 5 for reaming the center hole for the casing part 2, whereby the essentially rota-

tionally symmetrical first drilling means and second drilling means 4, 5 are coupled mutually at least during a drilling situation on the first hand in a power transmitting manner in order to carry out cooperation thereof for a rotational motion  $w_4$ , a feeding motion  $z_4$  and/or a hammering motion  $t_4$  and on the other hand removably in order to enable removal of the first drilling means from a drilled hole and, whereby the casing part 2 is arranged to be pulled into the hole to be drilled by the drilling unit 3; and a casing shoe 8 for coupling of the drilling unit 3 at an end of the casing part 2 by binding means that enable rotative motion of the drilling unit 3 in respect with the above and that limit mutual longitudinal movement of the said parts in opposite directions in the longitudinal direction  $s$ . The first and the second drilling means 4, 5 of the drilling unit 3 are first of all being coupled with each other by a counterpart surface arrangement  $V$  that locks the same with each other immovably in opposite directions in the longitudinal direction  $s$ . On the other hand the casing shoe 8 is being coupled with the drilling unit 3 in a non-destructive/non-formative manner by a shoulder arrangement  $L$  belonging to the binding means, which enables pulling of the casing part 2 into the hole to be drilled during a drilling situation essentially by means of the shoulder arrangement  $L$  without a need for other locking or pulling arrangements between the casing shoe 8 and the drilling unit 3.

As an advantageous embodiment of the method it is being exploited when applying an apparatus, in which the drilling head  $I$  of the drilling unit 3 is formed of a first frame part 4a and a second frame part 5a, wherein drilling surfaces  $P_1$ ,  $P_2$  formed of end surfaces of the above frame parts are provided with drilling organs of the first and the second drilling means 4, 5, such as an integrated drilling part, separate drilling pieces,

bits or like. As an advantageous embodiment, introducing of a flushing medium is enabled first of all by a first flow arrangement 6a of a flushing flow arrangement 6 for carrying out the drilling and on the other hand removal of the flushing medium and drilling waste getting generated is enabled inside the casing part 2 by a second flow arrangement 6b of the flushing flow arrangement 6. First of all the counterpart surface arrangement V for coupling of the first and the second frame parts 4a, 5a with each other is being arranged advantageously on bayonet-principle V' or in a corresponding manner. On the other hand the casing shoe 8 and the second drilling means 5, such as the second frame part 5a, are being coupled with each other by counterparts L1, L2, existing in connection with the said parts 8, 5;5a and belonging to the shoulder arrangement L, in order to couple the said parts 8, 5;5a with each other in a locked manner in the longitudinal direction s by rotating the same in respect with each other in a transverse plane with respect to the longitudinal direction s, for pulling of the casing part 2 during a drilling situation by the casing shoe 8 by a power influence F that is transmitted to its counterpart L1 from the counterpart L2 in the second drilling means 5, such as in the second frame part 5a.

Furthermore as an advantageous embodiment of the method according to the invention, the casing shoe 8 and the second drilling means 5, such as the second frame part 5a, are being coupled with each other so, that after the longitudinal s locking of the casing shoe 8 and the second drilling means 5; 5a, there will remain on the first hand a clearance Y in the longitudinal direction s between the innermost counterpart surfaces L1', L2' of the counterparts L1, L2 thereof, which enables a free mutual rotative motion of the parts in question and, wherein on the other hand the power influence F pulling the casing part 2 into the hole is being direc-

ted during a drilling situation by the said counterpart surfaces L1', L2'.

5 As a further advantageous embodiment of the method according to the invention, the counterparts L1, L2 of the shoulder arrangement L are being coupled together on screw joint principle, such as by trapezoidal, rounded, flat threads or like, being essentially symmetrical and operating with side surfaces lying in an essentially perpendicular plane with respect to the longitudinal direction.

10

The invention also relates to an apparatus for use of a drilling device meant for down-the-hole drilling as described above, which has a drilling device 1 that consists of a casing part 2 and a drilling unit 3 that includes a drilling arrangement such as preferably essentially rotationally symmetrical first drilling means 4, such as a pilot, and second drilling means 5, such as a reamer, and a casing shoe 8 for coupling of the drilling unit 3 at an end of the casing part 2 by binding means that enable rotative motion of the drilling unit 3 in respect with the above and that limit mutual longitudinal movement of the said parts in opposite directions in the longitudinal direction s. The drilling device 3 is on the other hand provided with a counterpart surface arrangement V for coupling of the first and the second drilling means 4, 5 of the drilling unit 3 with each other by getting the same locked with each other immovably in opposite directions in the longitudinal direction s. On the other hand, the binding means belonging to the drilling device 1 comprise e.g. with reference to the advantageous embodiment shown in figure 4 a shoulder arrangement L, by means of which the casing shoe 8 is couplable with the drilling unit 3 in a non-destructive/non-formative manner and, which enables pulling of the casing part 2 into the hole to be drilled during a drilling situation essen-

15

20

25

30

35

tially by means of the shoulder arrangement L without a need for other locking or pulling arrangements between the parts in question.

5 As an advantageous embodiment of the apparatus, the counterpart surface arrangement V in the drilling device 1 for coupling of the first and the second frame parts 4a, 5a with each other is on the first hand arranged on bayonet-principle V' or in a corresponding  
10 manner. On the other hand the shoulder arrangement L belonging to the drilling device 1 comprises in the embodiment according to figure 4 advantageously counterparts L1, L2 in connection with the casing shoe 8 and the second drilling means 5, such as the second  
15 frame part 5a, in the first hand for coupling of the said parts 8, 5;5a with each other in a locked manner in the longitudinal direction s by rotating the same in respect with each other in a transverse plane with respect to the longitudinal direction s, and on the  
20 other hand for pulling of the casing part 2 during a drilling situation by the casing shoe 8 by a power influence F that is transmitted to its counterpart L1 from the counterpart L2 in the second drilling means 5, such as in the second frame part 5a.

25 As a further advantageous embodiment of the apparatus, the casing shoe 8 and the second drilling means 5, such as the second frame part 5a, are coupled with each other so, that after the longitudinal s locking of the  
30 casing shoe 8 and the second drilling means 5; 5a, there will remain on the first hand a clearance Y in the longitudinal direction s between the innermost counterpart surfaces L1', L2' of the counterparts L1, L2 thereof, which enables a free mutual rotative motion  
35 of the said parts and, wherein on the other hand the power influence F that pulls the casing part 2 into the hole is directed during a drilling situation by the said counterpart surfaces L1', L2'.

As a further advantageous embodiment of the apparatus, the counterparts L1, L2 of the shoulder arrangement L are arranged to be coupled together on screw joint principle, such as by trapezoidal, rounded, flat threads or like, being essentially symmetrical and operating with side surfaces lying in an essentially perpendicular plane with respect to the longitudinal direction. In this context a screw profile is most advantageously being exploited with a proportionally high pitch. It is also naturally possible to use a screw profile with e.g. two or several ends.

As a further advantageous embodiment of the apparatus, the shoulder arrangement L comprises counterparts L1, L2 that continue uninterruptedly in an essentially perpendicular transverse plane with respect to the longitudinal direction s. The counterparts, continuing uniformly both in the casing shoe and in the reamer, transmit power between the parts in question by surface loads as optimum as possible with respect to a so called asymmetric solution, in which either one of the counterparts is carried out by one or multiple single "tooth" or in a corresponding manner.

In this case as a further advantageous manner, the mutual rotational locking movement of the counterparts L1, L2 is essentially greater than the rotational movement in the opposite direction for releasing of the counterpart surface arrangement V that locks the first and the second drilling means 4, 5 with each other. In this way it is made sure that e.g. rather soon after coupling of the reamer and the casing shoe, the parts may not get separated from each other, though the reamer and the pilot were separated from each other by a rotational movement in the opposite direction that opens the bayonet locking coupling the same. When the drilling device is being used over a longer period of time, it is possible by using suitable constructions to

get the power transmitting innermost counterpart surfaces of the counterparts so to say upset mutually in a way that the parts are not anymore separable from each other.

5

It is clear that the invention is not limited to the embodiments presented or described above, but instead it can be modified within the basic idea of the invention according to the needs at any given time. It is thus clear that the constructions of the drilling heads being illustrated in the appended drawings may vary in practice very much merely when being carried out with differing diameters. Instead of the type of embodiments shown in the appended drawings, it is naturally possible to use as the drilling device also other drilling devices that are applicable for the same purpose, in which a casing part without a casing shoe or by transmission thereof is being exploited in connection with the drilling, so that it is most advantageously not rotated when being drawn into the ground. It is not that significant for the method and the apparatus according to the invention, either, how the coupling arrangement between the first and second drilling means is carried out, wherein most heterogeneous solutions can be exploited as the power transmission assemblies between the same starting from a screw joint locking, which is possible especially thanks to the "external" functioning with respect to the fastening arrangement of the flushing flow. The invention is naturally applicable for use of a one part drilling device, which thus does not have separate reamer and pilot.

10

15

20

25

30

Claims:

1. Method for use of a drilling device meant for down-the-hole drilling when using an apparatus, which  
5 has a drilling device (1) that consists of a casing part (2) and a drilling unit (3) that exists at least during a drilling situation essentially inside the above, which unit includes: a drilling arrangement at a drilling head (I) thereof, such as first drilling  
10 means (4) for drilling a center hole and second drilling means (5) for reaming the center hole for the casing part (2), whereby the essentially rotationally symmetrical first drilling means and second drilling means (4, 5) are coupled mutually at least during a  
15 drilling situation on the first hand in a power transmitting manner in order to carry out cooperation thereof for a rotational motion (w4), a feeding motion (z4) and/or a hammering motion (t4) and on the other hand removably in order to enable removal of the first drilling  
20 means from a drilled hole and, whereby the casing part (2) is arranged to be pulled into the hole to be drilled by the drilling unit (3); and a casing shoe (8) for coupling of the drilling unit (3) at an end of the casing part (2) by binding means that enable rotative  
25 motion of the drilling unit (3) in respect with the above and that limit mutual longitudinal movement of the said parts in opposite directions in the longitudinal direction (s), **characterized** in that, the first and the second drilling means (4, 5) of the drilling  
30 unit (3) are being coupled with each other by a counterpart surface arrangement (V) that locks the same with each other immovably in opposite directions in the longitudinal direction (s) and in that, the casing shoe (8) is being coupled with the drilling unit (3) in a  
35 non-destructive/non-formative manner by a shoulder arrangement (L) belonging to the binding means, which enables pulling of the casing part (2) into the hole to be drilled during a drilling situation essentially by

means of the shoulder arrangement (L) without a need for other locking or pulling arrangements between the casing shoe (8) and the drilling unit (3).

5           2.           Method according to claim 1 when using a drilling apparatus, in which the drilling head (I) of the drilling unit (3) is formed of a first frame part (4a) and a second frame part (5a), wherein drilling surfaces (P1, P2) formed of end surfaces of the above frame parts are provided with drilling organs of the first and the second drilling means (4, 5), such as an integrated drilling part, separate drilling pieces, bits or like and, whereby introducing of a flushing medium is enabled first of all by a first flow arrangement (6a) of a flushing flow arrangement (6) for carrying out the drilling and on the other hand removal of the flushing medium and drilling waste getting generated is enabled inside the casing part (2) by a second flow arrangement (6b) of the flushing flow arrangement (6), **characterized** in that, the counterpart surface arrangement (V) for coupling of the first and the second frame parts (4a, 5a) with each other is being arranged on bayonet-principle (V') or in a corresponding manner and in that, the casing shoe (8) and the second drilling means (5), such as the second frame part (5a), are being coupled with each other by counterparts (L1, L2) existing in connection with the said parts (8, 5;5a) and belonging to the shoulder arrangement (L) in order to couple the said parts (8, 5;5a) with each other in a locked manner in the longitudinal direction (s) by rotating the same in respect with each other in a transverse plane with respect to the longitudinal direction (s) for pulling the casing part (2) during a drilling situation by the casing shoe (8) by a power influence (F) that is transmitted to its counterpart (L1) from the counterpart (L2) in the second drilling means (5), such as in the second frame part (5a).

3. Method according to claim 1 or 2, **characterized** in that, the casing shoe (8) and the second drilling means (5), such as the second frame part (5a), are being coupled with each other so, that after the longitudinal (s) locking of the casing shoe (8) and the  
5 second drilling means (5; 5a), there will remain on the first hand a clearance (Y) in the longitudinal direction (s) between the innermost counterpart surfaces (L1', L2') of the counterparts (L1, L2) thereof, which enables a free mutual rotative motion of the said parts  
10 and, wherein on the other hand the power influence (F) pulling the casing part (2) into the hole is being directed during a drilling situation by the said counterpart surfaces (L1', L2').

15

4. Method according to any of the preceding claims 1-3, **characterized** in that, the counterparts (L1, L2) of the shoulder arrangement (L) are being coupled together on screw joint principle, such as by  
20 trapezoidal, rounded, flat threads or like, being essentially symmetrical and operating with side surfaces lying in an essentially perpendicular plane with respect to the longitudinal direction.

25

5. Apparatus for use of a drilling device meant for down-the-hole drilling, which apparatus has a drilling device (1) that consists of a casing part (2) and a drilling unit (3) that exists at least during a drilling situation essentially inside the above, which unit  
30 includes: a drilling arrangement at a drilling head (I) thereof, such as first drilling means (4) for drilling a center hole and second drilling means (5) for reaming the center hole for the casing part (2), whereby the essentially rotationally symmetrical first drilling  
35 means and second drilling means (4, 5) are coupled mutually at least during a drilling situation on the first hand in a power transmitting manner in order to carry out cooperation thereof for a rotational motion

(w4), a feeding motion (z4) and/or a hammering motion (t4) and on the other hand removably in order to enable removal of the first drilling means from a drilled hole and, whereby the casing part (2) is arranged to be pulled into the hole to be drilled by the drilling unit (3); and a casing shoe (8) for coupling of the drilling unit (3) at an end of the casing part (2) by binding means that enable rotative motion of the drilling unit (3) in respect with the above and that limit mutual longitudinal movement of the said parts in opposite directions in the longitudinal direction (s), **characterized** in that, the drilling device (3) is provided with a counterpart surface arrangement (V) for coupling of the first and the second drilling means (4, 5) of the drilling unit (3) with each other by getting the same locked with each other immovably in opposite directions in the longitudinal direction (s) and in that, the binding means comprise a shoulder arrangement (L), by means of which the casing shoe (8) is couplable with the drilling unit (3) in a non-destructive/non-formative manner and, which enables pulling of the casing part (2) into the hole to be drilled during a drilling situation essentially by means of the shoulder arrangement (L) without a need for other locking or pulling arrangements between the casing shoe (8) and the drilling unit (3).

6. Apparatus according to claim 5, in which the drilling head (I) of the drilling unit (3) is formed of a first frame part (4a) and a second frame part (5a), wherein drilling surfaces (P1, P2) formed of end surfaces of the above frame parts are provided with drilling organs of the first and the second drilling means (4, 5), such as an integrated drilling part, separate drilling pieces, bits or like and, whereby introducing of a flushing medium is enabled first of all by a first flow arrangement (6a) of a flushing flow arrangement (6) for carrying out the drilling and on the other hand

removal of the flushing medium and drilling waste getting generated is enabled inside the casing part (2) by a second flow arrangement (6b) of the flushing flow arrangement (6), **characterized** in that, the counterpart surface arrangement (V) for coupling of the first and the second frame parts (4a, 5a) with each other is arranged on bayonet-principle (V') or in a corresponding manner and in that, the shoulder arrangement (L) comprises counterparts (L1, L2) in connection with the casing shoe (8) and the second drilling means (5), such as the second frame part (5a) in the first hand for coupling of the said parts (8, 5;5a) with each other in a locked manner in the longitudinal direction (s) by rotating the same in respect with each other in a transverse plane with respect to the longitudinal direction (s), and on the other hand for pulling of the casing part (2) during a drilling situation by the casing shoe (8) by a power influence (F) that is transmitted to its counterpart (L1) from the counterpart (L2) in the second drilling means (5), such as in the second frame part (5a).

7. Method according to claim 5 or 6, **characterized** in that, the casing shoe (8) and the second drilling means (5), such as the second frame part (5a), are coupled with each other so, that after the longitudinal (s) locking of the casing shoe (8) and the second drilling means (5; 5a), there will remain on the first hand a clearance (Y) in the longitudinal direction (s) between the innermost counterpart surfaces (L1', L2') of the counterparts (L1, L2) thereof, which enables a free mutual rotative motion of the said parts and, wherein on the other hand the power influence (F) that pulls the casing part (2) into the hole is directed during a drilling situation by the said counterpart surfaces (L1', L2').

8. Method according to any of the preceding claims 5-7, **characterized** in that, the counterparts (L1, L2) of the shoulder arrangement (L) are arranged to be coupled together on screw joint principle, such as by trapezoidal, rounded, flat threads or like, being essentially symmetrical and operating with side surfaces lying in an essentially perpendicular plane with respect to the longitudinal direction.

9. Apparatus according to any of the preceding claims 5-8, **characterized** in that, the shoulder arrangement (L) comprises counterparts (L1, L2) that continue uninterruptedly in an essentially perpendicular transverse plane with respect to the longitudinal direction (s).

10. Apparatus according to claim 8 or 9, **characterized** in that, the mutual rotational movement for locking of the counterparts (L1, L2) is essentially greater than the rotational movement in the opposite direction for releasing of the counterpart surface arrangement (V) that locks the first and the second drilling means (4, 5) with each other.

25

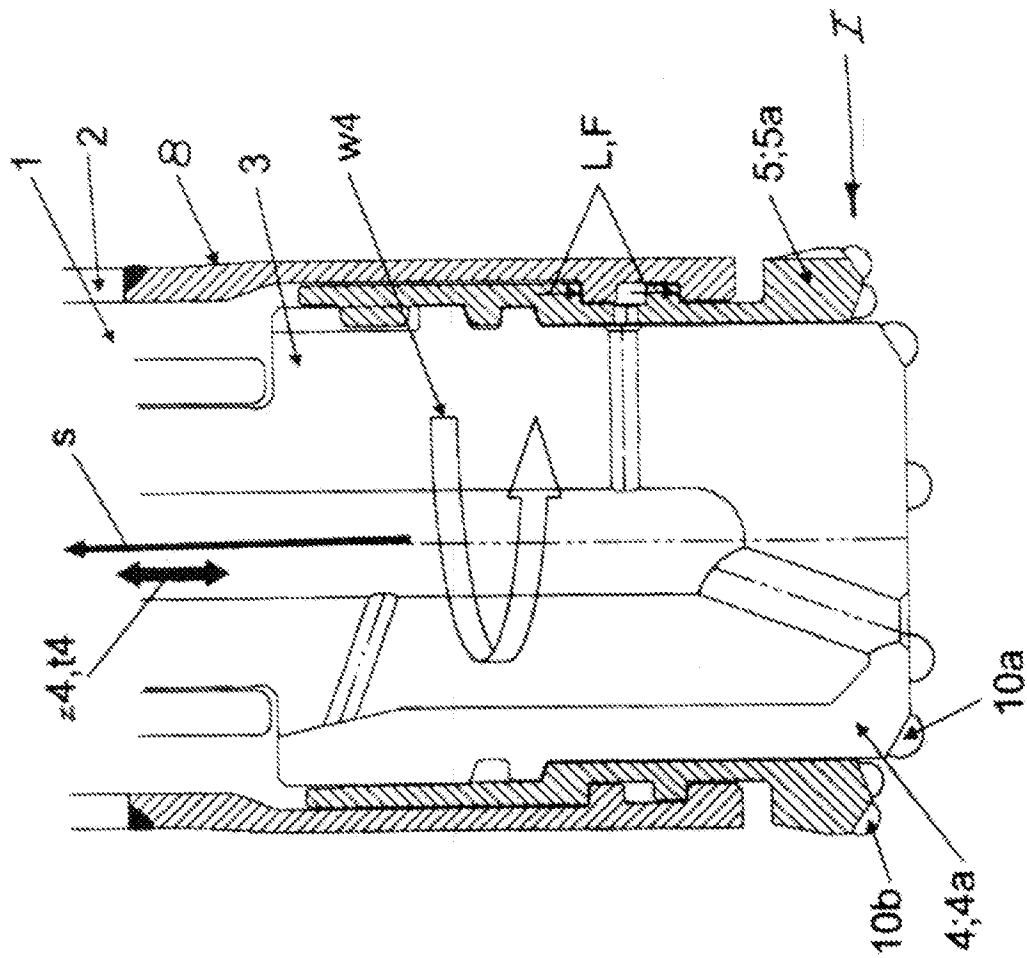

FIG. 1  
Prior art

2/4

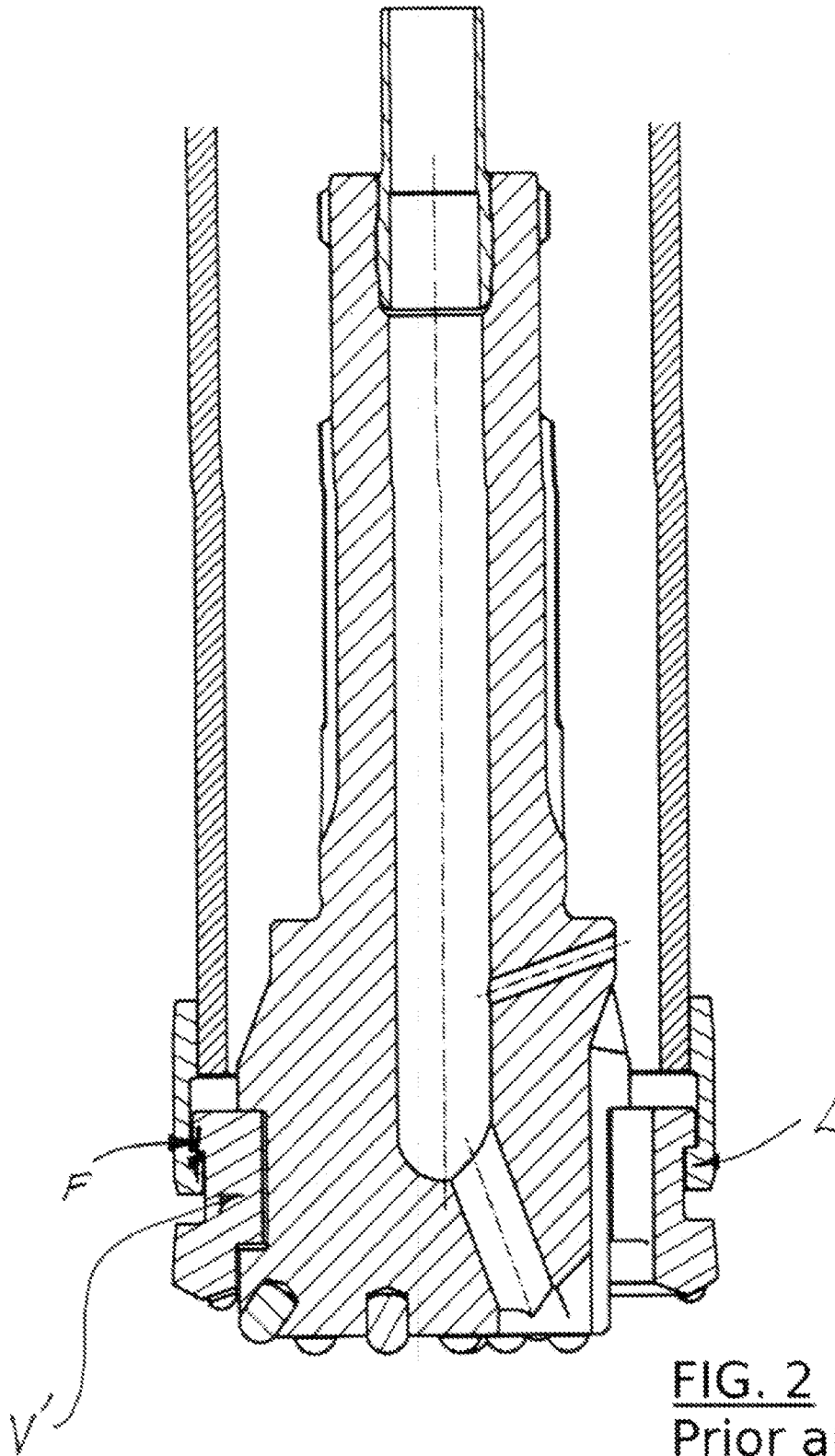
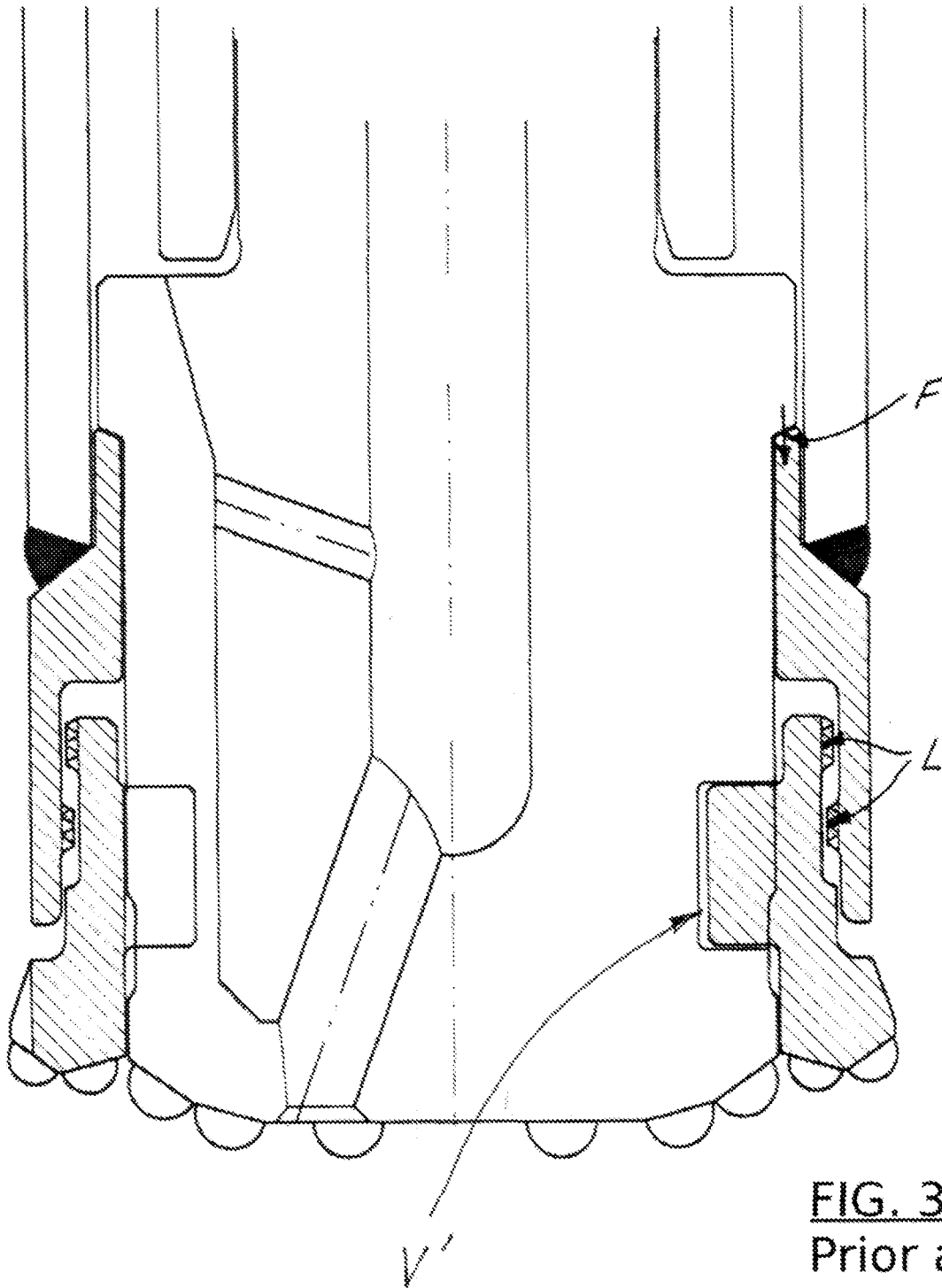

FIG. 2  
Prior art

3/4



**FIG. 3**  
Prior art



## INTERNATIONAL SEARCH REPORT

International application No.  
PCT/FI2012/050671

## A. CLASSIFICATION OF SUBJECT MATTER

IPC: see extra sheet

According to International Patent Classification (IPC) or to both national classification and IPC

## B. FIELDS SEARCHED

Minimum documentation searched (classification system followed by classification symbols)

IPC: E21B

Documentation searched other than minimum documentation to the extent that such documents are included in the fields searched

SE, DK, FI, NO classes as above

Electronic data base consulted during the international search (name of data base and, where practicable, search terms used)

EPO-Internal, PAJ, WPI data

## C. DOCUMENTS CONSIDERED TO BE RELEVANT

| Category* | Citation of document, with indication, where appropriate, of the relevant passages   | Relevant to claim No. |
|-----------|--|-----------------------|
| X         | WO 2010071563 A1 (SANDVIK INTELLECTUAL PROPERTY ET AL), 24 June 2010 (2010-06-24); page 10, line 22 - page 12, line 2; figures 15-17<br>-- | 1-3, 5-7, 9-10        |
| X         | EP 1837481 A1 (MITSUBISHI MATERIALS CORP), 26 September 2007 (2007-09-26); paragraphs [0048]-[0053]; figures 3-4<br>--                     | 4, 8                  |
| A         | EP 2339109 A2 (LOEVAB AKTIEBOLAG), 29 June 2011 (2011-06-29); whole document<br>--<br>-----  | 1-10                  |

 Further documents are listed in the continuation of Box C.

See patent family annex.

\* Special categories of cited documents:

"A" document defining the general state of the art which is not considered to be of particular relevance

"E" earlier application or patent but published on or after the international filing date

"L" document which may throw doubts on priority claim(s) or which is cited to establish the publication date of another citation or other special reason (as specified)

"O" document referring to an oral disclosure, use, exhibition or other means

"P" document published prior to the international filing date but later than the priority date claimed

"T" later document published after the international filing date or priority date and not in conflict with the application but cited to understand the principle or theory underlying the invention

"X" document of particular relevance; the claimed invention cannot be considered novel or cannot be considered to involve an inventive step when the document is taken alone

"Y" document of particular relevance; the claimed invention cannot be considered to involve an inventive step when the document is combined with one or more other such documents, such combination being obvious to a person skilled in the art

"&amp;" document member of the same patent family

Date of the actual completion of the international search

13-03-2013

Date of mailing of the international search report

14-03-2013

Name and mailing address of the ISA/SE

Patent- och registreringsverket  
Box 5055  
S-102 42 STOCKHOLM  
Facsimile No. + 46 8 666 02 86

Authorized officer

Christer Bäcknert

Telephone No. + 46 8 782 25 00

**Continuation of:** second sheet

**International Patent Classification (IPC)**

*E21B 17/14* (2006.01)

*E21B 7/20* (2006.01)

**INTERNATIONAL SEARCH REPORT**

Information on patent family members

International application No.

PCT/FI2012/050671

|    |               |            |      |                 |            |
|----|---------------|------------|------|-----------------|------------|
| WO | 2010071563 A1 | 24/06/2010 | SE   | 0802615 A1      | 19/06/2010 |
|    |               |            | SE   | 533272 C2       | 03/08/2010 |
| EP | 1837481 A1    | 26/09/2007 | AT   | 447091 T        | 15/11/2009 |
|    |               |            | DE   | 602007002936 D1 | 10/12/2009 |
|    |               |            | JP   | 2007255106 A    | 04/10/2007 |
|    |               |            | JP   | 4887857 B2      | 29/02/2012 |
|    |               |            | KR   | 20070096885 A   | 02/10/2007 |
|    |               |            | TW   | 1361854 B       | 11/04/2012 |
| EP | 2339109 A2    | 29/06/2011 | NONE |                 |            |