

(19) World Intellectual Property Organization
International Bureau



(43) International Publication Date
26 September 2002 (26.09.2002)

PCT

(10) International Publication Number
WO 02/074364 A2

- (51) International Patent Classification⁷: A61M 1/36
- (21) International Application Number: PCT/US02/08542
- (22) International Filing Date: 19 March 2002 (19.03.2002)
- (25) Filing Language: English
- (26) Publication Language: English
- (30) Priority Data:
09/813,068 20 March 2001 (20.03.2001) US
- (71) Applicant: THEROX, INC [US/US]; 2400 Michelson Drive, Irvine, CA 92612-1310 (US).
- (72) Inventors: DAW, Derek, J.; 3005 Cleveland Avenue, Costa Mesa, CA 92626 (US). WILLIAM, Patterson, R.; 90 Windjammer Drive, Irvine, CA 92614 (US). MYRICK, Stephen, E.; 2826 Stephenson Place, Tustin, CA 92782

(US). CREECH, Jeffrey, L.; 4478 Via Marina, #903, Marina Del Rey, CA 90292 (US). DIVINO, JR., Vincent; 24436 Muela, Mission Viejo, CA 92692 (US). WATSON, Gregory, P.; 9 Mallorca, Laguna Niguel, CA 92677 (US). ZALESKY, Paul, J.; 20292 Harpoon Circle, Huntington Beach, CA 92646 (US).

(74) Agent: KIVINSKI, Margaret, A.; Therox, Inc., Legal Department, 2400 Michelson Drive, Irvine, CA 92612-1310 (US).

(81) Designated State (*national*): JP.

(84) Designated States (*regional*): European patent (AT, BE, CH, CY, DE, DK, ES, FI, FR, GB, GR, IE, IT, LU, MC, NL, PT, SE, TR).

Published:

— without international search report and to be republished upon receipt of that report

[Continued on next page]

(54) Title: SYSTEM FOR ENRICHING A BODILY FLUID WITH A GAS

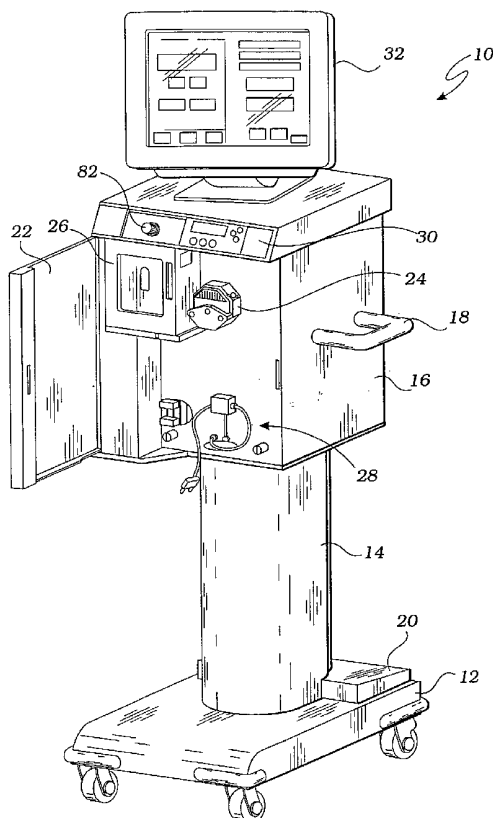

(57) Abstract: A system utilizes an oxygenation device to generate a gas-enriched physiologic fluid and to combine it with a bodily fluid to create a gas-enriched bodily fluid. The oxygenation device may take the form of a disposable cartridge, which is placed within an enclosure. An electronic controller manages various aspects of the system, such as the production of gas-enriched fluids, flow rates, bubble detection, and automatic operation and shut down.



WO 02/074364 A2



For two-letter codes and other abbreviations, refer to the "Guidance Notes on Codes and Abbreviations" appearing at the beginning of each regular issue of the PCT Gazette.

SYSTEM FOR ENRICHING A BODILY FLUID WITH A GAS

BACKGROUND OF THE INVENTION

1. Field Of The Invention

5 The present invention relates generally to gas-enriched fluids and, more particularly, to a system that enriches a bodily fluid with a gas.

2. Background Of The Related Art

10 This section is intended to introduce the reader to various aspects of art that may be related to various aspects of the present invention that are described and/or claimed below. This discussion is believed to be helpful in providing the reader with background information to facilitate a better understanding of the various aspects of the present invention. Accordingly, it should be understood that these statements are to be read in this light, and not as admissions of prior art.

15 Gas-enriched fluids are used in a wide variety of medical, commercial, and industrial applications. Depending upon the application, a particular type of fluid is enriched with a particular type of gas to produce a gas-enriched fluid having properties that are superior to the properties of either the gas or fluid alone for the given application. The techniques for
20 delivering gas-enriched fluids also vary dramatically, again depending upon the particular type of application for which the gas-enriched fluid is to be used.

 Many commercial and industrial applications exist. As one example, beverages may be purified with the addition of oxygen and carbonated with the addition of carbon dioxide.
25 As another example, the purification of wastewater is enhanced by the addition of oxygen to facilitate aerobic biological degradation. As yet another example, in fire extinguishers, an inert gas, such as nitrogen, carbon dioxide, or argon, may be dissolved in water or another suitable fluid to produce a gas-enriched fluid that expands on impact to extinguish a fire.

30 While the commercial and industrial applications of gas-enriched fluids are relatively well known, gas-enriched fluids are continuing to make inroads in the healthcare industry. Oxygen therapies, for instance, are becoming more popular in many areas. A broad

assortment of treatments involving oxygen, ozone, H_2O_2 , and other active oxygen supplements has gained practitioners among virtually all medical specialties. Oxygen therapies have been utilized in the treatment of various diseases, including cancer, AIDS, and Alzheimer's. Ozone therapy, for instance, has been used to treat several million people in Europe for a variety of medical conditions including excema, gangrene, cancer, stroke, hepatitis, herpes, and AIDS. Such ozone therapies have become popular in Europe because they tend to accelerate the oxygen metabolism and stimulate the release of oxygen in the bloodstream.

Oxygen is a crucial nutrient for human cells. It produces energy for healthy cell activity and acts directly against foreign toxins in the body. Indeed, cell damage may result from oxygen deprivation for even brief periods of time, and such cell damage can lead to organ dysfunction or failure. For example, heart attack and stroke victims experience blood flow obstructions or divergence that prevent oxygen in the blood from being delivered to the cells of vital tissues. Without oxygen, these tissues progressively deteriorate and, in severe cases, death may result from complete organ failure. However, even less severe cases can involve costly hospitalization, specialized treatments, and lengthy rehabilitation.

Blood oxygen levels may be described in terms of the concentration of oxygen that can be achieved in a saturated solution at a given partial pressure of oxygen (pO_2). Typically, for arterial blood, normal oxygen levels, i.e., normoxia or normoxemia, range from 90 to 110 mmHg. Hypoxemic blood, i.e., hypoxemia, is arterial blood with a pO_2 less than 90 mmHg. Hyperoxemic blood, i.e., hyperoxemia or hyperoxia, is arterial blood with a pO_2 greater than 400 mmHg, but less than 760 mmHg. Hyperbaric blood is arterial blood with a pO_2 greater than 760 mmHg. Venous blood, on the other hand, typically has a pO_2 level less than 90 mmHg. In the average adult, for example, normal venous blood oxygen levels range generally from 40 mmHg to 70 mmHg.

Blood oxygen levels also may be described in terms of hemoglobin saturation levels. For normal arterial blood, hemoglobin saturation is about 97% and varies only as pO_2 levels increase. For normal venous blood, hemoglobin saturation is about 75%. Indeed, hemoglobin is normally the primary oxygen carrying component in blood. However, oxygen

transfer takes place from the hemoglobin, through the blood plasma, and into the body's tissues. Therefore, the plasma is capable of carrying a substantial quantity of oxygen, although it does not normally do so. Thus, techniques for increasing the oxygen levels in blood primarily enhance the oxygen levels of the plasma, not the hemoglobin.

5

The techniques for increasing the oxygen level in blood are not unknown. For example, naval and recreational divers are familiar with hyperbaric chamber treatments used to combat the bends, although hyperbaric medicine is relatively uncommon for most people. Since hemoglobin is relatively saturated with oxygen, hyperbaric chamber treatments attempt to oxygenate the plasma. Such hyperoxygenation is believed to invigorate the body's white
10 blood cells, which are the cells that fight infection. Hyperbaric oxygen treatments may also be provided to patients suffering from radiation injuries. Radiation injuries usually occur in connection with treatments for cancer, where the radiation is used to kill the tumor. Unfortunately, at present, radiation treatments also injure surrounding healthy tissue as well.
15 The body keeps itself healthy by maintaining a constant flow of oxygen between cells, but radiation treatments can interrupt this flow of oxygen. Accordingly, hyperoxygenation can stimulate the growth of new cells, thus allowing the body to heal itself.

Radiation treatments are not the only type of medical therapy that can deprive cells
20 from oxygen. In patients who suffer from acute myocardial infarction, for example, if the myocardium is deprived of adequate levels of oxygenated blood for a prolonged period of time, irreversible damage to the heart can result. Where the infarction is manifested in a heart attack, the coronary arteries fail to provide adequate blood flow to the heart muscle. The treatment for acute myocardial infarction or myocardial ischemia often involves
25 performing angioplasty or stenting of vessels to compress, ablate, or otherwise treat the occlusions within the vessel walls. In an angioplasty procedure, for example, a balloon is placed into the vessel and inflated for a short period of time to increase the size of the interior of the vessel. When the balloon is deflated, the interior of the vessel will, hopefully, retain most or all of this increase in size to allow increased blood flow.

30

However, even with the successful treatment of occluded vessels, a risk of tissue injury may still exist. During percutaneous transluminal coronary angioplasty (PTCA), the

balloon inflation time is limited by the patient's tolerance to ischemia caused by the temporary blockage of blood flow through the vessel during balloon inflation. Ischemia is a condition in which the need for oxygen exceeds the supply of oxygen, and the condition may lead to cellular damage or necrosis. Reperfusion injury may also result, for example, due to
5 slow coronary reflow or no reflow following angioplasty. Furthermore, for some patients, angioplasty procedures are not an attractive option for the treatment of vessel blockages. Such patients are typically at increased risk of ischemia for reasons such as poor left ventricular function, lesion type and location, or the amount of myocardium at risk. Treatment options for such patients typically include more invasive procedures, such as
10 coronary bypass surgery.

To reduce the risk of tissue injury that may be associated with treatments of acute myocardial infarction and myocardial ischemia, it is usually desirable to deliver oxygenated blood or oxygen-enriched fluids to the tissues at risk. Tissue injury is minimized or
15 prevented by the diffusion of the dissolved oxygen from the blood to the tissue. Thus, in some cases, the treatment of acute myocardial infarction and myocardial ischemia includes perfusion of oxygenated blood or oxygen-enriched fluids. The term "perfusion" is derived from the French verb "perfuse" meaning "to pour over or through." In this context, however, perfusion refers to various techniques in which at least a portion of the patient's
20 blood is diverted into an extracorporeal circulation circuit, i.e., a circuit which provides blood circulation outside of the patient's body. Typically, the extracorporeal circuit includes an artificial organ that replaces the function of an internal organ prior to delivering the blood back to the patient. Presently, there are many artificial organs that can be placed in an extracorporeal circuit to substitute for a patient's organs. The list of artificial organs includes
25 artificial hearts (blood pumps), artificial lungs (oxygenators), artificial kidneys (hemodialysis), and artificial livers.

During PTCA, for example, the tolerable balloon inflation time may be increased by the concurrent introduction of oxygenated blood into the patient's coronary artery.
30 Increased blood oxygen levels also may cause the hypercontractility in the normally perfused left ventricular cardiac tissue to increase blood flow further through the treated coronary vessels. The infusion of oxygenated blood or oxygen-enriched fluids also may be continued

following the completion of PTCA or other procedures, such as surgery, to accelerate the reversal of ischemia and to facilitate recovery of myocardial function.

5 Conventional methods for the delivery of oxygenated blood or oxygen-enriched fluids to tissues involve the use of blood oxygenators. Such procedures generally involve withdrawing blood from a patient, circulating the blood through an oxygenator to increase blood oxygen concentration, and then delivering the blood back to the patient. There are drawbacks, however, to the use of conventional oxygenators in an extracorporeal circuit. Such systems typically are costly, complex, and difficult to operate. Often, a qualified perfusionist is required to prepare and monitor the system. A perfusionist is a skilled health professional specifically trained and educated to operate as a member of a surgical team responsible for the selection, setup, and operation of an extracorporeal circulation circuit. The perfusionist is responsible for operating the machine during surgery, monitoring the altered circulatory process closely, taking appropriate corrective action when abnormal situations arise, and keeping both the surgeon and anesthesiologist fully informed. In addition to the operation of the extracorporeal circuit during surgery, perfusionists often function in supportive roles for other medical specialties to assist in the conservation of blood and blood products during surgery and to provide long-term support for patient's circulation outside of the operating room environment. Because there are currently no techniques available to operate and monitor an extracorporeal circuit automatically, the presence of a qualified perfusionist, and the cost associated therewith, is typically required.

25 Conventional extracorporeal circuits also exhibit other drawbacks. For example, extracorporeal circuits typically have a relatively large priming volume. The priming volume is typically the volume of blood contained within the extracorporeal circuit, i.e., the total volume of blood that is outside of the patient's body at any given time. For example, it is not uncommon for the extracorporeal circuit to hold one to two liters of blood for a typical adult patient. Such large priming volumes are undesirable for many reasons. For example, in some cases a blood transfusion may be necessary to compensate for the blood temporarily lost to the extracorporeal circuit because of its large priming volume. Also, heaters often must be used to maintain the temperature of the blood at an acceptable level as it travels through the extracorporeal circuit. Further, conventional extracorporeal circuits are

relatively difficult to turn on and off. For instance, if the extracorporeal circuit is turned off, large stagnant pools of blood in the circuit might coagulate.

In addition to the drawbacks mentioned above, in extracorporeal circuits that include
5 conventional blood oxygenators, there is a relatively high risk of inflammatory cell reaction and blood coagulation due to the relatively slow blood flow rates and large blood contact surface area of the oxygenators. For example, a blood contact surface area of about one to two square meters and velocity flows of about 3 centimeters/second are not uncommon with conventional oxygenator systems. Thus, relatively aggressive anti-coagulation therapy, such
10 as heparinization, is usually required as an adjunct to using the oxygenator.

Finally, perhaps one of the greatest disadvantages to using conventional blood oxygenation systems relates to the maximum partial pressure of oxygen (pO_2) that can be imparted to the blood. Conventional blood oxygenation systems can prepare oxygen-
15 enriched blood having a partial pressure of oxygen of about 500 mmHg. Thus, blood having pO_2 levels near or above 760 mmHg, i.e., hyperbaric blood, cannot be achieved with conventional oxygenators.

It is desirable to deliver gas-enriched fluid to a patient in a manner which prevents or
20 minimizes bubble nucleation and formation upon infusion into the patient. The maximum concentration of gas achievable in a liquid is ordinarily governed by Henry's Law. At ambient temperature, the relatively low solubility of many gases, such as oxygen or nitrogen, within a liquid, such as water, produces a low concentration of the gas in the liquid. However, such low concentrations are typically not suitable for treating patients as discussed
25 above. Rather, it is advantageous to use a gas concentration within a liquid that greatly exceeds its solubility at ambient temperature. Compression of a gas and liquid mixture at a high pressure can be used to achieve a high dissolved gas concentration according to Henry's Law, but disturbance of a gas-saturated or a gas-supersaturated liquid by attempts to inject it into an environment at ambient pressure from a high pressure reservoir ordinarily results in
30 cavitation inception at or near the exit port. The rapid evolution of bubbles produced at the exit port vents much of the gas from the liquid, so that a high degree of gas-supersaturation no longer exists in the liquid at ambient pressure outside the high-pressure vessel. In

addition, the presence of bubbles in the effluent generates turbulence and impedes the flow of the effluent beyond the exit port. Furthermore, the coalescence of gas bubbles in blood vessels may tend to occlude the vessels and result in a gaseous local embolism that causes a decrease in local circulation, arterial hypoxemia, and systemic hypoxia.

5

In gas-enriched fluid therapies, such as oxygen therapies involving the use of hyperoxic or hyperbaric blood, delivery techniques are utilized to prevent or minimize the formation of cavitation nuclei so that clinically significant bubbles do not form within a patient's blood vessels. However, it should be understood that any bubbles that are produced tend to be very small in size, so that a perfusionist would typically have difficulty detecting bubble formation without the assistance of a bubble detection device. Unfortunately, known bubble detectors are ineffective for detecting bubbles in an extracorporeal circuit for the preparation and delivery of hyperoxic or hyperbaric blood. This problem results from the fact that the size and velocity of some bubbles are beyond the resolution of known bubble detectors. Therefore, micro bubbles (bubbles with diameters of about 50 micrometers to about 1000 micrometers) and some macro bubbles (bubbles with diameters greater than 1000 micrometers) may escape detection.

BRIEF DESCRIPTION OF THE DRAWINGS

The foregoing and other advantages of the invention will become apparent upon reading the following detailed description and upon reference to the drawings in which:

Fig. 1 illustrates a perspective view of an exemplary system for producing gas-enriched fluid;

25

Fig. 2 illustrates a block diagram of the system of Fig. 1;

Fig. 3 illustrates a block diagram of the host/user interface used in the system of Fig. 1;

30

Fig. 4 illustrates an exemplary display;

Fig. 5 illustrates a block diagram of a blood pump system used in the system of Fig. 1;

Fig. 6 illustrates an interlock system used in the system of Fig. 1;

Fig. 7 illustrates a top view of an oxygenation device used in the system of Fig. 1;

Fig. 8 illustrates a cross-sectional view taken along line 8-8 in Fig. 7;

Fig. 9 illustrates a bottom view of the oxygenation device used in the system of Fig. 1;

Fig. 10 illustrates a detailed view of a check valve illustrated in Fig. 8;

Fig. 11 illustrates a detailed view of a piston assembly illustrated in Fig. 8;

Fig. 12 illustrates a cross-sectional view taken along line 12-12 of Fig. 8;

Fig. 13 illustrates a detailed view of a valve assembly illustrated in Fig. 8;

Fig. 14 illustrates a cross-sectional view of the valve assembly taken along line 14-14 in Fig. 13;

Fig. 15 illustrates a detailed view of a capillary tube illustrated in Fig. 8;

Fig. 16 illustrates a detailed view of a vent valve illustrated in Fig. 8;

Fig. 17 illustrates an exploded view of the cartridge and cartridge enclosure;

Fig. 18 illustrates a front view of the cartridge receptacle of the cartridge enclosure illustrated in Fig. 1;

Fig. 19 illustrates a cross-sectional view of the cartridge enclosure taken along line 19-19 in Fig. 18;

5 Fig. 20 illustrates the front view of a door latch on the door of the cartridge enclosure;

Fig. 21 illustrates a cross-sectional view of the door latch taken along line 21-21 in Fig. 20;

10 Fig. 22 illustrates another cross-sectional view of the door latch;

Fig. 23 illustrates a detailed view of the door latch of Fig. 19;

15 Fig. 24 illustrates a cross-sectional view of the door latch including a blocking mechanism;

Fig. 25 illustrates a cross-sectional view of the locking mechanism of Fig. 24 as the latch is being closed;

20 Fig. 26 illustrates a cross-sectional view of the locking mechanism after the latch has been closed;

Fig. 27 illustrates a bottom view of the cartridge enclosure;

25 Fig. 28 illustrates a cross-sectional view taken along line 28-28 in Fig. 27 of a valve actuation device in an extended position;

Fig. 29 illustrates a cross-sectional view taken along line 28-28 in Fig. 27 of a valve actuation device in a retracted position;

30

Fig. 30 illustrates a top-view of the cartridge enclosure;

Fig. 31 illustrates a cross-sectional view taken along line 31-31 of Fig. 30 of a valve actuation device in its extended position;

5 Fig. 32 illustrates a cross-sectional view taken along line 31-31 of Fig. 30 of a valve actuation device in its retracted position;

Fig. 33 illustrates a cross-sectional view of the cartridge enclosure taken along line 33-33 in Fig. 18;

10 Fig. 34 illustrates a detailed view of an ultrasonic sensor illustrated in Fig. 33;

Fig. 35 illustrates a detailed view of an ultrasonic sensor illustrated in Fig. 33;

Fig. 36 illustrates a top view of the cartridge enclosure including gas connections;

15

Fig. 37 illustrates a cross-sectional view taken along line 37-37 in Fig. 36;

Fig. 38 illustrates a detailed view of the cross-sectional view of Fig. 37 of a gas connection in an unseated position;

20

Fig. 39 illustrates a detailed view of the cross-sectional view of Fig. 37 of a gas connection in a seated position;

Fig. 40 illustrates a partial cross-sectional view of a drive mechanism;

25

Figs. 41A and B illustrate an exploded view of the drive mechanism illustrated in Fig. 40;

Fig. 42 illustrates a cross-sectional view taken along line 42-42 in Fig. 40;

30

Fig. 43 illustrates a detailed view of the load cell illustrated in Fig. 42;

Fig. 44 illustrates an exploded view of a sensor assembly of the drive mechanism;

Fig. 45 illustrates a top partial cross-sectional view of the drive assembly;

5 Fig. 46 illustrates a cross-sectional view taken along line 46-46 of Fig. 45;

Fig. 47 illustrates a detailed view of a portion of the sensor assembly illustrated in Fig. 46;

10 Fig. 48 illustrates an exemplary sensor for use in the sensor assembly illustrated in Fig. 44;

Fig. 49 illustrates a state diagram depicting the basic operation of the system illustrated in Fig. 1;

15

Fig. 50 illustrates a block diagram of a system controller;

Fig. 51 illustrates a block diagram of a bubble detector;

20 Fig. 52 illustrates an exemplary signal transmitted by the bubble detector;

Fig. 53 illustrates an exemplary signal received by the bubble detector;

Fig. 54 illustrates a bubble sensor coupled to the return tube;

25

Fig. 55 illustrates a cross-sectional view of the return tube of Fig. 54;

Fig. 56 illustrates a schematic diagram of a system used to evaluate bubble detectors, such as the bubble detector of the present system;

30

Fig. 57 illustrates an elevated side view of an exemplary capillary tube;

Fig. 58 illustrates a side view of the capillary tube of Fig. 57 positioned within a connecting device incident to a material flow;

Fig. 59 illustrates a schematic diagram of an alternative system used to evaluate
5 bubble detectors, where the system includes a pulse dampener;

Fig. 60 illustrates a detailed view of an exemplary pulse dampener, and

Fig. 61 illustrates the output of a digital signal processor indicating the diameters of
10 bubbles detected by the bubble detector.

DESCRIPTION OF SPECIFIC EMBODIMENTS

One or more specific embodiments of the present invention will be described below. In an effort to provide a concise description of these embodiments, not all features of an
15 actual implementation are described in the specification. It should be appreciated that in the development of any such actual implementation, as in any engineering or design project, numerous implementation-specific decisions must be made to achieve the developers' specific goals, such as compliance with system-related and business-related constraints, which may vary from one implementation to another. Moreover, it should be appreciated that
20 such a development effort might be complex and time consuming, but would nevertheless be a routine undertaking of design, fabrication, and manufacture for those of ordinary skill having the benefit of this disclosure.

System Overview

25 Turning now to the drawings, and referring initially to Fig. 1, a system for preparing and delivering gas-enriched fluid is illustrated and designated by a reference numeral 10. Although the system 10 may be used to prepare a number of different types of gas-enriched fluids, in this particular example, the system 10 prepares oxygen-enriched blood. As will be described in detail herein, the system 10 is adapted to withdraw blood from a patient,
30 combine the blood with a oxygen-supersaturated physiologic fluid, and deliver the oxygen-enriched blood back to the patient.

Because the system 10 may be used during surgical procedures, it is typically sized to be placed within a normal operating room environment. Although the system 10 may be configured as a stationary device or a fixture within an operating room, it is often desirable for various surgical devices to be mobile. Accordingly, in this example, the system 10 is
5 illustrated as being coupled to a rolling base 12 via a pedestal 14. Although some of the electrical and/or mechanical components of the system 10 may be housed in the base 12 or the pedestal 14, these components will more typically be placed within a housing 16. To facilitate positioning of the system 10, a handle 18 may be coupled to the housing 16 for directing movement of the system 10, and a pedal 20 may be coupled to the base 12 for
10 raising and lowering the housing 16 on the pedestal 14 (via a rack and pinion mechanism which is not shown, for instance).

The housing 16 may include a cover, such as a hinged door 22, for protecting certain components of the system 10 that are positioned in locations external to the housing 16.
15 Components that are typically located on the exterior of the housing 16 may include a blood pump 24, a cartridge enclosure 26, as well as various control devices 28. Additional external items may include a user interface panel 30 and a display 32.

Referring now to Fig. 2, a block diagram representing various components of the
20 system 10 is illustrated. An appropriate draw tube 34, such as a cannula, catheter or introducer sheath, is inserted into an appropriate blood vessel 36 of a patient 38. Blood is drawn from the patient 38 through the draw tube 34 using the blood pump system 24. Specifically, the blood pump system 24 includes a pump 40, such as a peristaltic pump. As the peristaltic pump 40 mechanically produces waves of contraction along the flexible tube
25 34, fluid within the tube 34 is pumped in the direction of the arrow 42. As will be discussed in detail below, the blood pump system 24 includes a flow meter 46 that receives feedback from a flow probe 48. The flow probe 48 is coupled to the patient's return tube 50, such as a cannula or catheter. With this feedback, the blood pump system 24 can operate as an automatic extracorporeal circuit that can adjust the r.p.m. of the peristaltic pump 40 to
30 maintain the desired blood flow.

The draw tube 34 and/or the return tube 50 may be sub-selective catheters. The construction of the return tube 50 may be of particular importance in light of the fact that the gas-enriched bodily fluid may be gas-saturated or gas-supersaturated over at least a portion of the length of the return tube 50. Therefore, the return tube 50, in particular, is typically designed to reduce or eliminate the creation of cavitation nuclei which may cause a portion of the gas to come out of solution. For example, the length-to-internal diameter ratio of the catheter may be selected to create a relatively low pressure drop from the oxygenation device 54 to the patient 38. Typically, the catheter is sized to fit within a 6 french guide catheter. Materials such as polyethylene, PEBAX (polyetheramide), or silicone, for example, may be used in the construction of the catheter. Also, the lumen of the catheter should be relatively free of transitions that may cause the creation of cavitation nuclei. For example, a smooth lumen having no fused polymer transitions typically works well.

The blood is pumped through the draw tube 34 in the direction of the arrow 52 into an oxygenation device 54. Although various different types of oxygenation devices may be suitable for oxygenating the patient's blood prior to its return, the oxygenation device 54 in the system 10 advantageously prepares an oxygen-supersaturated physiologic fluid and combines it with the blood to enrich the blood with oxygen. Also, the oxygenation device 54 is advantageously sterile, removable, and disposable, so that after the procedure on the patient 38 has been completed, the oxygenation device 54 may be removed and replaced with another oxygenation device 54 for the next patient.

Advantages of the oxygenation device 54 will be described in great detail below. However, for the purposes of the discussion of Fig. 2, it is sufficient at this point to understand that the physiologic fluid, such as saline, is delivered from a suitable supply 56, such as an IV bag, to a first chamber 58 of the oxygenation device 54 under the control of a system controller 55. A suitable gas, such as oxygen, is delivered from a supply 60, such as a tank, to a second chamber 62 of the oxygenation device 54. Generally speaking, the physiologic fluid from the first chamber 58 is pumped into the second chamber 62 and atomized to create a oxygen-supersaturated physiologic solution. This oxygen-supersaturated physiologic solution is then delivered into a third chamber 64 of the oxygenation device 54 along with the blood from the patient 38. As the patient's blood mixes with the oxygen-

supersaturated physiologic solution, oxygen-enriched blood is created. This oxygen-enriched blood is taken from the third chamber 64 of the oxygenation device 54 by the return tube 50.

5 A host/user interface 66 of the system 10 monitors both the pressure on the draw tube 34 via a draw pressure sensor 68 and the pressure on the return tube 50 via a return pressure sensor 70. As illustrated in Fig. 6, the ends of the draw tube 34 and the return tube 50 that couple to the oxygenation device 54 are embodied in a Y-connector 71 in this example. The Y-connector 71 includes the draw pressure sensor 68 and the return pressure
10 sensor 70, which are operatively coupled to the host/user interface 66 via an electrical connector 73. The host/user interface 66 may deliver these pressure readings to the display 32 so that a user can monitor the pressures and adjust them if desired. The host/user interface 66 also receives a signal from a level sensor 72 that monitors the level of fluid within the mixing chamber 64 of the oxygenation device 54 to ensure that the oxygen-
15 supersaturated physiological solution is mixing with the patient's blood with little or no bubble formation.

 The system 10 further advantageously includes a suitable bubble detector 74. The bubble detector 74 includes a suitable bubble sensor 76 positioned at the return tube 50 to
20 detect bubbles as they pass through the return tube 50 to the patient 38. Again, as discussed in greater detail below, the bubble detector 74 receives the signals from the bubble sensor 76 and processes information regarding the nature of any bubbles that may be traveling in the oxygen-enriched blood going back to the patient 38. In this embodiment, the bubble detector 74 provides this information to the host/user interface 66 so that information
25 regarding bubbles in the effluent may be provided to the user via the display 32. The bubble detector 74 may also control or shut down the system 10 in certain circumstances as discussed in detail below.

 The system 10 also includes an interlock system 44. The interlock system 44
30 communicates with many of the components of the system 10 for various reasons. The interlock system 44 monitors the various components to ensure that the system 10 is operating within certain prescribed bounds. For example, the interlock system 44 receives

information regarding draw and return pressures from the pressure sensors 68 and 70, information regarding fluid level in the mixing chamber 64 from the level sensor 72, and information regarding the number and/or size of bubbles from the bubble detector 74, as well as other information regarding the operating states of the various components. Based on this information, the interlock system 44 can shut down the system 10 should it begin to operate outside of the prescribed bounds. For example, the interlock system 44 can engage clamps 78 and 80 on the draw tube 34 and the return tube 50, respectively, as well as disable the blood pump system 24 and the system controller 55 that controls the oxygenation device 54. While the interlock system 44 typically operates in this automatic fashion, a safety switch 82 may be provided so that a user can initiate a shutdown of the system 10 in the same fashion even if the system 10 is operating within its prescribed bounds.

The system 10 has a low priming volume relative to conventional extracorporeal circuits, typically in the range of 25 to 100 milliliters. Thus, a heater typically is not used with the system 10. However, if it is desirable to control the temperature of the incoming blood in the draw tube 34 or the outgoing gas-enriched blood in the return tube 50, an appropriate device, such as a heat exchanger, may be operatively coupled to one or both of the tubes 34 and 50. Indeed, not only may the heat exchanger (not shown) be used to warm the fluid as it travels through the system 10, it may also be used to cool the fluid. It may be desirable to cool the fluid because moderate hypothermia, around 30° C to 34° C has been shown to slow ischemic injury in myocardial infarction, for example.

Host/User Interface

The various details of the system 10 described above with reference to Figs. 1 and 2 will be described with reference to the remaining Figs. Turning now to Fig. 3, an exemplary embodiment of the host/user interface 66 is illustrated. The host/user interface 66 includes a user interface 84 and a host interface 85. The user interface 84 may include a user input and display device, such as a touch screen display 86. As illustrated in Fig. 4, the touch screen display 86 may include "buttons" 87 that initiate certain operations when a user touches them. The touch screen display 86 may also include information such as alarms/messages 88, status indicators 89, blood flow information 90, and bubble count 91.

The user inputs are handled by a touch screen driver 92, and the displayed information is handled by a display driver 93. The touch screen driver 92 transmits user inputs to an interface, such as an RS-232 interface 94. The RS-232 interface 94 may communicate these user inputs to other portions of the system 10, such as the system controller 55, the interlock system 44, the blood pump system 24, and the bubble detector 74. The display driver 93 communicates with a display controller 95, which is also coupled to the RS-232 interface 94 via a bus 96. The display controller 95 receives updated information from the various other portions of the system 10, and it uses this information to update the display 86.

10

The host interface 85 may also include various other capabilities. For example, the host interface 85 may include a sound card 97 to drive speakers 98 on the user interface 84. In addition, a network adapter 99 may allow the host interface 85 to communicate with an external network, such as a LAN in the hospital or a remote network for providing updates for the system 10, e.g., the Internet. Finally, the host interface 85 may include an analog and/or digital I/O device 101, which in this example transmits and receives certain signals such as an enable signal, a "request to stop" signal, a draw pressure signal, and a return pressure signal.

20

Blood Pump System and Interlock System

Many of the components described below, while particularly useful in the exemplary system 10, may be quite useful in other types of systems as well. For example, the blood pump system 24 described in detail with reference to Fig. 5 may be used not only in the context of the system 10, but also in other types of perfusion systems, such as conventional heart-lung machines and other types of other extracorporeal circuits. As previously discussed, the blood pump system 24 utilizes a suitable pump 40, such as a peristaltic pump, to draw blood from the patient 38 through a draw tube 34. The blood pump system 24 further includes a flow meter 46, such as a transonic flow meter, which communicates with a flow transducer 48 via lines 100 and 102. The feedback from the transducer 48 enables the blood pump system 24 to maintain the desired flow rate. The desired flow rate may be entered by a user, such as perfusionist or a nurse, via the control panel 30. In this example, the control panel 30 includes an indication of the current blood flow rate in milliliters per

30

minute, as well as an “up” button 104 and a “down” button 106 that permit a user to adjust the blood flow rate upwardly and downwardly, respectively. The control panel 30 further includes a “prime” button 108, a “start” button 110, and a “stop” button 112. In addition, the control panel 30 may be augmented by a foot switch 114, which includes a stop pedal 116, which performs the same function as the stop button 112, and a prime start pedal 118, which performs the same function as the prime button 108 and the start button 110.

Because the blood pump system 24 utilizes feedback from the flow transducer 48 to maintain and adjust the r.p.m. of the pump 40 in a manner which provides a consistent flow rate, the blood pump system 24 requires no user interaction once the system has been primed and the flow rate has been set. Therefore, unlike blood pumps used in other extracorporeal circuits, the blood pump system 24 may be operated by a semi-skilled technician or nurse, rather than a highly skilled perfusionist.

To provide an extra measure of confidence with such semi-skilled operation, the blood pump system 24 takes advantage of certain features provided by the interlock system 44. For example, referring to the interlock system 44 illustrated in Fig. 6 as well, the interlock system 44 may include or have access to a personality module 120. The personality module 120 may include a memory 122, such as a read only memory for example. The memory 122 of the personality module 120 may include various information, such as flow rates and ranges, as well as other information to be discussed below. Therefore, for a particular patient or for a particular type of patient, the desired flow rate and/or the desired flow rate range may be programmed into the memory 122. For example, in acute myocardial infarction applications, the flow rate may be 75 milliliters per minute, or for stroke applications the flow rate may be 300 milliliters per minute. In this exemplary embodiment, the personality module 120 may be located in the Y-connector 71. Because the information programmed into the personality module 120 may be related to a particular patient or a particular type of patient, and because a new Y-connector 71 is typically used with each patient, the location of the personality module 120 in the Y-connector 71 provides an effective method of customizing the system 10 with each patient treated.

The interlock system 44 reads this flow information from the memory 122 and compares it to the flow rate delivered by the flow meter 46 on line 124. As long as the flow rate from the flow meter 46 is maintained at the desired flow rate or within the desired flow range programmed into the memory 122, the interlock system 44 will continue to supply an enable signal on line 126 to the blood pump system 24. However, should the flow rate fall outside of the desired range, due to operator intervention, failure of the flow transducer 48, etc., the interlock system 44 will switch the signal on the line 126 to disable the blood pump system 24. The interlock system 44 will further actuate the clamps 78 and 80 in order to shut down the system 10 in a manner safe for the patient 38.

10

The interlock system 44 includes an analog conditioning circuit 130 that receives and conditions the analog flow rate signal from the flow meter 46 on the line 124. This conditioned signal is compared with the information from the memory 122 using comparators and threshold settings 132. The results of this comparison are delivered to a logic block 134, which may be, for example, a field programmable gate array (FPGA) or a complex programmable logic device (CPLD). The logic block 134 generates the enable or disable signal on the line 126.

The conditioning circuit 130 also receives the analog pressure signals from the draw pressure transducer 68 and the return pressure transducer 70. These pressures may be monitored to ensure that neither the draw tube 34 nor the return tube 50 are kinked or otherwise unable to deliver fluid at a minimum desired pressure or higher. The logic block 134 compares these pressures to the minimum pressure setting, e.g., -300 mm Hg, and delivers a warning signal if either pressure drops below the minimum pressure setting. In addition, the draw pressure is monitored to ensure that it remains higher than a minimal draw pressure threshold, e.g., -300 mm Hg, to ensure that bubbles are not pulled out of solution by the blood pump 40. Still further, the return pressure is monitored to ensure that it does not exceed a maximum return pressure, e.g. 2000 mm Hg.

The manner in which the interlock system 44 interfaces with various other portions of the system 10 will be discussed below where appropriate. However, it can be seen that the blood pump system 24 and the interlock system 44 provide a technique by which blood may

be removed from a patient at a desired and maintainable flow rate and that any deviation from the desired flow rate will cause the system to shut down in a manner which is safe for the patient 38. Accordingly, the use of a perfusionist may be obviated in most circumstances.

5

Oxygenation Device

Although the blood pump system 24 may be used in a variety of different systems, for the primary purpose of this discussion it is incorporated within the system 10. As described in reference to Fig. 2 above, one of its main purposes is to deliver blood to the oxygenation device 54. Accordingly, before discussing the blood pump system 24 or the other components further, an understanding of the manner in which the oxygenation device 54 functions is appropriate.

Referring first to Figs. 7, 8, and 9, an exemplary embodiment of an oxygenation device 54 is illustrated. As mentioned previously, the oxygenation device 54 includes three chambers: a fluid supply chamber 58, an atomization chamber 62, and a mixing chamber 64. Generally speaking, physiologic fluid, such as saline, is drawn into the fluid supply chamber 58. The physiologic fluid is transferred under pressure from the fluid supply chamber 58 to the atomization chamber 62. In the atomization chamber 62, the physiologic fluid is enriched with a gas, such as oxygen, to form a gas-enriched physiologic fluid. For example, the physiologic fluid may be supersaturated with the gas. The gas-enriched physiologic fluid is transferred to the mixing chamber 64 to be combined with a bodily fluid, such as blood. The mixing of the gas-enriched physiologic fluid with the bodily fluid forms a gas-enriched bodily fluid. In one example, blood from a patient is mixed with an oxygen-supersaturated saline solution and transmitted back to the patient.

Beginning with a detailed discussion of the fluid supply chamber 58, an appropriate delivery device, such as a tube 140, is coupled to a supply of physiologic fluid. In this example, the tube 140 may include a drip chamber 141 and is coupled at one end to an IV bag 56. The other end of the tube 140 is coupled to a nozzle 142. The nozzle 142 forms a portion of a fluid passageway 144 that leads to the fluid supply chamber 58. A check valve

146 is disposed in the fluid passageway 144 so that fluid may enter the fluid chamber 58 through the fluid passageway 144, but fluid cannot exit through the fluid passageway 144.

As illustrated by the detailed view of Fig. 10, check valve 146 has an O-ring seal 148 that is disposed between a lip in the fluid passageway 144 and the nozzle 142. A spring 150 biases a ball 152 into contact with the O-ring seal 148. When fluid moving in the direction of the arrow 154 overcomes the force of the spring 150 and the pressure within the fluid supply chamber 58, the ball 152 is pushed against the spring 150 so that fluid may flow into the fluid supply chamber 58. However, fluid cannot flow in the opposite direction because the ball 152 efficiently seals against the O-ring seal 148.

A piston assembly 160 is disposed at the opposite end of the fluid supply chamber 58. The piston assembly 160 includes a sleeve 162 that is fixedly disposed within the fluid supply chamber 58. As illustrated in greater detail in Fig. 11, a plunger 164 is slidably disposed within the sleeve 162. A cap 166 is disposed at one end of the plunger 164. The cap includes a flange 168 that has an outer diameter greater than the inner diameter of the sleeve 162 to limit downward movement of the piston assembly 160. Although the sleeve 162, the plunger 164, and the cap 166 are advantageously made of a relatively rigid material, such as plastic, a relatively resilient end piece 170 is disposed on the cap 166. The end piece 170 advantageously includes sealing members 172 that seal against the interior walls of the fluid supply chamber 58.

As illustrated by the phantom lines in Fig.11, the piston assembly 160 is moveable between a first position (shown by the solid lines) and a second position (shown by the phantom lines). To facilitate this movement, a device to be described below is coupled to the free end 174 of the piston assembly 160. Although such coupling may occur in various suitable manners, in this example a key 176 is provided at the free end 174 of the piston assembly 160. The key 176 includes a narrow portion 178 and a relatively wider portion 180 so that it somewhat resembles a doorknob, thus allowing a device to latch onto the piston assembly 160 and move it between the first and second positions.

As will be appreciated from a thorough study of this entire discussion, one of the primary advantages of the particular oxygenation device 54 disclosed herein involves its sterility and disposability. The sterility of the piston assembly 160 may be facilitated by providing a sterility sheath 182 disposed between the cap 166 and the sleeve 162. In this
5 embodiment, the sterility sheath 182 includes an extendable tube 184 that is coupled to the cap 166 by a clamp 186 and coupled to the outer portion of the sleeve 162 by a clamp 188. The expandable tube 184 may take various forms, such as a plastic tube that folds in an accordion-like manner when the piston assembly 160 is in its retracted position (as shown by the solid lines). However, the expandable tube 184 may take various other forms, such as a
10 flexible member that stretches between the retracted position and the extended position of the piston assembly 160. The clamps 186 and 188 may also take various suitable forms, such as rubber O-rings in this example.

Referring additionally to Fig. 12, the fluid supply chamber 58 further includes a
15 second fluid passageway 190. As illustrated by way of a specific example in the present embodiment, the fluid passageway 190 is coupled to a fluid passageway 194 by a tube 196. The passageway 194 is an inlet to a valve assembly 200 that controls the manner in which fluid from the fluid supply chamber 58 is delivered into the atomization chamber 62.

20 In operation, the piston assembly 160 within the fluid supply chamber 58 acts as a piston pump. As the piston assembly 160 retracts, fluid is drawn into the chamber 58 from the fluid supply 56. No fluid can be drawn from passageway 190 because valve assembly 200 is closed and a check valve 192 is closed in this direction. As the piston assembly 160 extends, the fluid within the chamber 58 is pressurized, typically to about 670 psi, and
25 expelled from the fluid supply chamber 58 through the fluid passageway 190. The outlet of the fluid supply chamber 58 is coupled to an inlet of the atomization chamber 62 via an appropriate fluid passageway.

Detailed views of the valve assembly 200 are illustrated in Figs. 13 and 14. The valve
30 assembly 200 includes three valves: a fill valve 202, a flush valve 204, and a flow valve 206. While any suitable valve arrangement and type of valve may be used, in this embodiment the valves 202, 204, and 206 are needle valves that are normally biased in the closed position as

shown. When the pressure within the atomization chamber 62 rises above a certain level, such as about 100 psi, the valves 202, 204, and 206 will move from the closed position to the opened position, assuming that they are allowed to do so. In this embodiment, as will be discussed in greater detail below, push pins and associated actuation mechanisms (as
5 illustrated by the phantom lines in Fig. 13) maintain the valves 202, 204, and 206 in the closed positions until one or more of the valves 202, 204, and 206 is to be opened.

Gas, such as oxygen, is delivered under pressure to the atomization chamber 62 via a passageway 210. For example, the oxygen tank 60 may be coupled to the inlet of the
10 passageway 210 to provide the desired oxygen supply. If all of the valves 202, 204, and 206 are closed, fluid flows from the inlet passageway 194 into a passageway 212 in which the fill valve 202 is located. Because the cross-sectional area of the passageway 212 is larger than the cross-sectional area of the fill valve 202, the fluid flows around the closed fill valve 202 and into a passageway 214 that leads to an atomizer 216.

15

The atomizer 216 includes a central passageway 218 in which a one-way valve 220 is disposed. In this embodiment, the one-way valve 220 is a check valve similar to that described with reference to Fig. 10. Accordingly, when the fluid pressure overcomes the force of the spring in the one-way valve 220 and overcomes the pressure of the gas within the
20 atomizer chamber 62, the fluid travels through the passageway 218 and is expelled from a nozzle 222 at the end of the atomizer 216.

The nozzle 222 forms fluid droplets into which the oxygen within the atomization chamber 62 diffuses as the droplets travel within the atomization chamber 62. This oxygen-enriched fluid may be referred to herein as aqueous oxygen (AO). In this embodiment, the
25 nozzle 222 forms a droplet cone defined by the angle α , which is typically about 20 degrees to about 40 degrees at normal operating pressures, e.g., about 600 psi, within the atomization chamber 62. The nozzle 222 is a simplex-type, swirled pressurized atomizer nozzle including a fluid orifice of about 0.004 inches diameter to 0.005 inches diameter. It
30 should be appreciated that the droplets infused with the oxygen fall into a pool at the bottom of the atomizer chamber 62. Since the atomizer 216 will not atomize properly if the level of

the pool rises above the level of the nozzle 222, the level of the pool is controlled to ensure that the atomizer 216 continues to function properly.

5 The oxygen is dissolved within the atomized fluid to a much greater extent than fluid delivered to the atomizer chamber 62 in a non-atomized form. As previously stated, the atomizing chamber typically operates at a constant pressure of about 600 psi. Operating the atomizer chamber 62 at 600 psi, or any pressure above 200 psi, advantageously promotes finer droplet formation of the physiologic solution from the atomizer 216 and better saturation efficiency of the gas in the physiologic fluid than operation at a pressure below
10 200 psi. As will be explained shortly, the oxygen-supersaturated fluid formed within the atomizer chamber 62 is delivered to the mixing chamber 64 where it is combined with the blood from the patient 38. Because it is desirable to control the extent to which the patient's blood is enriched with oxygen, and to operate the system 10 at a constant blood flow rate, it may be desirable to dilute the oxygen-supersaturated fluid within the atomizer chamber 62
15 to reduce its oxygen content. When such dilution is desired, the fill valve 202 is opened to provide a relatively low resistance path for the fluid as compared to the path through the atomizer 216. Accordingly, instead of passing through the atomizer 216, the fluid flows through a passageway 230 which extends upwardly into the atomizer chamber 62 via a tube 232. The tube 232 is advantageously angled somewhat tangentially with respect to the
20 cylindrical wall of the atomizer chamber 62 so that the fluid readily mixes with the oxygen-supersaturated fluid in the pool at the bottom of the atomizer chamber 62.

The valve assembly 200 essentially performs two additional functions. First, with the fill valve 202 and the flow valve 206 closed, the flush valve 204 may be opened so that fluid
25 flows from the inlet passageway 194, through the passageways 212 and 214, and into passageways 240 and 242, the latter of which has a cross-sectional area larger than the cross-sectional area of the flow valve 206. Thus, the fluid flows out of an outlet passageway 244 that is coupled to a capillary tube 246. The capillary tube 246 terminates in a tip 248 that extends upwardly into the mixing chamber 64. Since this fluid has not been gas-enriched, it
30 essentially serves to flush the passageways 242 and 244, and the capillary tube 246 to remove any contaminants and to ensure adequate fluid flow. Second, with the fill valve 202 and the flush valve 204 closed, the flow valve 206 may be opened when it is desired to deliver the

gas-supersaturated fluid from the pool at the bottom of the atomizer chamber 62 into the mixing chamber 64.

5 In this second circumstance, the gas-supersaturated fluid readily flows from the atomization chamber 62 through the capillary tube 246 and into the mixing chamber 64 due to the fact that pressure within the atomization chamber 62 is relatively high, e.g., approximately 600 psi, and pressure within the mixing chamber 64 is relatively low, e.g., about 30 psi. The end of the capillary tip 248 is advantageously positioned below a blood inlet 250 of the mixing chamber 64. This spacial arrangement typically ensures that the
10 blood flowing through the draw tube 34 and into the blood inlet 250 effectively mixes with the oxygen-supersaturated fluid flowing into the mixing chamber 64 through the capillary tip 248. Finally, by the force of the blood pump system 24, the oxygenated blood is pumped out of the mixing chamber 64 through an outlet 252 into the return tube 50.

15 Typically, the capillary tube 246 and the capillary tip 248 are relatively long to ensure that proper resistance is maintained so that the oxygen within the oxygen-supersaturated fluid remains in solution as it travels from the atomization chamber 62 into the mixing chamber 64. For example, the capillary tube 246 and the tip 248 may be in the range of 50 microns to 300 microns in length and in the range of 3 inches to 20 inches in
20 internal diameter. To maintain the compact size of the oxygenation device 54, therefore, the capillary tube 246 is wrapped about the exit nozzle 252 of the mixing chamber 64, as illustrated in the detailed drawing of Fig. 15. To protect the coiled capillary tube 246 from damage, a protective shield 254 is advantageously formed around the coiled capillary tube 246 to create a compartment 256.

25 Both the atomization chamber 62 and the mixing chamber 64 include vent valves 258 and 260, respectively. The vent valves 258 and 260, as illustrated in the detail drawing of Fig. 16, are one-way valves that allow gas pressure to be vented out of the oxygenation device 54 and into the atmosphere. In this particular embodiment, the vent valves 258 and
30 260 include a plunger 262 that is biased in a closed position against an O-ring seal 264 by a spring 266. The biasing force is light so that only one to two psi within the respective chambers 62 or 64 is sufficient to move the plunger 262 away from the seal 264 to vent the

chamber. Therefore, as will be discussed in greater detail below, actuation devices that are part of the cartridge enclosure 26 and controlled by the system controller 55 normally maintain the valves 258 and 260 in the closed position.

5 Before beginning a discussion of the remainder of the system 10, a few points regarding oxygenation of blood in general, and the use of the disclosed oxygenation device 54 in particular, should be noted. First, various methods of oxygenating blood are known or under development. Although an atomizing chamber provides a convenient mechanism for diffusing relatively large amounts of gas into a fluid in a relatively short period of time, it is
10 not the only way of dissolving gas within a fluid. Indeed, other devices, such as membrane oxygenators, gas spargers, bubblers, and thin film oxygenation devices, may be used to perform this function as well. Second, although a piston pump similarly provides a compact and efficient method of pressurizing fluid prior to sending it to an oxygenator, such as the atomizer, other types of pumps or methods of pressurization may be used as well. Third,
15 although a mixing chamber provides a compact environment in which the mixing of the gas-supersaturated fluid with blood may be appropriately monitored and controlled, gas-enriched fluid may be mixed with blood in other ways. For example, gas-supersaturated fluid may be mixed with blood within the mixing zone of a catheter or other suitable device. Therefore, although a piston pump, atomizer, and mixing chamber comprise the
20 oxygenation device 54 utilized in the exemplary embodiment of the system 10, due to certain perceived advantages, other devices can, generally speaking, perform these functions.

 With these generalities in mind, the oxygenation device 54 disclosed herein offers several advantages that make it particularly attractive for use within a medical environment.
25 First, the oxygenation device 54 is advantageously made from a clear plastic, such as polycarbonate which can be molded to provide a high strength, low cost device. Second, the oxygenation device 54 is relatively compact, with an exemplary specimen measuring approximately 12 cm in height, 10 cm in width, and 5.5 cm in depth. Thus, it can be utilized within a system 10 that fits easily within an operating room or special procedures
30 lab, regardless of whether the system 10 is fixed or mobile. Third, the oxygenation device 54 combines the preparation of the oxygen-enriched fluid, along with the mixing of the oxygen-enriched fluid with the blood, into a unitary device utilizing only four connections: (1) fluid

supply, (2) oxygen supply, (3) blood supply, and (4) blood return. The other connections are part of the oxygenation device 54 itself, and they require no additional connection from the user. Fourth, all of the valves used to operate the oxygenation device 54 are integrated within its unitary structure. Thus, the valves and their associated fluid passageways are protected against external contamination, and users are protected against any contamination that may arise from the use of the various fluids as well. As a result, the oxygenation device 54 is a relatively contamination-free cartridge that may be used during a surgical procedure on a patient, and then removed and replaced prior to performing a surgical procedure on the next patient.

Cartridge Enclosure

Prior to discussing the remainder of the electrical components and the manner in which they control the various mechanical components of the system 10, the manner in which certain mechanical components interface with the oxygenation device 54 will now be discussed. As mentioned previously, the oxygenation device 54 is placed inside of the cartridge enclosure 26. Fig. 17 illustrates an exploded view of the cartridge enclosure 26, and Fig. 18 illustrates a front view of the cartridge enclosure 26. In this embodiment, the cartridge enclosure 26 includes a cartridge receptacle 302 that is accessed by a hinged door 304. When the oxygenation device 54 is placed within the cartridge receptacle 302, the door 304 is closed and latched for various reasons. First, the cartridge receptacle 302 and the oxygenation device 54 are sized and shaped in a complementary fashion so that the various surfaces, vents, valves, etc. are positioned in a desired manner. When the door 304 is closed and latched, an inner surface 306 of the door 304 advantageously presses against a surface 308 of the oxygenation device 54 to ensure that the positioning of the oxygenation device 54 is accurate. Second, the door 304 is advantageously locked to prevent removal of the oxygenation device 54 during normal operation of the system 10. Accordingly, the door 304 is provided with a latch 310. Referring to Figs. 19-26, the door latch 310 includes a handle portion 312 and a latching portion 314.

To latch the door 304, a user grasps the handle portion 312 to pivot the latch 310 about a pivot pin 316 generally in the direction of the arrow 318. As the latch 310 pivots in the direction of the arrow 318, the latching portion 314 hooks around a latch pin 320. The

latch pin 320 is coupled to a biasing mechanism 322. The biasing mechanism 322, in this embodiment, includes two pins 324 and 326 that extend through holes in a wall 328. A respective spring 330 and 332 is disposed about each pin 324 and 326 to bias the latch pin 320 toward the wall 328. As the latching portion 314 hooks around the latch pin 320, the
5 latch 310 may tend to overcome the bias of the springs 330 and 332 to move the latching mechanism 322 slightly in the direction of the arrow 334. However, due to the bias of the latching mechanism 322, it tends to hold the latch 310, and thus the door 304, tightly in place.

10 To keep the latch 310 in place, and thus lock the door 304, a locking mechanism 340 is provided. In this embodiment, the locking mechanism includes 340 a slidable pin 342 that is disposed in a portion of the wall 328. As the latch 310 moves in the direction of the arrow 318, it eventually contacts the front end of the pin 342, and thus moves it in the direction of the arrow 344. The rear portion of the pin 342 is coupled to a piston 346 of a
15 pull-type solenoid 348. The piston 346 is biased outwardly by a spring 350, so that the piston 346 is normally in an extended position.

The latch 310 is configured so that as it reaches its latched position, the spring 350 pushes the pin 342 in the direction of the arrow 352 so that the pin 342 extends over a
20 portion 354 of the latch 310. With the pin 342 in its locked position over the portion 354 of the latch 310, the latching portion 314 cannot be removed from the latching mechanism 322. Instead, the latch 310 remains locked until the piston 346 of the solenoid 348 is retracted to move the pin 342 out of the way of the latch 310.

25 It should also be noted that the latch 310 includes a sensor 360 that provides an electrical signal indicative of whether the latch 310 is in its locked position. In this embodiment, the sensor 360 is a Hall effect sensor. The latch 310 includes a magnet 362 that is positioned to align with the sensor 360 when the latch 310 is in the locked position. When the magnet 362 is aligned with the sensor 360, the electromagnetic signal is
30 uninterrupted. However, until the magnet 362 reaches alignment, the electromagnetic signal from the sensor 360 is interrupted, thus indicating that the latch 310 is not yet in its locked position.

Valve Actuation

As mentioned previously, in the present embodiment, the size and shape of the oxygenation device 54, the contour of the cartridge receptacle 302, and the closing of the door 304 ensure that the oxygenation device 54 is positioned in a desired manner within the cartridge enclosure 26. Correct positioning is of concern due to the placement of the valves and vents of the oxygenation device 54 and the manner in which they are controlled and actuated. As mentioned earlier, the valves and vents of the oxygenation device 54 are actuated using pins in this embodiment. The top of the oxygenation device 54 includes vents 258 and 260, and the bottom of the oxygenation device 54 includes three valves, 202, 204, and 206. In this embodiment, these vents 258 and 260 and valves 202, 204 and 206 are electromechanically actuated using solenoid-actuated pins.

A detailed view of these actuation devices is illustrated in Figs. 27-32. Referring first to Fig. 27, a bottom view of the cartridge enclosure 26 is illustrated. The oxygenation device 54 is illustrated by phantom lines. It should be noted that the bottom portion of the cartridge enclosure 26 advantageously includes a slot 380 through which the blood return tube 50 of the oxygenation device 54 may pass. Once the oxygenation device 54 is in place within the cartridge enclosure 26, the fill valve 202, the flush valve 204, and the flow valve 206 should be in alignment with respective actuation pins 382, 384, and 386. Advantageously, each of the pins 382, 384, and 386 is tapered at the end to provide an increased tolerance for misalignment. Each of the actuation pins 382, 384, and 386 is moved between a closed position and an open position by a respective solenoid 388, 390, and 392. Each of the solenoids 388, 390, and 392 is coupled to its respective actuation pin 382, 384, and 386 via a respective lever 394, 396, and 398. Each of the respective levers 394, 396, and 398 pivots on a respective fulcrum or pivot pin 400, 402, and 404.

The manner in which the actuators operate may be understood with reference to Figs. 28 and 29. While these figures only illustrate the actuator for the flush valve 204, it should be understood that the other actuators operate the fill valve 202 and the flow valve 206 in the same manner. As mentioned previously, the valves 202, 204, and 206 are normally held in a closed position. Accordingly, in this particular embodiment, the

solenoids 388, 390, and 392 are pull-type solenoids. As illustrated in Fig. 28, a piston 406 of the pull-type solenoid 390 is urged into an extended position by a spring 408 that biases one end of the lever 396 generally in the direction of the arrow 410. As a result, the spring 408 also biases the actuation pin 384 generally in the direction of the arrow 412 to maintain
5 the flush valve 204 in its closed position.

To allow the flush valve 204 to open, the solenoid 390 is actuated as illustrated in Fig. 29. The actuation of the pull-type solenoid 390 moves the piston 406 generally in the direction of the arrow 414 into a retracted position. The force of the solenoid 390
10 overcomes the bias of the spring 408 and moves the actuation pin 384 generally in the direction of the arrow 416. With the actuation pin 384 in a retracted position, the flush valve 204 may open by moving in the direction of the arrow 416.

The actuation of the vent valves 258 and 260 takes place in a similar fashion.
15 Referring now to Fig. 30, a top view of the cartridge enclosure 26 is illustrated. The top portion of the cartridge enclosure 26 also includes a slot 420 through which the IV tube 140 may pass. Once the oxygenation device 54 is properly positioned within the cartridge enclosure 26, the vent valves 258 and 260 align with actuation pins 422 and 424, respectively. The pins 422 and 424 are also advantageously tapered at the ends to increase
20 tolerance to misalignment. Each of the actuation pins 422 and 424 is actuated by a respective solenoid 426 and 428. Each of the solenoids 426 and 428 is coupled to the respective actuation pin 422 and 424 by a respective lever 430 and 432. Each of the levers 430 and 432 pivots about a fulcrum or pivot pin 434 and 436, respectively.

25 As described with reference to Figs. 31 and 32, the operation of the actuators for the valves 258 and 260 is similar to the operation of the actuators for the valves 202, 204, and 206. Although Figs. 31 and 32 illustrate only the actuator for the vent valve 260, it should be understood that the actuator for the vent valve 258 operates in a similar manner. Referring first to Fig. 31, the solenoid 428 in this embodiment is a pull-type solenoid. A
30 spring 440 generally biases the lever arm 432 in the direction of the arrow 442 to move a piston 444 of the solenoid 428 into an extended position. Accordingly, by virtue of the action of the lever 432 about the pivot pin 436, the spring 440 moves the actuation pin 424

into an extended position. In the extended position, the actuation pin 424 exerts pressure on the vent valve 260 (not shown) to maintain the vent valve 260 in a closed position.

To open the vent valves 258 and 260, the solenoids 426 and 428 are actuated. As
5 illustrated in Fig. 32, when the pull-type solenoid 428 is actuated, the piston 444 moves into a retracted position generally in the direction of the arrow 446. The force of the solenoid 428 overcomes the biasing force of the spring 440 and, thus, the lever 432 moves the actuation pin 424 generally in the direction of the arrow 448 into a retracted position. When the actuation pin 424 is in the retracted position, the vent valve 260 may move
10 upwardly to open and vent gas within the mixing chamber 64.

Cartridge Sensors

Referring again to Fig. 18, a study of the cartridge receptacle 302 reveals that a number of sensors are utilized to monitor and/or control the system 10 in general and the
15 oxygenation device 54 in particular. Due to the nature of the information to be gathered and the types of sensors used to gather this information, the oxygenation device 54 and the sensors include certain features that facilitate the gathering of such information in a more accurate and robust manner. However, it should be appreciated that other types of sensors and/or features may be utilized to gather similarly relevant information for use in monitoring
20 and/or controlling the system 10 and oxygenation device 54.

As will be appreciated from a detailed discussion of the electronic controls of the system 10, it is desirable to monitor and control fluid levels within the atomization chamber 62 and the mixing chamber 64. Accordingly, an AO level sensor 480 is provided to monitor
25 the level of aqueous oxygen within the atomizer chamber 62, and a high level sensor 482 and a low level sensor 484 are provided to monitor the level of the oxygen-enriched blood within the mixing chamber 64. As mentioned above, because the oxygenation device 54 is configured as a replaceable cartridge in this exemplary embodiment, the sensors have been placed within the cartridge enclosure 26 instead of within the oxygenation device 54. Thus,
30 the level sensors 480, 482, and 484 do not actually contact the fluid within the chambers 62 and 64. Were the sensors 480, 482, and 484 to contact the liquid, they could become contaminated and, thus, the sensors would typically be replaced each time the system 10 was

used for a different patient. Since this would likely add to the cost of replacement items, and potentially affect the sterility of the system, from both a user's standpoint and a patient's standpoint, it is desirable that the sensors do not contact the liquid within the oxygenation device 54.

5

In this embodiment, the sensors 480, 482, and 484 are ultrasonic sensors. Because ultrasonic waves travel more efficiently through solids and liquids than through air, it is desirable that the sensors 480, 482, and 484 and/or the oxygenation device 54 be configured in a manner which promotes the efficient transmission and reception of ultrasonic waves. In
10 this embodiment, both the sensors 480, 482, and 484 and the oxygenation device 54 include features which prove advantageous in this regard.

Figs. 19 and 33 are cross-sectional views of the cartridge enclosure 26 that illustrate the high level sensor 482 and the AO level sensor 480, respectively. Although the low level
15 sensor 484 is not illustrated in cross-section, it should be understood that its construction is similar to or identical to the construction of the sensors 480 and 482. Furthermore, detailed views of the sensors 482 and 480 are illustrated in Figs. 34 and 35, respectively, again with the understanding that the sensors 480, 482, and 484 are substantially identical in regard to the details shown in these Figs.

20

To ensure that physical contact is maintained between the oxygenation device 54 and the sensors 480, 482, and 484, the sensors are advantageously biased into contact with the oxygenation device 54. The sensors 480, 482, and 484 actually utilize a spring-biasing technique, although various other types of biasing techniques may be utilized to achieve
25 similar results. In this example, an ultrasonic transducer element 490 is disposed within a channel 492 formed within a sensor body 494. The sensor body 494 may be formed in any suitable shape, but it is illustrated in this embodiment as being cylindrical. The sensor body 494 is slidably disposed within a sleeve 496. The sleeve 496 is fixedly disposed in a wall 498 of the cartridge enclosure 26. For example, the sleeve 496 may have external screw threads
30 500 so that the sleeve 496 may be screwed into a threaded bore in the wall 498. To facilitate slidable movement of the sensor body 494 within the sleeve 496, a bushing 502 may be provided within the sleeve 496. In this example, the sensor body 494 includes an annular

flange 504 that abuts against one end of the bushing 502 in order to limit outward movement of the sensor body 494. A spring 506 is disposed in the rear portion of the sleeve 496. The spring 506 abuts against the opposite side of the annular flange 504 to bias the sensor body 494 generally in the direction of the arrow 508. The bushing 502 may be
5 adhered to, or an integral part of, the sleeve 496, or it may be held in place by an external seal or cap 510.

Although the spring-loaded construction of the sensors 480, 482, and 484 tends to bias the sensors into contact with the oxygenation device 54 to facilitate the efficient
10 transmission of ultrasonic energy, the nature of the contact between the end of the sensor and the oxygenation device 54 is also important for efficient ultrasonic wave transmission. Hence, to improve this contact region, the sensors 480, 482, and 484 include a resilient member 512, such as a rubber cap. The resilient member 512 is able to deform slightly as it
15 contacts the oxygenation device 54 to ensure that a good contact is made. To enhance the contact region further, the oxygenation device 54 advantageously includes flat contact portions 514 and 516, respectively, so that the contour of the oxygenation device 54 matches the contour of the resilient member 512. In addition, to enhance the ultrasonic contact even
further, a suitable gel may be used between the oxygenation device 54 and the sensors 480,
482, and 484.

20

The cartridge enclosure 26 advantageously includes other sensors as well. For example, it may be desirable for the system 10 to be able to determine whether the oxygenation device 54 has been inserted within the cartridge enclosure 26. To provide this
25 information, a cartridge present sensor 520 may be disposed within the cartridge enclosure 26. In this example, the cartridge present sensor 520, as illustrated in Fig. 19, may be a reflective infrared sensor that is positioned within an opening 522 in the wall 498 of the cartridge enclosure 26. Unlike the ultrasonic sensors discussed previously, the efficiency of a reflective infrared sensor is not improved by physical contact. Indeed, the efficiency of a reflective infrared sensor relates more to the nature of the surface reflecting the infrared
30 energy back to the sensor. In other words, if the surface is irregular, the infrared energy transmitted from the infrared sensor may scatter so that little or no infrared energy is reflected back to the sensor. On the other hand, if the surface is smooth, generally

perpendicular to the sensor, and/or reflective, it tends to maximize the amount of infrared energy reflected back to the sensor. Accordingly, the portion of the oxygenation device 54 positioned adjacent the cartridge present sensor 520 is advantageously configured to promote reflection of infrared energy back to the cartridge present sensor 520. In this example, the oxygenation device 54 advantageously includes a flat section 524 to ensure that the cartridge present sensor 520 receives a relatively strong reflective signal so that it can properly indicate whether the oxygenation device 54 is present.

It may also be desirable to monitor the temperature of the aqueous oxygen formed within the atomizer chamber 62. The temperature of the aqueous oxygen is a useful parameter because the oxygenation level of the aqueous oxygen, and ultimately the oxygenation level of the oxygen-enriched blood, may vary with temperature. If it is desirable to take a temperature measurement into account to monitor and control the functioning of the oxygenation device 54 and the system 10, the temperature may be sensed in a variety of different areas. For example, a simple room temperature sensor may be incorporated somewhere within the system 10, using the assumption that the physiologic solution to be oxygenated will typically be at room temperature. Alternatively, the temperature of the oxygenation device 54 may be monitored, using the assumption that the aqueous oxygen within the oxygenation device 54 will be at the same temperature.

However, to provide the greatest level of control, it may be desirable to measure the temperature of the aqueous oxygen within the atomizer chamber 62. Although a thermocouple could be disposed in the atomizer chamber 62 of the oxygenation device 54 with appropriate electrical contacts extending out of the oxygenation device 54, the use of a sensor within a disposable device would only increase the cost of the device. Accordingly, it may be desirable to utilize a sensor that is external to the atomizer chamber 62 and yet still able to monitor the temperature of the aqueous oxygen within the atomizer chamber 62. To achieve this function in this example, an external temperature sensor 540 is coupled within an opening 542 in the wall 498 of the cartridge enclosure 26 as illustrated in Fig. 33. The temperature sensor 540 may be, for example, a pyroelectric sensor or a piezoelectric sensor. Changes in the temperature of the AO solution within the atomizer chamber 62 will alter the frequencies of such signals and, thus, indicate the actual temperature of the AO solution.

Gas Coupling

The cartridge enclosure 26 also includes another interesting feature regarding the manner in which it interfaces with the oxygenation device 54. As previously discussed, the oxygenation device 54 includes an oxygen inlet 210 located near the top of the atomizer chamber 62. As also previously mentioned, a supply of oxygen 60 regulated to about 600 psi is coupled to the oxygen inlet 210. Thus, it may be desirable to provide a connection to the inlet 210 that effectively handles such pressure and does not require user intervention.

Referring to Fig. 36, the oxygen supply 60 is typically enabled by a flow valve 600. The flow valve 600 delivers oxygen through a pressure transducer 602 and a check valve 604. The oxygen then proceeds through a tee 606 and into a line 608. The line 608 is coupled to a plunger 610 illustrated in the cross-sectional view of Fig. 37. The plunger 610 includes a port 612 that runs laterally from the line 608 and then downwardly into the cartridge cavity 302. The plunger 610 is slidably disposed within a bushing or sleeve 614. As best illustrated in the detailed views of Figs. 38 and 39, the sleeve 614 includes a recessed area 616 in which a spring 618 is disposed. The spring tends to bias the plunger 610 upwardly so that the coupling portion 620 of the plunger 610 that is configured to seal against the oxygen inlet 210 of the oxygenation device 54 is recessed slightly.

The top of the plunger 610 includes a slanted or cammed portion 622 that abuts in a complimentary relationship with a slanted or cammed portion 624 of a rod 626. The rod 626 is slidably disposed within an opening 628 in the cartridge enclosure 26. The rod 626 is biased in the direction of the arrow 630 in an extended position by a spring 632. As best illustrated in Fig. 39, when a user closes the door 304, the rod 626 is moved in the direction of the arrow 634 against the bias of the spring 632. As the rod 626 moves back against the spring 632, the cammed surfaces 622 and 624 slide against one another, thus forcing the plunger 610 downwardly in the direction of the arrow 636 to seal the coupling portion 620 against the oxygen inlet 210. The rod 624 is advantageously provided with an adjustment screw 638. The adjustment screw 638 may be adjusted so that the abutment portion 640 of the rod 626 is in an appropriate position to ensure that the coupling portion 620 of the

plunger 610 solidly seals against the oxygen inlet 210 when the door 304 is closed and latched.

Piston Drive Mechanism

5 To this point in the discussion, all of the various interfaces between the cartridge receptacle 302 and the oxygenation device 54 have been discussed with the exception of one. As mentioned previously, the oxygenation device 54 includes a piston assembly 160 that is configured to draw physiologic solution into the chamber 58 and to deliver it under pressure to the atomization chamber 62. As illustrated in Fig. 8, the plunger 164 includes a key 176
10 at one end. As mentioned during that discussion, the key 176 is configured to fit within a key slot of a device that moves the piston assembly 160 between its extended and retracted positions.

Although a variety of different mechanisms may be used to achieve this function, the
15 drive mechanism utilized in the present embodiment is illustrated in Fig. 40 and generally designated by the reference numeral 700. Generally speaking, the drive mechanism 700 includes a ball screw mechanism 702 that is driven and controlled by a motor 704. In this embodiment, the motor 704 is a stepper motor whose position is monitored by an optical encoder 706. Although the motor 704 may be directly coupled to the ball screw mechanism
20 702, a transmission 708 is used to transfer power from the motor 704 to the ball screw mechanism 702 in this embodiment. Specifically, an output shaft 710 of the motor 704 is coupled to a gear 712. The gear 712 meshes with a gear 714 that is operatively coupled to turn a screw 716. In this embodiment, the gears 712 and 714 have a drive ratio of one to one. However, any suitable drive ratio may be used.

25

As the motor 704 turns the screw 716, a "drive" assembly 718 rides up or down the screw 716 generally in the direction of the arrow 720 depending upon the direction of rotation of the screw 716. A ram 722 is slidably disposed about the screw 716 at the top of the drive assembly 718. The ram 722 includes a key way 724 that is configured to accept the
30 key 176 of the piston assembly 160. Hence, as the ram 722 moves up and down with the drive assembly 718 in response to rotation of the screw 716, it moves the piston assembly 160 back and forth within the chamber 58.

The drive assembly 718 advantageously includes a load cell 726 that is loaded as the ram 722 extends to drive the piston assembly 160 into the chamber 58. The force exerted on the load cell 726 relates to the fluid pressure within the chamber 58 when the piston assembly 160 is driving fluid out of the passageway 190. Accordingly, the reading from the load cell 726 may be used to control the speed and position of the ram 722 to ensure that fluid is delivered to the atomization chamber 62 at the desired pressure.

The components of the stepper motor assembly 700 are more clearly illustrated in the exploded view of Figs. 41A and 41B. In addition to the components previously discussed, it can be seen that the gears 712 and 714 ride on respective bearings 730 and 732. The motor 704 is mounted to one side of a bracket 734, while a shroud 736 that surrounds the drive assembly 718 is mounted on the other side of the bracket 734. It can further be seen that the screw 716 is mounted within a coupling 738 that rides on a tapered thrust bearing 740. The thrust bearing 740 is useful for accommodating the force of thrusting the ram 722 upwardly to drive the piston assembly 160 into the chamber 58.

The drive assembly 718 includes a nut 742 that is threadably coupled to a load cell mount 744. Referring additionally to the cross-sectional view of Figs. 42 and 43, the load cell mount 744 includes a slot 746 having a closed end. When the load cell mount 744 is placed within the shroud 736, the slot 746 is aligned with a set pin 748. The set pin 748 is disposed within the slot 746 to prevent the drive assembly 718 from bottoming out as it moves downwardly in response to rotation of the screw 716. Instead, the drive assembly 718 stops when the end of the slot 746 meets the set pin 748.

It should also be appreciated that the drive assembly 718 should move axially, not rotationally, in response to rotation of the screw 716. To accomplish such movement, a guide 737 is disposed on the inner wall of the shroud 736. The guide 737 interfaces with a slot 747 in the load cell mount 744 to prevent rotation of the drive assembly 718 as it moves up and down along the screw 716. Rather, because the drive assembly 718 is prevented from rotating, it moves axially relative to the screw 716.

The lower end of the ram 722 includes a flange 750. The flange 750 impinges upon the top portion of a load cell cover 752, and a lock ring 754 is coupled to the bottom of the ram 722 to fix the load cell 726 and the load cell cover 752 onto the ram 722. The load cell cover 752 is further coupled to the load cell mount 744 by a screw 756. Finally, the upper end of the ram 722 is placed through a bearing 758, and a cover plate 760 is screwed onto the top of the shroud 736.

The stepper motor assembly 700 further includes a sensor assembly 800 as illustrated in Figs. 44-48. The sensor assembly 800 provides two signals to the system controller 55. The first signal is generated when the drive assembly 718, and thus the piston assembly 160, has reached its maximum travel, i.e., its maximum extension. The second signal is provided when the drive assembly 718, and thus the piston assembly 160, reaches its home position, i.e., maximum retraction. The maximum travel signal is useful to ensure that the cap 166 of the piston assembly 160 does not bottom against the end of the chamber 58. The home position signal is useful for resetting the optical encoder 706 so that it can start monitoring the motor 704 from a known position of the drive assembly 718.

As illustrated in Figs. 44 and 46, the sensor assembly 800 includes a maximum travel sensor 802 and a home position sensor 804. In this embodiment, the sensors 802 and 804 are optical sensors. Thus, as best illustrated in Fig. 48, each of the sensors 802 and 804 includes an optical transmitter 806 and an optical receiver 808. So long as the path between the optical transmitter 806 and optical receiver 808 remains clear, the optical receiver 808 receives the optical signal transmitted from the optical transmitter 806. However, if an obstruction comes between the optical transmitter 806 and the optical receiver 808, the optical receiver 808 does not receive the optical signal sent from the optical transmitter 806. Thus, the output of the optical sensor 802 or 804 will change in this circumstance to indicate that an obstruction is present.

In the present embodiment of the sensor assembly 800, a tab or flag 810 is coupled to the load cell mount 744, as best illustrated in Fig. 47. In this embodiment, screws 812 and 814 are used to couple the flag 810 to the load cell mount 744, although any suitable mounting arrangement may be utilized. Figs. 46 and 47 illustrate the drive assembly 718 in

the home position. Accordingly, the flag 810 is positioned between the optical transmitter 806 and the optical receiver 808 of the home position sensor 804.

General System Operation

5 Now that the various mechanical components of the system 10 have been discussed, the manner in which the system 10 operates under the control of various electrical components may now be discussed. Turning now to Fig. 49, a state diagram 900 depicts the basic operation of this embodiment of the system 10.

10 When the system 10 is powered on or reset, it enters an initialization mode 902. In the initialization mode, the system controller 55 sets various system parameters and performs various diagnostic checks. For example, if the system 10 was powered down improperly the last time it was turned off, an error code may be provided. Furthermore, if the system 10 experiences a watchdog timer failure, which typically means that its processor is lost or not
15 functioning properly, the system will enter a watchdog failure mode 904.

 In the initialization mode 902, the system controller 55 also reads the cartridge present signal delivered by the sensor 520. As illustrated in Fig. 50, the cartridge present signal is processed by an IO register subsystem 906 prior to processing by the CPU 908. If
20 an oxygenation device 54 is present within the cartridge enclosure 26, the system switches from the initialization mode 902 into an unload mode 910. In the unload mode 910, the oxygenation device 54 is depressurized and the door is unlocked to allow removal of the oxygenation device 54. Removal of a used oxygenation device 54 is desirable to ensure that the same oxygenation device 54 is not used for multiple patients. To depressurize the
25 oxygenation device 54, the system controller 55 delivers an O₂ vent signal 912 to the solenoid 426 associated with the atomizer chamber 62 and a blood mixing chamber vent signal 914 to the solenoid 428 associated with the mixing chamber 64. As discussed previously, the solenoids 426 and 428 respond by retracting the respective pins 422 and 424 to enable the vent valves 258 and 260 to open. Once the oxygenation device 54 has been
30 depressurized, the system controller 55 disables a door lock signal 916 which causes the solenoid 348 to retract and withdraw the locking pin 342 from the door latch 310.

If the user does not unload the oxygenation device 54 within 30 seconds, a timeout occurs and the system 10 switches into a wait state 920, labeled wait mode 3. In the wait mode 3 state 920, an unload command will continue to be delivered so that the system 10 switches between the unload mode 910 and the wait mode 3 state 920 until the user has completed the unload operation. Then, when the oxygenation device 54 is not present, the system switches from the wait mode 3 state 920 back into the initialization mode 902.

Once initialization is complete, the system 10 switches into a wait mode 1 state 922. In the wait mode 1 state 922, the system controller 55 monitors a RS232 serial communications port 924 to await a load command from the host/user interface 66. Upon receipt of the load command, the system 10 switches into a load mode 926. The load mode 926 allows a user to install a new oxygenation device 54 and to prepare the system for priming. In the load mode 926, all valve actuation pins 382, 384, 386, 422, and 424, as well as the door lock pin 342, are retracted. Retraction of the valve actuation pins is desirable because the extended actuation pins may inhibit the oxygenation device 54 from being installed properly within the cartridge enclosure 26. To retract the respective valve actuation pins 382, 384, 386, 422, and 424, as well as the door lock pin 342, the system controller 55 delivers a fill signal 930, a flush signal 932, an AO flow signal 934, an O₂ vent signal 912, a blood mixing chamber vent signal 914, and a lock signal 916, to the solenoids 388, 390, 392, 426, 428, and 348, respectively.

Like the unload mode 910 described previously, the load mode 926 also includes a timer, such as a 30 second timeout, which causes the system 10 to revert from the load mode 926 back to the wait mode 1 state 922 if the user has not loaded the oxygenation device 54 within the allotted time. However, once the user has successfully loaded the oxygenation device 54 within the cartridge enclosure 26 as indicated by the cartridge present signal 520, the valve actuation pins 382, 384, 386, 422, and 424, as well as the door lock pin 342, are all extended so that the respective valves 202, 204, 206, 258, and 260 are held in their closed positions, and so that the latch 310 will lock when the door 304 is closed.

30

Once the door 304 has been closed and locked, the load operation is complete, and the system 10 switches from the load mode 926 into a wait mode 2 state 940. In the wait

mode 2 state 940, the system controller 55 monitors the RS232 serial communications port 924 to await either a prime command or an unload command. If the unload command is received, the system 10 transitions into the unload mode 910, which operates as previously discussed. However, if the prime command is received, the system 10 transitions into a
5 prime mode 942.

A user initiates the prime mode 942 by pressing the prime switch 108. In the prime mode 942, the system 10 fills the fluid supply chamber 58 with physiologic solution and drives the piston assembly 160 to pressurize the solution and transfer it into the atomizer
10 chamber 62 until the appropriate level of fluid is reached. In the prime mode 942, a stepper motor drive subsystem 950 of the system controller 55 reads the position of the stepper motor 704 from the encoder 706 and drives the stepper motor 704 to cause the ram 722 to push the piston assembly 160 into its fully extended position within the fluid supply chamber 58. As the piston assembly 160 is retracted, physiologic solution is drawn into the
15 fluid supply chamber 58 through the passageway 144. The piston assembly 160 then extends again to pressurize the physiologic solution within the fluid supply chamber 58 and to transfer it from the fluid supply chamber 58 into the atomizer chamber 62. In this mode, the fill valve 202 is opened, so that the fluid enters the atomizer chamber 62 through the tube 232 rather than through the atomizer 216.

20

When the system controller 55 receives the signal from the AO level sensor 480 indicating that the atomizer chamber 62 has been appropriately filled, the stepper motor driver subsystem 950 retracts the piston assembly 160 to the home position and then extends the piston assembly 160 to transfer an additional amount of solution, e.g., 3 ccs, into the
25 atomizer chamber 62. After the atomizer chamber 62 has been primed with the physiologic solution, the system controller 55 delivers an O₂ flow signal 952 to an O₂ flow solenoid 954 to open a valve 956 and allow the oxygen from the supply 60 to pressurize the atomizer chamber 62.

30 Once the proper level of fluid has been reached, the prime mode 942 is complete. However, prior to completion of the priming operation, the system 10 may transfer from the prime mode 942 to the wait mode 2 state 940 if the priming operation is interrupted by a

halt command transmitted as either a result of an error in the priming operation or as a result of the user pressing the stop switch 112.

Once the prime mode 942 is complete, the system 10 transitions into an AO off mode 960. While in the AO off mode 960, no aqueous oxygen is produced or delivered. Instead, the system controller 55 delivers a flush signal 932 to the solenoid 390 to open the flush valve 204. As previously discussed, when the flush valve 204 is open, physiologic solution flows from the fluid supply chamber 58 through the valve assembly 200 and into the mixing chamber 64 through the capillary tube 246. This mode of delivery continues so long as the blood flow through the mixing chamber 64 is above a predetermined rate, e.g., 50 ml per minute. If the blood flow drops below the predetermined rate, the system 10 transitions into a timeout mode 962. In the timeout mode 962, the system 10 does not flow, fill, or flush, and the piston assembly 160 returns to the home position. The system 10 will transition from the timeout mode 962 to the unload mode 910 if either the unload command is received from the host/user interface 66 or if the system 10 has been in the timeout mode 962 for a predetermined time, e.g., 150 seconds. However, once blood flow rises above the predetermined rate, the system 10 transitions from the timeout mode 962 back to the AO off mode 960.

When the AO on command is received, the system 10 transitions from the AO off mode 960 to an AO on mode 964. The AO on command is produced when the user presses the prime button 108 and the start button 110 simultaneously. In the AO on mode 964, the priming signal is delivered from the blood pump system 24 on a line 966 to the interlock system 44. If the system controller 55 is in the AO off mode 960 when the prime command is received, then the logic block 134 of the interlock system 44 delivers an enable signal on line 126 to enable the blood pump 24. The logic block 134 also delivers a draw clamp signal on a line 970 to the draw clamp 78 to open it while the return clamp 80 remains closed. The logic block 130 also delivers a prime signal on a line 968 to the CPU 908 of the system controller 55. In response to receiving the prime signal, the system controller 55 monitors the low level sensor 484 to determine when enough blood has flowed into the mixing chamber 64 for the chamber to be filled to the level indicated by the low level sensor 484. The low level signal is also sent to the logic block 134 of the interlock system 44 via a line

974. When the interlock system 44 determines that the chamber 64 has been filled to the level indicated by the low level sensor 484, it delivers a return clamp signal on a line 972 to the return clamp 80 to open it. Simultaneously, the system controller 55 delivers a cyclovent signal 914 to the solenoid 428 in order to close the vent valve 260.

5

The system 10 continues to operate in the AO on mode 964 in this manner unless blood flow drops below a predetermined rate, e.g., 50 ml. per minute. In this instance, the system 10 will transfer from the AO on mode 964 to the unload mode 910, which will operate as discussed previously.

10

The logic block 134 of the interlock system 44 also delivers an AO enable signal on a line 976 to the CPU 908 of the system controller 55. The AO enable signal causes the system controller 55 to deliver an AO flow signal 934 to the solenoid 392 to open the flow valve 206. As discussed previously, with the flow valve 206 opened, aqueous oxygen flows from the atomizer chamber 62 through the capillary tube 246 and into the mixing chamber 64 to be mixed with the blood.

15

Bubble Detector

As mentioned previously, the system 10 advantageously includes a bubble detector 74 that interfaces with a bubble sensor 76 to monitor the oxygen-enriched blood in the return tube 50 for bubbles. An exemplary embodiment of the bubble detector 74 is illustrated in Fig. 51. The bubble detector 74 includes a digital signal processor (DSP) 1000 that operates under software control to perform many of the functions of the bubble detector 74. The bubble detector 74 receives a return pressure signal and a flow rate signal from the interlock system 44 on lines 1002 and 1004, respectively. An analog-to-digital converter (ADC) 1006 receives these analog signals and converts them to digital signals. These digital signals are transmitted from the ADC 1006 to a microcontroller 1008. The microcontroller 1008 also receives user input from an RS-232 serial communications port 1010 from the host/user interface 66, as well as an initiate signal on line 1012 from the interlock system 44.

20

25

The DSP 1000 and the microcontroller 1008 interface with one another via interface and control logic 1014. Based on inputs from the DSP 1000 and the microcontroller 1008,

the interface and control logic 1014 delivers a transducer driver signal on line 1016 to a transducer driver 1018. In response, the transducer driver 1018 delivers a signal to the transducer 76 via line 1020. As illustrated in Fig. 52, the transmitted signal delivered by the transducer 76 includes bursts of high frequency pulses 1023A and 1023B. Each pulse burst
5 may include 20 pulses for instance at 3.6 MHz, with 50 microseconds between bursts. A return signal from the transducer 76 is received on the line 1022. The signal received from the transducer 76 on line 1022 resembles the transmitted signal 1021, but it is shifted later in time and has a smaller amplitude. It typically takes longer than one burst period for a bubble to pass by the transducer 76. Therefore, each bubble may be sampled each time a
10 pulse is delivered during the burst period, e.g., in this example, each bubble may be sampled 20 times as it travels past the transducer 76.

The strength of the received signal on the line 1022 relative to the transmitted signal on the line 1020 provides information regarding the presence of bubbles within the return
15 tube 50. As illustrated in Fig. 54, the bubble sensor 76 includes an ultrasonic transmitter 1040 and an ultrasonic receiver 1042. The bubble sensor 76 is advantageously disposed on the outside of the return tube 50. Thus, the ultrasonic signal from the transmitter 1040 is transmitted through the return tube 50, as well as any fluid within the return tube 50, to the receiver 1042. If the fluid in the return tube 50 contains no bubbles, the ultrasonic signal
20 propagates from the transmitter 1040 to the receiver 1042 in a relatively efficient manner. Thus, the signal strength of the return signal delivered by the receiver 1042 on the line 1022 is relatively strong. However, if the fluid within the return tube 50 contains bubbles 1044, as illustrated in Fig. 55, the ultrasonic signal received by the receiver 1042 will be weaker (attenuated). The poorer (attenuated) transmission of the ultrasonic signal across fluid
25 containing bubbles results from the fact that the bubbles 1044 tend to scatter the ultrasonic signal so that less of the transmitted signal is ultimately received by the receiver 1042.

As illustrated by way of example in Fig. 53, the first peak 1027A depicts a signal that was transmitted through fluid containing no bubbles, and the second peak 1027B depicts a
30 signal that was transmitted through fluid containing bubbles. The relative weakness of the peak 1027B is demonstrated by a reduction in the peak 1027B. The extent of the reduction (attenuation) in the peak 1027B is related to the diameter of the bubble passing through the

bubble sensor 76 at the time the signal was transmitted. Specifically, the amount of the reduction (attenuation) 1046 in the signal is related to the bubble's cross-sectional area and thus the square of the diameter of the bubble, so that the square root of the signal is directly proportional to the size of the bubble, respectively the diameter thereof.

5

To facilitate processing of the return signal, it is delivered to a signal conditioner 1024. The signal conditioner 1024 amplifies and filters the return signal. The signal conditioner 1024 then detects the amount of ultrasonic energy of the signal and transmits it to an analog to digital converter (ADC) 1026. A signal 1025 delivered to the ADC 1026 is
10 illustrated in Fig. 53. As can be seen from a study of the signal 1025, each of the high frequency pulse trains 1023A and 1023B now resembles a single peak 1027A and 1027B, respectively. The ADC 1026 samples only the peaks 1027A and 1027B in the amplitude signal 1025. In this example, each peak 1027A and 1027B is approximately 6.6 microseconds in width, and the ADC 1026 samples 128 peaks to establish 128 data points.

15

The digitized output of the ADC 1026 is delivered to a buffer, such as a first-in/first-out (FIFO) buffer 1030. The buffer 1030 stores the digitized representations of 128 peaks and delivers them one by one to the DSP 1000. The interface and control logic 1014 controls delivery of the signals from the buffer 1030 to the DSP 1000.

20

The DSP 1000 reads the data points for each of the digitized peaks and sums them together. The sum of the digitized peaks correlates to the amount of ultrasonic energy received. In this embodiment, the DSP 1000 maintains a running average of the sum of the last 16,000 or more peaks. The current sum is subtracted from the average to provide a
25 high pass filter which effectively removes any DC offset. The DSP 1000 also performs a low pass filter operation by convolving the resulting signal through an FIR array. In this example, the FIR array is a 64 point array. The filtering is performed to ensure that the bubbles are discriminated from the noise in the signals. The resulting signals of different sized bubbles is illustrated in Fig. 61.

30

Once the DSP 1000 determines the diameter of each bubble detected, it calculates the volume of the bubble. However, it should be understood that the volume of the bubble

delivered to the patient 38 is affected by the pressure of the fluid within the return tube 50. Because the pressure of the fluid within the return tube 50 is typically higher, e.g., approximately two to three atmospheres, as compared to the blood within the patient's vessels, e.g., approximately one atmosphere, a conversion is advantageously performed to determine the volume of the bubble once it reaches the patient 38. Since the pressure in the return tube 50 is delivered to the bubble detector 74 on the line 1002, and since the pressure of the patient's blood can be assumed to be one atmosphere using the ideal gas law, the volume of the bubble at the patient equals $V_p = (P_s \cdot V_s) / P_a$, where V_p is the volume of the bubble at the patient 38, P_s is the pressure at the bubble sensor 76, V_s is the volume of the bubble at the bubble sensor 76, and P_a is atmospheric pressure.

The DSP 1000 advantageously places bubbles of certain sizes in appropriate "bins" or categories. In other words, the DSP 1000 may maintain different categories of bubble sizes. For example, the categories may include sixteen bins of 75 micron diameter increments. The number of bubbles in each category may be transmitted to the display 32 so that a user can monitor the number and size of bubbles being produced during the surgical procedure. The number and size of bubbles also may be monitored by the bubble detector 74 or elsewhere within the system 10 to monitor the operation of the system 10.

The bubble detector 74 also may accumulate total volume of all bubbles detected over time, i. e. add the volume of each bubble to a running total. If the accumulated volume or running total exceeds a prescribed volume within a prescribed time, then operation of the system 10 may be altered. For example, if the total volume of bubbles exceeds 10 microliters in a 90 minute period, the bubble detector 74 may deliver a "request to stop" signal on a line 1050. In this embodiment, the request to stop signal is received by the interlock system 44, so that the interlock system 44 can shut down the system 10 as previously described. Since most patients typically resolve small volumes of gas over time, the running total may be decremented as the procedure progresses so that the predetermined limit which triggers shut down of the system 10 will not be reached as rapidly. In addition, prior to reaching the predetermined limit, the bubble detector 74 may provide an early warning of an impending shut down so that the system controller 55 can lower the pO_2 level of the blood in the return tube 50 to curtail bubble production and, thus, avoid shutdown.

Bubble Detector Evaluation or Calibration

Individual ultrasonic probes may have varying degrees of resolution. Therefore, a limitation on the bubble detector's ability to detect bubbles may arise when the size and/or velocity of some bubbles are beyond the resolution of the probe. Depending on the circumstances, it is possible that microbubbles (bubbles with diameters of about 50 μm to about 1000 μm) and/or macrobubbles (bubbles with diameters greater than 1000 μm) may escape detection. When bubbles escape detection, the accuracy of the bubble detector may be compromised.

Thus, it may be desirable to utilize a system and method for evaluating the bubble detection capabilities of a bubble detector. The system and method of evaluation described below is capable of determining the microbubble and macrobubble resolution of the bubble detector at a plurality of flow rates and material viscosities. Generally speaking, bubbles of a determinable size are introduced into a flow material. The size and quantity of bubbles introduced into the flow material are measured by the bubble detector under evaluation. Thereafter, the size and quantity of bubbles introduced into the flow material are determined independently.

An exemplary embodiment of a calibration and evaluation system 1105 for bubble detectors, such as the bubble detector 74, is illustrated in Fig. 56. The system and method permits a practitioner to control the bubble size, rate of bubble production, and the rate of flow of flow material. The system 1105 employs a containment vessel 1110 for storing a flow material 1112. The vessel 1110 includes an inlet 1116 and outlet 1118 so that the flow material 1112 travels generally in the direction of the arrow 1119. A pump 1120, such as a peristaltic pump, is utilized to induce and maintain a desired flow rate. Advantageously, the pump 1120 is capable of transmitting the flow material 1112 at a plurality of flow rates. Flow materials 1112 of varying viscosity may be utilized and may include newtonian or non-newtonian fluids. Typically, the viscosity of the flow material 1112 used for evaluation is comparable with the viscosity of the material utilized in the operational environment, e.g., blood mixed with gas-enriched physiologic fluid in this example.

The system 1105 employs a first conduit 1130, typically of predetermined internal diameter and predetermined length, having a proximal end 1132 and distal end 1134, through which the flow material 1112 may be passed at various rates. The proximal end 1132 is coupled to the outlet 1118 to receive the flow material 1112 from the vessel 1110.

5 The distal end 1134 is coupled to a connecting device 1140. The connecting device 1140, for example a T-connector, is typically positioned along the longitudinal axis of the first conduit 1130 and in fluid communication therewith to permit the continued unimpeded flow of the flow material 1112.

10 A bubble-forming device 1143 may be used to induce bubble formation in the flow material 1112 through the introduction of a bubble-forming material 1150. The bubble-forming material 1150 typically includes a gas, such as air. The flow material 1112 may contain a surfactant, such as sodium dodecyl sulfate (SDS), to promote bubble formation and retention.

15 As best illustrated in Figs. 57 and 58, the bubble-forming device 1143 in this example includes a bubble-forming capillary 1144, which is typically of predetermined internal diameter and predetermined length. The capillary 1144 has a proximal end 1146 and a distal end 1148. The proximal end 1146 is attached by a bubble-forming lumen 1153

20 to a bubble-pumping device 1155, such as a syringe. The bubble-pumping device 1155 is typically capable of injecting the bubble-forming material 1150 into the flow material 1112 at various injection rates. The distal end 1148 of the capillary 1144 is slidably arranged to be located within the interior of the connecting device 1140 incident to the flow material 1112, thus resulting in the generation of bubbles within the flow material 1112. In this example,

25 the capillary 1144 is positioned perpendicular or nearly perpendicular to the longitudinal axis of the direction of flow of the flow material 1112 so that the resultant shear force of the flow generates bubbles of a uniform size at a constant rate.

Bubble size may be regulated by the internal diameter of the capillary 1144 or by

30 positioning the distal portion 1148 of the capillary 1144 at various positions within the material flow. Increasing the internal diameter of capillary 1144 increases bubble size. Similarly, positioning the distal portion 1148 of the capillary 1144 away from the

longitudinal axis of the flow material 1112 increases bubble size. The rate of bubble formation may be varied by increasing or decreasing the flow rate of the bubble-forming material 1150 introduced into the flow material 1112. For example, an increase in the flow rate of the bubble-forming material 1150 increases the rate of bubble formation in the flow material 1112.

The system 1105 further employs a second conduit 1170, which is typically of predetermined internal diameter and predetermined length. A proximal end 1172 of the second conduit 1170 is coupled to the connecting device 1140, and a distal end 1174 of the second conduit 1170 is coupled to the inlet 1116 of the containment vessel 1110. To maintain a substantially constant flow rate in the conduits 1130 and 1170, the second conduit 1170 is usually coaxially aligned with the first conduit 1130, and the diameter of the second conduit 1170 is usually equivalent to the diameter of the first conduit 1130. The probe 76 of the bubble detector 74 to be evaluated is positioned proximal to the second conduit 1170 to enable detection of bubbles within the flow material 1112 passing through the second conduit 1170.

The connecting device 1140 may be optically transparent to permit visual inspection of the bubble generation process. Indeed, a recording device 1160, such as a CCD camera, may be focused on the distal end 1148 of the capillary 1144 to observe and record the size and quantity of bubbles within the flow material 1112. Thus, bubble detectors, such as the bubble detector 74 for example, may be calibrated by comparing the size and quantity of bubbles detected by the probe 76 with the size and quantity of the bubbles measured by the recording device 1160. A second examining device (not shown) may be positioned along second conduit 1170 between the bubble detector probe 76 and the inlet 1116 of the containment vessel 1110 to provide the practitioner access to the flow material 1112.

In operation, flow is initiated by activating the pump 1120. The flow rate of the flow material 1112 is permitted to stabilize before introducing bubbles to the system 1105. Once the system 1105 has stabilized, bubbles are introduced to the flow material 1112 by activating the bubble-forming device 1143. The system 1105 is permitted to stabilize once again before calibrating the bubble detector 74.

The microbubble resolution of the bubble detector 74 may be determined by introducing bubbles of successively smaller diameters in successive tests. The macrobubble resolution of the bubble detector 74 may be determined in a similar manner by introducing
5 bubbles of successively larger diameters in successive tests. Once the rate of bubble generation and flow rate have stabilized, the recording device 1160 is activated to record the rate of bubble generation and the size of the bubbles generated. The bubble detector 74 to be evaluated is activated for a predetermined amount of time.

10 The probe 76 examines the bubbles which are generally of known size and quantity, and the probe 76 delivers corresponding signals to the bubble detector 74. The size and quantity of bubbles recorded by the bubble detector 74 are compared to the size and quantity of the bubbles recorded by the recording device 1160. Typically, such comparison is performed at a plurality of signal strengths and bubble sizes. Thereafter, one skilled in the
15 art of mathematics may graphically represent this relationship and extrapolate the projected signal strengths at a plurality of bubble sizes. When the signal- to-bubble size relation is graphically plotted, one skilled in the art of mathematics can calculate one or more calibration constants based on the fit of the signal strength to bubble size relationship. The calibration constant(s) can be programmed into the bubble detector 74 to calibrate the
20 bubble detector 74.

An alternative embodiment of the calibration and evaluation system 1105 is identical to the previously described system except for the incorporation of a pulse dampener 1180, as
25 illustrated in Fig. 59. The pulse dampener 1180 reduces or eliminates pressure oscillations produced by the pump 1120. Relatively large bubbles that may be produced by such pressure oscillations and/or recirculated within the flow circuit become trapped within the pulse dampener 1180 so that they do not disturb the controlled formation of bubbles by the bubble-forming device 1143.

30 As shown with further reference to Fig. 60, the pulse dampener 1180 comprises a vessel body 1181 having an inlet 1182 and an outlet 1184. The inlet 1182 is coupled in the first conduit 1130 between the pump 1120 and the connecting device 1140. The pump

1120 forces the flow material 1112 into the vessel body 1181 through the inlet 1182. The pressure exerted by the pump 1120 is maintained within the vessel body 1181, thus forcing the flow material 1112 through the outlet 1184. Thus, any bubbles produced by the pump 1120 are trapped prior to reaching the connecting device 1140.

5

While the invention may be susceptible to various modifications and alternative forms, specific embodiments have been shown by way of example in the drawings and have been described in detail herein. However, it should be understood that the invention is not intended to be limited to the particular forms disclosed. Rather, the invention is to cover all
 10 modifications, equivalents, and alternatives falling within the spirit and scope of the invention as defined by the following appended claims.

REFERENCE NUMERALS

15	10	system for preparing and delivering gas-enriched fluid
	12	rolling base
	14	pedestal
	16	housing
	18	handle
20	20	pedal
	24	blood pump
	26	cartridge enclosure
	28	control devices
	30	user interface panel
25	32	display
	34	draw tube
	36	blood vessel
	38	patient
	40	(peristaltic) pump
30	42	arrow
	44	interlock system
	46	flow meter

	48	flow probe/ transducer
	50	patient's return tube
	54	oxygenation device
	55	system controller
5	56	supply
	58	first chamber /fluid supply chamber
	60	supply
	62	second chamber/ atomization chamber
	64	third chamber / mixing chamber
10	66	host/user interface
	68	draw pressure sensor
	70	return pressure sensor
	71	Y-connector
	73	electrical connector
15	74	bubble detector
	76	bubble sensor
	78	clamps
	80	clamps
	82	safety switch
20	84	user interface
	85	host interface
	86	touch screen display
	87	buttons
	88	alarms/messages
25	89	status indicators
	90	blood flow information
	91	bubble count
	92	touch screen driver
	93	display driver
30	94	RS-232 interface
	95	display controller
	96	bus

	97	sound card
	98	speakers
	101	analog and/or digital I/O device
	104	“up” button
5	106	“down” button
	108	“prime” button
	110	“start” button
	112	“stop” button
	114	foot switch
10	116	stop pedal
	118	prime start pedal
	120	personality module
	122	memory
	124	line
15	130	analog conditioning circuit
	132	comparators and threshold settings
	134	logic block
	140	tube
	142	nozzle
20	144	fluid passageway
	148	O-ring seal
	150	spring
	152	ball
	154	arrow
25	160	piston assembly
	162	sleeve
	164	plunger
	166	cap
	168	flange
30	170	relatively resilient end piece
	172	sealing members
	174	free end

- 176 key
178 narrow portion
180 wider portion
182 sterility sheath
5 184 extendable tube
186 clamp
190 second fluid passageway
192 check valve
194 fluid passageway
10 196 tube
200 valve assembly
202 fill valve
204 flush valve
206 flow valve
15 210 passageway
212 passageway
214 passageway
216 atomizer
218 central passageway
20 220 one-way valve
222 nozzle

230 passageway
232 tube
25
240 passageways
242 passageways
246 capillary tube
248 tip
30 250 blood inlet
252 exit nozzle
256 compartment

	258	vent valve
	260	vent valve
	262	plunger
	264	O-ring seal
5	266	spring
	302	cartridge receptacle
	304	hinged door
	308	surface
10	310	door latch
	312	handle portion
	314	latching portion
	316	pivot pin
	318	arrow
15	320	latch pin
	322	biasing mechanism
	324	pin
	326	pin
	328	wall
20	330	spring
	332	spring
	334	arrow
	340	locking mechanism
25	342	slidable pin
	344	arrow
	346	piston
	348	pull-type solenoid
	350	spring
30	352	arrow
	354	portion

	360	sensor
	362	magnet
	380	slot
5	382	actuation pin
	384	actuation pin
	386	actuation pin
	388	solenoid
	390	solenoid
10	392	solenoid
	394	lever
	396	lever
	398	lever
	400	fulcrum or pivot pin
15	402	fulcrum or pivot pin
	404	fulcrum or pivot pin
	406	piston
	408	spring
	410	arrow
20	412	arrow
	414	arrow
	416	arrow
	420	slot
	422	pin
25	424	pin
	426	solenoid
	428	solenoid
	430	solenoid
	432	solenoid
30	434	fulcrum or pivot pin
	436	fulcrum or pivot pin
	440	spring

- 442 arrow
- 444 piston
- 446 arrow
- 448 arrow
- 5
- 480 AO level sensor
- 482 high level sensor
- 484 low level sensor
- 10
- 490 ultrasonic transducer element
- 492 channel
- 494 sensor body
- 496 sleeve
- 498 wall
- 15
- 500 external screw threads
- 502 bushing
- 504 annular flange
- 512 resilient member
- 20
- 514 flat contact portion
- 516 flat contact portion
- 520 cartridge present sensor
- 522 opening
- 524 flat section
- 25
- 540 external temperature sensor
- 542 opening
- 600 flow valve
- 30
- 602 pressure transducer
- 604 check valve
- 606 tee

- 608 line
- 610 plunger
- 612 port
- 614 bushing or sleeve
- 5 616 recessed area
- 618 spring
- 622 slanted or cammed portion
- 624 slanted or cammed portion
- 626 rod
- 10 630 arrow
- 632 spring
- 634 arrow
- 638 adjustment screw
- 640 abutment portion
- 15
- 700 drive mechanism
- 702 ball screw mechanism
- 704 motor
- 706 optical encoder
- 20 708 transmission
- 710 output shaft
- 712 gear
- 714 gear
- 25 730 bearing
- 732 bearing
- 734 bracket
- 736 shroud
- 737 guide
- 30 738 coupling
- 740 tapered thrust bearing
- 744 load cell mount

	748	set pin
	750	flange
	752	load cell cover
	754	lock ring
5	756	screw
	758	bearing
	760	cover plate
	800	sensor assembly
10	802	maximum travel sensor
	804	home position sensor
	806	optical transmitter
	808	optical receiver
	810	tab or flag
15		
	1000	digital signal processor (DSP)
	1002	line
	1004	line
	1006	analog-to-digital converter (ADC)
20	1008	microcontroller
	1010	RS-232 serial communications port
	1012	line
	1014	interface and control logic
	1018	transducer driver
25	1020	line
	1021	transmitted signal
	1022	line
	1024	signal conditioner
	1026	ADC
30		
	1030	buffer

- 1040 ultrasonic transmitter
- 1042 ultrasonic receiver
- 1044 bubbles
- 1046 reduction
- 5
- 1105 calibration and evaluation system
- 1110 containment vessel
- 1112 flow material
- 1116 inlet
- 10 1118 outlet
- 1120 pump
- 1130 first conduit
- 1132 proximal end
- 1134 distal end
- 15 1140 connecting device
- 1143 bubble-forming device
- 1144 bubble-forming capillary
- 1146 proximal end
- 1148 distal end
- 20 1150 bubble-forming material
- 1155 bubble-pumping device
- 1160 recording device
- 1170 second conduit
- 1180 pulse dampener
- 25 1181 vessel body
- 1182 inlet
- 1184 outlet

CLAIMS

What is claimed is:

1. A system for enriching a bodily fluid with a gas, the system comprising:
5 a pump system (24) adapted to transmit a bodily fluid from a patient;
a gas-enriching device operatively coupled to the pump system (24) to receive the
bodily fluid, the gas-enriching device combining the bodily fluid with a gas to form a gas-
enriched bodily fluid;
a bubble detector (74) arranged to detect bubbles in the gas-enriched bodily fluid;
10 and
a controller (28) adapted to control the pump system (24) and the gas-enriching
device automatically.
2. The system, as set forth in claim 1, wherein the pump system (24) comprises:
15 a pump (40) adapted to pump the bodily fluid through a tube (34); and
a flow meter (46) adapted to sense flow of the bodily fluid through the tube (34), the
flow meter (46) generating an actual flow rate signal correlative to flow through the tube
(34), wherein the controller (28) is operatively coupled to the pump (40) and to the flow
meter (46), the controller (28) adapted to receive the actual flow rate signal and to control
20 the pump (40) to maintain a desired rate of flow through the tube (34).
3. The system, as set forth in claim 2, wherein the pump comprises:
a peristaltic pump (40).
- 25 4. The system, as set forth in claims 2 - 3, wherein the flow meter (46)
comprises:
a flow transducer (48) adapted to be operatively coupled to the tube (34), the flow
transducer (48) adapted to deliver to the flow meter (46) a flow signal correlative to flow
through the tube (34).
30
5. The system, as set forth in claims 2 - 4, comprising:

a flow setting device operatively coupled to the pump (40) to set the desired rate of flow through the tube (34).

5 6. The system, as set forth in claim 5, wherein the flow setting device comprises:
a display (32) illustrating the desired flow rate; and
a user-actuatable input operatively coupled to the display (32) to adjust the desired flow rate illustrated by the display (32).

10 7. The system, as set forth in claim 5, wherein the flow setting device comprises:
a personality module having a memory adapted to store the desired flow rate and to deliver the desired flow rate signal to the controller (28).

15 8. The system, as set forth in claim 7, wherein the desired flow rate stored in the personality module comprises a desired range of flow rates.

 9. The system, as set forth in claims 1 - 8, wherein the gas-enriching device comprises a disposable cartridge adapted to be placed in an enclosure.

20 10. The system, as set forth in claim 9, wherein the cartridge comprises:
a housing (16);
an enrichment device disposed in the housing (16) to form a gas-enriched physiologic fluid; and
a mixing device disposed in the housing (16) to mix the gas-enriched physiologic fluid with the bodily fluid to form the gas-enriched bodily fluid.

25 11. The system, as set forth in claim 10, wherein the enrichment device comprises:
an atomizing chamber (62) adapted to receive the gas through a gas inlet; and
an atomizer (216) disposed within the atomizing chamber (62), the atomizer (216)
30 adapted to receive physiologic fluid and to atomize the physiologic fluid upon delivery into the atomizing chamber (62) to form the gas-enriched physiologic fluid.

12. The system, as set forth in claims 10 - 11, wherein the mixing device comprises:

a mixing chamber (64) having a fluid inlet and a fluid outlet; and

5 a fluid delivery device disposed within the mixing chamber (64) in a predetermined relationship with the fluid inlet, the fluid delivery device adapted to receive the gas-enriched physiologic fluid from the atomizing chamber (62) and to deliver the gas-enriched fluid into the mixing chamber (64) to mix with the bodily fluid entering the mixing chamber (64) through the fluid inlet to form the gas-enriched bodily fluid.

10 13. The system, as set forth in claims 10 - 12, wherein the cartridge comprises:

a fluid supply device disposed in the housing (16) to supply a physiologic fluid to the enrichment device.

15 14. The system, as set forth in claim 13, wherein the fluid supply device comprises:

a fluid supply chamber (58) having a fluid inlet and a fluid outlet; and

20 a pump (40) disposed within the fluid supply chamber (58), the pump (40) adapted to draw a physiologic fluid into the fluid supply chamber (58) through the fluid inlet in the fluid supply chamber(58) and to deliver the physiologic fluid to the enrichment device through the fluid outlet in the fluid supply chamber (58).

15. The system, as set forth in claims 13 - 14, wherein the cartridge comprises:

25 a valve assembly disposed in the housing (16), the valve assembly having valves to control flow of the physiologic fluid between the fluid supply device and the enrichment device and to control flow of the gas-enriched physiologic fluid between the enrichment device and the mixing device.

16. The system, as set forth in claims 10 - 15, wherein the enclosure comprises:

a receiving chamber sized to accept the cartridge therein;

30 a first level sensor arranged to determine fluid level in the enrichment device;

a second level sensor arranged to determine a low fluid level in the mixing device;

and

a third level sensor arranged to determine a high fluid level in the mixing device.

17. The system, as set forth in claims 15 - 16, wherein the enclosure (26) comprises:

- 5 a receiving chamber sized to accept the cartridge therein; and
a valve actuation assembly adapted to actuate the valves of the valve assembly.

18. The system, as set forth in claims 9 - 17, wherein the enclosure (26) comprises:

- 10 a door (304) having a lock (340) to secure the cartridge within the enclosure.(26)

19. The system, as set forth in claims 1 - 18, wherein the bubble detector (74) comprises:

- an ultrasonic transducer pair comprising a transmitting transducer (1040) and a
15 receiving transducer (1042), the ultrasonic transducer pair being positionable to sense
bubbles (1044) in a fluid flow;

a transducer driver (1018) operatively coupled to the transmitting transducer (1040)
to cause the transmitting transducer (1040) to deliver a pulsed ultrasonic signal across the
fluid flow to the receiving transducer (1042);

- 20 a signal conditioner (1024) operatively coupled to the receiving transducer (1042) to
receive the pulsed ultrasonic signal from the receiving transducer (1042), the signal
conditioner (1024) conditioning the pulsed ultrasonic signal to produce a conditioned
signal; and

25 a signal processor (1000) operatively coupled to the signal conditioner (1024) to
receive the conditioned signal, the signal processor (1000) determining information
correlative to bubbles (1044) in the fluid flow in response to the conditioned signal.

20. The system, as set forth in claim 19, wherein the pulsed ultrasonic signal
delivered by the transmitting transducer (1040) comprises a frequency range of 3 MHz to 4
30 MHz and a pulse rate of about 3 KHz to 40 KHz .

21. The system, as set forth in claims 19 - 20, wherein the signal conditioner (1024) comprises:

a detector adapted to detect the amount of ultrasonic energy of the pulsed ultrasonic signal received by the receiving transducer (1042).

5

22. The system, as set forth in claims 19 - 21, wherein the signal conditioner (1024) comprises:

an analog-to-digital converter (1006) adapted to convert the amount of ultrasonic energy detected by the detector into a digital signal.

10

23. The system, as set forth in claims 19 - 22, wherein the signal processor (1000) comprises a buffer (1030) adapted to hold multiple digital signals.

24. The system, as set forth in claim 23, wherein a reduction (1046) in the digital signal as compared to previously recorded digital signals or an average of previously recorded digital signals is correlative to bubbles (1044) in the fluid flow.

15

25. The system, as set forth in claims 19 - 24, wherein the signal processor (1000) comprises a digital signal processor (1000).

20

26. The system, as set forth in claim 25, wherein the digital signal processor (1000) is adapted to detect and count each bubble (1044) in the fluid flow.

27. The system, as set forth in claims 25 - 26, wherein the digital signal processor (1000) determines the volume of each bubble (1044) in the fluid flow.

25

28. The system, as set forth in claim 27, wherein the digital signal processor (1000) converts the volume of each bubble (1044) in the fluid flow to a volume of each bubble (1044) when it reaches a patient (38).

30

29. The system, as set forth in claims 25 - 28, wherein the digital signal processor (1000) determines an accumulated volume of bubbles (1044) in the fluid flow over a given period of time.

5 30. The system, as set forth in claim 29, wherein the signal processor (1000) initiates the stop signal in response to the accumulated volume of bubbles exceeding a predetermined limit, the stop signal being delivered to the controller (28) to cause the controller (28) to cease operation of the pump system (24) and the gas-enriching device.

10 31. The system, as set forth in claims 1 - 30, wherein the controller comprises:
a first sensor assembly arranged to monitor the pump system (24), the first sensor assembly delivering at least one first signal correlative to operation of the pump system (24);
a second sensor assembly arranged to monitor the gas-enriching device, the second sensor assembly delivering at least one second signal correlative to operation of the gas-enriching device;
15 a signal processor (1000) operatively coupled to the first sensor assembly and to the second sensor assembly to receive the at least one first signal and the at least one second signal, the signal processor (1000) delivering at least one pump system control signal in response to the at least one first signal, the pump system (24) adjusting its operation in
20 response to receiving the at least one pump system control signal from the signal processor (1000), and the signal processor (1000) delivering at least one gas-enrichment control signal in response to the at least one second signal; and
an actuation assembly arranged to adjust operation of the gas-enriching device in response to receiving the at least one gas-enrichment signal from the signal processor (1000).

25 32. The system, as set forth in claim 31, wherein the first sensor assembly comprises:
a flow transducer adapted to be operatively coupled to a tube carrying the bodily fluid, wherein the at least one first signal comprises a flow signal delivered from the flow
30 transducer, the flow signal being correlative to flow through the tube.

33. The system, as set forth in claim 32, wherein the signal processor (1000) comprises a comparison device adapted to receive the flow signal and to compare the flow through the tube to the desired flow range.

5 34. The system, as set forth in claim 33, wherein the signal processor (1000) delivers an enable signal to the pump system (24) in response to the flow signal being indicative of flow through the tube being within a desired flow range.

10 35. The system, as set forth in claim 33, wherein the signal processor (1000) delivers a disable signal to the pump system (24) in response to the flow signal being indicative of flow through the tube being outside the desired flow range.

36. The system, as set forth in claims 33 - 35, comprising:
a first clamp (78) adapted to be operatively coupled to a draw side of the tube (34);
15 and
a second clamp (80) adapted to be operatively coupled to a return side of the tube (34), wherein the signal processor (1000) closes the first clamp (78) and the second clamp (80) in response to the flow signal being outside the desired flow range.

20 37. The system, as set forth in claims 31 - 36, wherein the gas-enriching device comprises a cartridge adapted to be disposed in an enclosure (26), wherein the cartridge comprises:

a housing (16);
a fluid supply device disposed in the housing (16) to supply a physiologic fluid;
25 an enrichment device disposed in the housing (16) and operatively couple to receive the physiologic fluid from the fluid supply device, the enrichment device converting the physiologic fluid to a gas-enriched physiologic fluid;
a mixing device disposed in the housing (16) and operatively coupled to receive the gas-enriched physiologic fluid from the enrichment device and to receive the bodily fluid
30 from the pump system (24), the mixing device adapted to mix the gas-enriched physiologic fluid with the bodily fluid to form the gas-enriched bodily fluid; and

a valve assembly disposed in the housing (16), the valve assembly having valves to control flow of the physiologic fluid between the fluid supply device and the enrichment device and to control flow of the gas-enriched physiologic fluid between the enrichment device and the mixing device;

5 and wherein the second sensor assembly comprises:

a transducer arranged to determine physiologic fluid supplied by the fluid supply device;

a first level sensor arranged to determine fluid level in the enrichment device;

a second level sensor arranged to determine a low fluid level in the mixing device;

10 and

a third level sensor arranged to determine a high fluid level in the mixing device;

and wherein the actuation assembly comprises:

a valve actuation assembly disposed in the enclosure (26) and adapted to actuate the valves of the valve assembly.

15

38. A method of enriching a bodily fluid with a gas, the method comprising the acts of:

(a) supplying a physiologic fluid to a cartridge;

20 (b) enriching the physiologic fluid with a gas in the cartridge to form a gas-enriched physiologic fluid; and

(c) mixing the gas-enriched physiologic fluid with a bodily fluid in the cartridge to form a gas-enriched bodily fluid.

39. The method, as set forth in claim 38, wherein act (a) comprises the act of:

25 pressurizing the physiologic fluid within the fluid supply chamber (58) of the cartridge.

40. The method, as set forth in claim 39, wherein the act of pressurizing comprises the act of:

30 forcing a piston (160) against the physiologic fluid within the fluid supply chamber (58).

41. The method, as set forth in claims 38 - 40, wherein act (b) comprises the act of:

atomizing the physiologic fluid within an atomization chamber (62) of the cartridge.

5 42. The method, as set forth in claim 41, wherein act (b) comprises the act of:
transferring the physiologic fluid from a fluid supply chamber (58) of the cartridge to the atomization chamber (62).

10 43. The method, as set forth in claims 38 - 42, wherein act (c) comprises the act of:

transferring the gas-enriched physiologic fluid into a mixing chamber (64) of the cartridge in a substantially bubble-free manner.

15 44. The method, as set forth in claim 43, wherein the act of transferring comprises the act of:

passing the gas-enriched physiologic fluid through a capillary (246).

45. A method of operating an extracorporeal circuit, the method comprising the acts of:

- 20 (a) loading a cartridge into an enclosure (26);
(b) priming the cartridge with a physiologic solution;
(c) priming the cartridge with a bodily fluid;
(d) enriching the physiologic solution with a gas to form a gas-enriched physiologic fluid;
25 (e) mixing the gas-enriched physiologic fluid with the bodily fluid to form a gas-enriched bodily fluid; and
(f) delivering the gas-enriched bodily fluid to a patient (38).

30 46. The method, as set forth in claim 45, wherein act (a) comprises the act of:
retracting valve actuation pins (382, 384, 386) within the enclosure (26) prior to placing the cartridge within the enclosure (26).

47. The method, as set forth in claim 46, wherein act (a) comprises the act of:

extending the valve actuation pins (382, 384, 386) after placing the cartridge within the enclosure (26).

5

48. The method, as set forth in claims 46 - 47, wherein act (a) comprises the act

of:

locking the cartridge within the enclosure (26).

10

49. The method, as set forth in claims 45 - 48, wherein act (b) comprises the act

of:

pressurizing the physiologic solution.

15

50. The method, as set forth in claims 46 - 49, wherein act (b) comprises the acts

of:

drawing the physiologic solution into a fluid supply chamber (58) of the cartridge;

pumping the physiologic solution from the fluid supply chamber (58) into an atomization chamber (62) of the cartridge; and

supplying the gas to the atomization chamber (62).

20

51. The method, as set forth in claims 45 - 50, wherein act (c) comprises the acts

of:

opening a clamp (78, 80) on a draw side of a tube (34) carrying the bodily fluid;

pumping the bodily fluid into a mixing chamber (64) of the cartridge until the bodily fluid reaches a predetermined level within the mixing chamber (64); and

25

opening a clamp (78, 80) on a return side of the tube (34).

52. The method, as set forth in claims 45 - 51, wherein act (d) comprises the act

of:

atomizing the physiologic fluid within an atomization chamber (62) of the cartridge.

30

53. The method, as set forth in claim 52, wherein act (d) comprises the act of:

coupling a supply of the gas to the atomization chamber (62).

54. The method, as set forth in claim 53, wherein act (d) comprises the act of:
transferring the physiologic fluid from a fluid supply chamber (58) of the cartridge to
5 the atomization chamber (62).

55. The method, as set forth in claims 45 - 54, wherein act (e) comprises the act
of:
transferring the gas-enriched physiologic fluid into a mixing chamber (64) of the
10 cartridge in a substantially bubble-free manner.

56. The method, as set forth in claim 55, wherein the act of transferring
comprises the act of:
passing the gas-enriched physiologic fluid through a capillary (246).

15 57. The method, as set forth in claims 45 - 56, wherein act (f) comprises the act
of:
passing the gas-enriched bodily fluid through a catheter.

20 58. An automated blood pump circuit comprising:
a blood pump (24) adapted to pump blood through a tube (34);
a flow meter (46) adapted to sense blood flow through the tube (34), the flow meter
(46) generating an actual flow rate signal correlative to blood flow through the tube (34);
and
25 a controller operatively coupled to the blood pump (24) and to the flow meter (46),
the controller adapted to receive the actual flow rate signal and to control the blood pump
(24) to maintain a desired rate of blood flow through the tube (34).

30 59. The circuit, as set forth in claim 58, wherein the blood pump (24) comprises:
a peristaltic pump (40).

60. The circuit, as set forth in claims 58 - 59, wherein the flow meter (46) comprises:

5 a flow transducer adapted to be operatively coupled to the tube (34), the flow transducer adapted to deliver to the flow meter (46) a flow signal correlative to blood flow through the tube (34).

61. The circuit, as set forth in claims 58 - 60, comprising:

10 a flow setting device operatively coupled to the blood pump (24) to set a desired rate of blood flow through the tube (34).

62. The circuit, as set forth in claim 61, wherein the flow setting device delivers a desired flow rate signal to the controller (28), and wherein the controller (28) automatically adjusts the actual rate of flow through the tube (34) to the desired flow rate in response to the desired flow rate signal and the actual flow rate signal.

15

63. The circuit, as set forth in claim 62, wherein the flow setting device comprises:

a display adapted to generate the desired flow rate signal correlative to the desired rate of blood flow through the tube (34).

20

64. The circuit, as set forth in claim 63, wherein the display (32) comprises:

a digital panel (30) illustrating the desired flow rate; and

a user-actuatable input operatively coupled to the digital panel (30) to adjust the desired flow rate illustrated by the digital panel (30).

25

65. The circuit, as set forth in claims 62 - 64, wherein the flow setting device comprises:

30 a personality module having a memory adapted to store the desired flow rate and to deliver the desired flow rate signal to the controller (28).

66. The circuit, as set forth in claim 65, wherein the desired flow rate stored in the personality module comprises a desired range of flow rates.

5 67. The circuit, as set forth in claims 61 - 66, wherein the tube (34) has a draw portion for drawing blood from a patient (38) and a return portion for returning blood to a patient (38), the circuit comprising:

a draw tube clamp (78) operatively coupled to the draw portion of the tube (34), the draw tube clamp (78) being moveable between a clamped position and an unclamped position;

10 a return tube clamp (80) operatively coupled to the return portion of the tube (34), the return tube clamp (80) being moveable between a clamped position and an unclamped position; and

wherein the controller (28) is operatively coupled to the draw tube clamp (78) and the return tube clamp (80), the controller (28) adapted to move the draw tube clamp (78) and the return tube clamp (80) between the respective clamped and unclamped positions.

15

68. The circuit, as set forth in claim 67, wherein the blood pump circuit comprises:

an extracorporeal circuit.

20

69. A method of priming a blood pump circuit, the circuit having a tube (34) having a draw portion for drawing blood from a patient (38) and having a return portion for returning blood to a patient (38), the method comprising the acts of:

- 25 (a) positioning the draw portion of the tube (34) within a draw tube clamp (78);
- (b) positioning the return portion of the tube (34) within a return tube clamp (80);
- (c) closing the draw tube clamp (78) and the return tube clamp (80);
- (d) opening the draw tube clamp (78);
- (e) pumping blood through the draw portion of the tube (34) and into a mixing
- 30 reservoir;
- (f) opening the return tube clamp (80); and

(g) pumping blood from the mixing reservoir through the return portion of the tube (34).

5 70. The method, as set forth in claim 69, wherein act (c) comprises the acts of:
delivering a draw tube clamp signal to the draw tube clamp (78); and
delivering a return tube clamp signal to the return tube clamp (80).

10 71. The method, as set forth in claims 69 - 70, wherein act (d) comprises the act
of:
delivering a draw tube unclamp signal to the draw tube clamp (78) in response to
receiving a prime signal.

15 72. The method, as set forth in claims 69 - 71, wherein act (e) comprises the act
of:
enabling a pump in response to receiving a prime signal.

20 73. The method, as set forth in claims 69 - 72, wherein act (f) comprises the act
of:
delivering a return tube unclamp signal to the return tube clamp (80) in response to
blood in the mixing reservoir reaching a desired level.

74. The method, as set forth in claims 69 - 73, comprising:
continuing to perform acts (e) and (g) until a stop signal is received.

25 75. The method, as set forth in claim 74, comprising the act of:
generating the stop signal in response to blood flow rate through the tube (34)
dropping below a minimum blood flow rate.

30 76. The method, as set forth in claims 74 - 75, comprising the act of:
generating the stop signal in response to actuation of a stop switch.

77. The method, as set forth in claims 69 - 76, comprising the act of:

closing a vent valve (258, 260) of the mixing reservoir when the return tube clamp (80) is opened.

78. A method of operating a blood pump circuit, the circuit having a tube (34) having a draw portion for drawing blood from a patient (38) and having a return portion for returning blood to a patient (38), the method comprising the acts of:

- (a) pumping blood through the draw portion of the tube (34) and into a mixing reservoir;
- (b) mixing the blood within the mixing reservoir with a gas-enriched physiologic fluid to form gas-enriched blood;
- (c) pumping the gas-enriched blood from the mixing reservoir through the return portion of the tube (34);
- (d) generating an actual flow rate signal correlative to a rate of flow through the tube (34); and
- (e) automatically controlling the rate of flow through the tube (34) in response to the actual flow rate signal.

79. The method, as set forth in claim 78, wherein act (a) comprises the act of: maintaining a fluid level within the mixing reservoir within a desired range.

20

80. The method, as set forth in claim 78, wherein act (b) comprises the act of: mixing the blood with a gas-supersaturated physiologic fluid.

81. The method, as set forth in claim 78, wherein act (b) comprises the act of: mixing the blood with an oxygen-enriched physiologic fluid.

25

82. The method, as set forth in claim 78, wherein act (b) comprises the act of: mixing the blood with an oxygen-supersaturated physiologic fluid.

83. The method, as set forth in claims 78 - 82, comprising: continuing to perform acts (a), (b), and (c) until a stop signal is received.

30

84. The method, as set forth in claim 83, comprising the act of:
generating the stop signal in response to the flow rate through the tube (34)
dropping below a minimum flow rate.
- 5 85. The method, as set forth in claim 83, comprising the act of:
generating the stop signal in response to actuation of a stop switch.
86. The method, as set forth in claims 78 - 85, wherein act (d) comprises the act
of:
10 operatively coupling a flow transducer to the tube (34), the flow transducer
generating the actual flow rate signal; and
delivering the actual flow rate signal to a flow meter (46).
87. The method, as set forth in claims 78 - 86, wherein act (e) comprises the act
15 of:
generating a desired flow rate signal correlative to a desired flow rate through the
tube (34); and
automatically adjusting the actual rate of flow through the tube (34) to the desired
flow rate in response to the desired flow rate signal and the actual flow rate signal.
- 20 88. A method of operating a blood pump circuit, the circuit having a tube (34)
having a draw portion for drawing blood from a patient (38) and having a return portion for
returning blood to a patient (38), the method comprising the acts of:
(a) pumping blood through the draw portion of the tube (34) and into a mixing
25 reservoir;
(b) mixing the blood within the mixing chamber (64) with a gas-enriched
physiologic fluid to form gas-enriched blood;
(c) pumping the gas-enriched blood from the mixing reservoir through the
return portion of the tube (34);
30 (d) generating a desired flow rate signal correlative to a desired rate of flow
through the tube (34);

(e) generating an actual flow rate signal correlative to an actual rate of flow through the tube (34); and

(f) automatically adjusting the actual rate of flow through the tube (34) to the desired flow rate in response to the desired flow rate signal and the actual flow rate signal.

5

89. The method, as set forth in claim 88, wherein act (a) comprises the act of: maintaining a fluid level within the mixing reservoir within a desired range.

90. The method, as set forth in claims 88 - 89, wherein act (b) comprises the act
10 of:

mixing the blood with the gas-enriched physiologic fluid which comprises a gas-supersaturated physiologic fluid.

91. The method, as set forth in claims 88 - 89, wherein act (b) comprises the act
15 of:

mixing the blood with the gas-enriched physiologic fluid which comprises an oxygen-enriched physiologic fluid.

92. The method, as set forth in claims 88 - 89, wherein act (b) comprises the act
20 of:

mixing the blood with the gas-enriched physiologic fluid which comprises an oxygen-supersaturated physiologic fluid.

93. The method, as set forth in claims 88 - 92, comprising:
25 continuing to perform acts (a), (b), and (c) until a stop signal is received.

94. The method, as set forth in claim 93, comprising the act of:
generating the stop signal in response to the flow rate through the tube (34)
dropping below a minimum flow rate.

30

95. The method, as set forth in claim 93, comprising the act of:
generating the stop signal in response to actuation of a stop switch.

96. The method, as set forth in claims 88 - 95, wherein act (d) comprises the act of:

5 actuating a user-actuatable input operatively coupled to a display (32) to adjust the desired flow rate illustrated by the display (32).

97. The method, as set forth in claims 88 - 96, wherein act (d) comprises the act of:

10 storing the desired rate of flow in a memory of a personality module, the personality module generating the desired flow rate signal.

98. The method, as set forth in claim 97, wherein the desired flow rate stored in the personality module comprises a desired range of flow rates.

15 99. The method, as set forth in claims 88 - 98, wherein act (e) comprises the act of:

operatively coupling a flow transducer to the tube (34), the flow transducer generating the actual flow rate signal; and

20 delivering the actual flow rate signal to a flow meter (46).

25

30

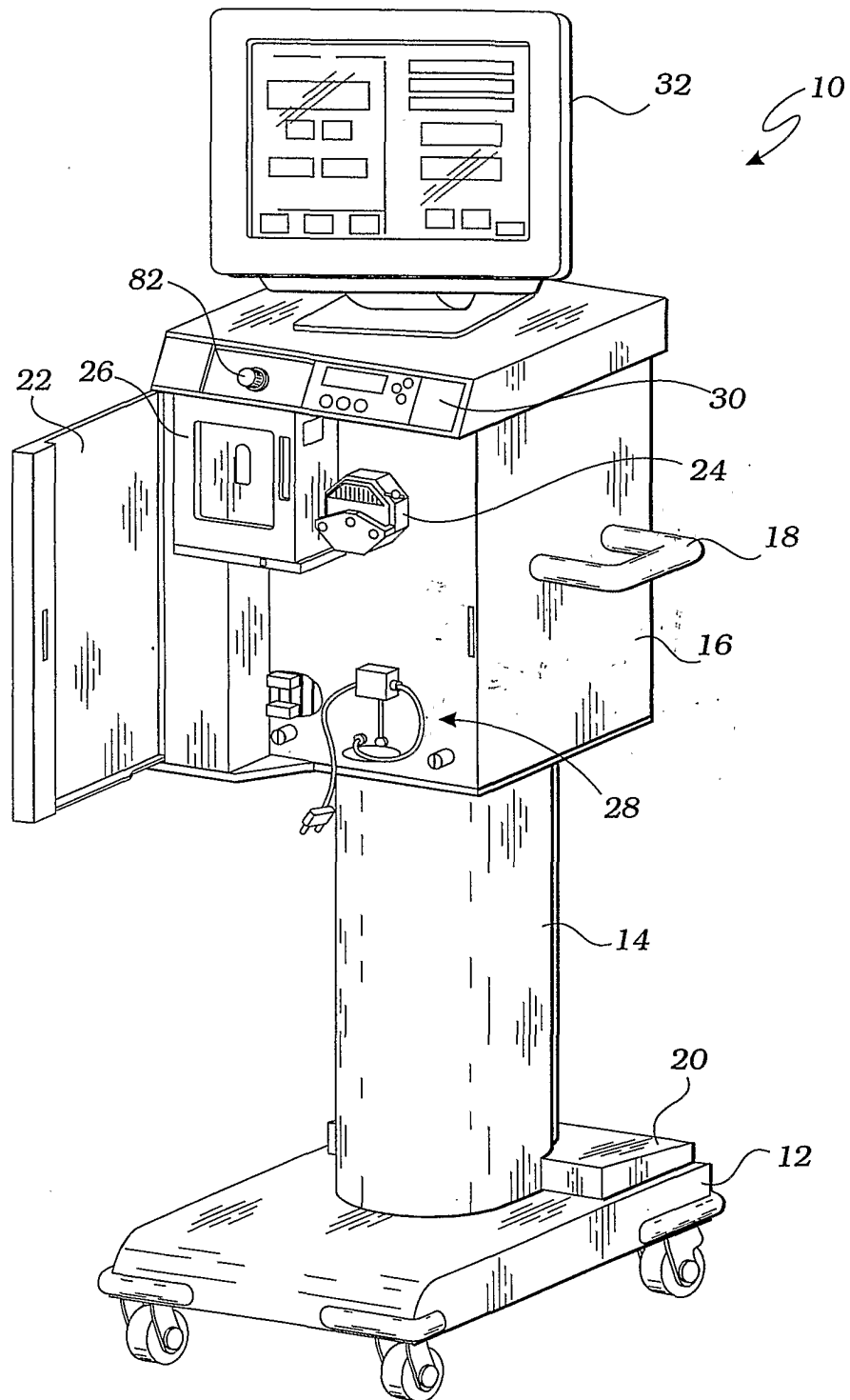

Fig. 1

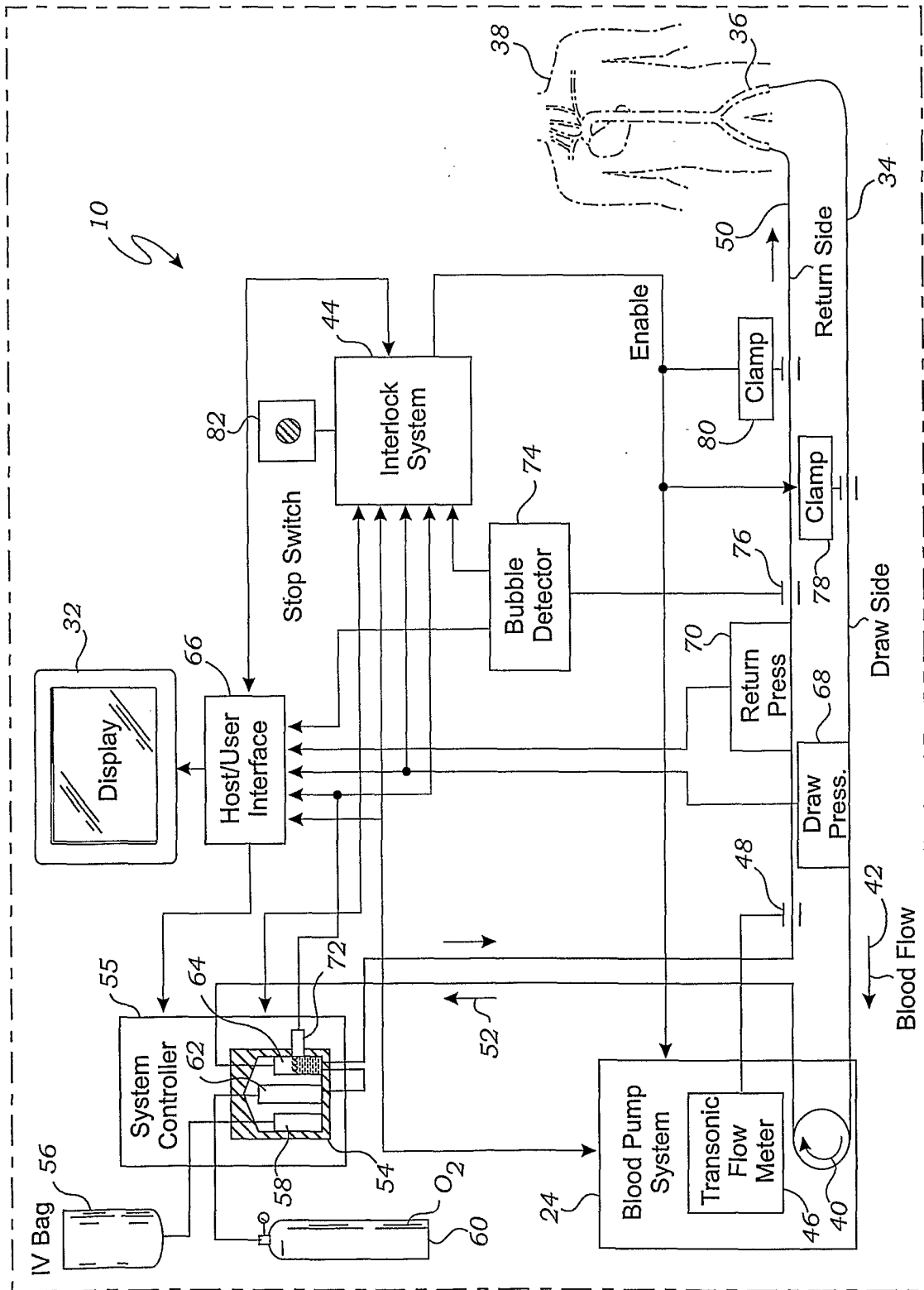

Fig. 2

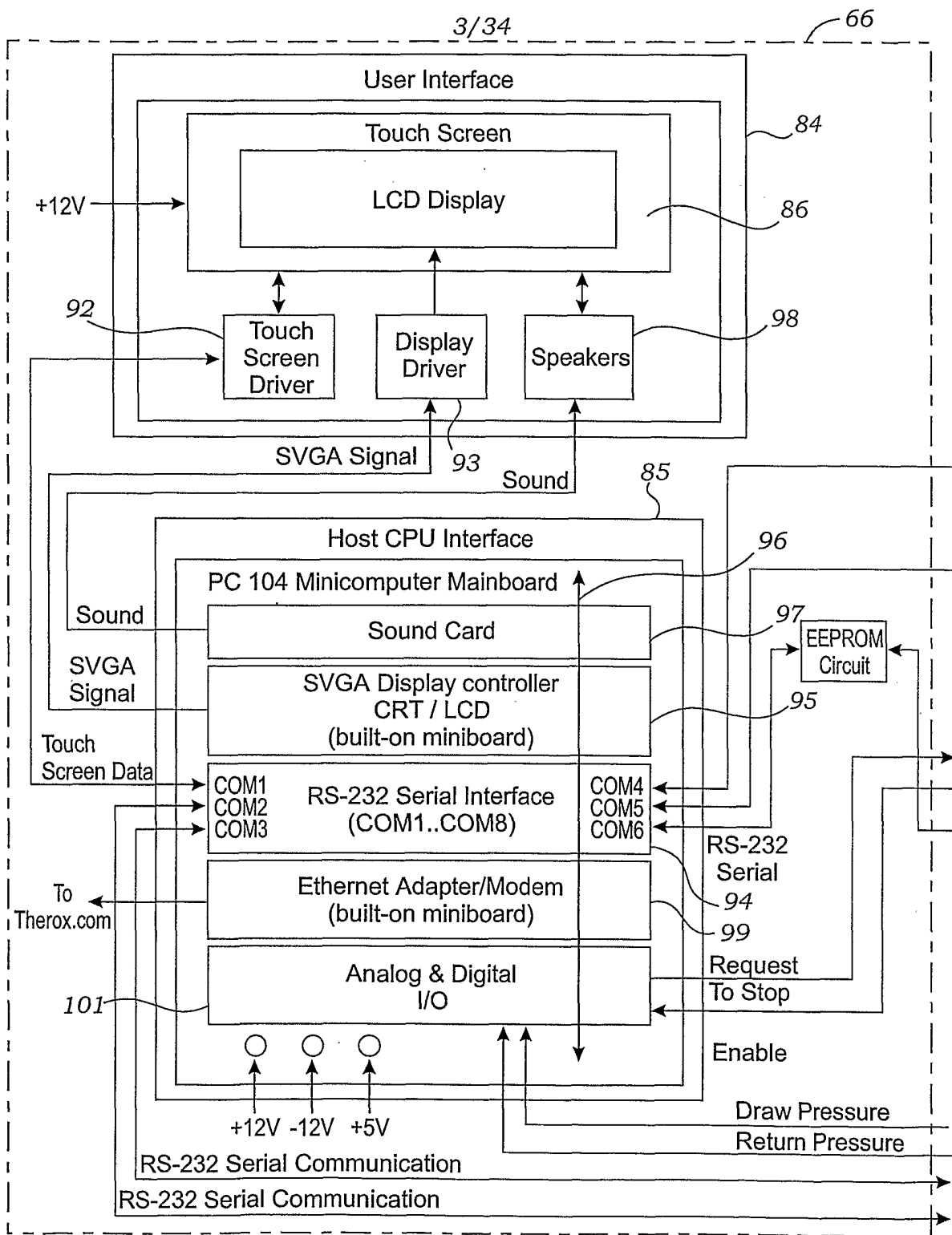

Fig. 3

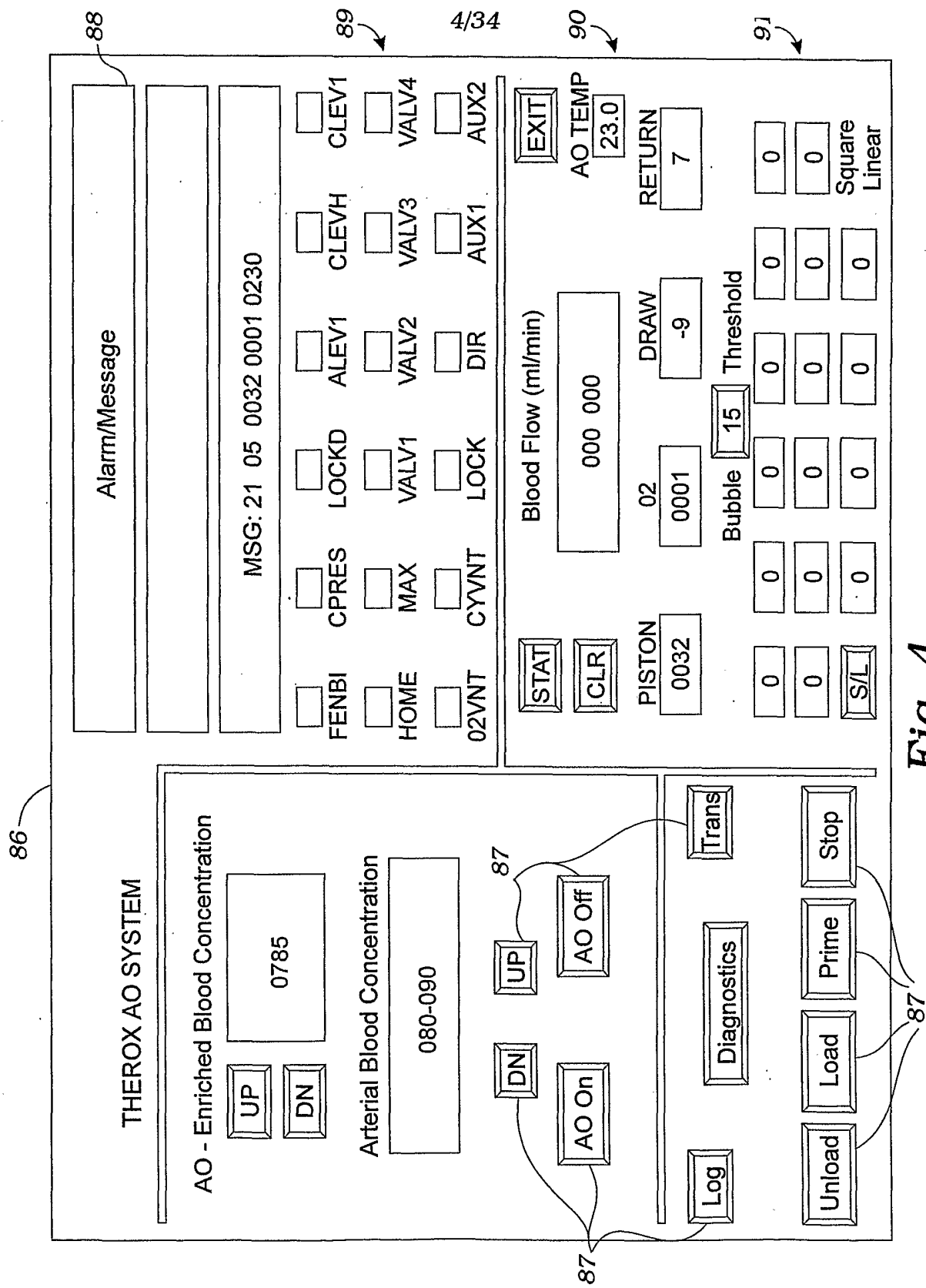

Fig. 4

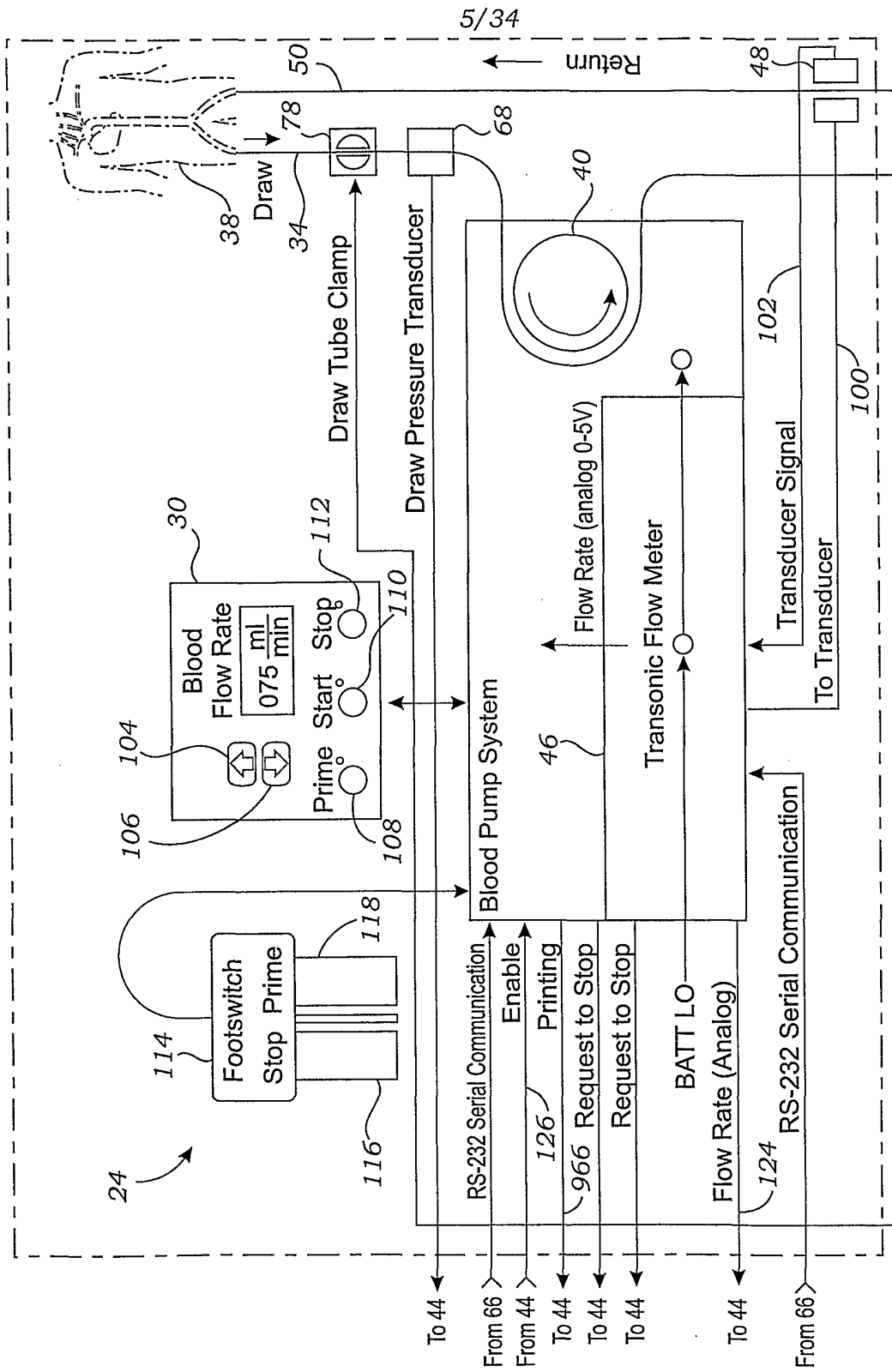

Fig. 5

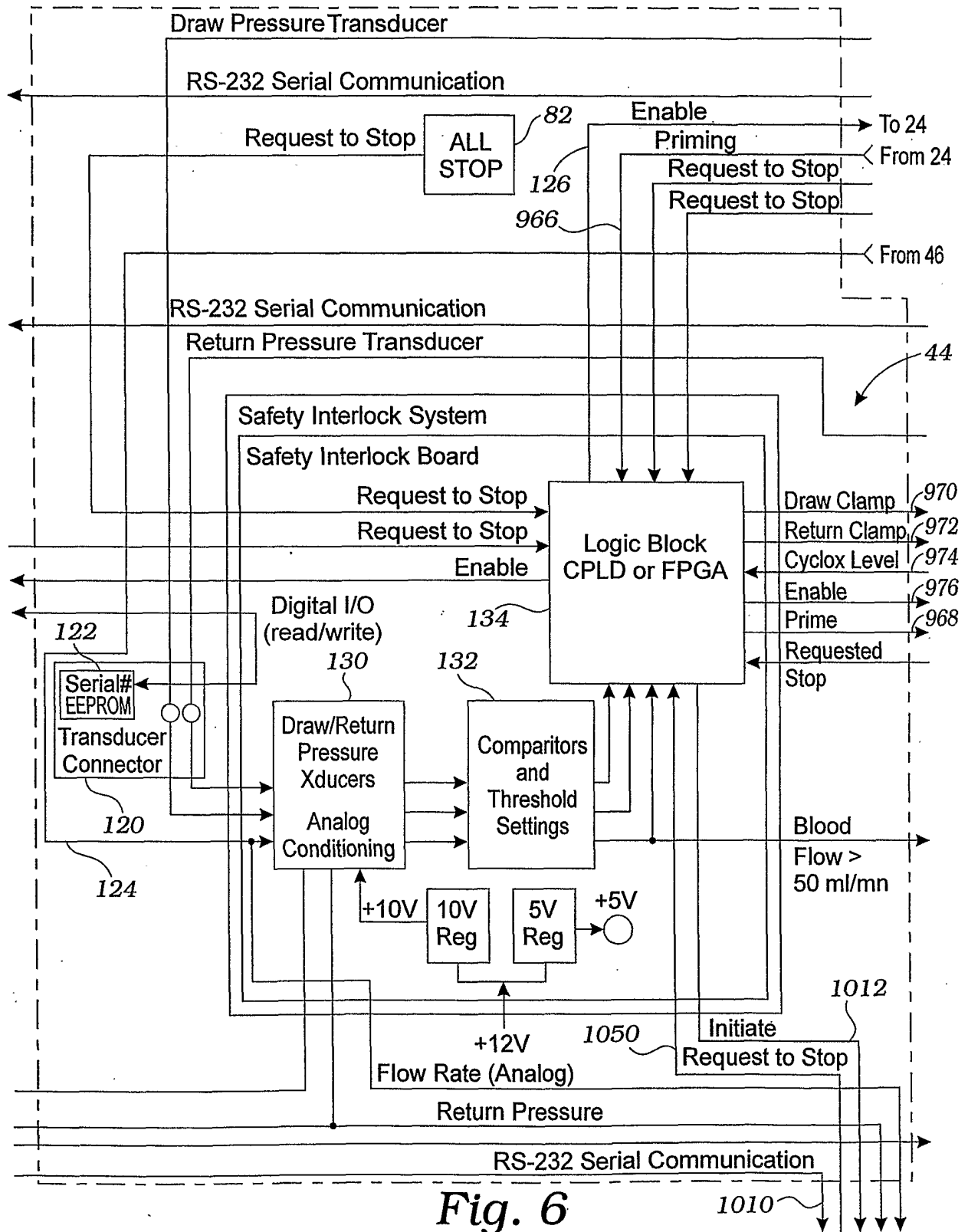

Fig. 6

7/34

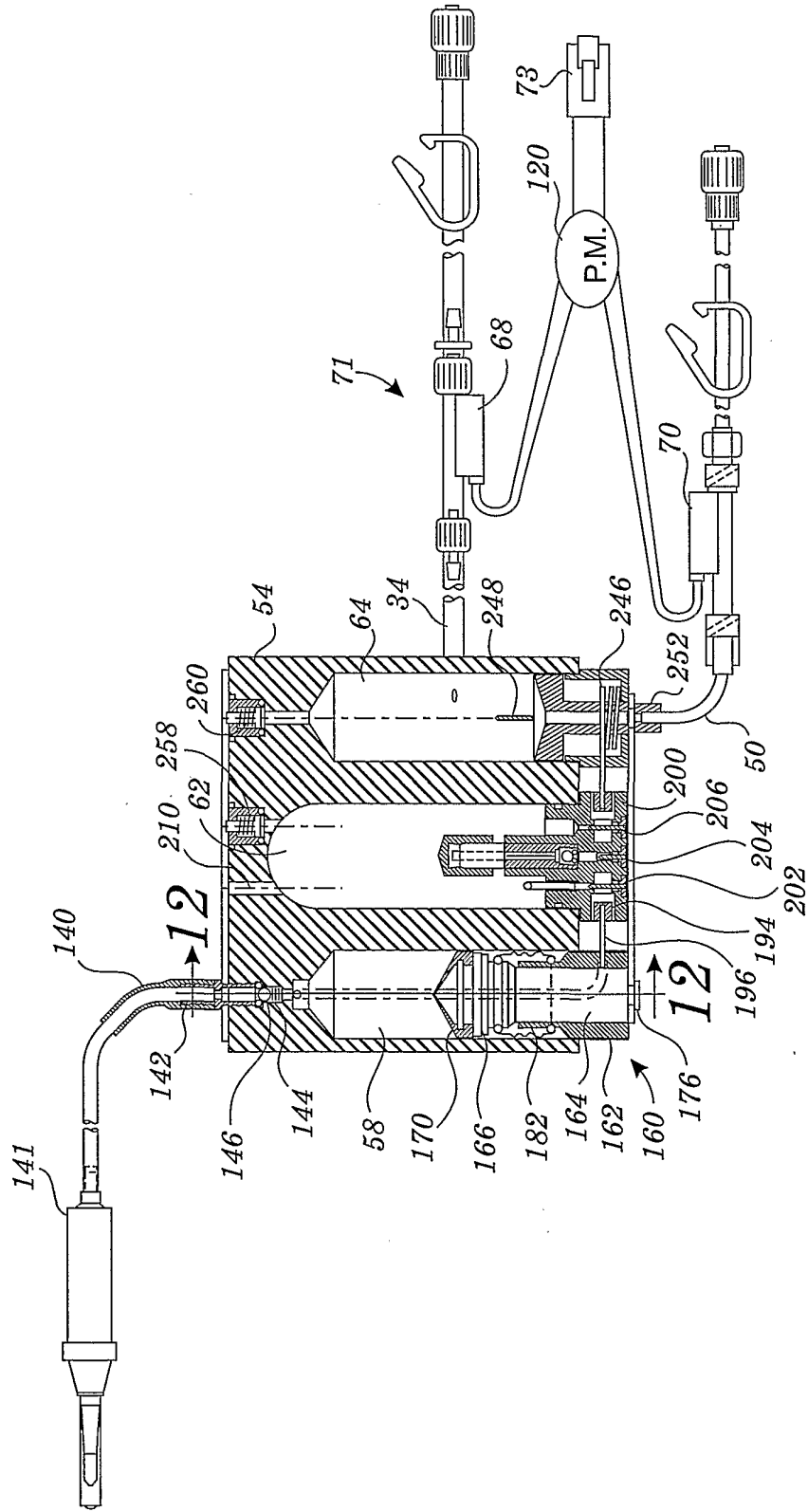

Fig. 8

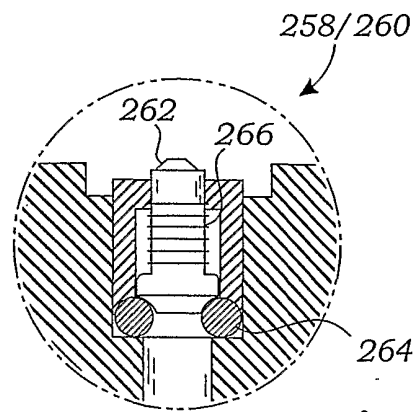
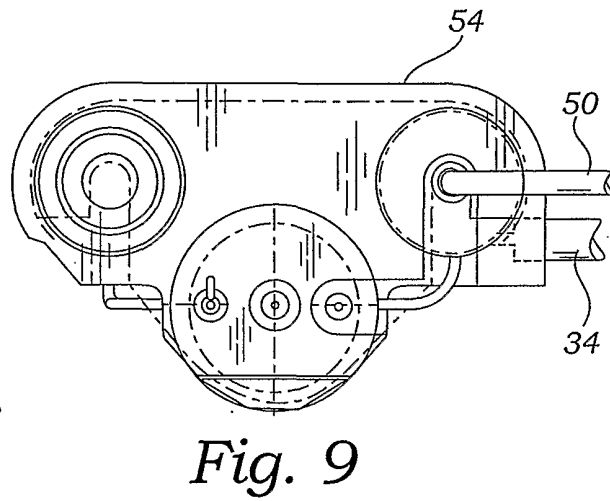
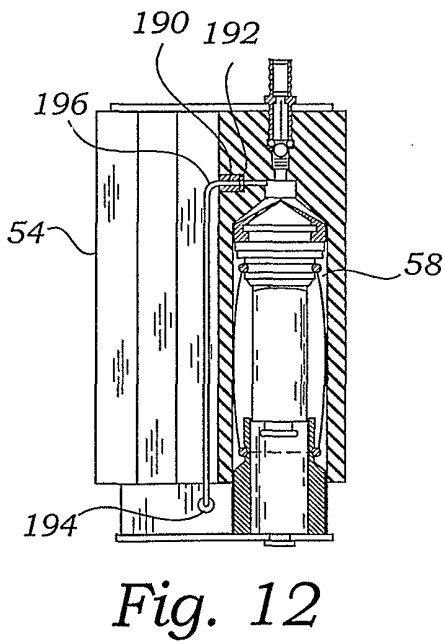
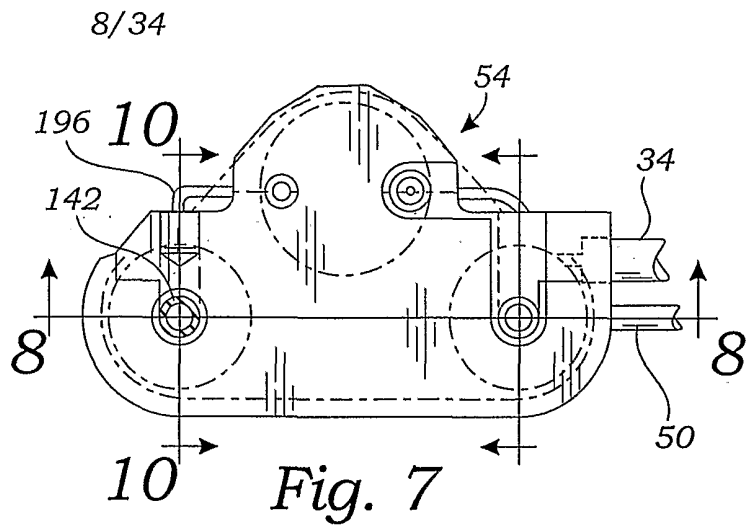
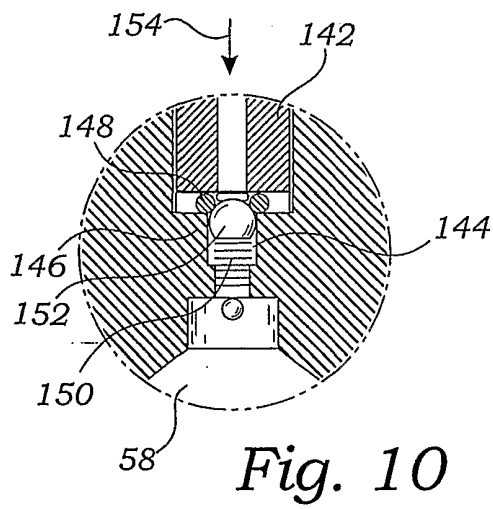

Fig. 16

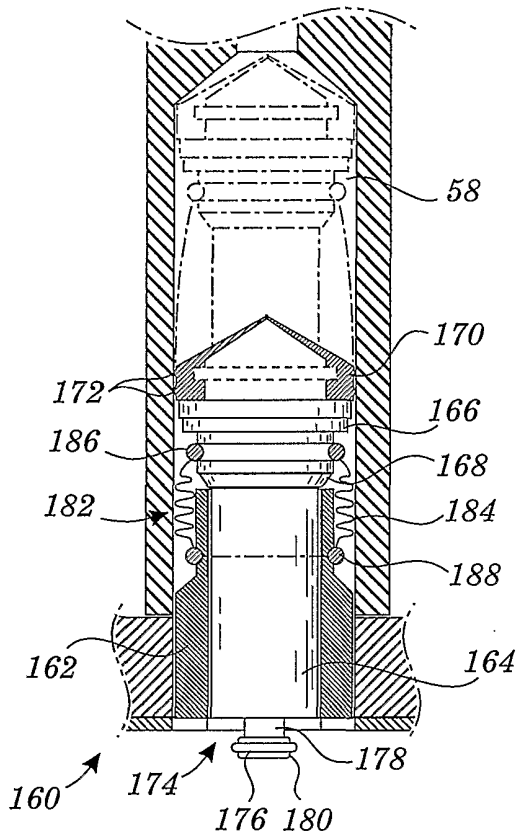

Fig. 11

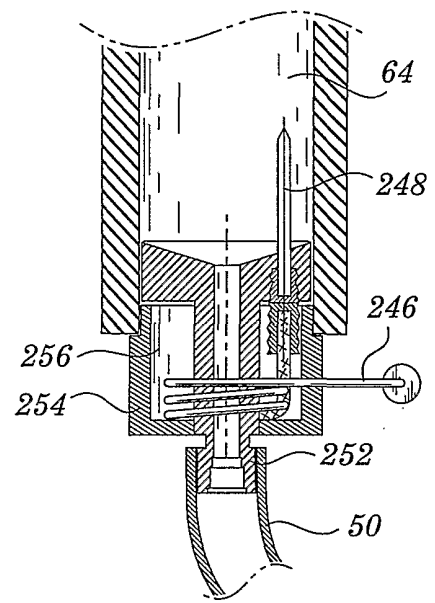

Fig. 15

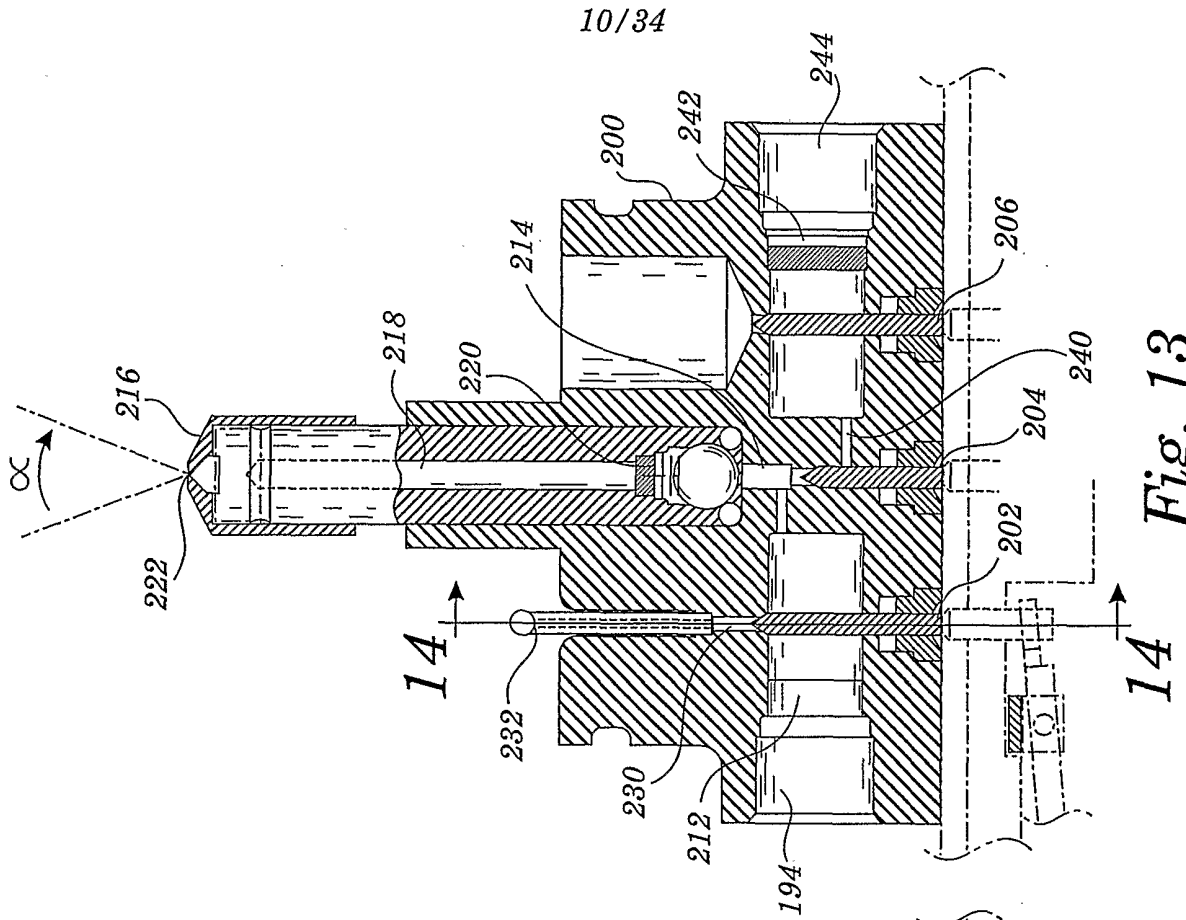

Fig. 13

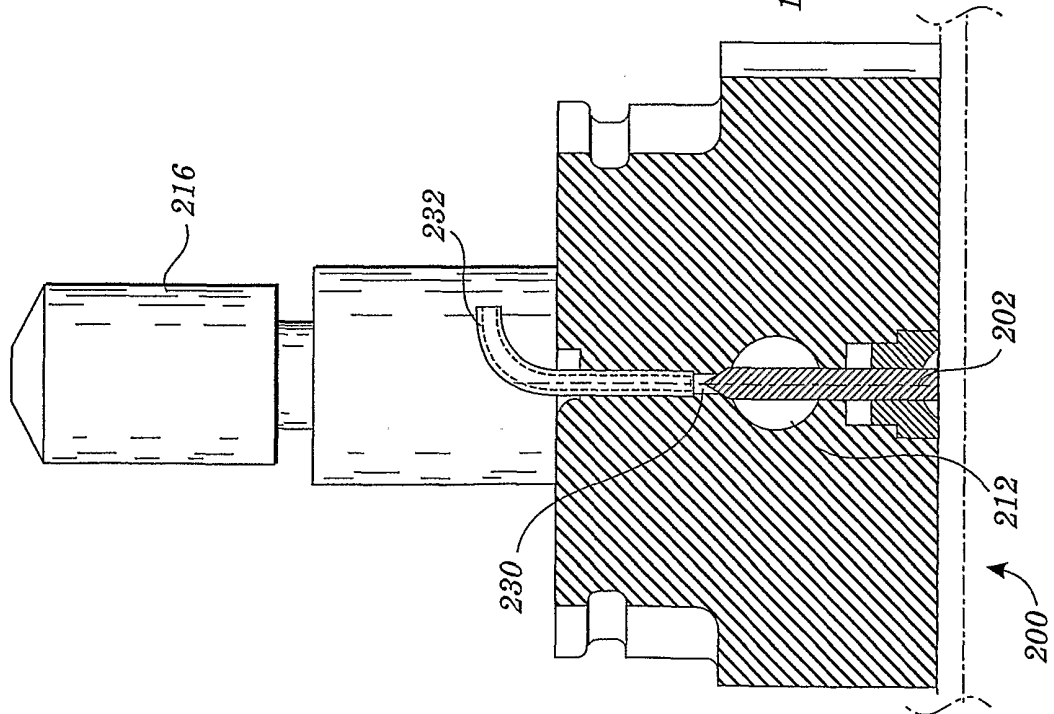

Fig. 14

11/34

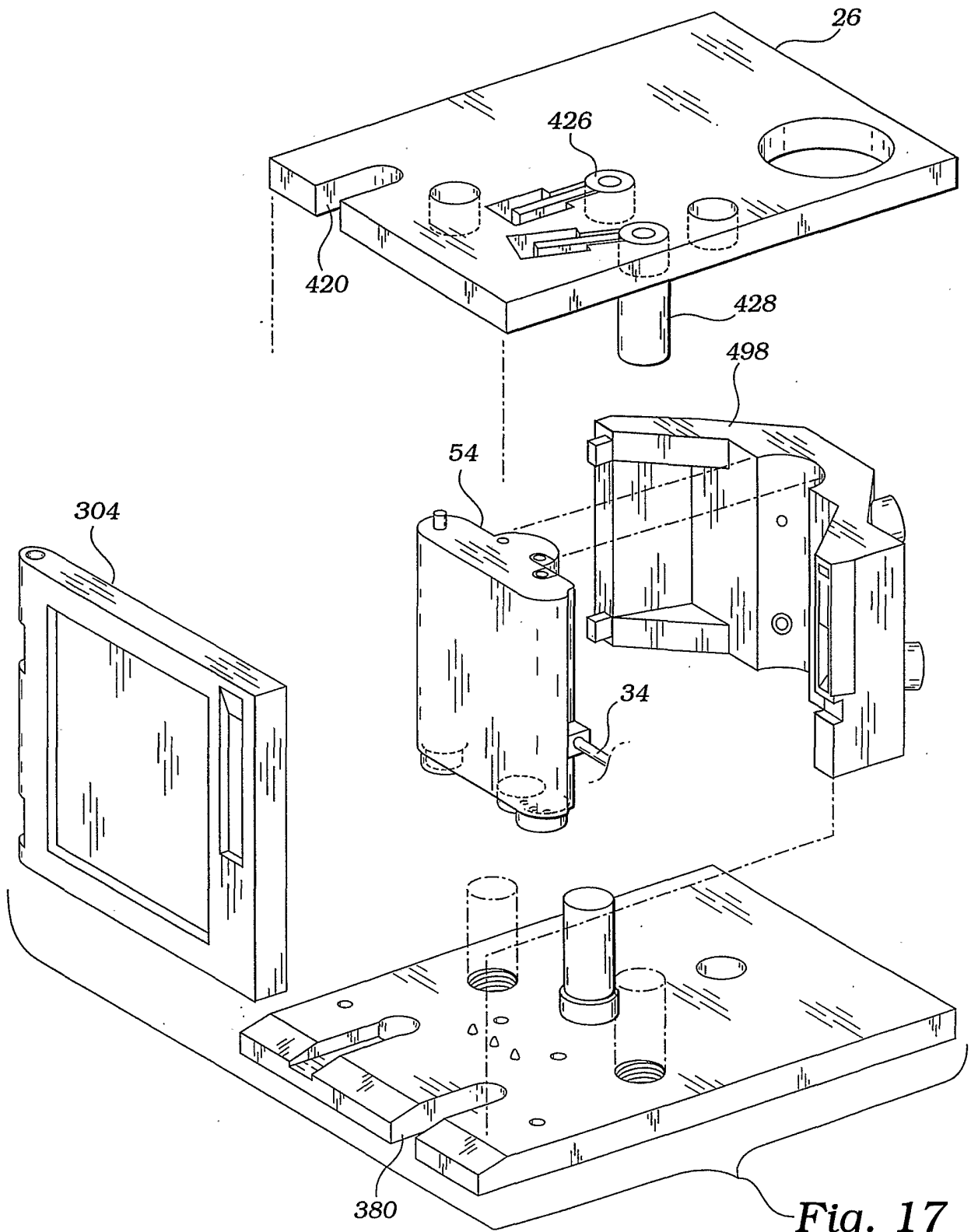

Fig. 17

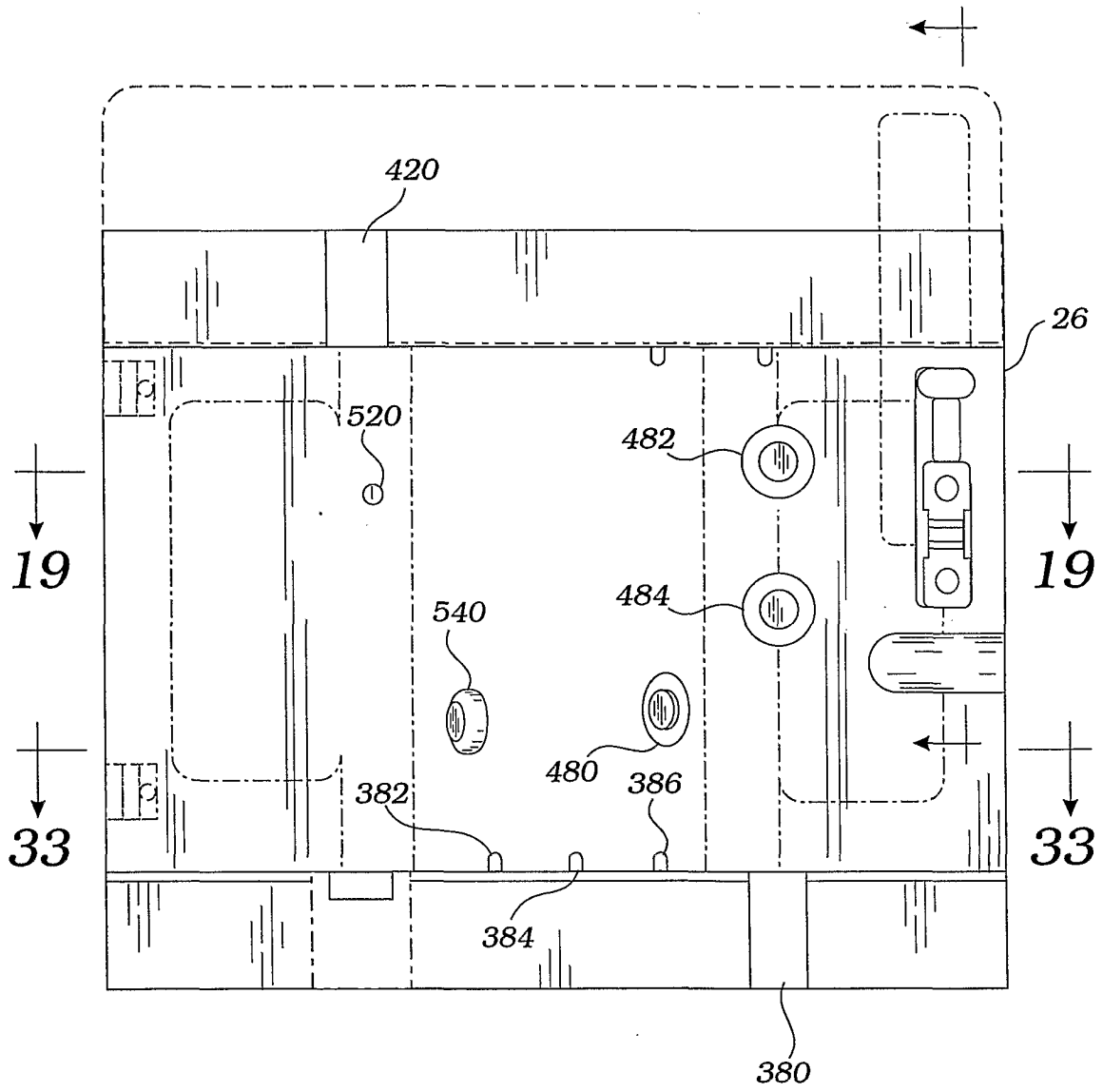

Fig. 18

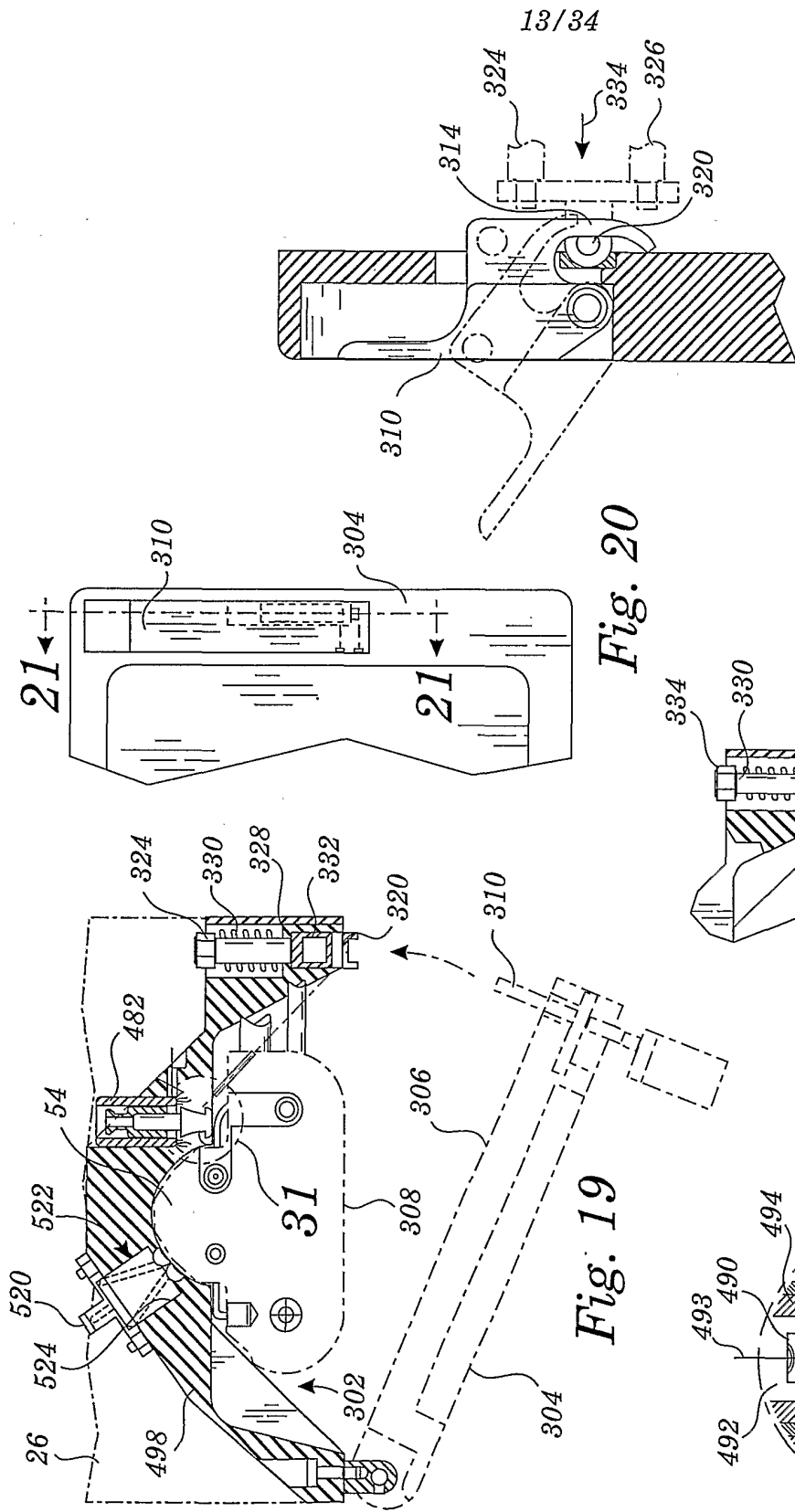

Fig. 20

Fig. 21

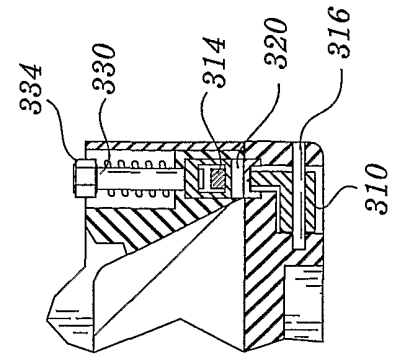

Fig. 23

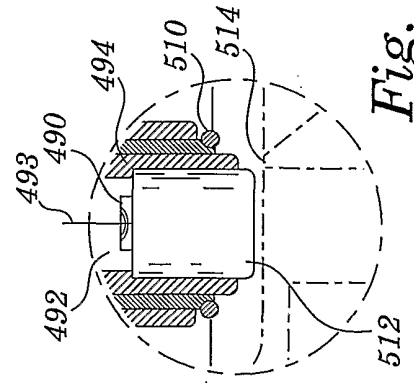

Fig. 34

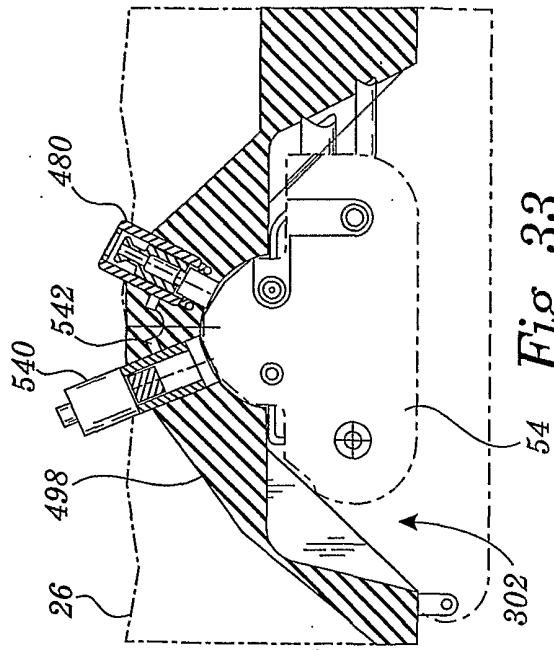

Fig. 33

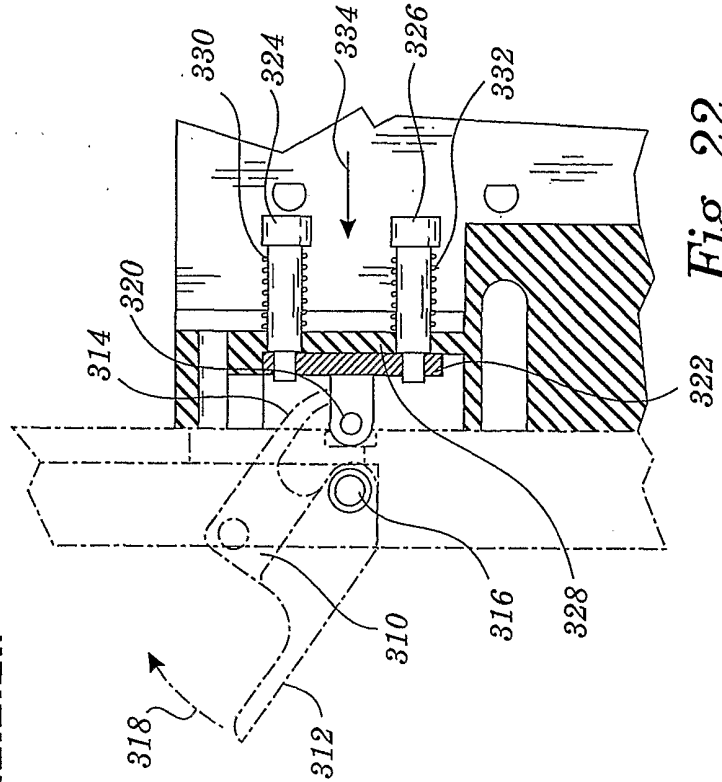

Fig. 22

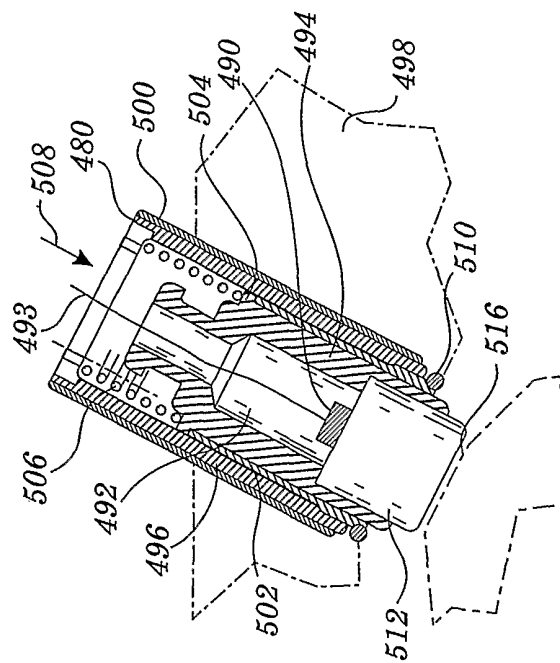

Fig. 35

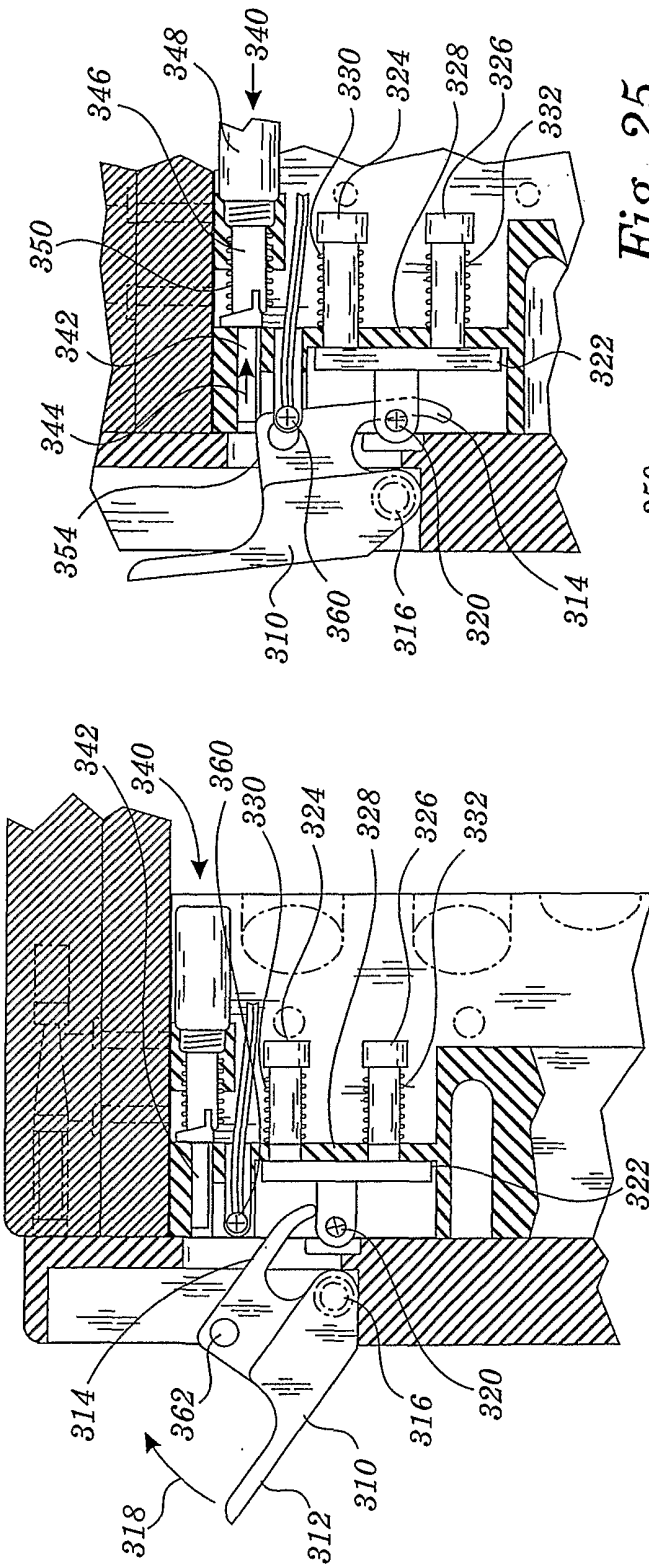

Fig. 24

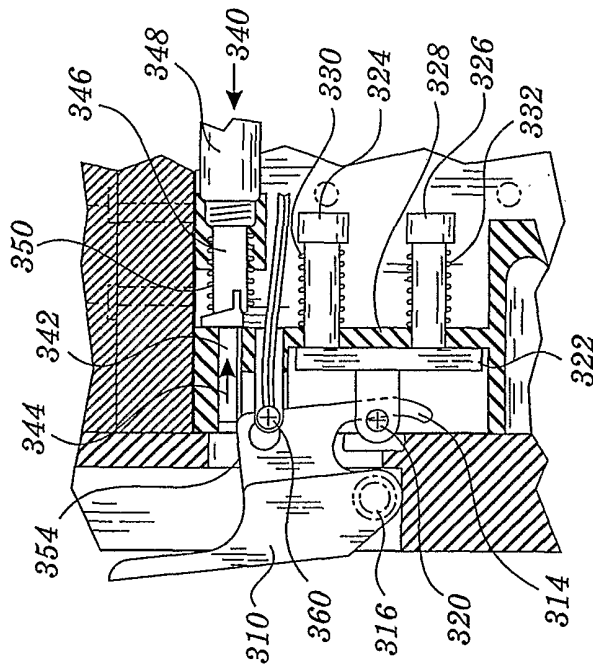

Fig. 25

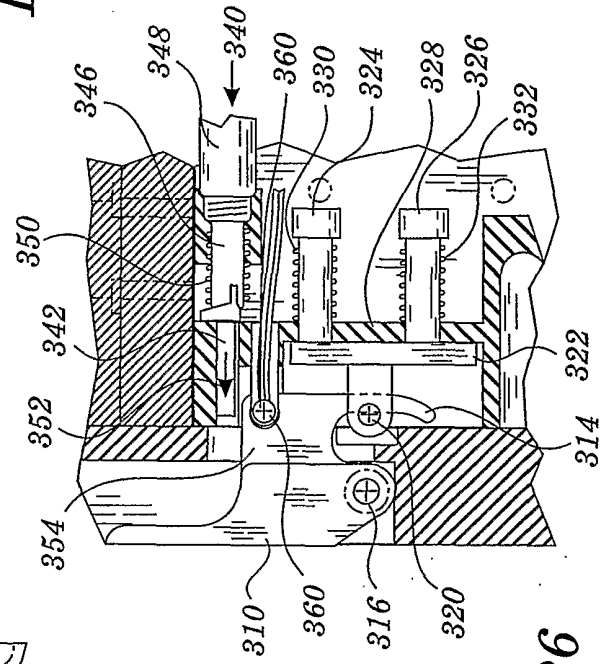

Fig. 26

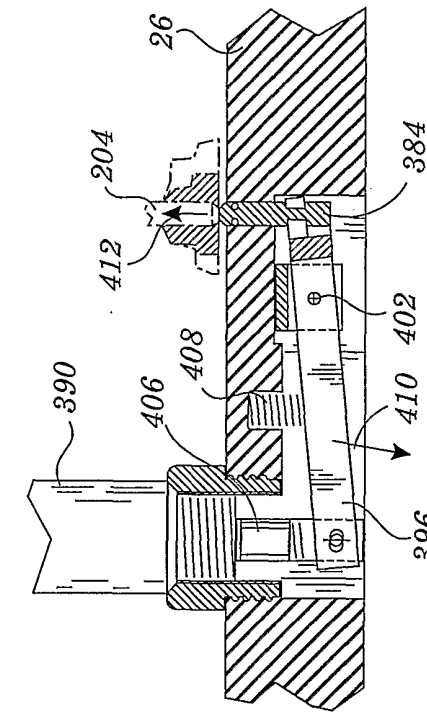

Fig. 28

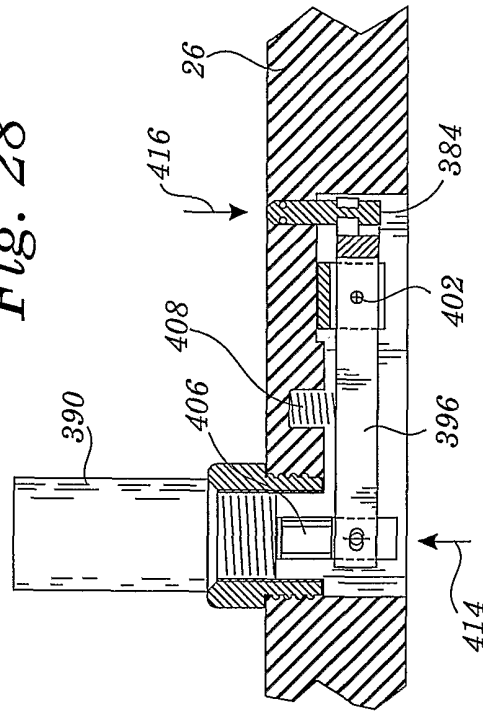

Fig. 29

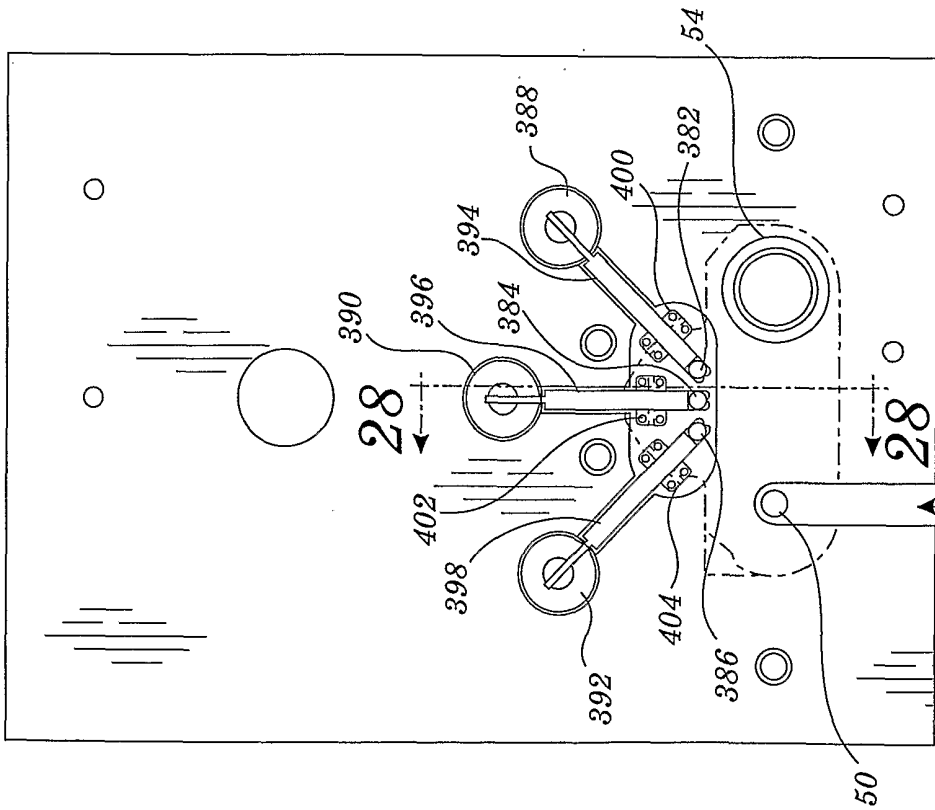

Fig. 27

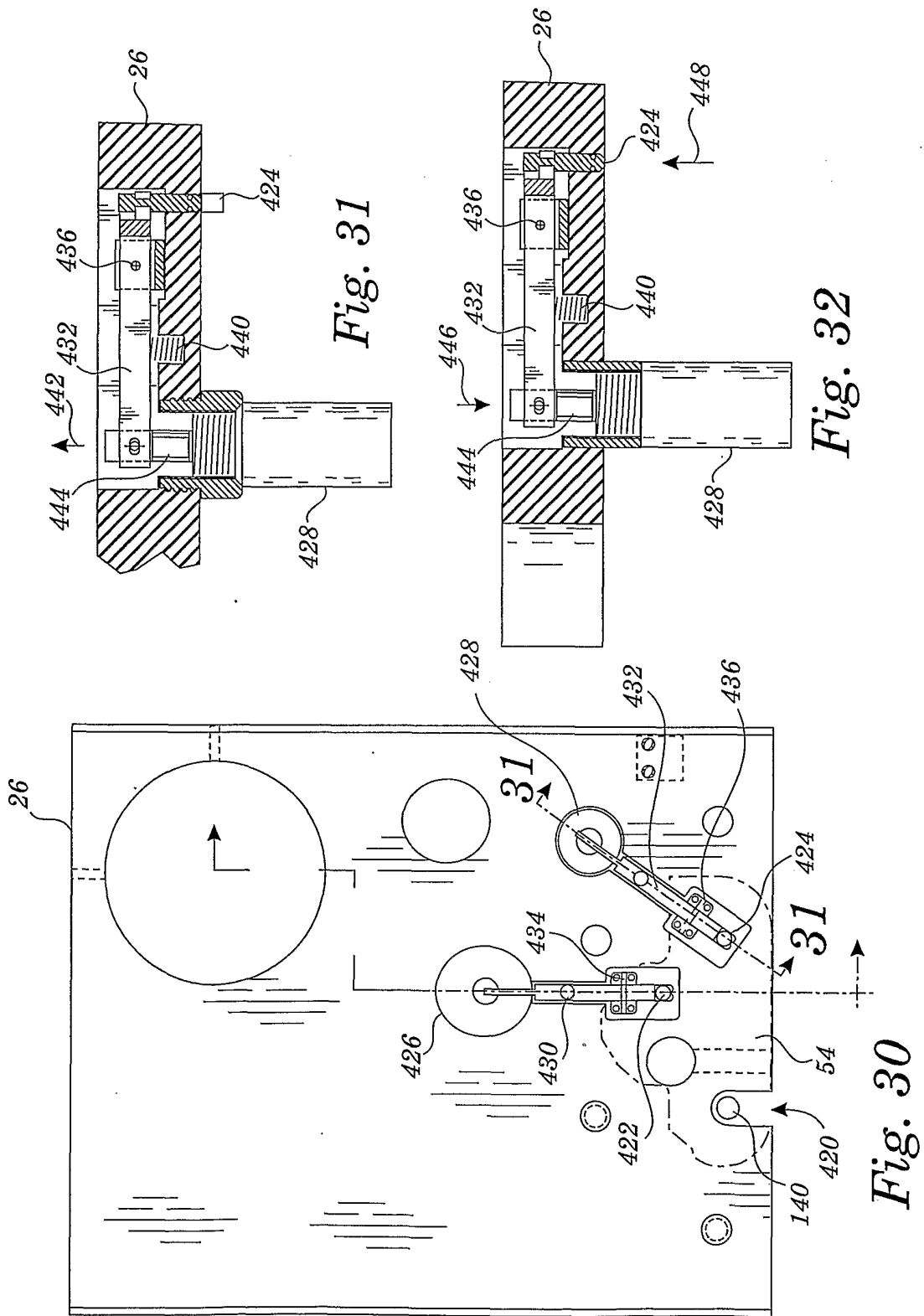

Fig. 31

Fig. 32

Fig. 30

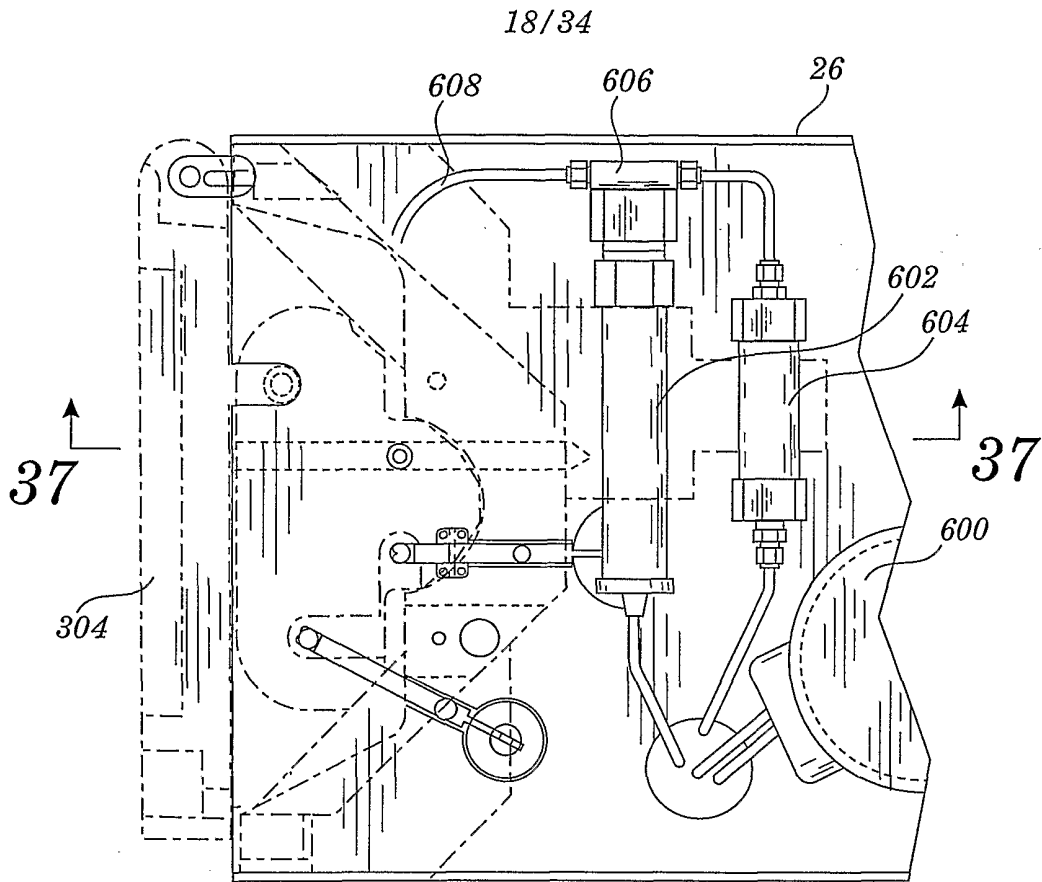

Fig. 36

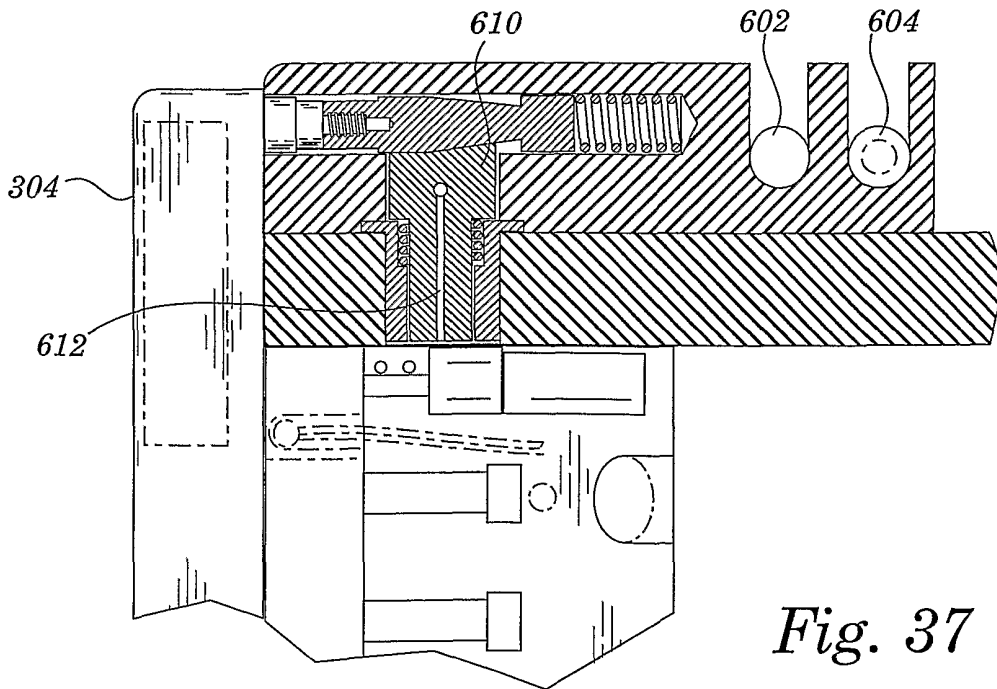

Fig. 37

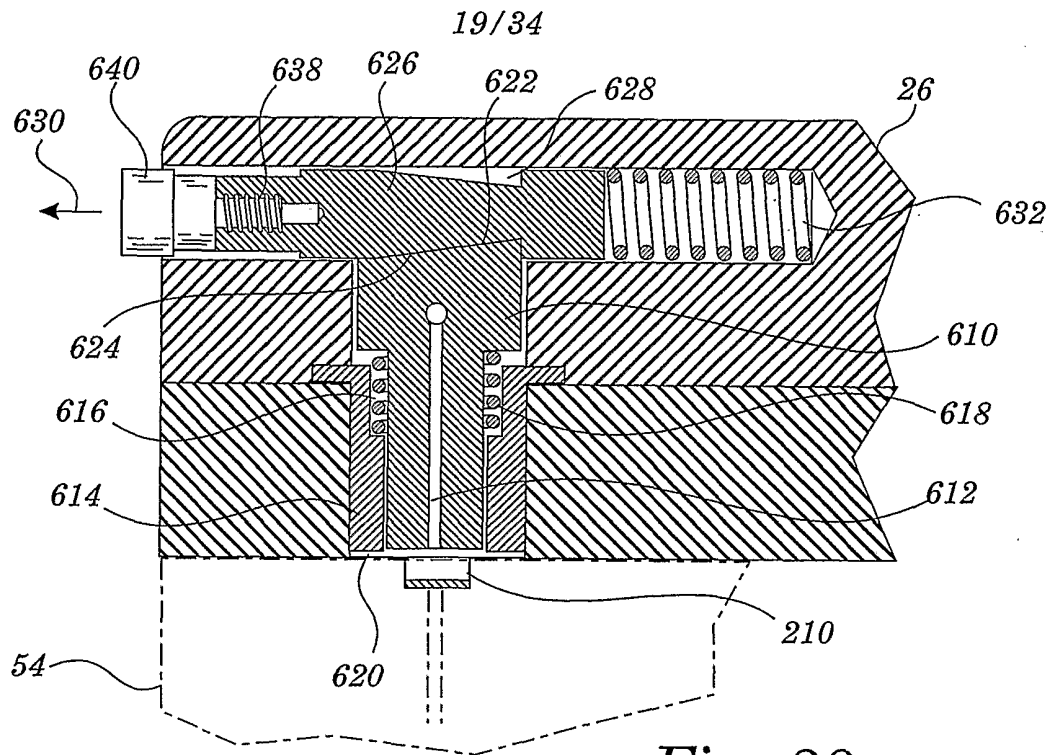

Fig. 38

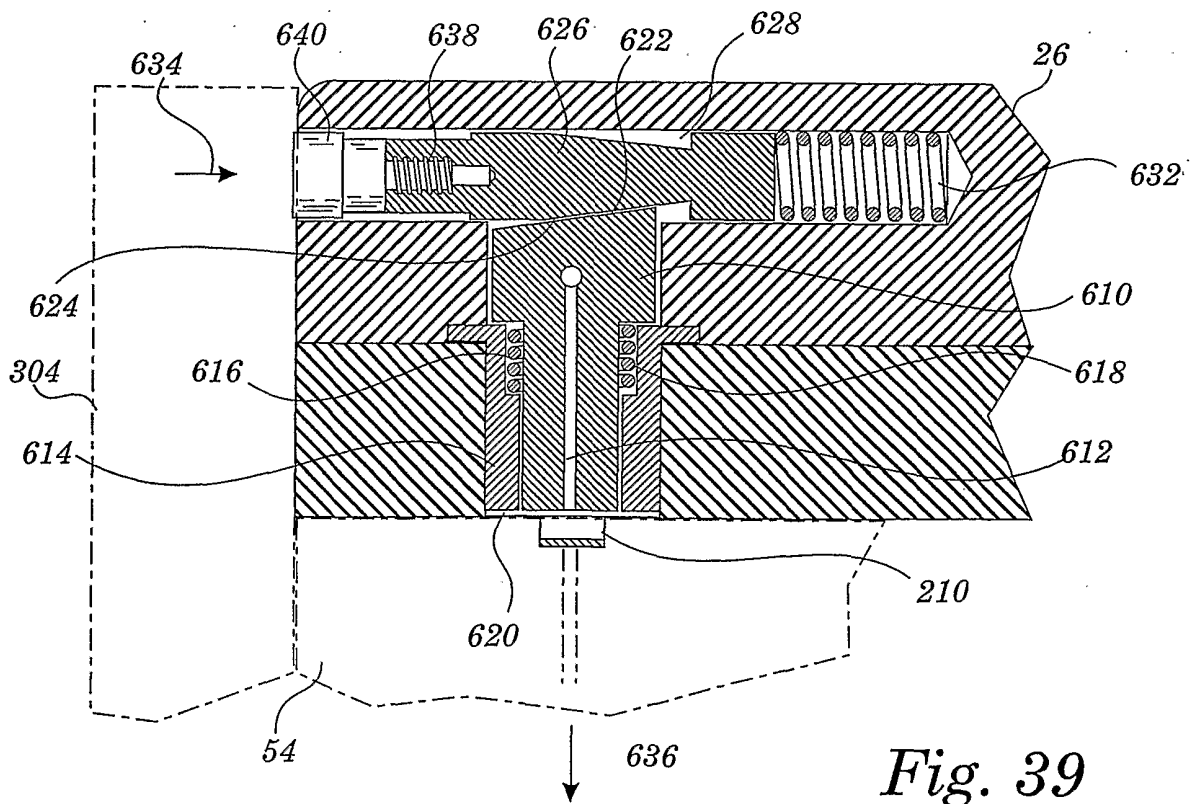

Fig. 39

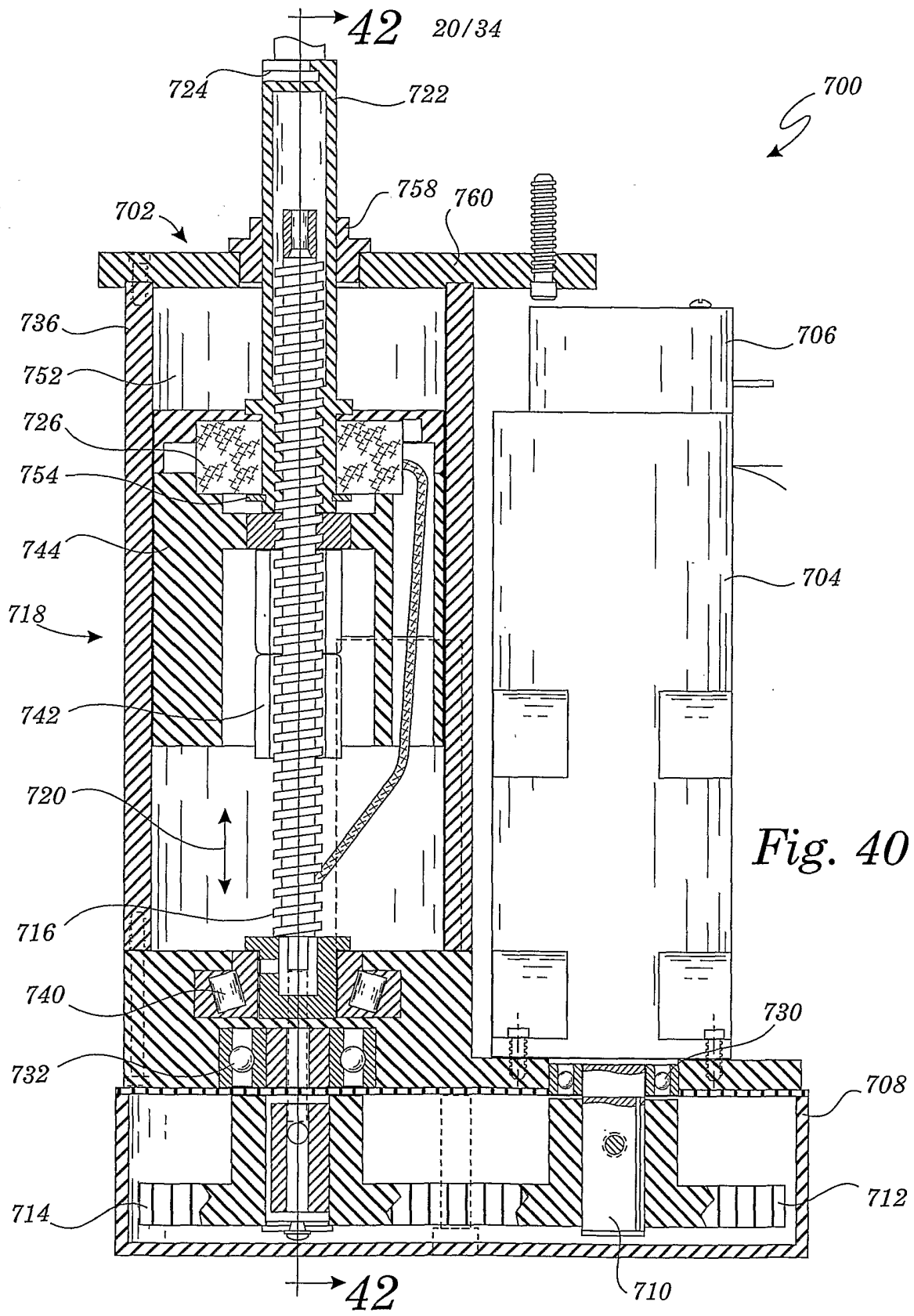
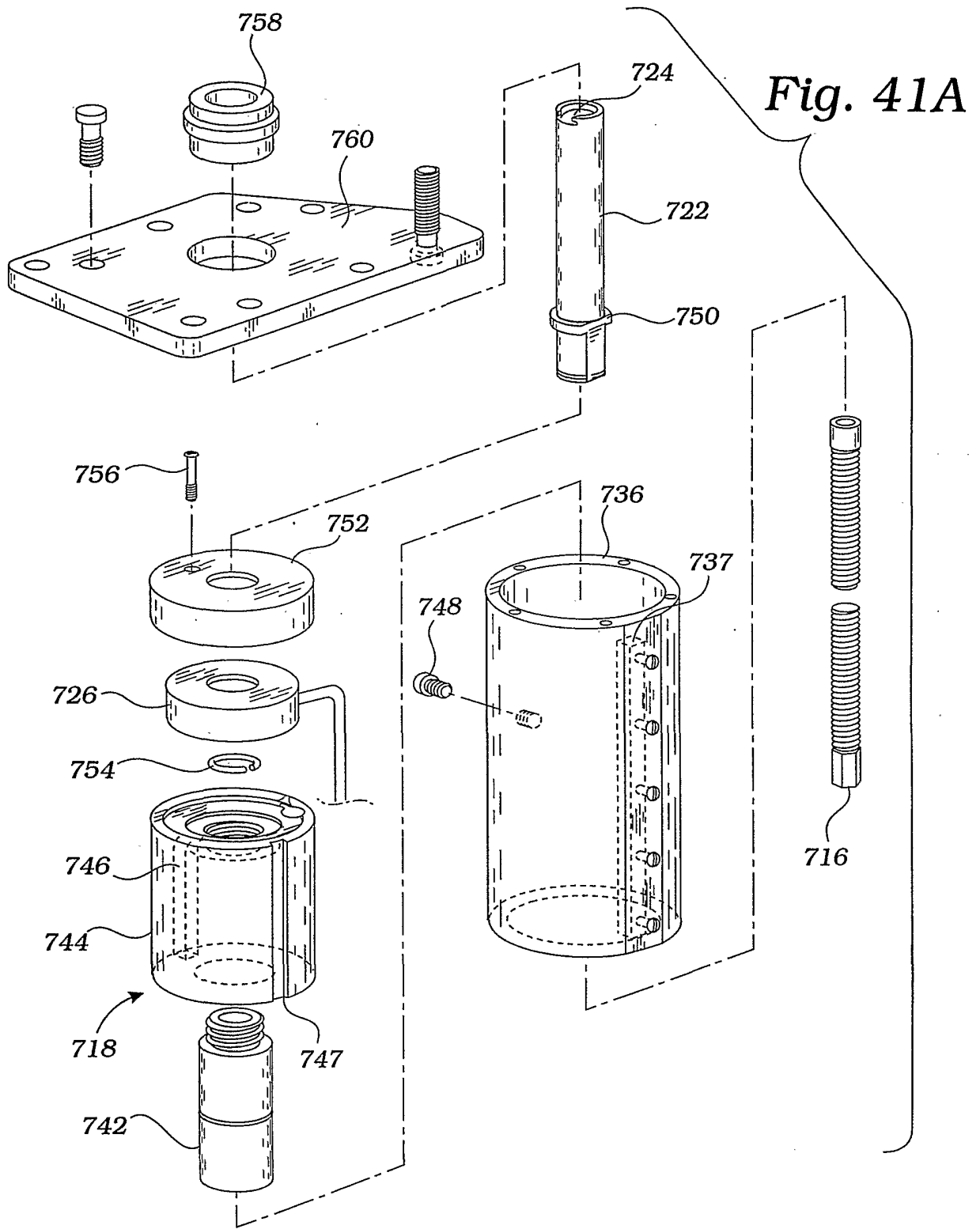

Fig. 40



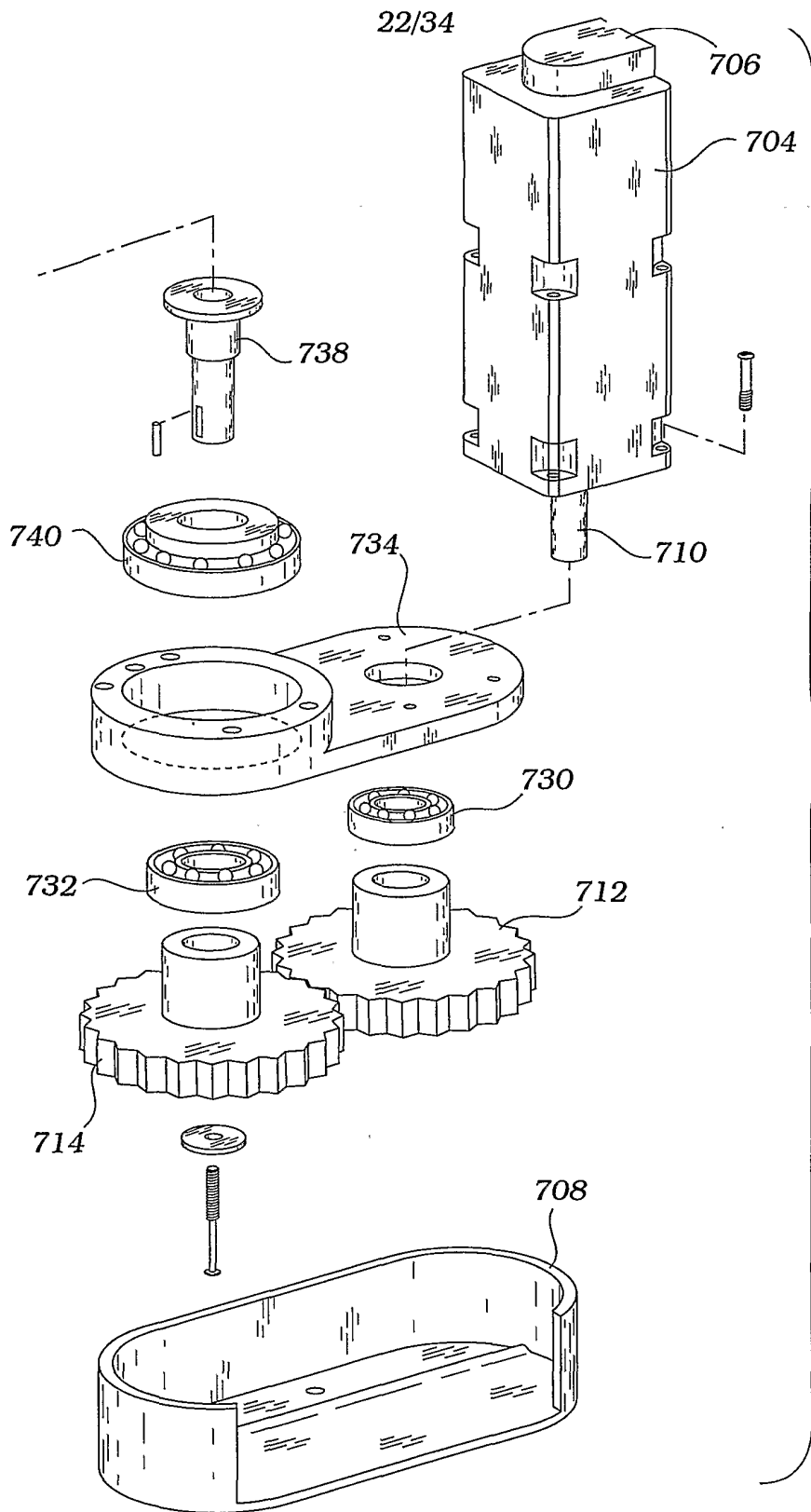

Fig. 41B

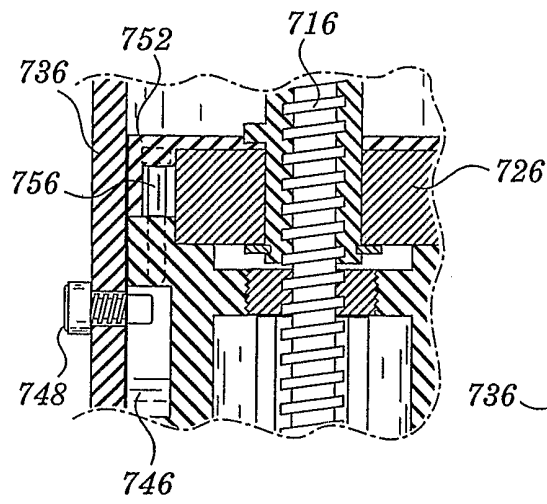

Fig. 43

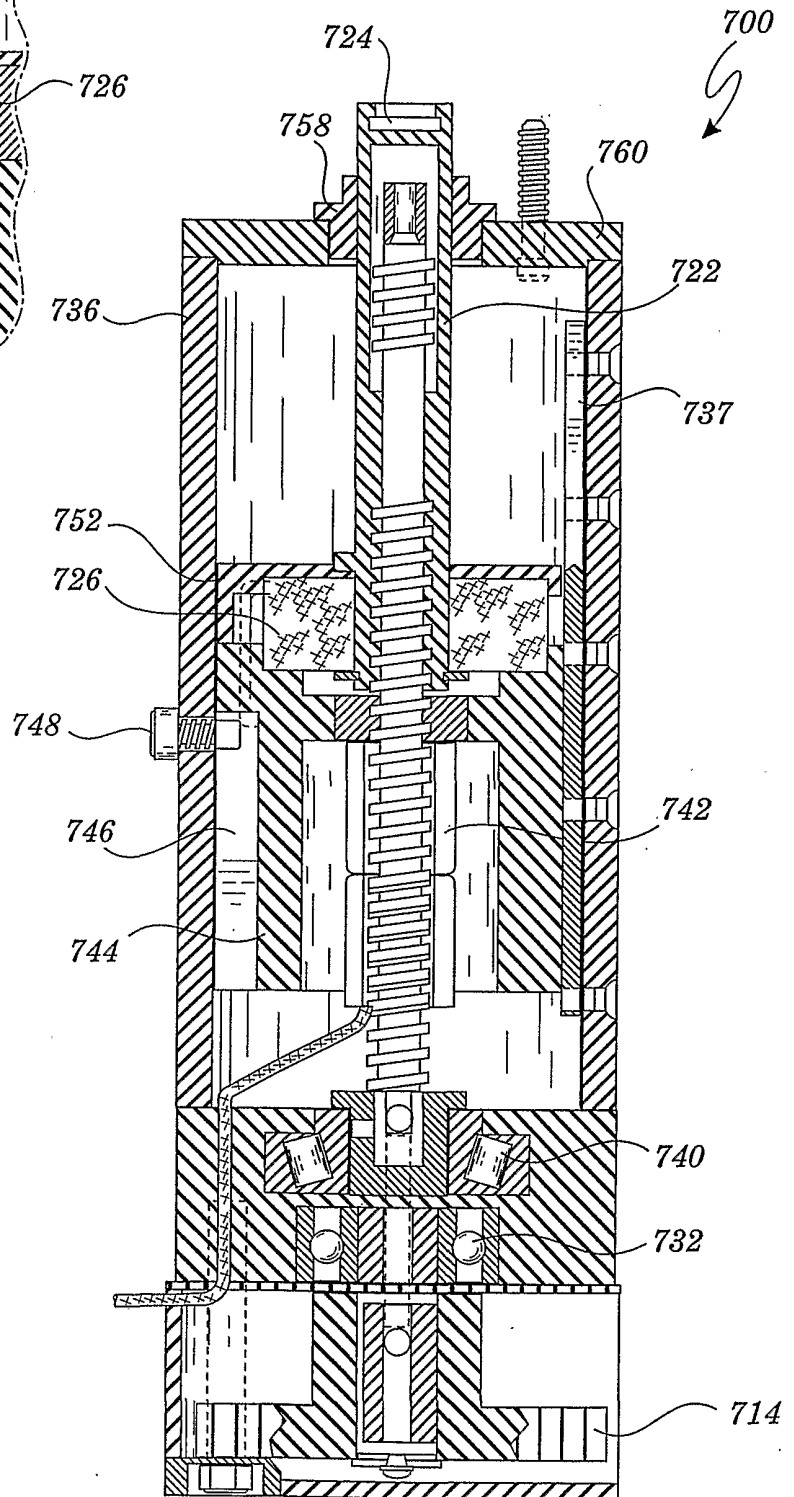

Fig. 42

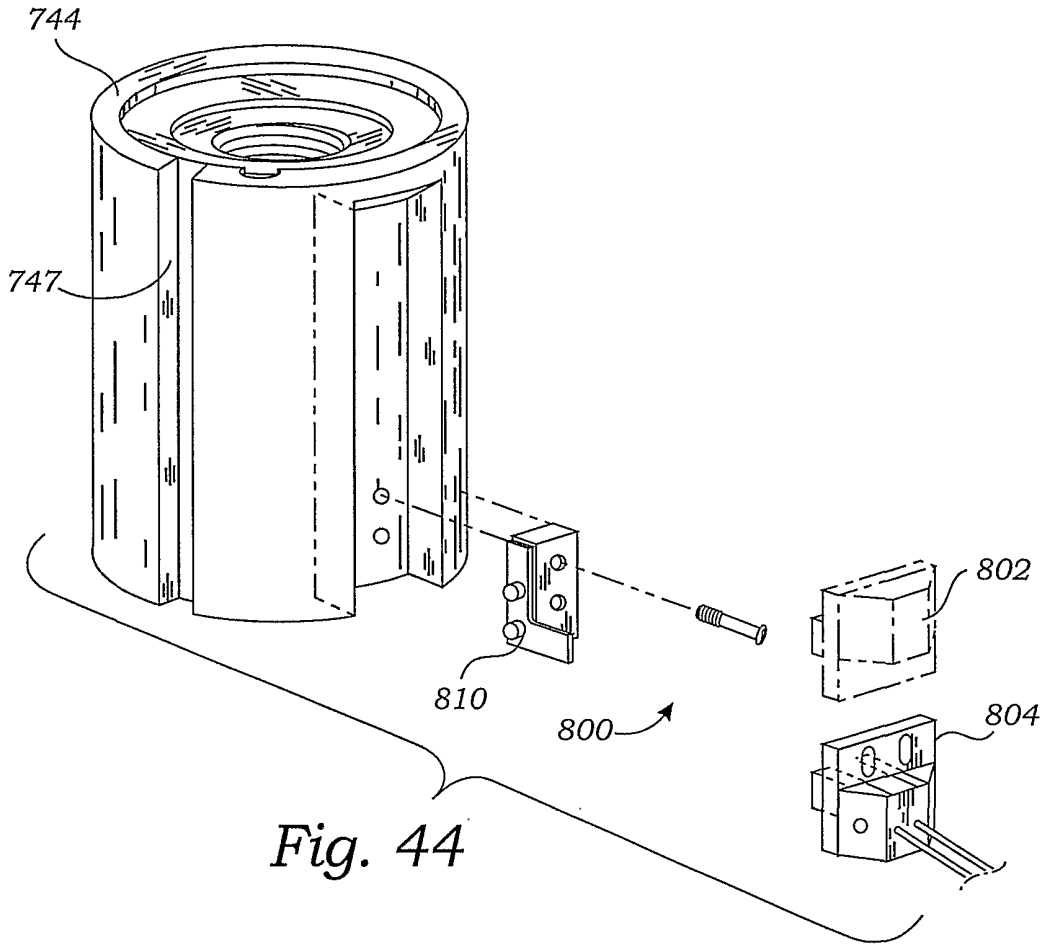

Fig. 44

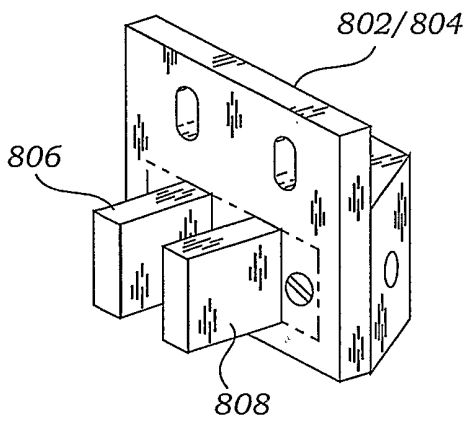

Fig. 48

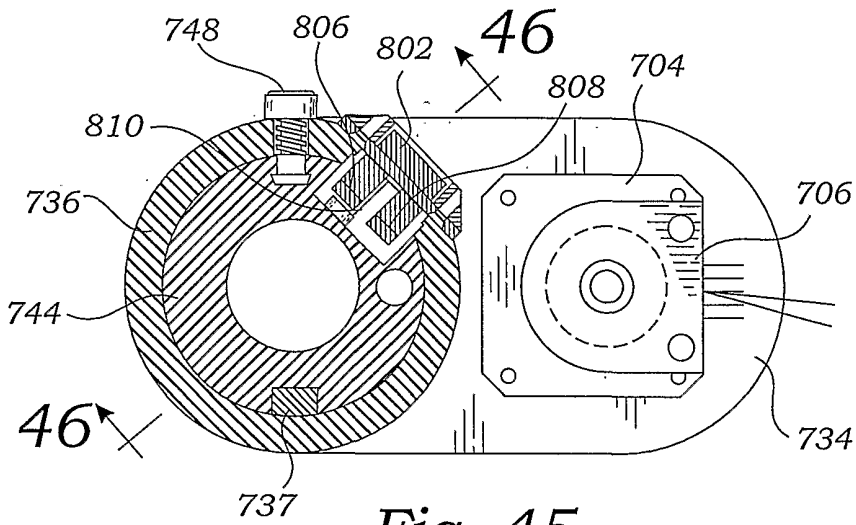

Fig. 45

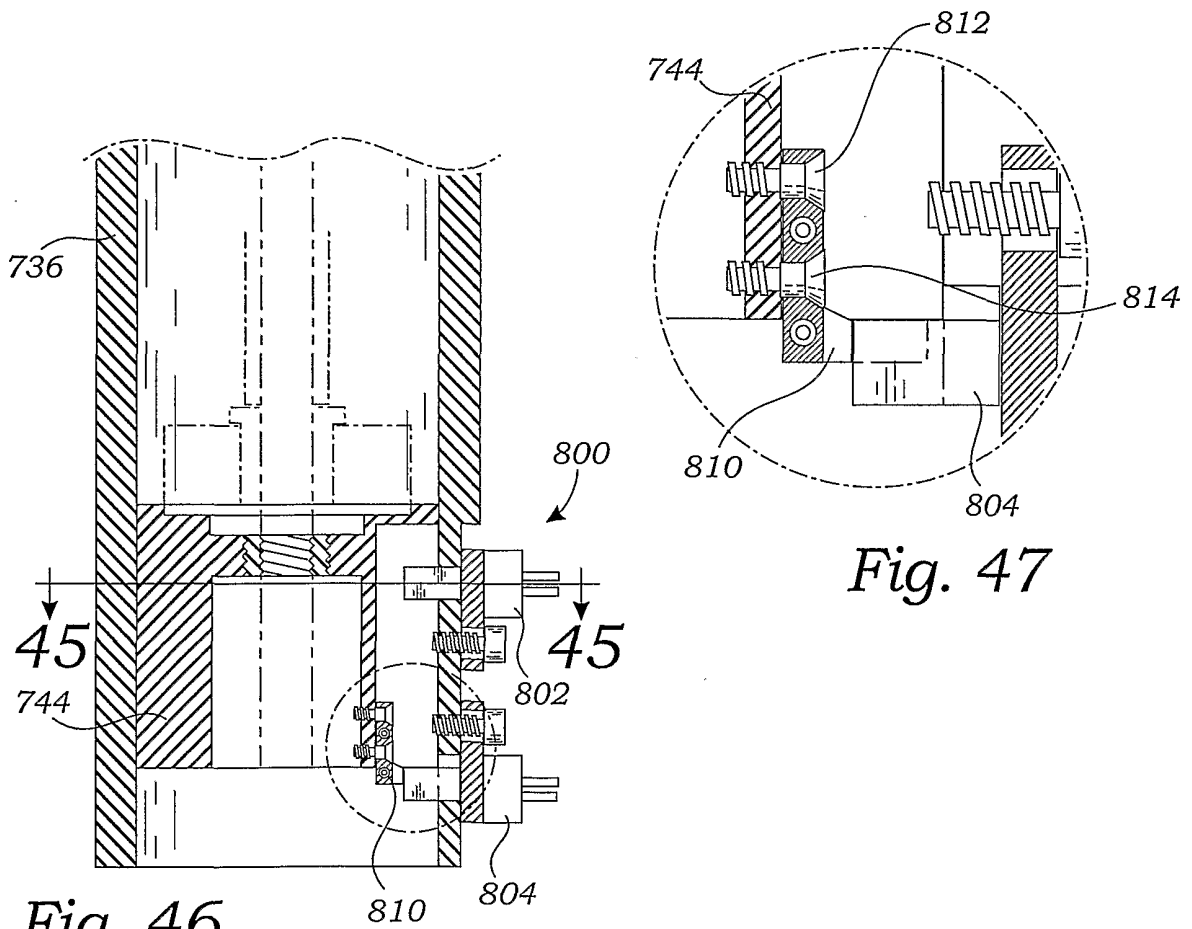

Fig. 46

Fig. 47

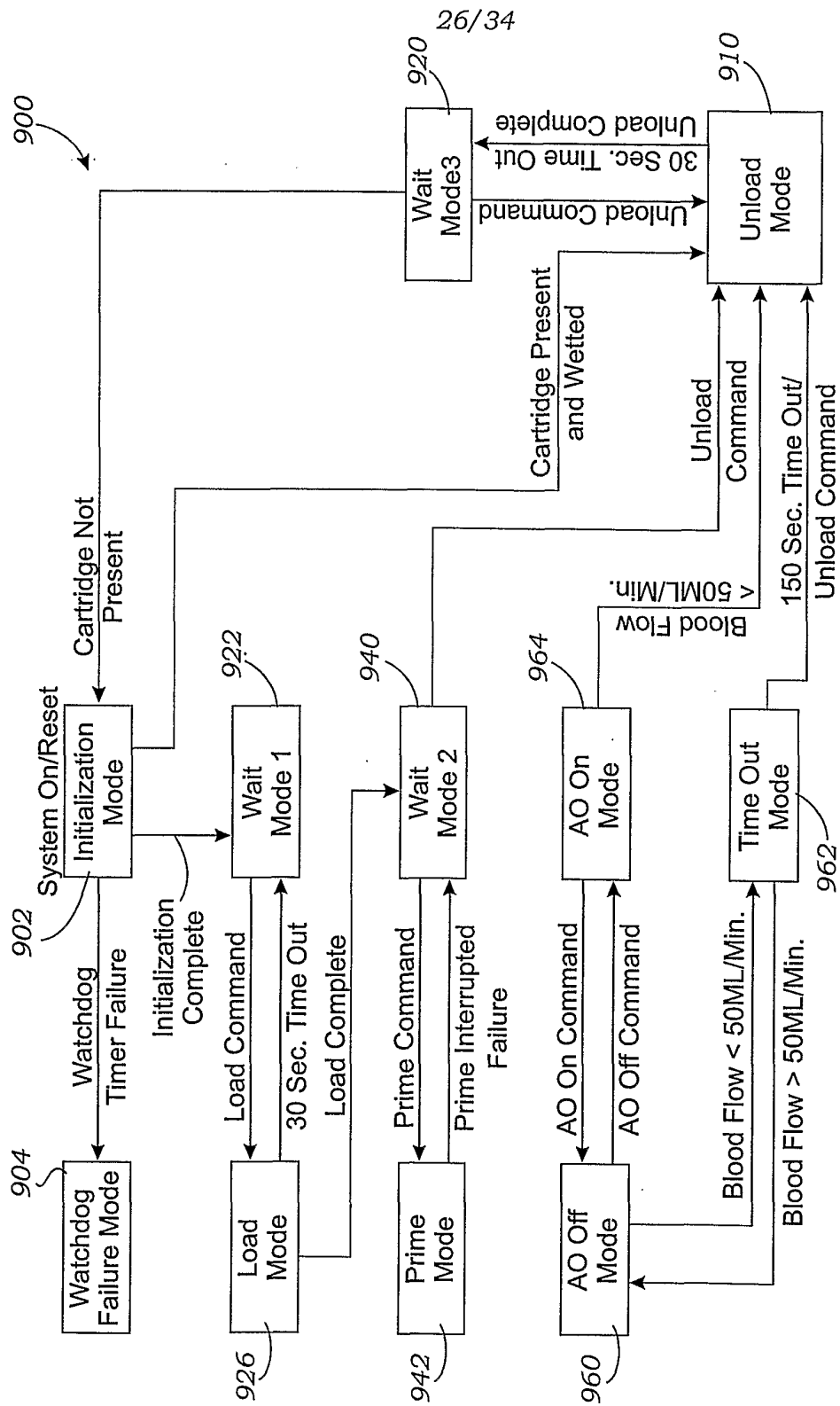

Fig. 49

27/34

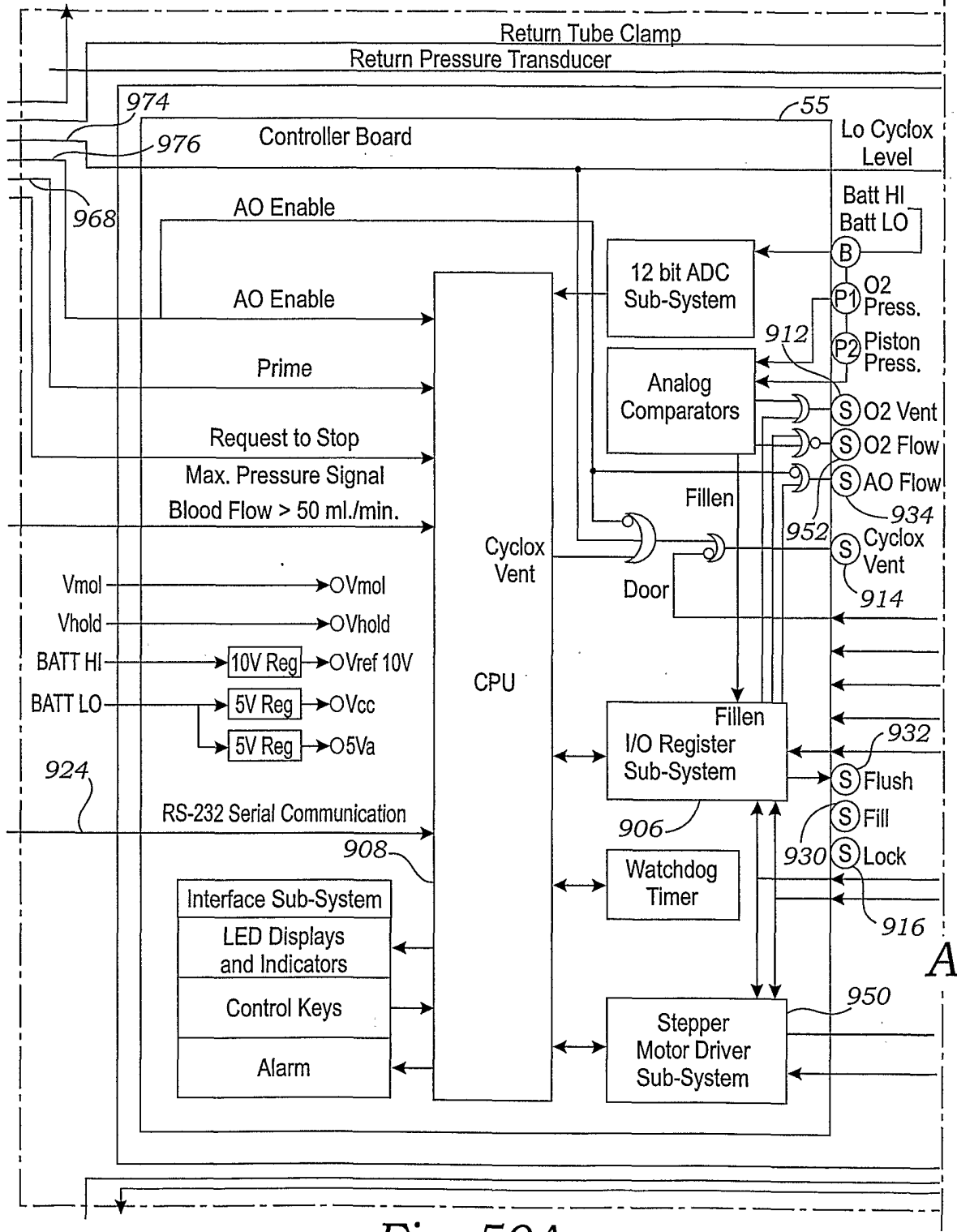

Fig. 50A

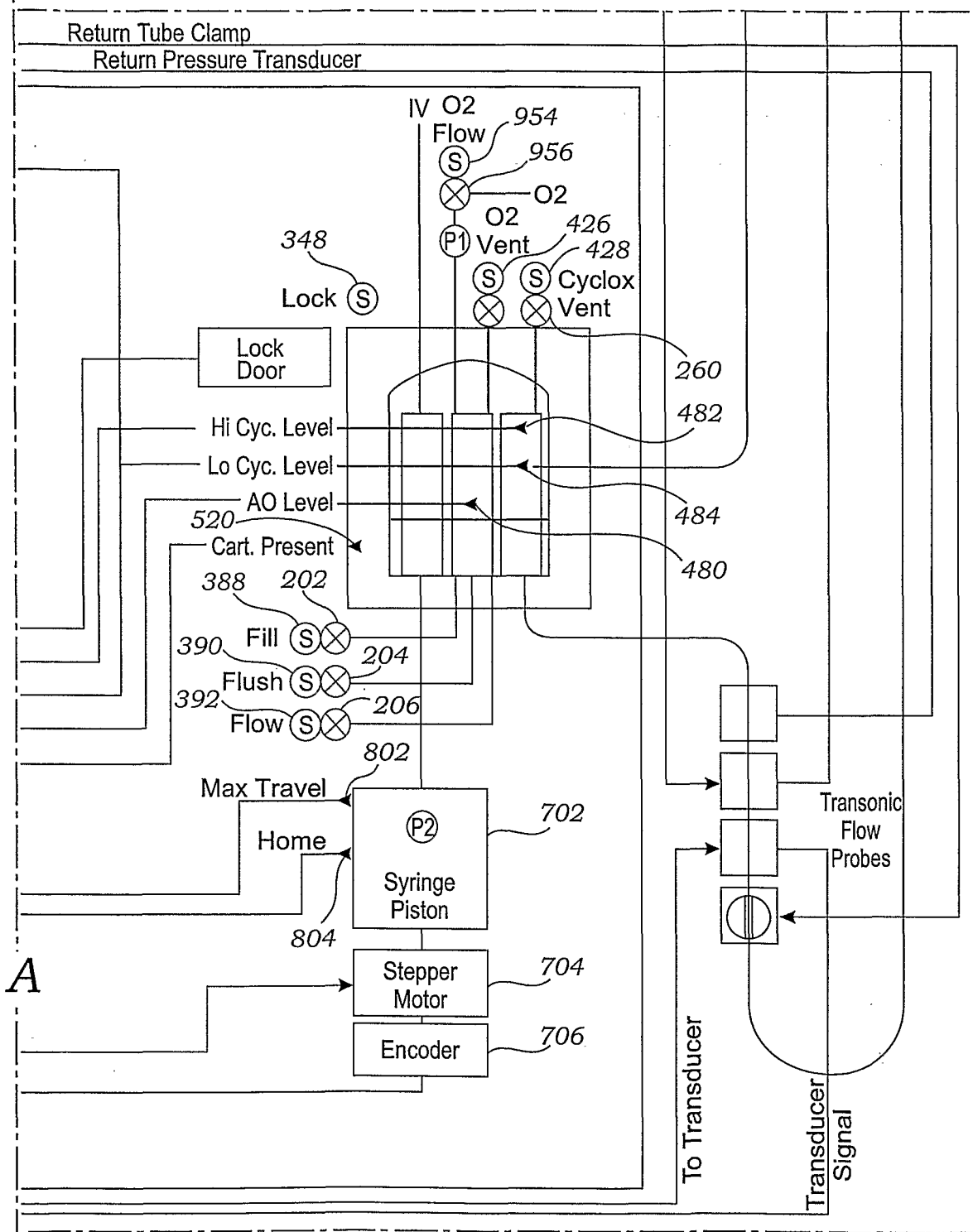

Fig. 50B

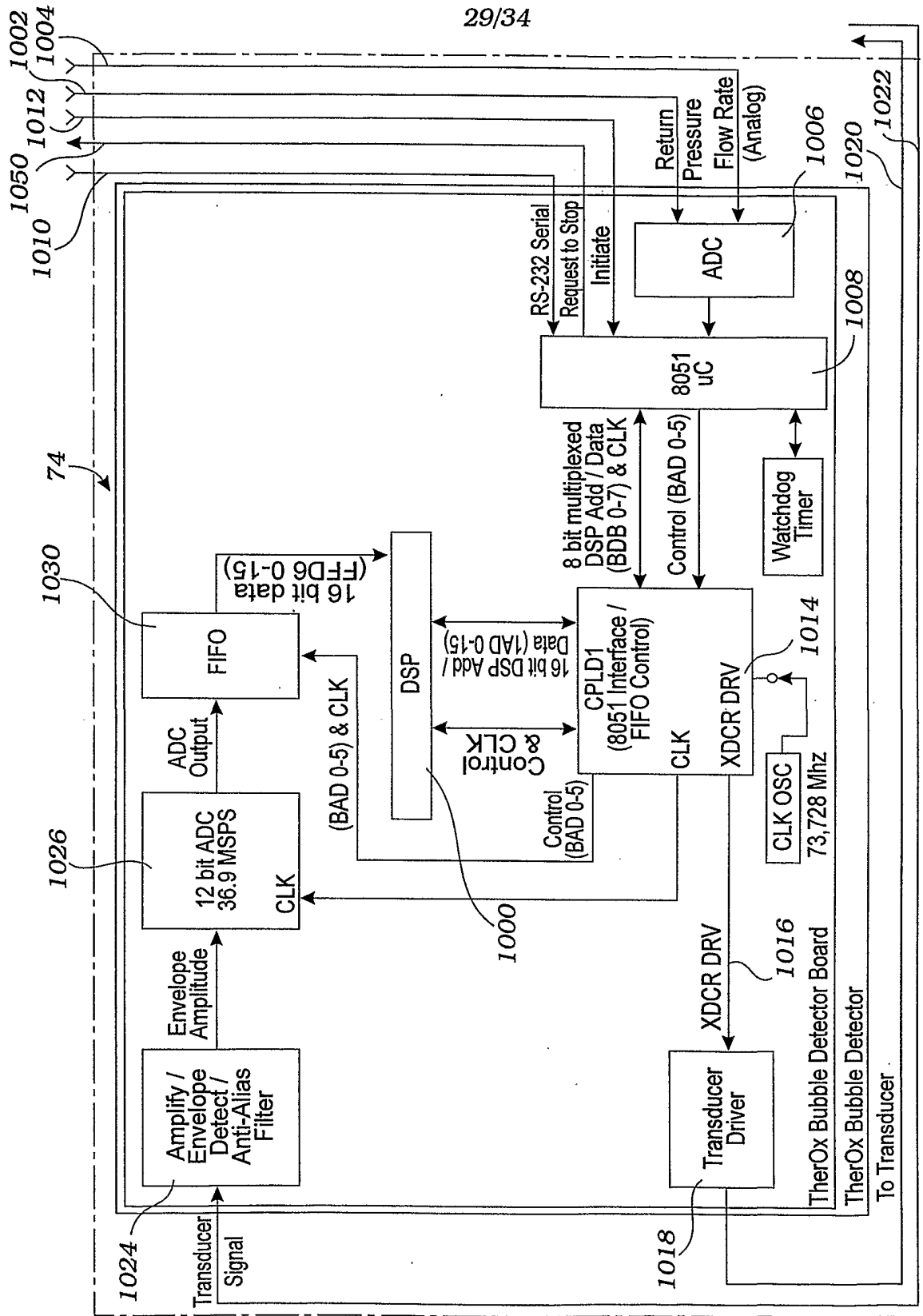

Fig. 51

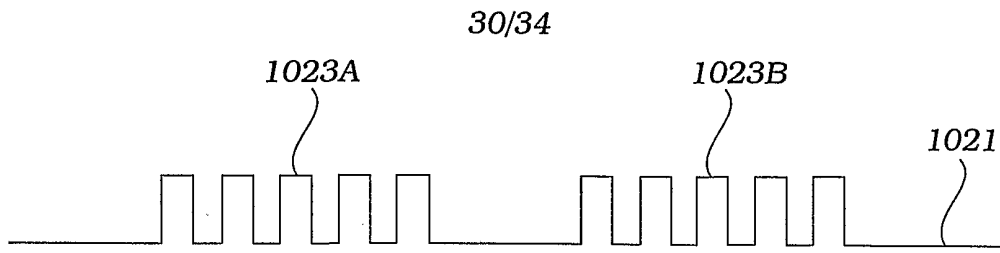

Fig. 52

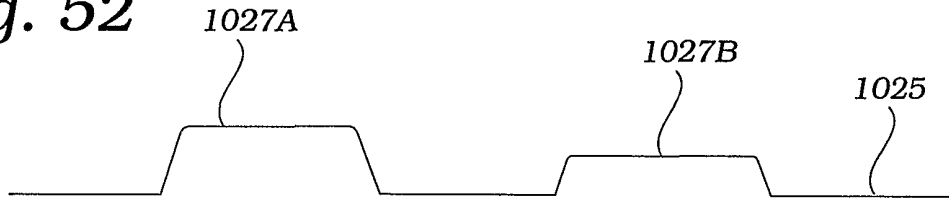

Fig. 53

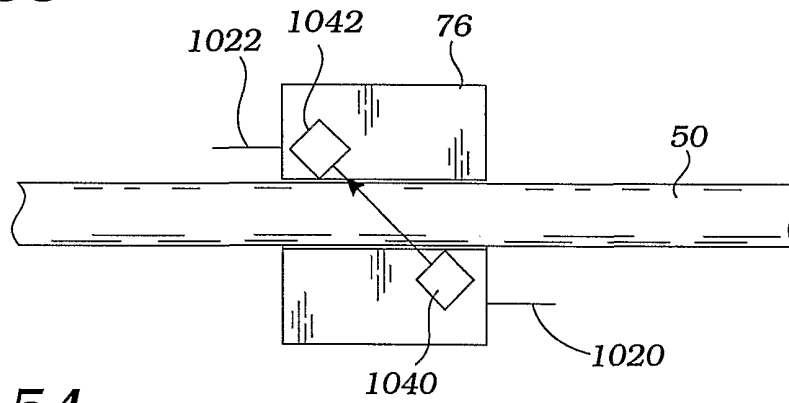

Fig. 54

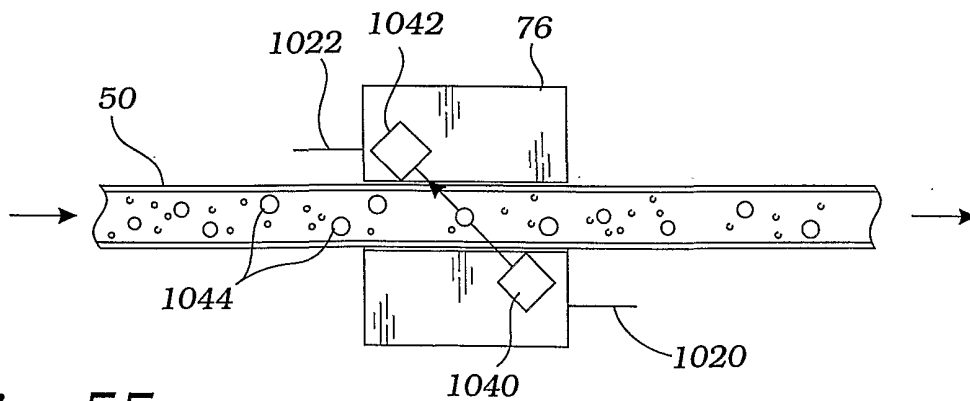

Fig. 55

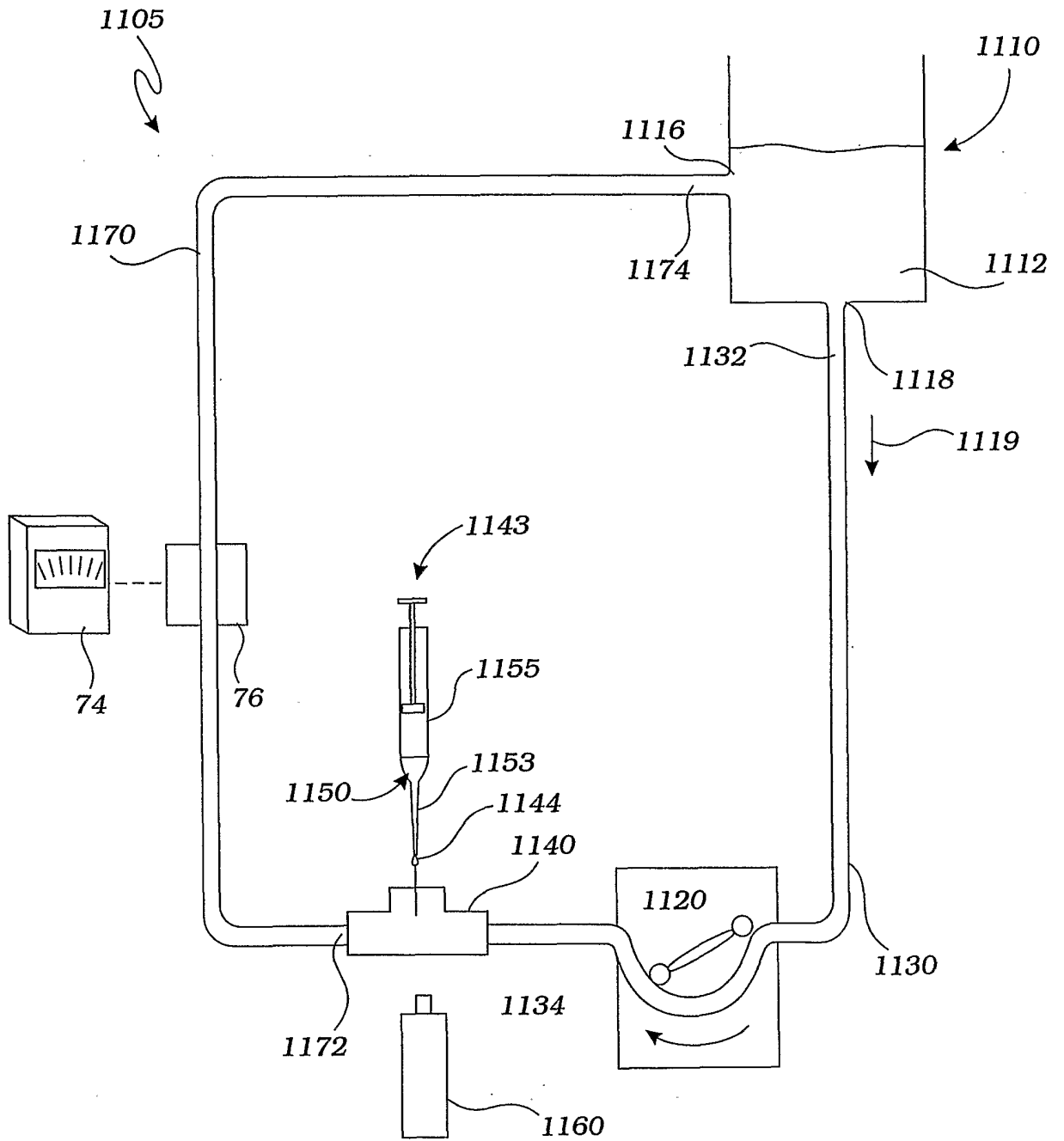

Fig. 56

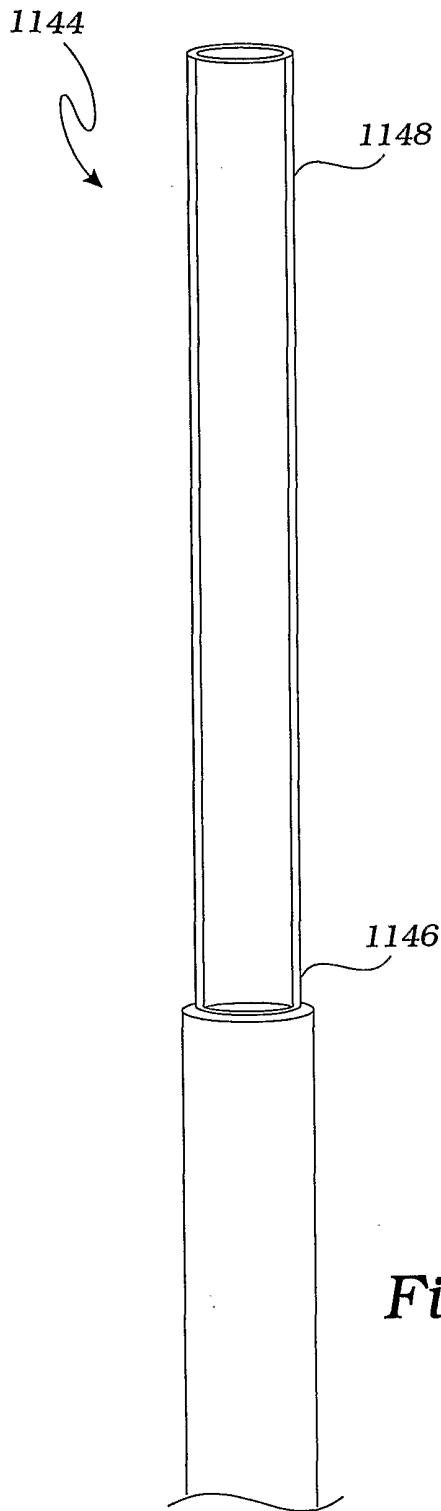

Fig. 57

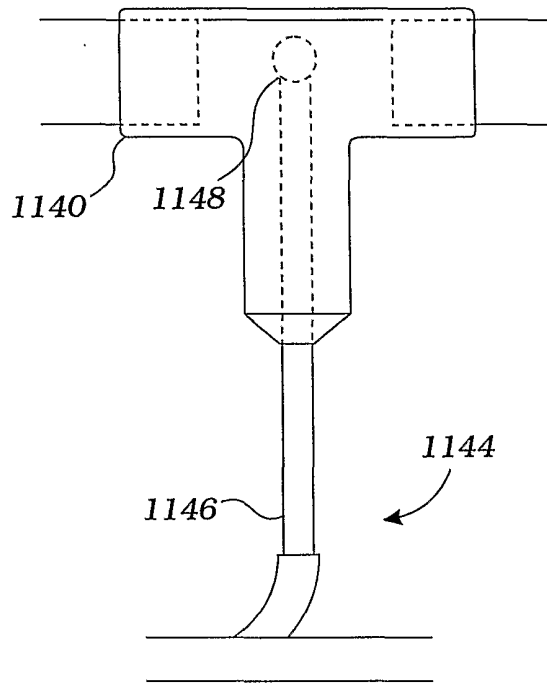

Fig. 58

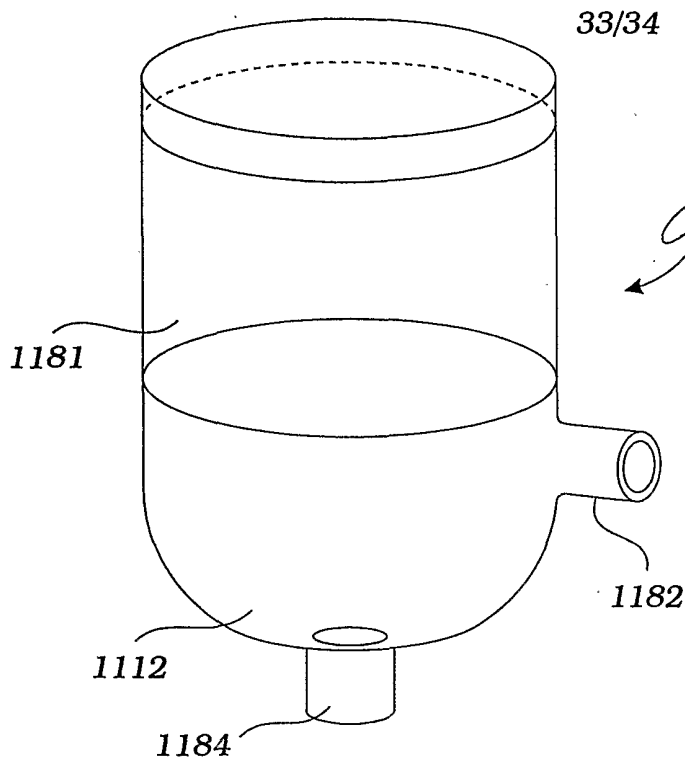

Fig. 60

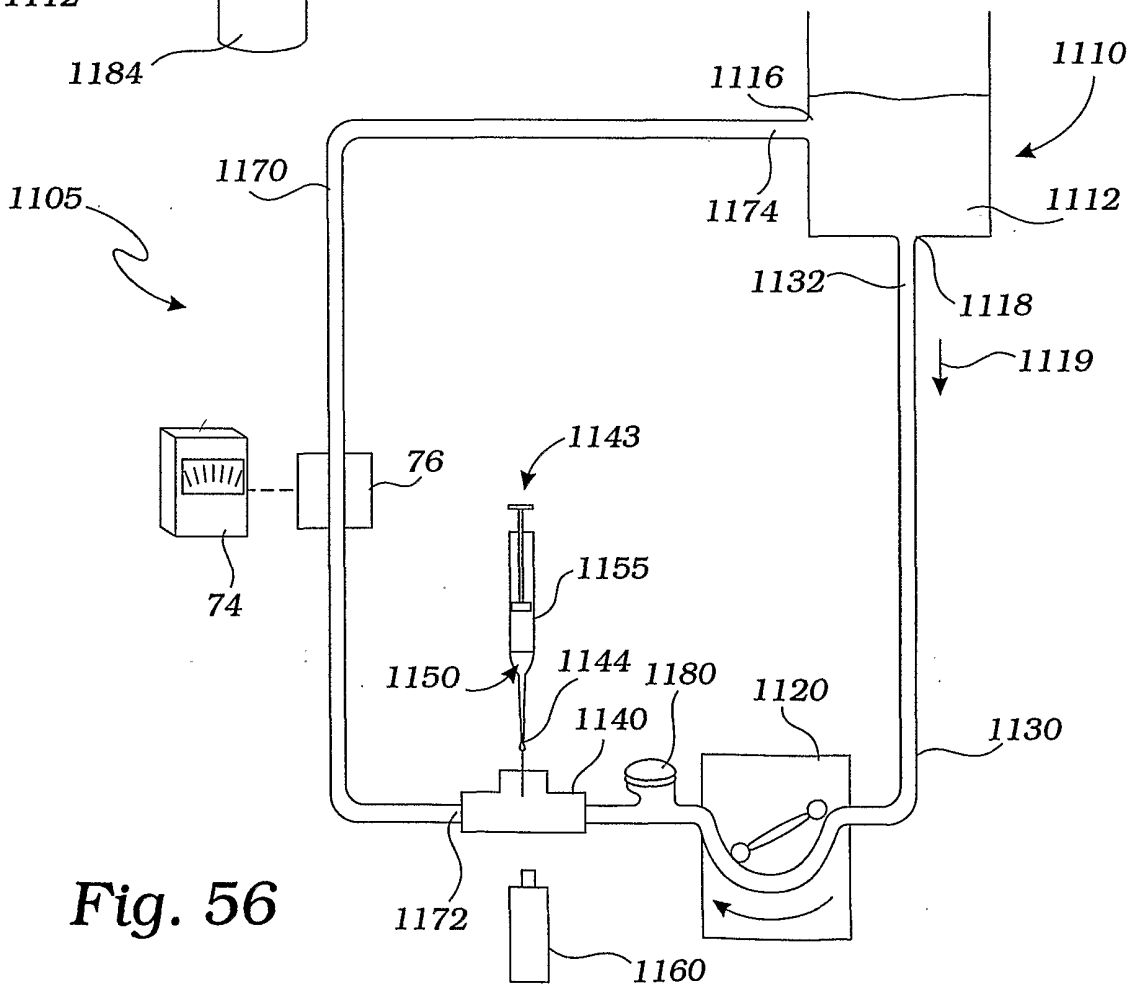

Fig. 56

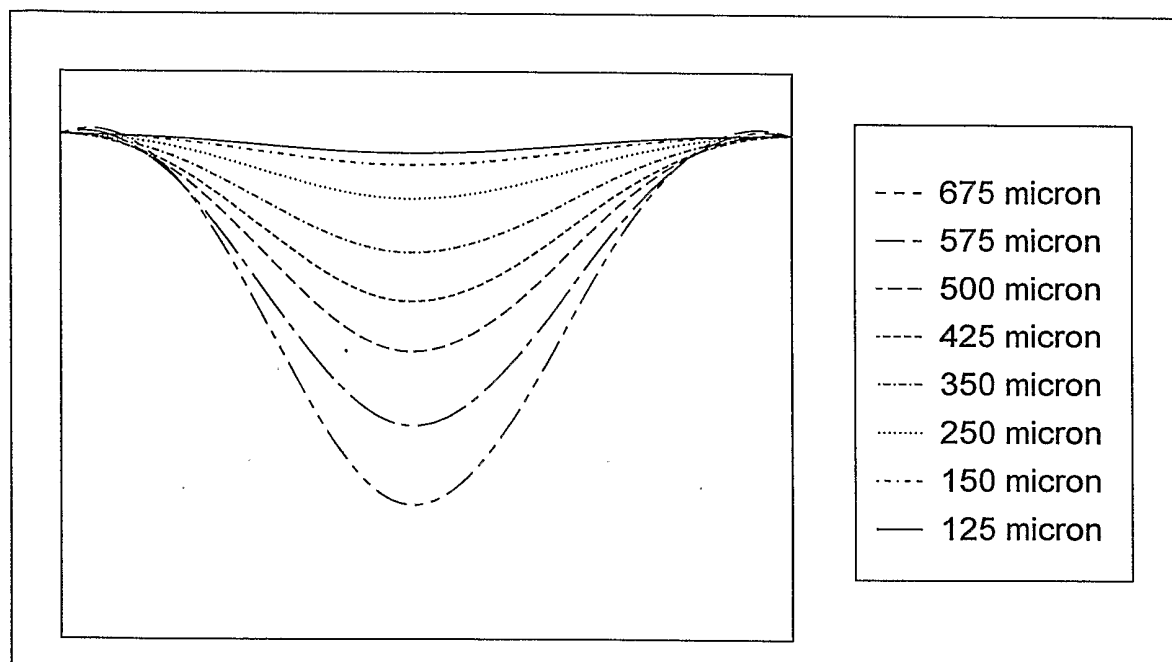

Fig. 61