

(No Model.)

8 Sheets—Sheet 1.

S. E. DAVIS.
VOTING MACHINE.

No. 526,668.

Patented Sept. 25, 1894.

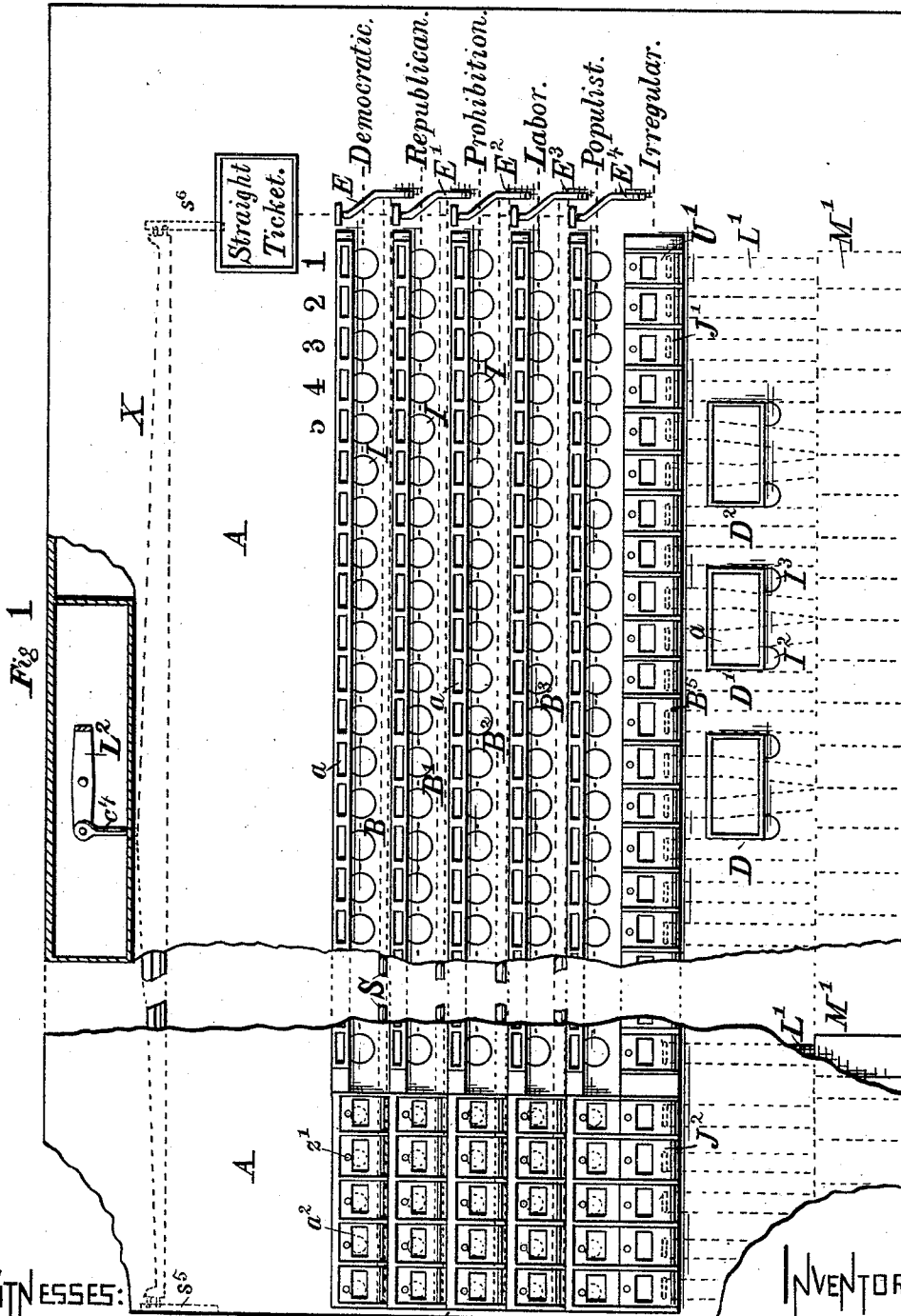

WITNESSES:
Geo. Wilson.
H.C.H. Cooper.

INVENTOR:
S. E. Davis,
 By *Geo. B. Selden, atty.*

(No Model.)

8 Sheets—Sheet 2.

S. E. DAVIS.
VOTING MACHINE.

No. 526,668.

Patented Sept. 25, 1894.

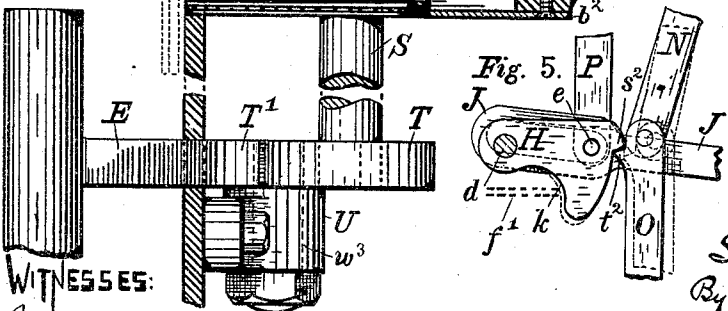
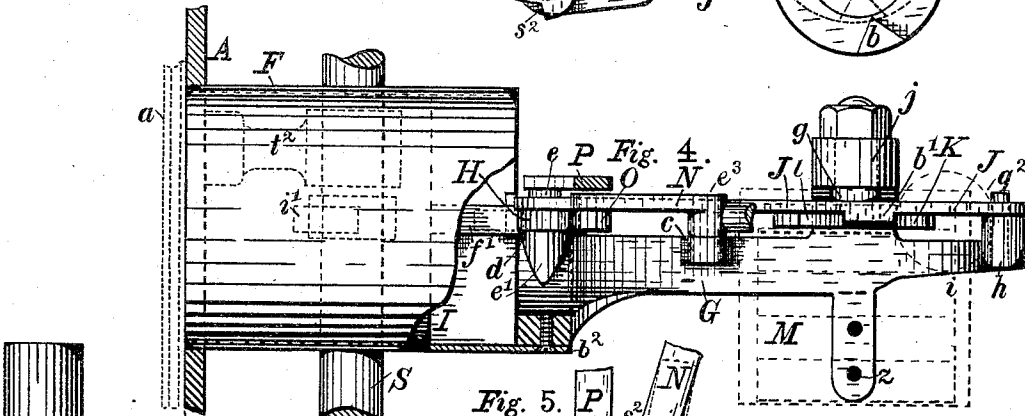
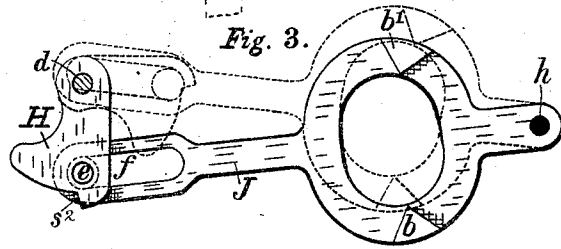
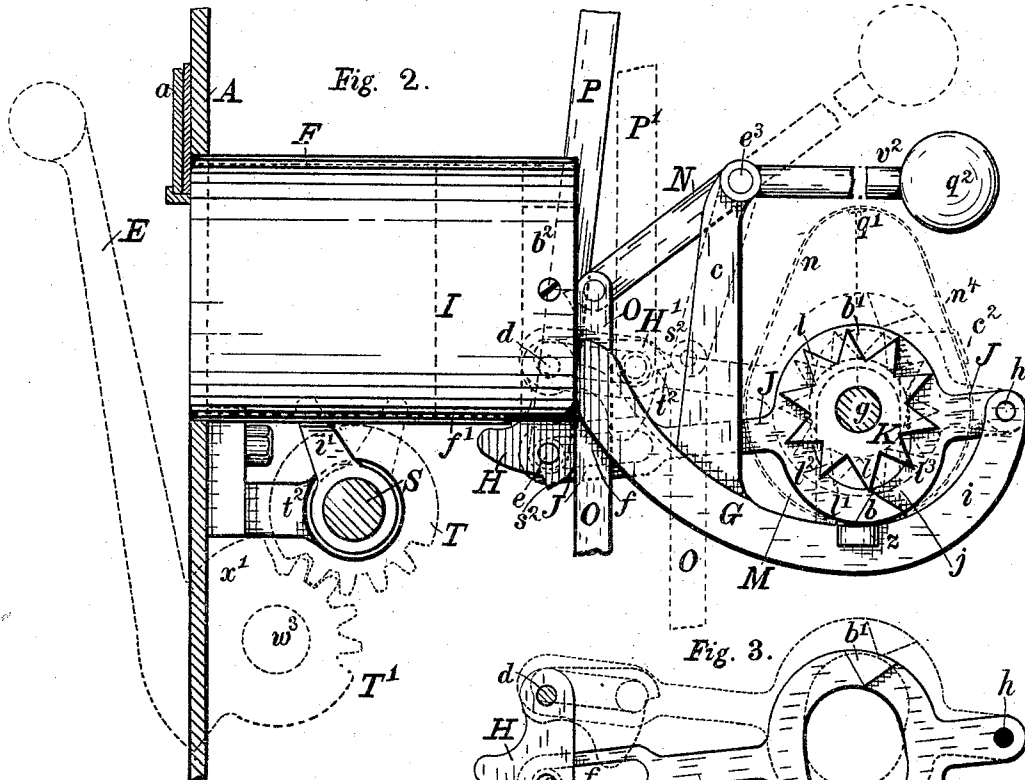

WITNESSES:
Geo. Wilson.
H. C. Cooper.

INVENTOR:
 S. E. Davis,
 By Geo. B. Selden,
 atty.

S. E. DAVIS.
VOTING MACHINE.

No. 526,668.

Patented Sept. 25, 1894.

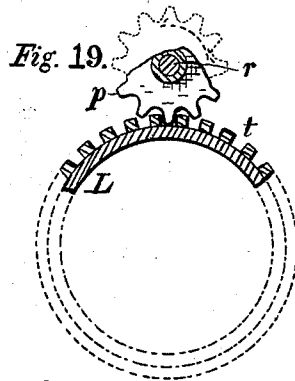
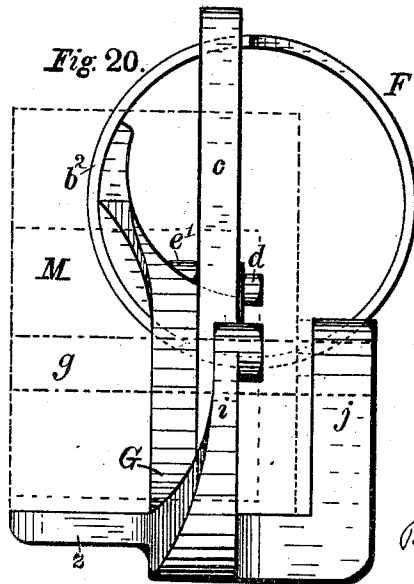
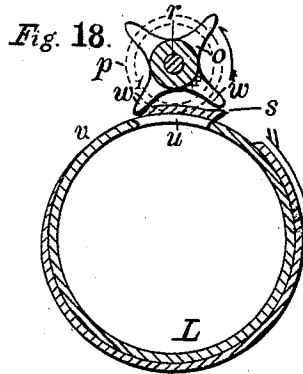
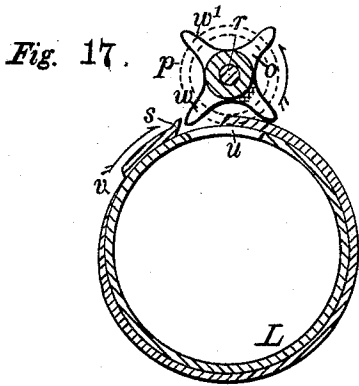
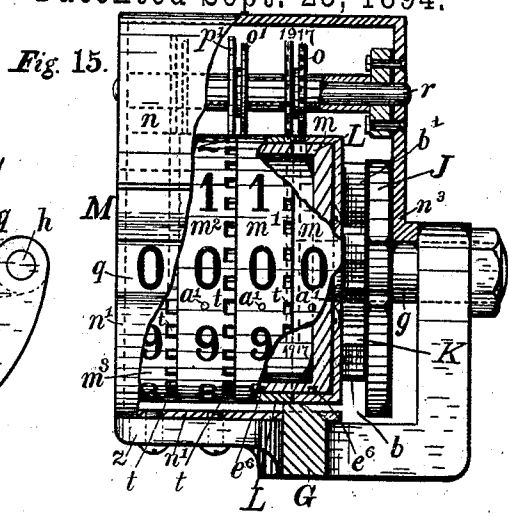
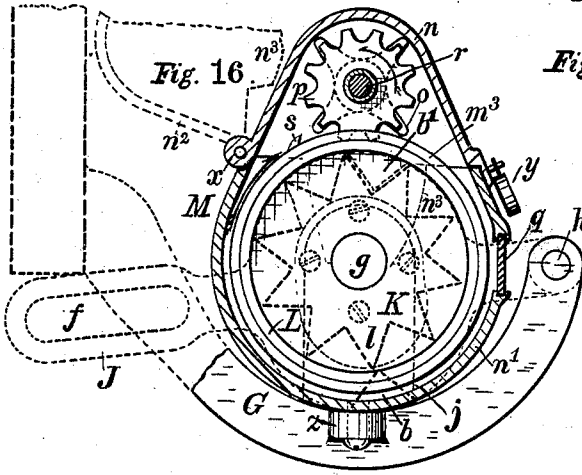

WITNESSES:
 Geo. Wilson.
 H. C. Cooper.

INVENTOR:
 S. E. Davis,
 By Geo. B. Selden,
 atty.

S. E. DAVIS.
VOTING MACHINE.

No. 526,668.

Patented Sept. 25, 1894.

Fig. 21.

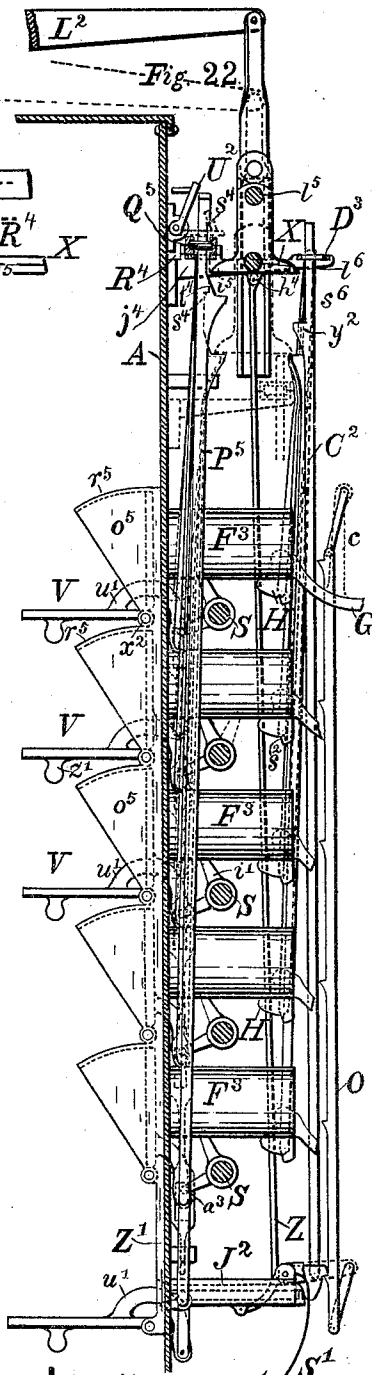
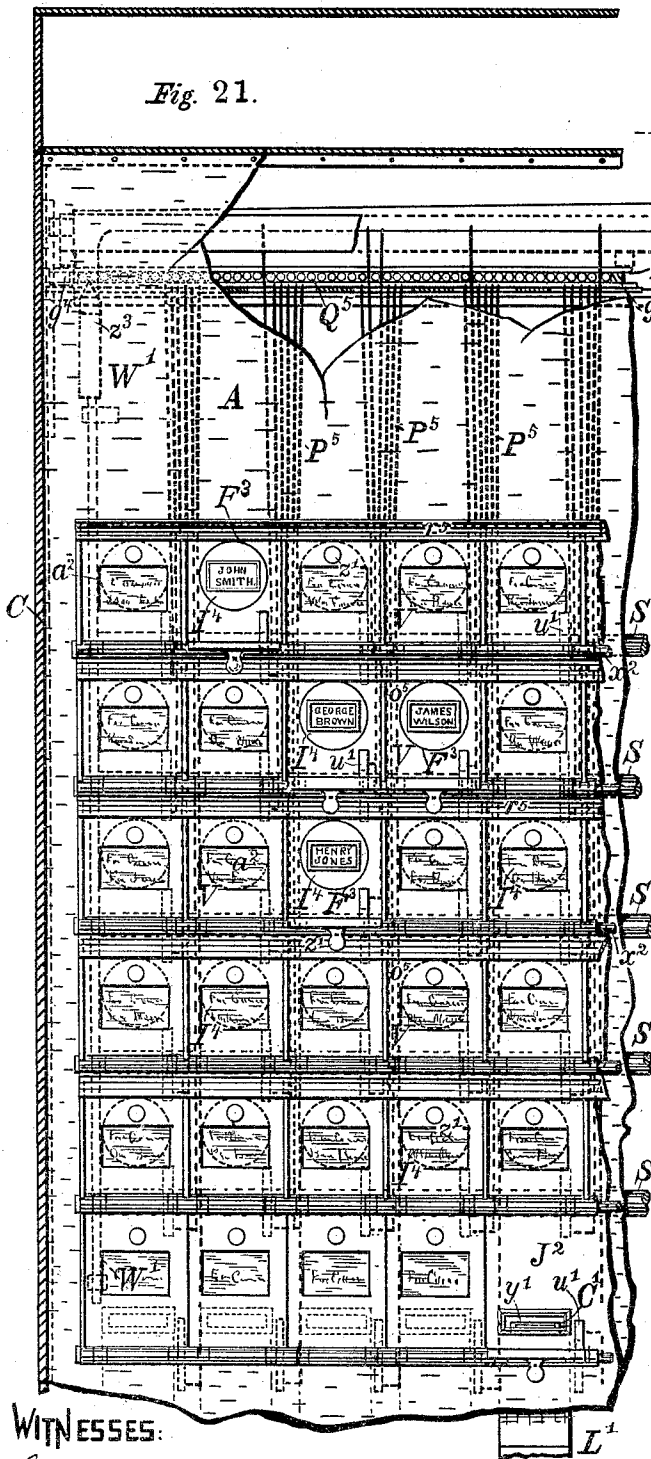

WITNESSES:

Geo Wilson
H.C. Cooper.

INVENTOR:

S. E. Davis,
By Geo. B. Selden,
att_y-

(No Model.)

8 Sheets—Sheet 6.

S. E. DAVIS.
VOTING MACHINE.

No. 526,668.

Patented Sept. 25, 1894.

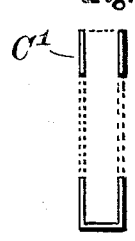
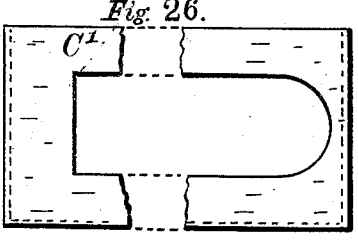
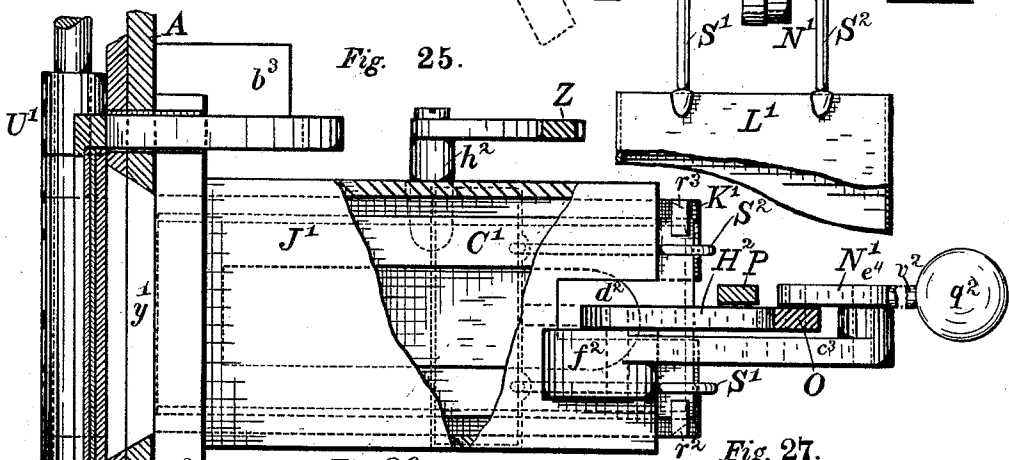
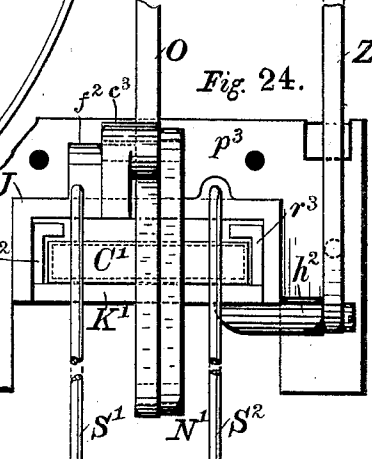
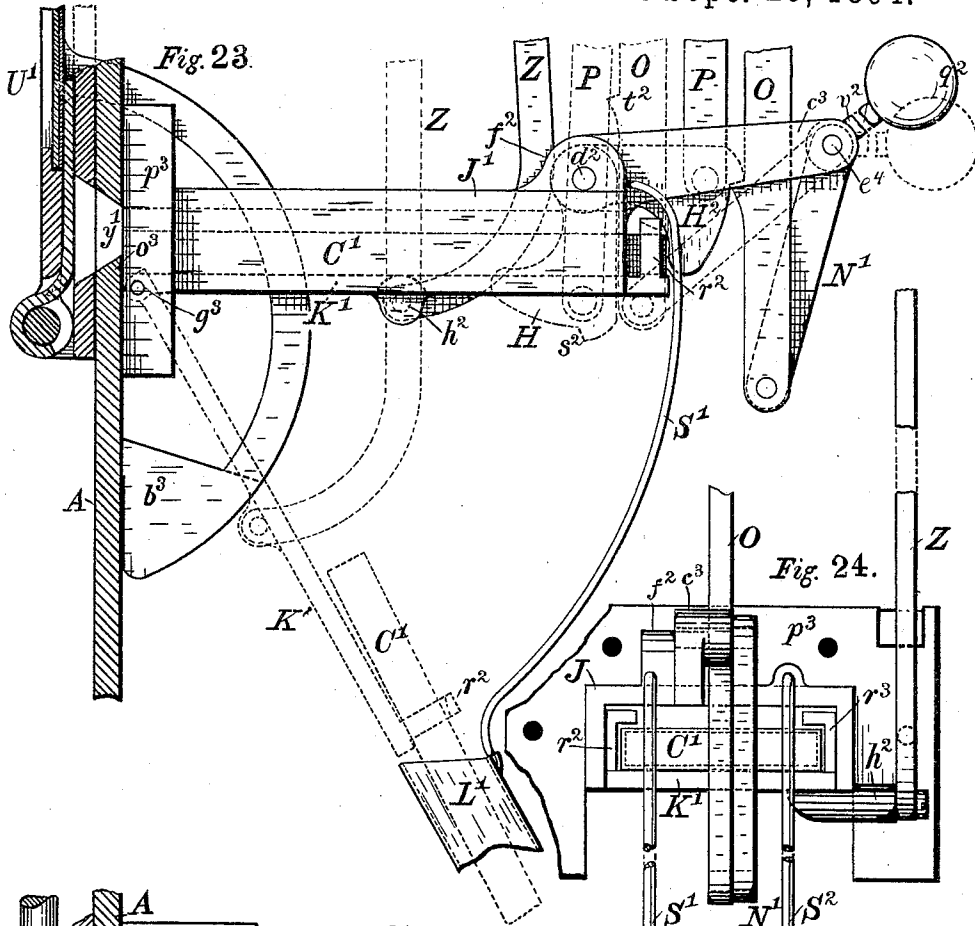

WITNESSES:
Geo Wilson
H. C. Cooper

INVENTOR:
S. E. Davis,
 By *Geo. B. Selden.*
att'y.

S. E. DAVIS.
VOTING MACHINE.

No. 526,668.

Patented Sept. 25, 1894.

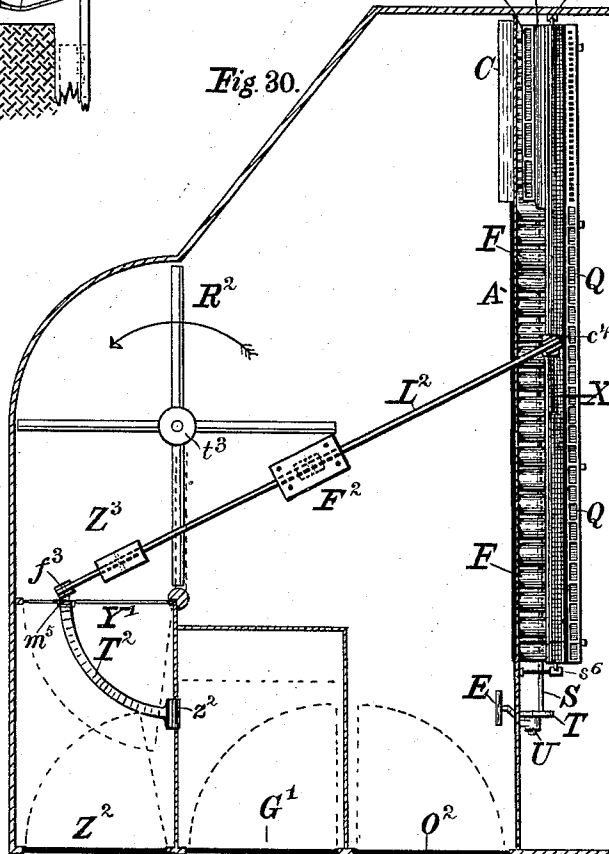
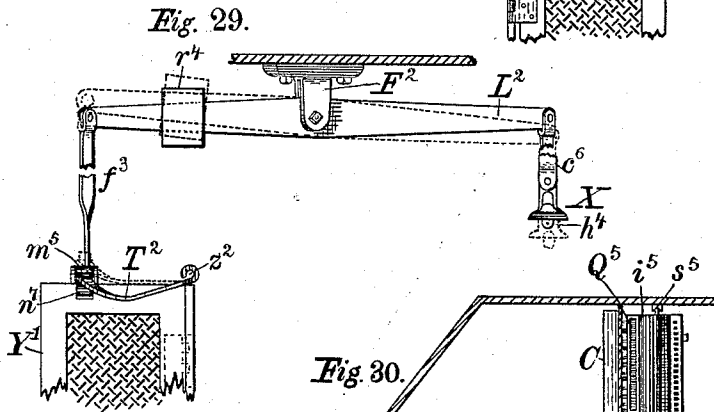
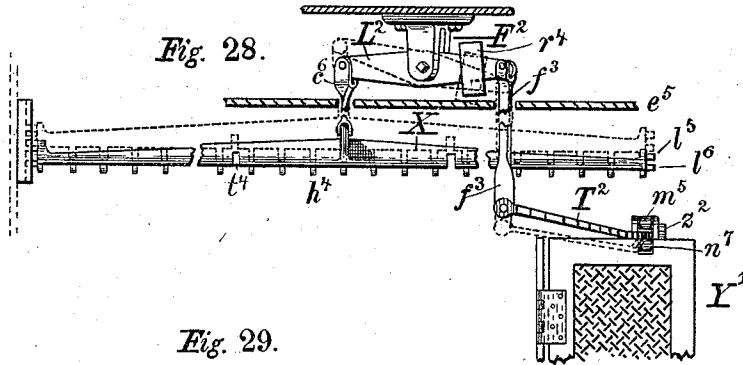

WITNESSES:

Geo. Wilson
H. C. Cooper

INVENTOR:

S. E. Davis,
By
Geo. B. Selden,
Atty.

S. E. DAVIS.
VOTING MACHINE.

No. 526,668.

Patented Sept. 25, 1894.

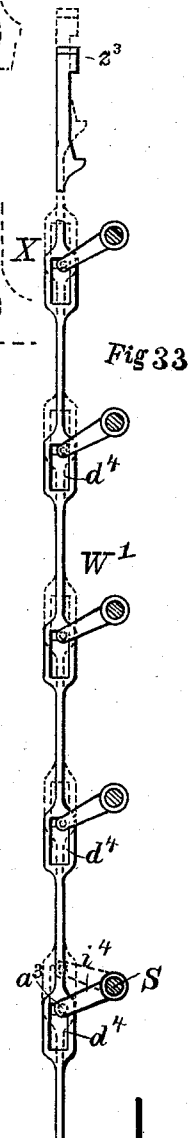
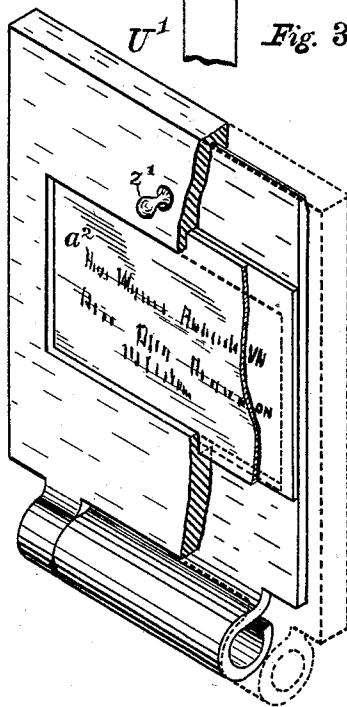
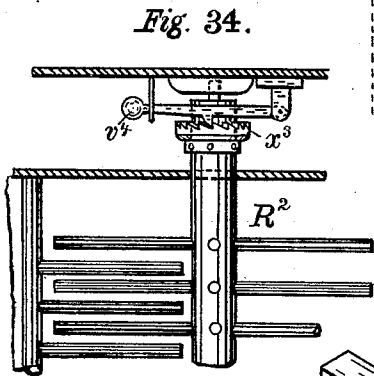
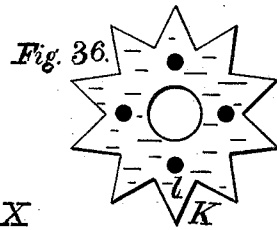
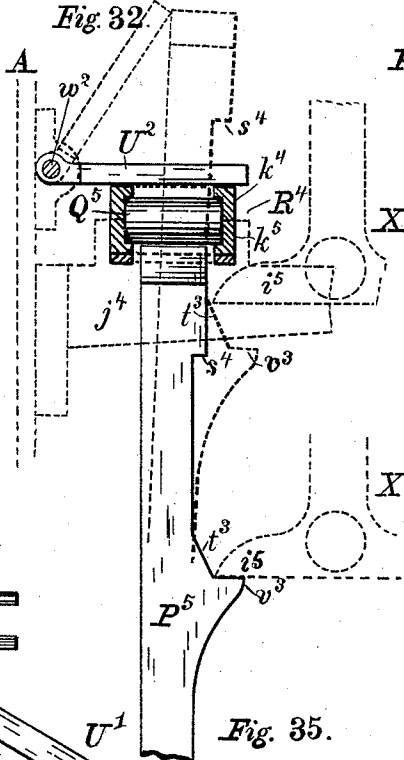
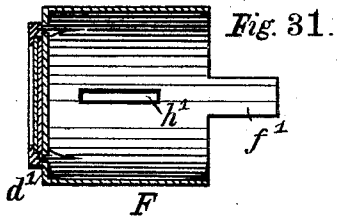

WITNESSES:
Geo Wilson
H.C. Cooper.

INVENTOR:
S. E. Davis,
 By *Geo. B. Selden,*
att'y.

UNITED STATES PATENT OFFICE.

SYLVANUS E. DAVIS, OF ROCHESTER, NEW YORK, ASSIGNOR OF FIFTY-ONE ONE-HUNDREDTHS TO GEORGE WILSON AND GEORGE B. SELDEN, OF SAME PLACE.

VOTING-MACHINE.

SPECIFICATION forming part of Letters Patent No. 526,668, dated September 25, 1894.

Application filed June 13, 1894. Serial No. 514,427. (No model.)

To all whom it may concern:

Be it known that I, SYLVANUS E. DAVIS, a citizen of the United States, residing at Rochester, in the county of Monroe, in the State of New York, have invented an Improved Voting-Machine, of which the following is a specification, reference being had to the accompanying drawings.

My invention relates to an improved voting-machine,—the construction and operation of which are fully described and illustrated in the following specification and the accompanying drawings,—the novel features thereof being specified in the claims annexed to the said specification.

The object of my invention is the production of a voting machine,—a machine for enabling the public to vote at ordinary elections without printed ballots,—which shall be beyond the possibility of failure from mechanical causes,—to secure which result all the moving devices between the push or part actuated by the voter and the registering devices which indicate the number of votes cast, are constructed so that they are at all times in positive mechanical engagement with each other, and so that no movement of the counting mechanism is possible, except that imparted to it by the voter.

My invention also involves the absolute prevention of fraudulent voting, the provision of means for voting for irregular candidates, for voting on questions, and for voting for offices where two or more candidates are presented by the same political party,—all as hereinafter more fully described.

In the accompanying drawings representing my improvements in voting machines,—Figure 1 represents the partition or wall in the voting booth showing the arrangement of the pushes by which the voting is effected. Fig. 2 is a side-elevation of the counter-actuating mechanism. Fig. 3 represents the oscillating sector and the counter-lever detached. Fig. 4 is a plan view of the counter-actuating mechanism. Fig. 5 represents the sector locked in engagement with the locking-bar. Fig. 6 is a side elevation of one of the vertical lines of pushes, showing also the interlocking mechanism. Fig. 7 is a rear elevation of the same. Fig. 8 is a plan view of

the interlocking rollers and their supporting frame. Fig. 9 is a longitudinal section of the same on the line 9—9, Fig. 8. Fig. 10 is a transverse section of the same on the line 10—10, Figs. 8 and 9. Fig. 11 is a longitudinal section of the interlocking mechanism of the pushes employed for voting on questions. Fig. 12 represents the block or blocks which may be substituted for one or more of the interlocking-rollers, to render one or more of the voting devices inoperative. Figs. 13 and 14 are respectively a longitudinal section and a plan of the support for the upper ends of the resetting-rods of the group of pushes employed when two or more candidates for the same office are presented by the same party. Fig. 15 is a rear-elevation, partially in section, of the counter,—its casing being partially broken away. Fig. 16 is a side elevation of the counter, as seen from the left-hand in Fig. 15,—the end of the casing being omitted. Figs. 17 and 18 are sections on the line 17—17, Fig. 15, representing the operation of the star-pinion which transmits movement from one of the counter-rings to the next adjacent ring. Fig. 19 is a section on the line 19—19, Fig. 15, showing the gear-wheel and the ring of teeth on the counter-ring. Fig. 20 is a rear elevation of one of the tubes which carry the pushes, and the bracket which supports the counter. Fig. 21 is a front elevation of the voting mechanism employed when more than two candidates for the same office on the same ticket are to be voted for. Fig. 22 is a side elevation of the same, showing also the locking mechanism and the resetting-bar. Fig. 23 is a side elevation of the irregular balloting-mechanism. Fig. 24 is a rear elevation of the same. Fig. 25 is a plan view of the same. Figs. 26 and 27 are respectively a side view and a transverse section of the ballot-holder. Fig. 28 represents the resetting-bar and the mechanism for operating the same detached. Fig. 29 is a side view of the same. Fig. 30 is a plan view of the booth,—the top being removed. Fig. 31 is a horizontal section of one of the slides or pushes. Fig. 32 is a side view of the upper ends of the interlocking rods of the doors. Fig. 33 is a side view of the locking-rod of the multi-candidate group. Fig. 34 represents the

ratchet and pawl on the turnstile. Fig. 35 represents the doors of the multicandidate group. Fig. 36 represents the star or toothed wheel detached.

5 In the practical use of my invention, the voter, on being admitted to the voting booth, finds before him an upright wall or partition in which the slides or pushes which actuate the counting mechanisms are arranged in
10 horizontal rows,—each row containing the pushes corresponding to all the candidates of any one political party, and there being as many rows as there are parties with an additional row of devices for irregular voting.
15 The voting is done by pushing in the slides or pushes for the preferred candidates,—the outer ends of the pushes being normally flush with the wall. Each row of pushes is provided with a suitable placard, indicating
20 which party it represents, and if desired, the surface of the wall or partition adjacent to the rows of pushes may be painted or otherwise colored lengthwise with a color which indicates to which party it belongs,—each of
25 the different parties being designated by a different color.

As indicated in Fig. 1, the name of the party, the names of whose candidates are arranged in any of the rows of pushes, may be
30 printed or otherwise displayed opposite such row;—or such name may be placed between the rows.

In the accompanying drawings A represents the wall or partition, and B B' B² B³
35 the rows of pushes corresponding to the candidates for the different parties. There is also a row of devices, B⁵, devoted to voting for irregular candidates, or such as are not nominees of any of the regular parties. The
40 voting for such irregular candidates is by written or printed ballots, as hereinafter described. There are also one or more groups of pushes, C, for electing candidates for any
45 office where there are two or more to be elected by the same party,—as for instance, coroners, constables, or inspectors of election,—which group or groups I have designated herein by
50 the word multicandidate, and which are preferably arranged at one end of the partition, the names of all such candidates of any one party however being placed in the same row
55 with those of the other candidates of the same party so that all the candidates of any one party can be voted for by a single movement of a lever, as hereinafter described.
60 There is also a series of pushes, D D' D² designed for voting on questions, such as the adoption of constitutional amendments, &c. All the pushes are provided with suitable
65 placards, a, giving the office and the name of the candidate for which a vote may be cast, by operating the adjacent push, or the question which is to be decided by the election, the pushes for each question being two in
number and designated by "For" and "Against," or "Yes" and "No," or some
equivalent words. There is also a single

lever by which all the pushes in the row devoted to any one party may be operated, such arrangement enabling a voter to vote a
70 "straight ticket" with the least possible delay. In Fig. 1 these straight ticket levers are indicated at E, E', E², E³, one being provided for each party, and located preferably
75 at the end of the partition next the entrance door.

The candidates for the same office by the different parties are arranged in vertical lines. Thus, at presidential elections, the first vertical
80 line 1, next to the straight-ticket lever, E is preferably devoted to the presidential electors, the next, 2, may be used for governor, the next for lieutenant governor, and so on down
85 the list of candidates,—it being understood of course that in case the number of candidates is less than the number of pushes in my machine, the placards will be left off the unnecessary
90 pushes, and that such pushes will be covered or otherwise arranged as hereinafter described to render them inoperative.

The voter who desires to vote a straight ticket, for any of the parties pulls the corresponding lever E, E', E², E³ outward and
95 downward and such movement operates all the pushes in any one row, and actuates the corresponding counters, so that a vote is registered for all the candidates nominated by
100 any one party. The inward movement of any of the pushes, locks all the other pushes in the same vertical line, (except in group C,) so that when a voter has voted for the candidate of
105 any one party for any particular office, he cannot vote for the candidate of any other party for the same office. Thus, in the arrangement shown in Fig. 1, if the voter pushes in the push
110 or plunger in the upper row B of line 1, he will register a vote for the democratic candidate for the office to which line 1 is devoted, and he cannot vote for any of the other candidates
115 for such office, nor can he make use of the irregular balloting device,—all the lower pushes in line 1 being locked by the movement of the upper push, so that they cannot be
pushed inward. In a similar manner, if any of the pushes below the upper one be operated, all the others, above and below it, are
locked, so that it is impossible to register a vote for more than one candidate for any given office.

When the voter has voted a straight ticket
120 for any of the parties, by the use of the corresponding straight-ticket lever, as already described, he cannot vote a straight ticket for any of the other parties, nor can he vote for
125 any individual candidate of any of the other parties. The deposit of an irregular ballot for a candidate for any given office, also prevents voting for any regular candidate for the same office. The construction must also
130 be such that a second vote cannot be given for any given candidate. When the voter leaves the booth, having registered his vote, either straight, or by any preferred selection from among the candidates, he passes out

through a wicket-door, which, by its movement, resets the apparatus in condition for the next voter.

Proceeding now to a description of the vote-registering or counting mechanism, it is to be premised that, in this kind of machinery it must be absolutely positive in its operation, and that it must be entirely independent of the action of springs, or any other devices which may occasionally fail to work. For this reason I construct my registering mechanism in such manner that any inaccuracy or irregularity is a mechanical impossibility. It will be understood that each counting mechanism must receive an impulse which will count whenever its push or plunger is pushed inward. To make this movement of the push register the corresponding vote with unfailing accuracy, and at the same time to lock all the pushes in any one vertical line against inward movement, when one of the pushes in such line is operated, I have invented the following construction:

F, Figs. 2 and 3, represents a tube inserted in the wall or plate A, and serving to support the push I, which is arranged to slide freely within the tube, and which tube also sustains the bracket G, which carries the counting mechanism. The push is preferably tubular, having a solid outer end, d' , Fig. 31, and an arm f' , which contacts with the sector H. The inward movement of the push I vibrates the sector H, and oscillates the counter-lever J, which actuates the star-wheel K one-tenth of a revolution at a time, which movement is transmitted to the counting or registering mechanism. The counter-lever J is provided with the pallets $b b'$, which engage alternately with the teeth l of the star-wheel K, and impart to it positively an intermittent movement at each oscillation of the counter-lever. This construction dispenses with dogs, pawls or springs, and renders the transmission of the movement of the push to the counter entirely certain and positive. The sector is pivoted to the bracket G at d . The sector is provided with a pin or stud e which engages in a slot f in the inner end of the counter-lever J. The counter lever is pivoted at h to the outer end of the arm i of the bracket G. The movement of the sector H and counter-lever J when operated by the push I is indicated by the full and dotted lines in Figs. 2 and 3. The star wheel and counter are supported on a stud g inserted in an arm j on the bracket G. The sides of the pallets $b b'$ are inclined, and the arrangement is preferably such that the upward movement of the counter-lever imparts the counting-movement to the star-wheel and the counting-mechanism,—the downward movement serving only to move the star-wheel slightly so that the next tooth engages properly with the lower pallet b on its next upward motion. Thus, the lever being down, as indicated by the full lines in Fig. 2, the pallet b when moved upward shifts the tooth l of the star-wheel to l' ,—this move-

ment actuating the counting-mechanism,—while the downward movement of the pallet b' acts on the wheel so as to shift the tooth from l' to l^2 , bringing the next tooth in position to be actuated by the next upward movement of the pallet b . The counting motion may however be obtained from the downward movement of the counter-lever, if preferred or the movement may be derived equally from both pallets. The counter lever is widened and provided with an opening which permits the passage of the stud g carrying the toothed wheel K through it, the pallets $b b'$ being attached to the widened part in position to engage with the teeth of the star-wheel K on the opposite sides thereof. The inclined sides of the pallets slide along the teeth of the star-wheel which is actuated thereby. It will be observed that one or the other of the pallets $b b'$ is always engaged between the teeth of the star-wheel so that the movement of the latter is positive, and no movement of the star-wheel can take place except when it is actuated by the counter-lever. It is needless to remark that the absolute certainty of counting every time a voter operates a push secured by this construction, is indispensable to the successful use of a voting machine. The counter lever J passes alongside of the star-wheel, the pallets $b b'$ projecting from the side of the lever into the path of the teeth of the star-wheel or being attached thereto in any suitable way.

Any suitable registering or counting mechanism may be employed in connection with the star-wheel K, but, to secure absolute positiveness in the action of the counter, I prefer to employ the construction shown in Figs. 15 to 19 inclusive, in which the complete revolution of any one counter wheel or ring is transmitted positively to the next wheel or ring by a star-pinion and pinion in the following manner:—The stud g on which the star-wheel K revolves supports a cylinder L, Figs. 15 and 16, on which the counter-rings $m m' m^2 m^3$ are placed so as to revolve freely. The ring m is attached to the star-wheel K and partakes of its motion. The movement of the ring m is imparted, to the ring m' , at the completion of an entire revolution, by the star-pinion o and pinion p , so as to move the ring m' one-tenth of a revolution. In a similar manner, the complete revolution of the ring m' imparts one-tenth of a turn to the ring m^2 by star pinion o' and pinion p' and the ring m^2 similarly actuates the ring m^3 . The rings are provided with figures, running from 0 to 9, which are visible from the rear through a transparent plate q in the casing surrounding the counter M. With four counter-rings, as shown, a vote may be registered up to nine thousand nine hundred and ninety-nine. A fifth ring would increase the capacity of the machine, if desired.

The star-pinion o and pinion p are supported on a shaft r sustained by the counter-casing n . The ring m is provided with a pro-

jection or lip *s*, Figs. 17 and 18, which engages with one of the points of the star-pinion *o* and imparts to it a movement which is transmitted by the pinion *p*, to the ring *m'*. The pinion *p* and the teeth *t* on the edge of the ring *m'* with which it engages, are shown in the sectional view, Fig. 19. When the ring *m* is making the last tenth of a complete revolution, the ring *m'* is moved one tenth of a revolution. The cylinder *L* is cut away, as represented at *v*, Figs. 17 and 18, to permit the revolution of the star-pinion. The ring *m* is provided with a recess or depression, *v*, Figs. 17 and 18, into which the point of the tooth *w'* enters at the time the next preceding tooth *w* of the star-pinion *o* is passing over the lip *s*, as indicated in Fig. 18. This recess is tapered out to the surface of the ring *m*, so that the star-pinion is turned slightly backward as the ring continues to revolve, so that the star-pinion is locked by two of its adjacent points bearing on the ring, see Fig. 16, while at the same time one of the points is placed in position to be actuated by the lip *s* at the completion of the next revolution of the ring. The direction of the motion of the star-wheel *K*, the rings and the connecting devices is indicated by the arrows in the accompanying drawings. The counter-ring *m* is attached to the star-wheel *K* in any suitable way, as by the screws indicated in Figs. 15 and 16. The cylinder *L* is attached to the end of the stud *g* which sustains the star-wheel *K*. The outer end of the cylinder is supported in any suitable way by the end of the casing which surrounds the counter. The star-pinion *o* and pinion *p* are attached to each other so as to revolve together on the shaft *r*,—suitable collars being interposed between the pinions of the different counter-rings at suitable distances apart. The casing which surrounds the counter *M* is preferably divided, so as to afford access to the rings.

In the accompanying drawings, the upper part *n* of the casing, is hinged on the rear side at *x*, Fig. 16, to the lower part *n'* and attached to it in front by a padlock, *y*, or other suitable locking device. The dotted lines *n²* represent the position of the upper casing *n* when the counter is uncovered. The lower part *n'* of the casing is supported by an arm *z* on the bracket *G*. When the upper part *n* of the casing is turned back, the pinions *o p*, *o' p'* are disengaged from the rings. In order to provide for disengaging the star-wheel *K* from the counter-lever *J* so that the counter-rings can all be set at zero, as is necessary before an election, the casing *n* is provided with a lip *n³* which enters between the counter-lever *I* and the arm *j* on the bracket *G* which supports the counter-stud *g*. This lip normally holds the counter up against the star-wheel so that the pallets *b b'* engage with the teeth *l*. When the casing *n* is lifted up the lip *n³* is withdrawn from between the counter-lever and the arm *j*, and the counter-lever can be shifted laterally, (toward the

right in Fig. 15,) so as to disengage the pallets *b b'* from the star-wheel. The stud or pin *e* in the sector *H* and the pivot *h* of the counter-lever are made long enough to permit this lateral movement. In this position of the counter-lever, the casing *n* being raised, the counter-rings and star wheel are free to turn and the counter can be set, as required. The rings *m*, *m'*, *m²* are guided by lugs, screws or pins *a'*, Fig. 16, passing into circumferential grooves *e^b* in the cylinder *L*. The rings are cheaply made by punching them out in flat strips with the teeth *t*, and by subsequently bending the strips and brazing or soldering the ends together. In the case of the upper counter in any given vertical line, the upper casing *n* cannot be swung back on account of the arm *e* on the bracket *G*, Fig. 2, and consequently the front part of the case, *n⁴*, is made removable, being divided at *q'* and *c²*, and furnished with a suitable locking device at one or both these points. The lip *n²* is attached to the part of the casing *n¹*. A similar arrangement may be adopted for all the casings, or for the lower one *n²*, Fig. 6, as well as the upper one. It will thus be seen that the rings of the counter are in positive mechanical engagement with each other at all times during the operation of the machine, and that a movement of one of the rings, which might destroy the accuracy of the count, except as it receives an impulse from its neighbor, is impossible.

The tubes *F*, within which the pushes *I* slide, are screwed into openings in the plate *A*, or otherwise secured therein, as for instance by expanding them. The pushes *I* may be formed of sections of tube, having the heads *d'*, Fig. 31, inserted in the ends which are touched by the voter, and provided with the arm *f''* which acts on the sector *II* to vibrate it. Any suitable provision may be made to prevent the push from turning axially, such for instance as a pin in the push moving in a longitudinal slot in the outer tube *F*. The push also may be provided with a slot *h'*, in which the arm *i'*, Fig. 6, of the straight-ticket mechanism projects, and such arm will prevent axial movement. A handsome finish may be imparted to my machine, as seen within the voting booth, by nickeling the pushes.

The bracket *G* is attached to the tube *F*, and serves to support all the moving parts of the registering mechanism, which are thus held permanently in operative relation with each other. The bracket is fastened by screws or rivets to a projecting flange *b²*, Figs. 2 and 4, on the end of the tube *F*, and extends downward and outward in proper shape to support the parts of the counting mechanism. The arm *j* projects upward from the bracket in proper position to support the stud *g* on which the star-wheel *K* turns. The arm *i* projects outward from the bracket to carry the stud *h* on which the counter-lever *J* oscillates.

z is an arm attached to the bracket and

which carries the casing of the counter M. The upper bracket in each vertical line is also provided with an arm *c* which supports the link N of the locking-bar O, which operates to lock the counter and the sector H when fully vibrated by the push I, but to return the sector and the push to normal position when only partially actuated by the voter, as hereinafter more fully described. The inner end of the bracket G is given a shape corresponding with the curved inner surface of the flange *b*², and it is provided with a boss *e*', Figs. 4 and 20, which sustains the pivot *d* of the sector H in the proper operative relation of the sector with the arm *f*' on the push I. As indicated in Fig. 5, the surface *k* of the sector which contacts with the extremity of the arm *f*', is preferably given a curved form, so as to secure the full movement of the sector, which, in the example shown, amounts to about a quarter-revolution. It will of course be understood that the push for each candidate is provided with a sector, counter-lever and counting mechanism similar to the devices already described.

The pivoted sectors enable me to provide for interlocking the various pushes in any one vertical line, in a simple and effective way,—so that only one push in such line can be operated by any one voter,—thereby preventing voting for more than one candidate for any given office.

The construction of the interlocking mechanism will be understood from Figs. 2, 4, 6, 7, 8, 9 and 10. To each of the sectors H is attached an interlocking-rod, P, which extends upward, (in the construction shown,) and is pointed at its end, which engages with suitable interlocking devices such as the interlocking-rollers Q, arranged in a suitable case R of such a length that only one of the interlocking-rods can be inserted between the rollers at any one time.

The operation will be readily understood from Figs. 7 and 9, from which it will be seen that the rod P' having been thrust upward by the vibration of its sector, H', and its point inserted between two of the rollers Q, the series of rollers is spread out so that the outer rollers are in contact with the stops *g*' *g*² in the case R, and that none of the other rods P can be pushed between the rollers,—that is,—the push I', Fig. 7, corresponding to the rod P' having been actuated, and a vote registered on the counter for the candidate represented by push I',—no vote can be cast for any other candidate in the same vertical line,—the rollers resisting the movement of the other pushes, sectors and rods. The rods P are pivoted to the sectors in any suitable way,—such for instance as on the stud *e*, Fig. 4, which operates the counter-lever J. The rods from the various sectors are made of such a length that their points come in immediate proximity to the rollers Q. The casing R is supported from the wall A by a suitable arm *j*', Fig. 6. The casing is made

of any suitable form, capable of supporting the rollers Q at their ends, and of permitting the interlocking-rods to pass between the rollers. In the casing shown, it consists of a lower channel-iron *k*², Fig. 10, and an upper channel iron *k*',—suitable openings being made in the horizontal portions of these irons for the guidance of the interlocking rods while passing through the openings. The blocks or stops *g*' *g*² are secured in the proper positions in the channels by the screws *n*⁶. This construction permits of easy access to the rollers,—one of the channel irons being made in sections, *s*', extending from one screw *n*⁶ to the next, as indicated in Fig. 8, in which the division line between the sections is represented at *n*'. By taking off the section *s*' of the channel-iron *k*', one or more of the interlocking rollers Q may be removed, and a block, such as represented at Q' or Q², Fig. 12, may be substituted, which block or blocks will entirely prevent the movement of one or more of the rods P, so that one or more of the pushes I may be rendered inoperative. This arrangement adapts my machine to the case, such as occasionally happens, where one or more of the political parties fails to nominate a candidate for a given office. Thus, suppose that out of five parties, one does not present a nominee for some office. In such a case, the series of rollers Q corresponding to the line of pushes for such office is reduced in number and the space filled up with a block similar to that shown in Fig. 12, so that only four of the pushes in such line can be actuated by a voter,—the placard for the missing candidate being of course omitted. As the sectors H vibrate, the lower ends of the interlocking-rods P swing outward, but the openings in the case R are made wide enough to permit such motion, and the rods may be round in section and conical at their points, if preferred. The longer rods may be guided in a slot in an arm *j*², Figs. 6 and 7 attached to the plate A, if requisite. The screws *n*⁶ pass through the blocks *g*' *g*² and secure them in place and the channel-irons together. The interlocking-rods P are bent or offset, so as to pass by each other.

It will be understood that each vertical line of pushes is provided with the interlocking mechanism, and that provision is thus made for preventing the actuation of more than one push in any one vertical line, including the device for the irregular vote hereinafter described. As the rollers Q are free to revolve in the case, the interlocking-rods pass between them with only a slight friction, and the operation of the interlocking mechanism is smooth and easy. In a modification, the rods may be pivoted directly on the counter-lever, and in a modified construction, the rollers Q may be located in any desired position relative to the line of pushes,—the rods being jointed or bell-cranks or other levers employed, as may be desired. In all cases, the rollers will be one more than the number of

rods, and the space between the stops $g' g^2$ will be greater than the sum of the diameters of the rollers by the thickness of one of the rods.

5 When the voter leaves the booth, the apparatus is reset in its normal position, by the action of the moving resetting-bar X, Figs. 1, 6, 7, 22, 28, 29 and 30, which descends and forces the interlocking rods down, restoring
10 the sectors and pushes to their original positions, so that the machine is ready for the next voter. The requisite movement of the resetting bar X is secured from the swinging of a door through which the voter passes on
15 leaving the booth.

Any suitable mechanism may be employed for enabling the voter to cast an irregular ballot. The row of irregular balloting devices, B^5 , Fig. 1, may consist of simple orifices
20 in the plate through which a prepared ballot is deposited,—in a box or other receptacle,—such orifice being protected or covered by a door which is interlocked with the pushes in
25 the same vertical line, in any suitable manner. A door which may be employed for such purpose is represented in connection with the multicandidate group C, Figs. 21 and 22,
30 hereinafter described,—said door being pivoted to the plate A to cover the ballot-orifice, and provided with an arm extending through the plate and pivoted to an interlocking-rod engaging with the same series of
35 voters can deposit a prepared ballot but cannot vote by any of the pushes for any other candidate for the same office.

In another form of irregular-voting mechanism the pushes are provided with orifices
40 in which the ballot is inserted, and, on forcing the push inward, the ballot drops through an opening into a suitable box. In order however to comply with the laws in some of the states, I prefer to employ the irregular-voting-mechanism illustrated in Figs. 23 to 27
45 inclusive, in which the ballot is prepared and placed in a suitable holder, and said holder, on being inserted through an orifice in the plate, actuates the interlocking mechanism,
50 and is discharged into a suitable box by the action of the resetting-bar.

The ballot-holder is represented at C' in Figs. 23, 24, 25, 26 and 27. It consists of a suitable metallic case, open at one side or end
55 for the insertion of the folded ballot, and formed in any suitable way. J' is a channeled or tubular bar secured to the rear side of the plate A and having a passage through it of sufficient size to admit the ballot-holder, and
60 carrying at its outer end the pivoted sector II, which is similar to the sectors already described and has the interlocking-rod P pivoted to it. The sector H is pivoted at d^2 on a pin inserted in a boss f^2 on the tube
65 J' . When the holder is fully inserted in the tube, its end forces the sector H from the position indicated by the dotted lines in Fig.

23, to the position shown by the full lines H^2 , raising the interlocking-rod P and causing its pointed end to enter between the
70 rollers Q, Fig. 9, as already described,—in which case all the pushes in the same vertical line with the irregular-balloting device are locked, so that they cannot be actuated.
75 The tube J' is provided with a hinged bottom-plate K' , which is swung downward by the movement of a door as the voter leaves the booth, so as to discharge the ballot-holder C' into the tube L' , through which it slides
80 into a suitable receiver or box, M' , Fig. 1. The plate K' is pivoted to the sides of the bar J' at g^3 , Fig. 23, near the plate A. The plate K' is connected so as to be vibrated by the resetting bar X by the rod Z, Figs. 23, 24,
85 and 25. An arm h^2 on the side of the plate K' extends outward and affords a point of attachment for the rod Z. A curved plate (or two rods or wires $S' S^2$) extends from the end of the bar J' to the tube L' , and prevents the
90 ballot-holder from slipping off of the plate K' while it is swinging downward to the position represented by K' , Fig. 23. It will be observed that when the holder has been fully inserted in the tube J' , its end falls below and engages with a shoulder o^3 , Fig. 23, on
95 the plate A, and that, as the plate K' swings, this end of the holder will be guided by the sides of the bar J' . At the other end the plate K' is provided with the lugs or hooks
100 $q^2 q^3$, which prevent any lateral displacement of the holder, but permit it to slide down through them into the tube L' .

p^3 is a foot or enlargement by which the bar J' is secured to the plate A. The end of the bar J' is recessed, to permit the movement of the sector H and the interlocking-rod P. The orifice y' in the plate A through which the ballot-holder is inserted may be protected by a door, U' , which, for symmetry of appearance may be made to correspond
110 with the doors on the multi-candidate group C. These doors U' are pivoted to the plate A in front of the orifices y' , and are counterweighted, as indicated at b^3 , Fig. 23, so that they close automatically, and must be opened
115 by the voter before he can insert his ballot.

I provide the voting booth with a small room or chamber, G' , Fig. 30, into which the voter may retire to prepare his ballot,—which may be either written or pasted or printed.
120 On being admitted to the voting-booth, the voter inserts his ballot (in a holder) into the orifice intended for the candidate for the particular office, and on leaving the booth, such ballot is deposited in the proper box. The
125 splitting of electoral tickets for President is easily accomplished by the improvement described. The tubes or delivery spouts L' may be inclined so as to pass by the pushes of the questions-voting mechanism.
130

It is desirable to prevent a weak or incomplete movement of any of the pushes or ballot-holders from causing the interlocking, and this I accomplish in a simple and effective way

by means of the movable counterweighted locking-bar O, Figs. 2, 4, 6, 7, 23, 24 and 25. The locking-bar extends vertically along an entire vertical line of pushes, and the irregular voting device, and is normally in contact with all the sectors in any such line. See Figs. 2, 4, 23 and 25. The locking-bar O is supported at its upper and lower ends by the pivoted counterweighted links $N N'$, which permit it to move bodily outward from the plate A when any one of the sectors is vibrated, to the positions shown in dotted lines, Figs. 2 and 23. When one of the sectors is vibrated, it presses against the locking-bar O and causes it to move outward from the plate A. Each sector is provided with a lip s^2 , (see Fig. 5,) which engages with a catch t^2 on the locking-bar, when the full movement has been given the push or holder. The links $N N'$ are counterweighted by the weights q^2 , so that the bar O has a constant and invariable tendency to return toward the plate, and consequently, in case a weak or incomplete movement is given to any of the pushes, or the holder, by the voter, the push or holder is returned to the normal position, and the voter is thereby notified that he has not voted. Each voter is instructed before entering the booth, that he must push in the pushes or the holders as far as they will go, and so that they do not return, and that his vote will not count unless he follows these instructions. When the push or the holder has been shoved home, the lip s^2 , on the sector will engage with the corresponding catch t^2 on the locking bar, and the sector will be held in the position indicated at H' , Figs. 2 and 6, and at H^2 , Fig. 23,—the pushes and holder being interlocked, and the counter having been moved one digit. The parts will remain in this position, until the resetting-bar is moved downward by the voter as he passes through the door on his exit from the booth, when the interlocking rods will be pushed downward, the lip s^2 will be disengaged from the catch t^2 , and the parts will be restored to their normal condition. It will be understood that, in the meantime, the push may be moved backward and forward indefinitely, if the ingenuity of the voter can find a way to do this, without again operating the counting-mechanism. The link N is pivoted at e^2 , Figs. 2 and 6, on an arm c arising from the bracket G of the upper push and the link N' is pivoted at e^4 on an arm c^3 on the bracket G of the lower push or irregular voting device, Fig. 6. These pivots may if preferred, be carried by suitable arms extending outward from the plate A. The lips s^2 and catches t^2 are beveled, so that, although the sectors are held firmly by the catches, they are readily disengaged from the locking bar by the operation of the resetting mechanism. The links $N N'$ are connected with the weights q^2 by the arms v^2 . In order to secure a parallel movement of the locking-bar O, the arms v^2 or the weights q^2 may be connected together by a rod w^2 , Fig. 6.

The construction of the mechanism for voting on questions will be understood from Figs. 1, 6, 7 and 11. The pushes $I^2 I^3$ are arranged in pairs, $D D' D^2$,—each pair being designed to register a vote in favor of or against any proposed measure. The pushes are similar to those already described, being supported in a tube F' inserted in the plate A, and provided with pivoted sectors, counter-levers and counter-mechanism in the manner already mentioned. The pushes $I^2 I^3$ are interlocked against each other, so that only one of them can be actuated by any single voter, by means of the rods $P^3 P^4$ and the interlocking device represented in Figs. 7 and 11. The rods $P^3 P^4$ are offset and carried nearer the plate A than the rods P of the upper pushes, between the adjacent lines of push-carrying tubes, as represented in the rear view, Fig. 7. The interlocking rollers Q^3 , Fig. 11, are supported in a case R' , attached to plate A by an arm j^3 . The case R' may be similar in construction to the case R, Figs. 8 and 9, already described. Between the rollers $Q^3 Q^3$ is placed a sliding space-bar v' . In order to afford a suitable guide for the upper ends of the interlocking rods $P^3 P^4$, they are provided at their upper ends with the thinned tongues t' Fig. 11, which remain between the rollers when the pushes are in their normal positions. The length of the case R' and bar v' is made such that only one of the rods $P^3 P^4$ can be forced between the rollers, so that a voter can only actuate one of the pushes $I^2 I^3$. The sector of the questions-push is provided with the locking-bar O^3 , Fig. 6, arranged to operate in a manner similar to the locking-bar already described. The locking-bar O^3 is carried by the links $N^3 N^4$ pivoted on the arms $c^4 c^5$ on the bracket G^2 attached to the tube F' . The locking bar O^3 is counterweighted by the weights $q^3 q^4$, which may be connected together by the rod w^3 to secure parallel movement of the locking-bar. The bar O^3 operates to return the push I^2 in case of a weak or incomplete movement, and to lock its sector upon a complete movement. It is obvious that the interlocking rods $P^3 P^4$ of the questions pushes might be carried downward, but, in order to bring them in the proper relation with the resetting-bar X, I prefer the construction shown.

The mechanism by which the voter is enabled to vote a straight-ticket consists of a rock-shaft S arranged parallel to one of the rows of pushes and provided with arms i' which engage with all the pushes in the row, so that they may all be actuated by a partial rotation of the rock-shaft effected by the lever E. The shaft S is supported from the wall A by suitable arms or brackets t^2 . The arms i' are secured to the rock-shaft in any suitable manner. They project through slotted openings in the push-carrying tubes F, and into slots in the pushes I. These slots are elongated so as to permit the inward movement of the pushes without moving the rock-

shaft. At one end the rock-shaft is either directly connected with the lever E, or an intermediate connecting device is employed, such as the mutilated pinions T T', Figs. 2 and 4, by which the shaft is operated from the lever. U, Fig. 4, is a socket, secured to the plate A, and which supports the pivot w^3 on which the lever E swings. The lever E extends out in front of the plate, into a convenient position for the voter to operate it. In order to avoid an opening in the plate the lever is provided with the segmental plate x' , Fig. 2,—the curved edges of which fill the orifice through the plate in any position of the lever.

It will be understood that each of the rows of pushes, (except the devices for the irregular ballot,) is provided with a rock-shaft, push-actuating arms and an operating lever, as described. It will also be understood that the actuation of the pushes in any one row, by means of the straight ticket lever, locks all the remaining pushes in each vertical line, through the interlocking mechanism already described, so that none of the candidates out of said row can be voted for. The irregular row is also interlocked at the same time. By means of the straight-ticket lever, the voter is enabled to cast all his votes for his party in the simplest and most expeditious manner possible. The multicandidate group or groups C may be arranged to be worked independently of the straight-ticket mechanism, if preferred.

When there are two or more candidates for the same office, nominated by the same party, such as constables, coroners, inspectors of election, &c., I employ the mechanism shown in Figs. 1, 21, and 22, which differs from the interlocking devices already described, in order to permit the voter, if he desires, to vote for two or more candidates in the same vertical line. In this case, the pushes are covered by doors V V, each of which requires to be opened before its corresponding push can be actuated, and which doors are interlocked against each other by the rods P⁵ and the series of interlocking devices or rollers Q⁵,—the arrangement being such that only a given number of the doors can be opened, after which the remaining doors are locked. Thus, for instance, suppose, as in the example illustrated, for an extreme case, there are five political parties, each of which is permitted to nominate five candidates for any such office, and then, in order to provide for voting for five irregular candidates also, there will be thirty candidates in the whole group. If the voter desires to vote for all of the candidates of his party, he simply uses the straight ticket lever,—all the pushes I⁴ of this group or groups, being operated by the rock-shafts S as hereinbefore described. The doors of all the other parties, and the irregulars, are at the same time locked fast so that they cannot be opened, by the rock-shaft. If however, the voter desires to select from among all the

candidates of all the parties, he opens the doors (which are provided with name-cards a^2) corresponding to the candidates he desires to vote for, and actuates the pushes exposed by opening the doors,—each push so actuated operating a counter similar to those already described. The pushes of this multicandidate group are not interlocked,—the rods C² serving merely to return the pushes to normal position, or to reset them, when the voter leaves the booth. The doors V are hinged so that their upper ends swing outward and downward. See Fig. 22. The doors are provided with arms w' , to which are pivoted the lower ends of the rods P⁵, the upper ends of which engage with the series of rollers Q⁵, so arranged that after five of the doors, (in the case specified) have been opened, the remainder are locked fast, and cannot be opened,—thereby preventing access to the pushes concealed by them. This arrangement enables the voter to select from among all the candidates, those that he prefers, and to cast a vote for them. Thus he may select one or more candidates in any of the rows, or one in each row, or one or more in any of the vertical lines, or one in each of such lines. For instance he may vote for one candidate in the upper row, two in the second row, one in the third row, and one person in the irregular row, as indicated by the open doors in Figs. 21 and 22; or he may vote for any or all of the irregular candidates,—in all selections the number of votes which he can cast being limited to five. The doors are pivoted to the plate A in any suitable way, and they are provided with knobs or handles z' by which they may be opened. They may also be provided with spring-catches for holding them closed or the arms w' may be counterweighted. The rollers Q⁵ are supported in a suitable frame R⁴ the length of which is such that, (in the case stated) only five of the rods P⁵ can be inserted between the rollers. The frame R⁴ is provided with the stops $g^4 g^5$ placed at the proper distance apart to produce this result. In Fig. 21, the five interlocking-rods corresponding to the open doors, are represented as inserted between the rollers, which then occupy the full space between the stops $g^4 g^5$. Two of the rods may pass between the same rollers, if requisite, or the rods may be spread outward to engage between different rollers. The rollers may be solid or hollow. The frame R⁴ for the interlocking-rollers is constructed in the same manner as already described, and it may be supported from the plate A in any suitable manner. The doors V are pivoted on the rods or pins x^2 , inserted in lugs on the plate, or preferably on a perforated plate Z' attached to the wall, and carrying the ribs o^5 and the hoods r^5 , which protect the pushes from being moved, until the doors have been opened sufficiently to insert their corresponding interlocking-rods between the rollers. At the same time, the interlocking-rods are locked so that the doors

cannot be closed, by the device represented in Figs. 22 and 32. Each of the rods P^5 is provided with a notch s^4 , Fig. 32, which engages with the casing k^4 of the frame R^4 ,—the upper end of the rod being given a tendency away from the plate A by the hinged plate U^2 , which normally rests on the upper ends of the rods, as shown by the full lines in Fig. 32, but which swings upward, as indicated by the dotted lines, when one of the rods rises, and causes the notch s^4 to engage over the upper part k^4 of the frame R^4 . In this position of the rod, its door is locked open so that it cannot be closed. The arrangement is such that the locking of the notch s^4 over the frame takes place when the door is just clearing the hood as it is opened. Consequently the push I^4 is inaccessible to the voter, even by wires or other suitable devices until the door has been opened, its interlocking rod inserted between the interlocking rollers, and locked in position against shutting the door. This arrangement prevents a voter from actuating more than the permitted number of pushes in the multicandidate group. The frame R^4 may be constructed as already described, of upper and lower channel irons k^4 k^5 , Fig. 32, and provision may be made for reducing the number of candidates in the group, by substituting blocks for some of the interlocking rollers, in like manner to that already mentioned. The unlocking of the rods P^5 from the frame R^4 and the closing of the doors are accomplished by the descent of the resetting-bar X, which, when it first moves downward, bears against an inclined surface f^3 on the side of the rod, and forces it toward the plate A, disengaging the notch s^4 from the frame, after which the descent of the rod and the closing of the door are accomplished by the continued downward movement of the resetting-bar, which comes in contact with a projection v^3 on the rod. The plate U^2 is hinged to the wall A at w^2 , and acts by gravity on the rods. The frame R^4 is supported by the arm j^4 , or in any other suitable way. The tubes F^3 of the pushes I^4 are provided with brackets G, which carry sectors H, and counter-levers and counting-mechanisms similar to those already described. The irregular-balloting devices J^2 of the multicandidate group are also constructed in the same way as those previously mentioned, and arranged to deliver the ballot-holder into the tubes L^1 and boxes M^1 . The pushes I^4 are provided with name-cards on their ends, visible when the doors are open. In case two or more multicandidate groups are employed in my improved voting machine, the pins x^3 may extend horizontally through the doors of all the groups. The sectors of the pushes I^4 and of the irregular-balloting device J^2 may be provided with the locking bar O, as already described. On their upper ends, the return-rods C^2 , Fig. 22, may be provided with notches and a locking-

plate,—the construction being similar to that shown in Fig. 32, so that each of the rods is locked as it rises,—the locking bar being omitted; or the locking bar O may be provided with pivoted catches, operating by gravity, and arranged to engage with the lips s^2 on the sectors. The return-rods C^2 are forced downward by the resetting bar X, which comes against lips or projections y^2 on the rods. The upper ends of the return-rods C^2 are supported in a perforated plate, D^3 , Figs. 13, 14 and 22, sustained by the arm j^4 ,—which permits the movements of the rods through it while holding them in the proper positions.

In order to provide for the locking of all the doors of the multicandidate group by the operation of the straight-ticket rock-shaft, I employ the device shown in Figs. 21 and 33. The rock-shaft inserts the enlarged end z^3 of the rod W' between the interlocking rollers Q^3 , so as to take up all the space in the frame R^4 ,—after which none of the doors V can be opened. The rod W' is arranged to move lengthwise, in suitable guides on the plate A,—its upper end z^3 being beveled and made of a width equal to the thickness of five of the rods P^5 ,—in case there are five nominees by one political party in the multicandidate group. The enlarged end z^3 is made removable from the rod, and narrower ones may be substituted in case there are a less number of nominees. The rod W' is provided with a number of slots, d^4 , Fig. 32, in which pins a^3 , Fig. 33, on the arms z^4 attached to the rock-shafts S engage. These slots permit the rod to be raised by any one of the rock-shafts independently of the others.

The construction and operation of the resetting mechanism, by which the voter returns the voting-mechanism to its normal position as he passes out of the booth, will be understood from Figs. 28, 29 and 30.

O^2 is the entrance door, through which the qualified voter is admitted to the booth by the proper election officer.

R^2 is a turnstile, of any ordinary construction, provided with a ratchet-mechanism of any suitable sort, which permits it to turn in one direction only, as indicated by the arrow in Fig. 30. A ratchet x^3 is applied to one end of the turnstile, and a weighted pawl v^4 engages with the ratchet, so as to prevent any reverse movement of the turnstile. After passing through the turnstile, the voter encounters a swinging arm or door Y' in the passageway Z^3 leading out of the booth,—the movement of which is transmitted to the resetting-bar by the lever L^2 . At one end the lever L^2 is connected with the bar X by the link c^6 , and at the other it is connected by link f^3 with the curved bent arm T^2 , which is pivoted to the wall of the booth at z^2 , and passes through a slot or between rollers m^5 n^7 on the door. As the door swings, the arm T^2 is moved up or down and this movement is imparted to the resetting bar by the links and lever shown. The motions of the various

parts are indicated by the full and dotted lines in the figures. When the voter opens the door to pass through it, the arm T^2 is pushed upward, in consequence of its curved form, and the bar X is depressed,—such motion of the latter forcing down the interlocking-rods, and restoring the sectors, pushes and doors to their normal position,—so that the booth is ready for the next voter. The arm T^2 is given such a shape that its upward movement is completed before the door has been fully opened, so that not even a thin man can squeeze through without operating the resetting mechanism. The lever L^2 is pivoted to a bracket F^2 attached to the ceiling of the booth. The lever is protected inside the booth by a false ceiling e^5 . The resetting bar X may be counterbalanced by a weight γ^4 on the lever L^2 , and the door Y' may be weighted in any suitable way so as to close automatically.

Z^3 is an exit door.

The rods Z which operate the irregular-balloting-devices, are connected at their upper ends with the resetting-bar X , by being pivoted to eyes h^4 thereon, or in any other suitable way. When the door Y' is opened, as the voter passes out of the booth, the resetting bar X descends, and this motion, transmitted through rod Z , see Fig. 6, swings the lower plate K' to the position K^2 , Fig. 23, so that the ballot-holder is delivered into the tube L' . When the door Y' closes, the resetting bar rises, and the plate K' is restored to its normal position. This arrangement is the same for all the irregular-balloting devices, including those in the multicandidate group or groups.

The resetting bar X slides up and down in any suitable ways or guides on the plate A . In the arrangement shown, the bar X is provided with the pins l^5, l^6 Figs. 22 and 28, which travel in the guide-ways s^5, s^6 , which are attached to the plate by suitable arms. The resetting bar X may be provided with notches h^5 , Fig. 28, which fit over the arms j^2 which support the frame of the interlocking rollers. See Fig. 6. The resetting bar is provided, opposite the multicandidate group with a projecting lip i^5 which operates the interlocking-rods of the doors.

It will of course be understood that many changes may be made in the construction or arrangement of my improved voting-machine, without departure from the principles thereof, the essential feature being the securing of absolute certainty of registry by the maintenance at all times during the operation of the machine, of a positive mechanical engagement between the interlocked pushes and the counting mechanism. For instance, the movable parts which actuate the counting mechanism may be arranged to be pulled out by the voter, instead of being pushed in. The irregular-balloting devices, or the multicandidate group may be omitted. Instead of the straight-ticket levers shown, a push or pull

may be arranged to actuate all the counting mechanisms devoted to any one political party. Ballots not in holders will not be counted. A supply of ballot-holders will be provided by the election officials. One of the principal advantages of my machine, in addition to the absolute certainty of its operation, is that the printing of tickets, and the consequent trouble and expense, may be entirely dispensed with, each voter who desires to vote for any person not a regular nominee being required to prepare his own ballot. Suitable blanks may be furnished by the election officials. A series of gravity catches may be substituted for the locking-bar shown. The mechanism for resetting the apparatus as the voter leaves the booth, may be constructed in various ways different from that herein shown.

The construction of the doors of the multicandidate group is shown in Fig. 35. The door is double, the two plates forming it being secured together by a lip on one engaging over the edge of the other and by the pin or rod which passes through the eyes. The outer plate is perforated so as to display a name-card protected by a slip of glass.

The racks or frames for holding the name-cards a may be conveniently formed in one piece extending along all the pushes, (except those of the multicandidate group,) and secured at its ends by staples, a padlock or other suitable device. In case it becomes necessary to cover any of the pushes, these frames may be provided with suitable plates for this purpose.

In this specification the word "series" is understood to mean two or more similar parts and "simultaneous" refers to the operation of the counting mechanisms or balloting devices by any one individual voter.

I claim—

1. The combination, in a voting-machine, of a row of movable parts adapted to be actuated by a voter, a corresponding series of counting-mechanisms operated by the movable parts, positive counter-actuating mechanisms between each movable part and its counter maintaining constant mechanical engagement with the counter, whereby it can be rotated only by the movable part, a series of locking devices for retaining the counters in position, a suitable support, and suitable straight-ticket mechanism adapted to actuate the counting mechanisms simultaneously, substantially as described.

2. The combination, in a voting-machine, of a row of movable parts adapted to be actuated by a voter, a corresponding series of counting-mechanisms operated by the movable parts, positive counter-actuating mechanisms between each movable part and its counter, comprising a series of pivoted sectors and of vibrating counter-levers, the latter maintaining constant mechanical engagement with the counter, whereby it can be rotated only by the movable part, a series of locking devices for retaining the counters in position,

a suitable support, and suitable straight-ticket mechanism adapted to actuate the counting mechanisms simultaneously, substantially as described.

5 3. The combination, in a voting machine, of two or more rows of movable parts adapted to be actuated by a voter, each row representing candidates of one political party, interlocking mechanisms between the corresponding parts in each row which represent
10 candidates for the same office, two or more series of counting mechanisms operated by the movable parts, corresponding series of positive counter-actuating mechanisms between the movable parts and the counters
15 maintaining constant mechanical engagement with the counters, a suitable support, and two or more straight-ticket voting mechanisms carried by the support and adapted to actuate all the counting mechanisms in
20 any row simultaneously, while permitting their independent movement, substantially as described.

4. The combination, in a voting machine, of
25 two or more rows of movable parts adapted to be actuated by a voter, each row representing candidates of one political party, interlocking mechanisms between the corresponding parts in each row which represent
30 candidates for the same office, two or more series of counting mechanisms operated by the movable parts, corresponding series of positive counter-actuating mechanisms between the movable parts and the counters
35 maintaining constant mechanical engagement with the counters, a suitable support, and two or more rock-shafts carried by the support and provided with a series of arms whereby all the counting mechanisms in any
40 one row may be operated simultaneously, while their independent movement is permitted, substantially as described.

5. The combination, in a voting machine of a row of movable parts representing candidates of a political party, a corresponding
45 row of counting-mechanisms operated by the movable parts, a corresponding row of irregular-balloting-devices, comprising receivers for prepared ballots and mechanism for depositing
50 said ballots therein, and interlocking mechanism between the movable part and the mechanism of the irregular-balloting-device which represent a nominee for the same
55 office, said interlocking-mechanism being arranged to be operated by the movable part, or upon the insertion of the ballot, substantially as described.

6. The combination, in a voting machine, of a row of movable parts representing candidates of a political party, a corresponding
60 series of counting-mechanisms operated by the movable parts, a straight-ticket mechanism whereby the said row of counting mechanisms may be simultaneously operated, a
65 corresponding row of irregular-balloting-devices, comprising receivers for prepared ballots and mechanism for depositing said bal-

lots therein, and interlocking mechanism between the movable part and the mechanism of the irregular balloting-device which represent a nominee for the same office,—the
70 straight ticket mechanism being arranged to lock the irregular balloting devices from operation and the interlocking mechanism being arranged to be operated by the movable
75 part, or upon the insertion of the ballot, substantially as described.

7. The combination, in a voting machine, of a row of movable parts adapted to be actuated by a voter, a corresponding series of
80 counting-mechanisms operated by the movable parts, a multicandidate group comprising a row of movable parts provided with protecting doors and counting mechanisms, and straight ticket mechanism for simultaneously operating all the movable parts in
85 both groups, substantially as described.

8. The combination, in a voting-machine, of two or more rows of movable parts, adapted to be actuated by a voter,—each row representing candidates of a political party,—two
90 or more corresponding series of counting mechanisms operated by the movable parts, interlocking devices between the parts in the different rows which represent a nominee for
95 the same office, a multicandidate group comprising two or more rows of movable parts, provided with protecting doors and counting mechanisms, and two or more independent straight ticket mechanisms for simultaneously
100 operating all the movable parts which represent candidates nominated by one of the political parties, substantially as described.

9. The combination, in a voting machine, of a row of movable parts representing candidates of a political party, a corresponding
105 row of counting-mechanisms operated by the movable parts, a corresponding row of irregular balloting-devices comprising a movable interlocked part arranged to be moved by
110 the insertion of a suitable ballot-holder, a ballot-receiver, and interlocking-mechanism whereby the simultaneous operation of one of the movable parts and the corresponding irregular-balloting-device is prevented, substantially
115 as described.

10. The combination, in a voting-machine of a movable slide adapted to be actuated by a voter, the pivoted sector arranged to be moved positively in one direction only by the
120 slide, the toothed wheel of the counting mechanism, and the oscillating counter-lever operated by the sector and provided with inclined pallets engaging positively with the teeth of the wheel on opposite sides thereof,
125 substantially as described.

11. The combination, in a voting machine, of a movable slide adapted to be actuated by a voter, the counting mechanism provided with the toothed wheel, the oscillating counter-lever
130 provided with inclined pallets engaging continuously with the teeth of the wheel on opposite sides thereof, and operated in one direction by the slide, and the movable resetting

device whereby the slide and counter-lever are restored to normal position, substantially as described.

12. The combination, in a voting-machine, of a movable slide adapted to be actuated by a voter, the pivoted sector arranged to be operated by the slide, the counting mechanism provided with the toothed wheel, the slotted oscillating counter-lever, operated by a pin on the sector engaging in the slot, and provided with inclined pallets engaging positively with the teeth of the wheel on opposite sides thereof, substantially as described.

13. The combination, in a voting-machine, of two or more movable slides adapted to be actuated by a voter, corresponding pivoted sectors, the toothed-wheels of the counting-mechanisms, the oscillating counter-levers, and two or more pointed interlocking-rods, operatively connected with the sectors, and the interlocking devices supported in a suitable frame, substantially as described.

14. The combination, in a voting machine, of a suitable supporting plate, a tube attached thereto, the movable slide arranged in the tube, the pivoted sector, the counting mechanism provided with the toothed wheel, the oscillating counter-lever, and a bracket carried by the tube and arranged to support the counting mechanism and the counter-lever, substantially as described.

15. The combination in a voting machine of two or more rows of movable slides in the multicandidate group, each slide provided with suitable counting mechanism and positive counter-actuating mechanism, pivoted protecting doors for each slide, interlocking mechanism between the doors arranged to permit the simultaneous actuation of a limited number of the slides, locking mechanism for preventing the closing of the doors, and suitable hoods around the doors arranged to prevent the actuation of the slides until the doors are locked open, substantially as set forth.

16. The combination, in a voting-machine of the plate A, the push I, counting mechanism M provided with toothed wheel K, the counter lever J provided with pallets b b' adapted to engage positively with the teeth of the wheel on opposite sides thereof, the pivoted sector H, provided with lip s^2 , and the movable locking bar O, having catch t^2 adapted to engage with the sector, substantially as described.

17. The combination, in a voting machine, of the plate A, the tube F, the push I arranged to slide in the tube, the pivoted sector H, sector locking device O, and a suitable counting mechanism operated by the sector, substantially as described.

18. The combination, with the plate A, of a series of two or more supports F, each provided with a slide movable therein, a pivoted sector operated by the slide, a counter-lever operated by the sector, a suitable counting-mechanism operated by the counter-lever and interlocking mechanism which pre-

vents the simultaneous actuation of two or more of the slides, substantially as described.

19. The combination, in a voting machine, of a row of movable parts adapted to be actuated by a voter and representing the candidates of a political party, each movable part being provided with a suitable counting mechanism, and mechanism for operating the counter from the movable part while maintaining positive mechanical engagement therewith, a corresponding row of irregular balloting devices each comprising a receiver for prepared ballots and mechanism for depositing said ballots therein, interlocking devices whereby the simultaneous operation of corresponding members of the regular-voting and irregular-balloting devices are prevented, a series of movable parts in the multicandidate group, adapted to be actuated by a voter, each provided with counting mechanisms and positively acting operating mechanism, a corresponding series of irregular-balloting devices in the multicandidate group, movable doors protecting both the regular-voting devices and the irregular-balloting devices in the multicandidate group, and interlocking mechanism arranged to permit voting for a limited number of candidates either regular or irregular, or both, in the multicandidate group, substantially as described.

20. The combination, with the plate A, of the support F, provided with a slide, sector, counter-lever and counting-mechanism, and an irregular-balloting-device, provided with a sector, and the movable locking bar O, arranged to act on either sector, substantially as described.

21. The combination, with the plate A, of the support F, provided with a slide, sector, counter-lever and counting mechanism, an irregular balloting device, as J' , adapted to be operated by the insertion of a ballot holder provided with a sector, the movable locking bar O, and interlocking rods arranged to engage with the interlocking-rollers Q, substantially as described.

22. The combination, in a voting-machine, of the questions-slides I^2 I^3 , each provided with a pivoted sector, a counting mechanism and counter-lever adapted to maintain constant mechanical engagement with the counter, a sector-locking device, and the interlocking rods P^3 P^4 and the interlocking devices Q^3 , substantially as described.

23. The combination in a voting machine, of two or more rows of movable slides in the multicandidate group, each slide provided with suitable counting mechanism and positive counter-actuating mechanism, pivoted doors for each slide, interlocking mechanism between the doors arranged to permit the simultaneous actuation of a limited number of the slides, locking mechanism for preventing the closing of the doors, and suitable hoods around the doors arranged to prevent the actuation of the slides until the doors are locked open, and the movable resetting bar,

adapted to unlock the opened doors, to close them and restore the actuated slides to normal position, substantially as set forth.

24. The combination, in a voting machine, of a movable slide adapted to be actuated by a voter, and provided with a pivoted sector and suitable counting mechanism operated thereby, the irregular-balloting-device comprising a receptacle for a ballot-holder provided with a sector arranged to be operated by the holder, means for discharging the ballot-holder from the receptacle, and suitable interlocking-mechanism between the slide and the balloting-device, whereby the actuation of one prevents that of the other, substantially as described.

25. The combination, in a voting-machine, of the ballot holder receptacle J', the sector H pivoted to the inner end of the receptacle and adapted to be actuated by the insertion of the ballot-holder, the movable bottom-plate K' attached to the receptacle and arranged to discharge the ballot holder therefrom, the resetting device X and connection Z, substantially as described.

26. The combination, in a voting-machine, of the ballot-holder receptacle J', the movable bottom-plate K' attached to the receptacle and arranged to discharge the ballot-holder therefrom, the resetting device X, guide S', and receiver M', substantially as described.

27. The combination, in a voting machine, of the slide I, the movable sector H operated by the slide, suitable counting-mechanism provided with toothed wheel K, the counter-lever J operated by the sector and arranged to maintain positive mechanical connection with the toothed wheel during the operation of the machine, and means for shifting the lever and toothed wheel laterally relative to each other, substantially as described.

28. The combination, in a voting machine, of two or more interlocking voting mechanisms, each comprising a movable slide adapted to be operated by a voter, a counting-mechanism containing a toothed wheel and two or more figured rotatory registering devices in positive mechanical engagement with each other, a counter lever actuated from the slide and adapted to impart an intermittent rotary movement to the wheel while maintaining positive mechanical engagement therewith, means for shifting the counter-lever and toothed wheel laterally relatively to each other to permit the restoring of the counting mechanism to zero position, and means for returning the counter lever and slide to normal position after a voting operation without action on the counting mechanism, substantially as described.

29. The combination, in a voting machine, of two or more interlocking voting mechanisms, each comprising a movable slide adapted to be operated by a voter, a counter-mechanism containing a toothed wheel and two or more figured rotatory registering devices in posi-

tive mechanical engagement with each other, a counter lever actuated from the slide and adapted to impart an intermittent rotary movement to the wheel while maintaining positive mechanical engagement therewith, means for shifting the counter-lever and toothed wheel laterally relatively to each other, a device for disconnecting the mechanical engagement between the rotatory registering devices, whereby the restoration of the counting mechanism to zero position is permitted, and means for restoring the counter lever and slide to normal position after a voting operation without affecting the counting mechanism, substantially as described.

30. The combination, in a voting-machine, of a series of two or more movable regular-voting slides of the multicandidate group, each provided with a counting mechanism, a corresponding series of irregular balloting devices in the multicandidate group, the pivoted protecting doors for the two series, the notched interlocking rods connected to the doors, the movable plate which prevents the return of the rods, and suitable interlocking devices, substantially as described.

31. The combination in a voting machine of two or more series of movable parts in the multicandidate group, each series representing candidates of a political party, and each part being provided with a suitable protecting door, the interlocking rods pivoted to the doors, and the interlocking devices supported in a suitable frame adapted to permit the actuation of two or more of the movable parts anywhere in the whole group, substantially as described.

32. The combination, in a voting-machine, of the pushes of the multicandidate group, the pivoted protecting doors for the said pushes, the notched interlocking-rods connected to the doors, the interlocking-blocks or rollers, and a movable bar or plate adapted to engage the notches of the rods with a stationary part of the machine, substantially as described.

33. The combination, in a voting-machine, with the pushes of the multicandidate group, arranged in rows each of which comprises all the candidates of any one political party for a given office, of the rock-shaft provided with arms arranged to operate all the pushes in any one row simultaneously, the protecting doors for the pushes, the interlocking-rods connected to the doors, the interlocking blocks or rollers, and the widened interlocking-rod operated by the rock-shaft, substantially as described.

34. The combination, in a voting machine, with two or more rows of pushes in the multicandidate group, each row comprising all the candidates of one of the political parties for a given office, the protecting doors for the pushes, the interlocking rods connected to the doors, the interlocking blocks or rollers, two or more rock-shafts, one for each row of pushes, adapted to actuate all the pushes in

any one row simultaneously, and the slotted interlocking-rod of increased thickness, substantially as described.

35. The combination, in a voting-machine
 5 of a row of movable parts adapted to be actuated by a voter, and representing the candidates of a political party, each movable part being provided with a suitable counting mechanism and mechanism for operating the counter
 10 from the movable part while maintaining positive mechanical engagement therewith, a corresponding row of irregular-balloting devices each comprising a receiver for prepared ballots and mechanism for depositing said
 15 ballots therein, interlocking devices whereby the operation of corresponding members of the regular-voting and the irregular-balloting devices at the same time is prevented, a series of movable parts in the multicandidate
 20 group, adapted to be actuated by a voter, each provided with counting mechanisms and positively-acting operating mechanisms, a corresponding row of irregular-balloting devices in the multicandidate group, movable doors
 25 protecting both the regular-voting devices and the irregular-balloting devices in the multicandidate group, interlocking mechanism arranged to permit voting for a limited number of candidates, either regular or ir-
 30 regular, or both, in the multicandidate group, and straight-ticket mechanism whereby all the regular voting devices, including those in the multicandidate group, may be operated, substantially as described.

36. The combination, in a voting-machine,
 35 of a row of movable parts adapted to be actuated by a voter and representing the candidates of a political party, each movable part being provided with a suitable counting mechanism and mechanism for operating the counter
 40 from the movable part while maintaining positive mechanical engagement therewith, a

corresponding row of irregular-balloting devices each comprising a receiver for prepared
 45 ballots therein, interlocking devices whereby the operation of corresponding members of the regular voting and the irregular balloting devices at the same time is prevented, a series
 of movable parts in the multicandidate group, 50 adapted to be actuated by a voter, each provided with counting mechanisms and positively-acting operating mechanisms, a corresponding row of irregular-balloting devices in the multicandidate group, movable doors
 55 protecting both the regular-voting devices and the irregular-balloting devices in the multicandidate group, interlocking mechanism arranged to permit voting for a limited number of candidates, either regular or ir-
 60 regular, or both, in the multicandidate group, and straight-ticket mechanism whereby all the regular-voting devices, including those on the multicandidate group, may be operated, and resetting mechanism, whereby all the
 65 regular voting and all the irregular-balloting devices in both groups, are restored to normal position, substantially as described.

37. The combination in a voting machine,
 of two or more series of movable parts in the
 70 multicandidate group, each series representing candidates of a political party, and each part being provided with a suitable protecting door, the interlocking-rods pivoted to the
 doors, and the interlocking devices supported
 75 in a suitable frame adapted to permit the actuation of two or more of the movable parts anywhere in the whole group, and the movable resetting-bar, substantially as described.

SYLVANUS E. DAVIS.

Witnesses:

GEO. WILSON,
 H. C. H. COOPER.