

M. Steiner,

Trunk.

No. 520.

Patented Dec. 20. 1837.

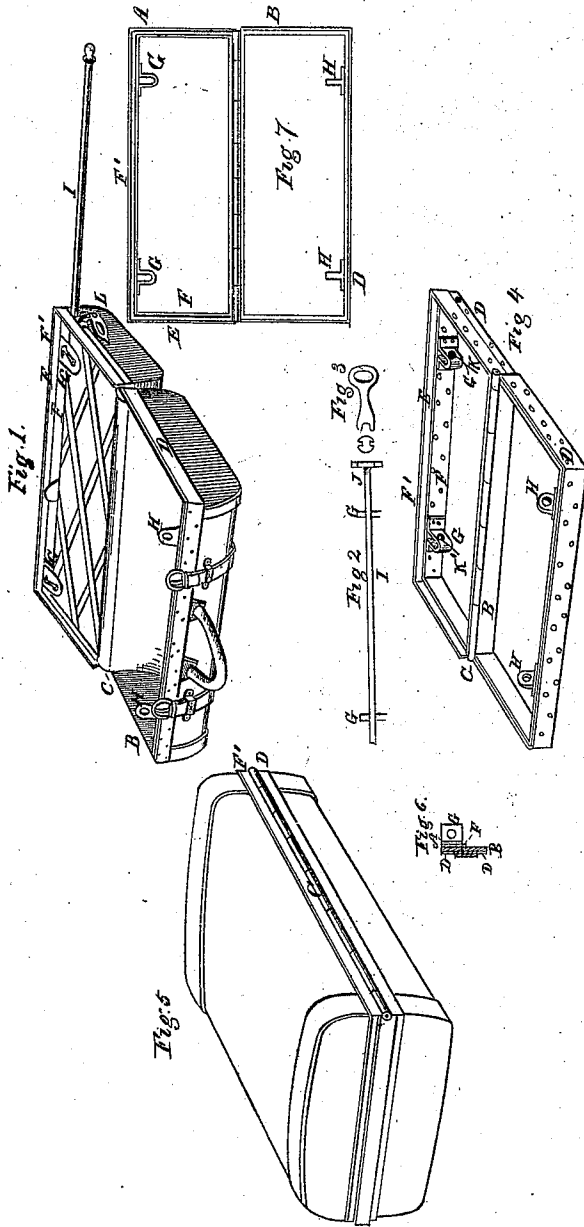

UNITED STATES PATENT OFFICE.

MATHIAS STEINER, OF NEW YORK, N. Y.

IMPROVEMENT IN THE CONSTRUCTION OF TRUNKS AND VALISES.

Specification forming part of Letters Patent No. 520, dated December 20, 1887.

To all whom it may concern:

Be it known that I, MATHIAS STEINER, of the city and county and State of New York, have invented certain new and useful Improvements in the Construction of Trunks and Valises, which are described as follows, reference being had to the annexed drawings of the same, making part of this specification.

The nature of my improvement in the construction of the trunk consists in connecting the iron frame A, Figures 1 and 4, of the top with the iron frame B of the bottom at the back by means of a metallic hinge c, extending the whole length of the trunk, riveted or otherwise fastened to said frames. The piece of metal D from which the lower part of the hinge is made extends entirely around the trunk at the place where the top and bottom come together when the trunk is closed, and their ends are lapped over each other and riveted to the frames. The piece of metal marked F' also extends entirely around the trunk, and forms not only the upper part of the hinge but also the outside finishing, as well as the outside of the channel E.

The trunk is rendered perfectly tight and proof against the entrance of water and dust by forming a channel E around the under side of the top frame by means of riveting another plate F around the inside of the frame, corresponding with that above described, forming the hinge and outside finishing which is riveted on the outside, both plates extending to any convenient distance below the lower edge of the frame to form a channel of the requisite depth. Into this channel the upper edge of the bottom frame is received when the top is shut down, which thus renders the trunk perfectly tight. The channel may be formed around the bottom frame, which will answer the same purpose. (See also Fig. 6, which represents a cross-section.) In this trunk the common lock and key are dispensed with.

The fastening is effected by means of loops, staples, and a screw-rod. The loops G are oblong, and are riveted to the upper frame, having holes K through them to receive the rods. The staples H which enter the loops are also oblong, and are riveted to the bottom frame. The aperture in each staple for the rod is made of a corresponding shape to

the rod which it is intended to receive. The rod I, Figs. 1 and 2, is made nearly the length of the trunk, and has a screw J cut on it near one end, which is screwed into a female screw in the top frame A, Fig. 1.

When the trunk is to be fastened the top is brought down upon the bottom, the loops of the top frame passing over the staples of the bottom frame. The rod is then inserted through the apertures in the frame loops and staples, the screw being screwed into the female screw in the end of the top frame, the rod being turned by means of a key made similar to a screw-driver.

For a further security the trunk may be provided with a hasp, staple, and padlock, the hasp L, Fig. 1, being riveted to the end of the top frame so that it can be brought over the end of the rod and around the corners of the trunk and then over the staple, which is riveted into the side of the frame in front and there secured by a padlock.

The valise is constructed in a similar manner. The rod, however, may be without the screw.

The invention claimed and desired to be secured by Letters Patent consists—

1. In uniting the top and bottom frames by a metallic hinge extending the whole length of the trunk on the back, riveted to the top and bottom frames (instead of using the leather covering as the hinge,) said hinge being formed of the pieces of metal which extend entirely around the trunk forming the outside covering or finishing D and F, as before described.

2. In forming a channel around the under side of the top frame into which is received the upper edge of the bottom frame, by which the trunk is rendered perfectly secure against the entrance of dust or water, or in forming the channel around the bottom frame, into which the top frame is received for a similar purpose.

3. In the mode of securing the trunk or valise by means of the loops, staples, and screw-rod, as before described, instead of the common lock and key.

MATHIAS STEINER.

Witnesses:

WM. P. ELLIOT,
WM. BISHOP.