

C. DUPUIS.
BEVERAGE DISPENSING APPARATUS.

APPLICATION FILED FEB. 9, 1904.

3 SHEETS—SHEET 1.

Fig. 8

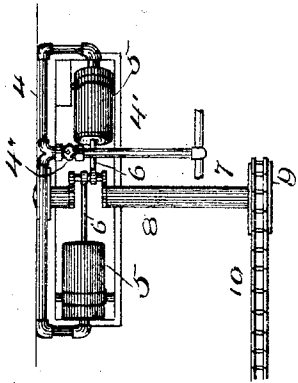

Fig. 6.

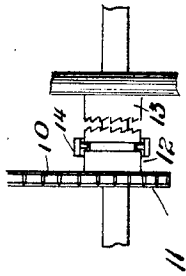
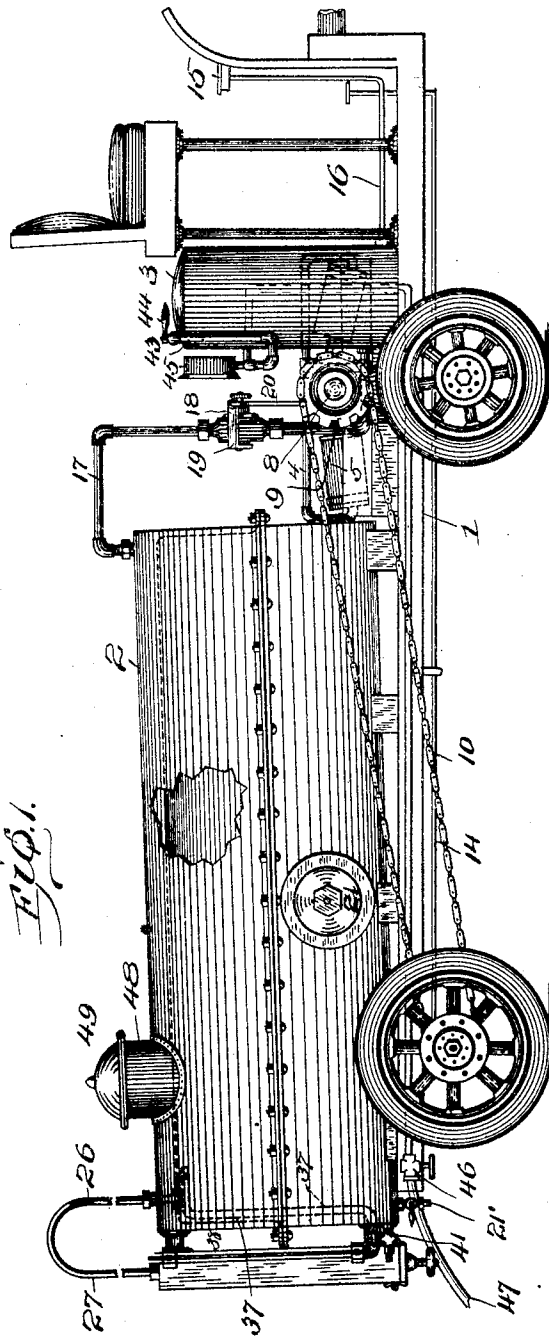

Fig. 1.



WITNESSES:

Russell Severance
Edgar M. Kitchin

INVENTOR

Cyrille Dupuis
BY
Mason, Fenwick & Lawrence
ATTORNEYS.

C. DUPUIS.
BEVERAGE DISPENSING APPARATUS.
APPLICATION FILED FEB. 9, 1904.

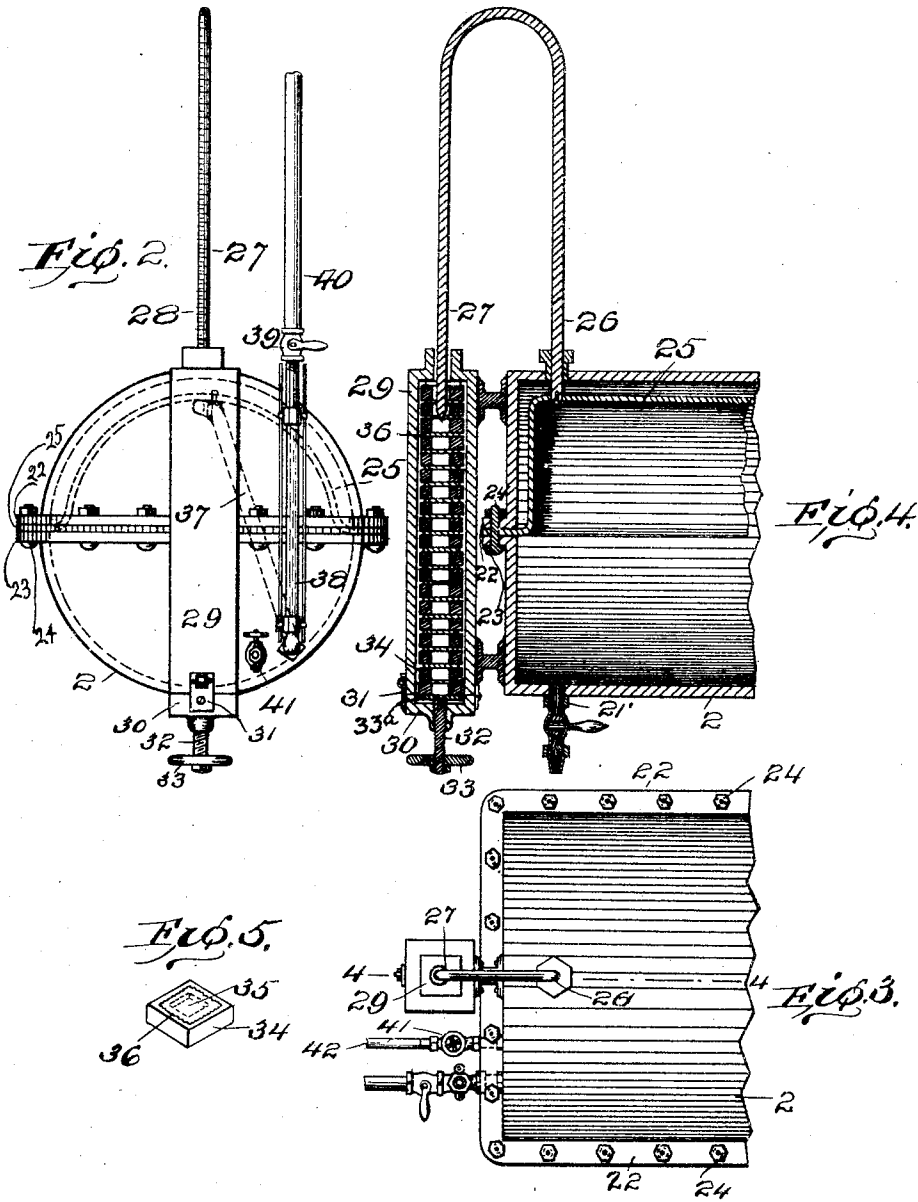

WITNESSES:
Russell Severance
Edgar M. Kitchin

INVENTOR
Cyelle Dupuis
 BY
Marion Lawrence
 ATTORNEYS

C. DUPUIS.
BEVERAGE DISPENSING APPARATUS.
APPLICATION FILED FEB. 9, 1904.

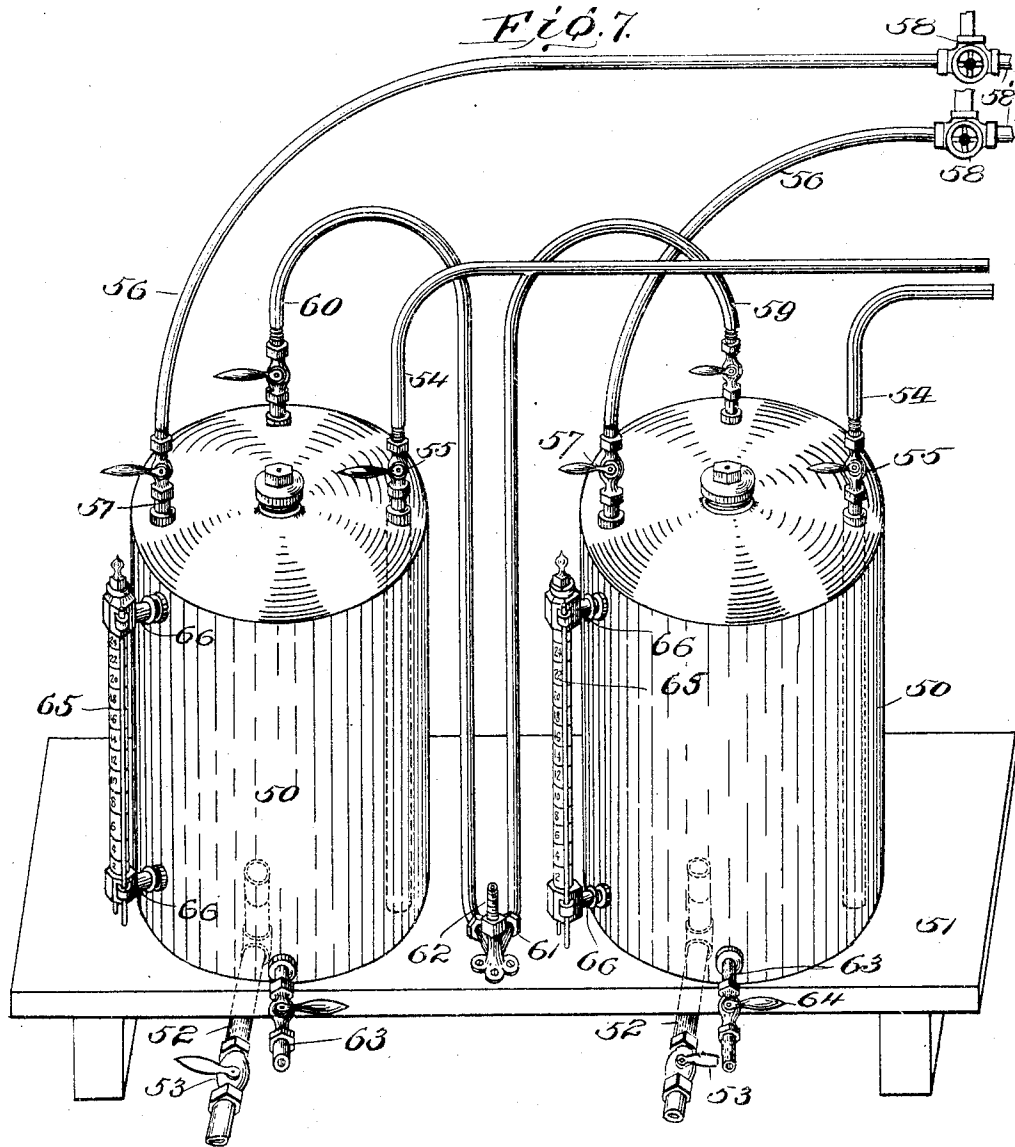

WITNESSES: *Carroll Severance* *Cyrille Dupuis* INVENTOR
Edgar M. Kitchin *Mason Fenwick Lawrence* BY
 ATTORNEYS.

UNITED STATES PATENT OFFICE.

CYRILLE DUPUIS, OF FALL RIVER, MASSACHUSETTS, ASSIGNOR OF ONE-HALF TO ELZEAR FOURNIER, OF FALL RIVER, MASSACHUSETTS.

BEVERAGE-DISPENSING APPARATUS.

SPECIFICATION forming part of Letters Patent No. 788,893, dated May 2, 1905.

Application filed February 9, 1904. Serial No. 192,825.

To all whom it may concern:

Be it known that I, CYRILLE DUPUIS, a citizen of the United States, residing at Fall River, in the county of Bristol and State of Massachusetts, have invented certain new and useful Improvements in Beverage - Dispensing Apparatus; and I do hereby declare the following to be a full, clear, and exact description of the invention, such as will enable others skilled in the art to which it appertains to make and use the same.

This invention relates to improvements in the art of delivering and dispensing liquids, and has particular reference to devices designed especially for use in connection with the delivering of beverages.

The object in view is the provision of means for indicating the quantity of liquid delivered and means for canceling revenue-stamps relative to such quantity.

With this and further objects in view the invention comprises the combination, with a receptacle, of a diaphragm therein and stamp-canceling means actuated by said diaphragm.

It further comprises the combination, with a receptacle designed to contain a liquid, of a diaphragm within said receptacle designed to be supported upon the contained liquid, means for supplying pressure between the diaphragm and the walls of said receptacle, and a gage actuated by said diaphragm.

It also comprises certain other novel constructions, combinations, and arrangements of parts, as will be hereinafter fully described and claimed.

In the accompanying drawings, Figure 1 represents a view in side elevation of delivering mechanism embodying the features of the present invention. Fig. 2 represents a rear elevation of the same on an enlarged scale, the carriage being omitted. Fig. 3 represents a fragmentary top plan view of the same. Fig. 4 represents a longitudinal vertical central section taken on the plane of line 4 4 of Fig. 3. Fig. 5 represents an enlarged detail perspective view of one of the stamp-carrying blocks. Fig. 6 represents a detail view of the pump-driving-chain clutch and surrounding parts. Fig. 7 represents a

perspective view of the beverage-receiving tanks. Fig. 8 represents a detail top plan view of the pumping mechanism.

In the present art it is found desirable to employ a reservoir or tank mounted upon a suitable carriage and designed to contain a supply of beverage for delivery to fixed receptacles at the point or points where the beverage is to be dispensed, the manufacturer of the beverage by the employment of such delivering tank or receptacle saving the expense of the use of barrels, and by the employment of the particular containing-receptacles disclosed in Fig. 7 of the accompanying drawings the quantity of the beverage delivered at the dispensing-point may be definitely determined and in practice the retail dealer may thus be definitely informed as to the quantity of beverage delivered and the quantity of beverage on hand at all times. Hence my present improvement is of utility both to the manufacturer and to the retailer, and said improvement will be understood by reference to the accompanying drawings, in which—

1 indicates a suitable carriage of any ordinary type, upon which is mounted a suitable tank or receptacle 2 for containing the beverage to be dispensed.

Mounted upon the carriage 1 is a suitable pressure-tank 3, designed to be supplied with atmospheric pressure through suitable pipes 4, receiving the supply of compressed air from suitable oscillating cylinder-pumps 5 5, said pumps being provided with pistons 6 6, engaging a crank 7 of crank-shaft 8, journaled in suitable bearings upon the carriage 1. A sprocket-wheel 9 is carried by the free end of the shaft 8 and is designed to be actuated by a chain 10, which is passed about said sprocket 9 and about a sprocket 11, carried by a clutch member 12, designed to engage a similar clutch member 13, carried by one of the supporting-wheels of the carriage 1. A shifting-lever 14 engages the clutch member 12 and extends forwardly to a point in position to be operated by the driver or other person at the front end of the carriage 1 for facilitating throwing of the clutch member 12 into and out of operative relation with the clutch mem-

ber 13, whereby the desired pressure may be maintained in the tank 3, a pressure-gage 15 being arranged in position for being observed by the driver or operator and being in communication with the tank 3 through a suitable pipe 16.

The branches of pipe 4 unite centrally into a main pipe 4', provided with a check-valve 4'', preventing back pressure. The end of the pipe 4' is provided with a T connection having one branch communicating with the tank 3 and the other branch connected with a pipe 17. The pipe 17 communicates with the upper portion of tank 2, and the pressure within the pipe 17 is controlled by a suitable automatic valve 18, whose stem is preferably engaged by a yoke 19, in turn engaged by an operating-rod 20. When desired, the rod 20 may be manually operated for adjusting the position of valve 18, whereby the desired amount of pressure may be admitted through pipe 17 into tank 2.

I have illustrated a cleaning-out head 21 removably positioned within the side of the tank 2; but of course said head may be positioned at any desired point on said tank. A drain-pipe 21' communicates with the lower end of the tank 2 and is controlled by a suitable plug-valve for permitting the discharge of the wash-waters after the tank has been cleaned through the cleaning-out opening closed by head 21.

The tank 2 is preferably divided horizontally centrally, and the upper half is provided with a horizontal flange 22, adapted to rest upon and be secured to a similar flange 23, extending from the lower half of the tank, said flanges being preferably secured together by a number of suitable bolts 24. A diaphragm 25 divides the tank 2 into two compartments, and said diaphragm extends beyond the walls of the tank and is secured on all sides between the flanges 22 and 23, whereby liquid introduced into the lower compartment of the tank will be prevented from entering the upper compartment of the tank except by lifting said diaphragm. The diaphragm 25 is preferably made of a rubber blanket designed to be expanded upwardly by the pressure of contained liquid or expanded downwardly when the greater amount of the liquid has been discharged, said downward expansion being effected by means of the pressure admitted through pipe 17. Of course the diaphragm 25 need not necessarily be made of expansible rubber, but may be made of a flexible blanket of sufficient area to permit the filling of the tank 2 with liquid from beneath or filling of the said tank with air-pressure from above. The bolt 24 retains the sections of the tanks 2 in position and also retains the diaphragm 25 in position, said diaphragm being thus removably retained in place, whereby the same may be readily renewed when worn.

A vertically-reciprocating standard 26 extends through the upper wall of the tank 2 and has its lower end engaging the diaphragm 25, whereby said standard 26 is adapted to be moved longitudinally relative to the vertical expansion or retraction of the said diaphragm. The standard 26 is curved at its upper end and extends downwardly in the form of a vertical gage-standard 27. The gage-standard 27 may be provided with suitable marks of graduation, as seen at 28. The lower end of the standard 27 is inclosed within a vertical housing 29, the position of the graduations 28 being gaged by their relation to the upper end of said housing 29. The housing 29 is formed at its lower end with a hinged cap 30, provided with a suitable latch mechanism 31, designed to removably retain said cap in a closed condition. A vertical shaft 32 is threaded through the cap 30 and is provided with a hand-operated wheel 33, adapted to be rotated for threading said shaft 32 either forwardly or downwardly in the cap. The inner upper end of the shaft 32 carries a plate 33', upon which may rest a plurality of blocks 34, the housing 29 being adapted to contain a column of such blocks. One of the blocks 34 is seen in detail in Fig. 5, and said block is provided with a central aperture 35, designed to permit the passage of the lower end of the standard 27, said lower end being preferably formed with a penetrating-point. A revenue-stamp 36 of any desired denomination is adapted to be carried by each of the blocks 34. In practice for the purpose of illustration we will assume that the smallest denomination of revenue-stamp which can be employed receives eight gallons of the beverage to be dispensed, in which case the dispensing of eight gallons of such beverage from the tank 2 will permit the diaphragm 25 to move to a sufficient extent for throwing the standard 28 downwardly far enough for causing the standard 27 to descend a distance equal to the thickness of one of the blocks 34 and to penetrate one of the stamps 36. The column of blocks 34 within the housing 29 is equal in height to the vertical diameter of the tank 2, whereby when the said tank is empty the penetrating-point of the gage-standard 27 will have passed through the stamp carried by the lowermost block 34. The shaft 32 may be adjusted vertically for positioning the column of blocks 34 accurately for permitting the penetration of the stamps carried by said blocks in timed relation to the descent of the diaphragm 25 within the tank 2.

A flexible tube 37 is connected to the under side of the diaphragm 25 and extends to a point near the bottom of the tank 2, at which point it extends through the rear wall of said tank. Connected with the lower end of the pipe 37 is a glass or other transparent tubular gage 38, arranged in a vertical position and preferably provided at its upper end with a

suitable faucet 39, adapted to receive the end of a suitable hose 40. The hose 40 is designed to be used only during the operation of filling the tank 2 and leads to the supply-vat for purposes hereinafter mentioned. An intake and discharge faucet 41 connects with the end of the tank 2 just to one side of the lower end of the tube 38. The faucet 41 is adapted to receive a hose 42 for purposes hereinafter specified.

A pipe 43 communicates with the tank 3 and is provided with a controlling cut-off 44. The pipe 43 extends downwardly and communicates with a pressure-gage 45 for indicating the pressure within said tank, the pipe 44 being further extended along the carriage 1 and provided at its rear end with a faucet 46, adapted to receive the end of a hose 47 for purposes hereinafter specified.

A casing or housing 48 is preferably mounted on top of the tank 2 and provided with a suitable hinged cap 49 for closing the upper end thereof. The housing 48 is designed to receive the hose 47 when the same is not in use.

In connection with the above-described delivering-tank I employ suitable receiving-tanks, as indicated at 50 50, which are designed to be positioned, say, for instance, in the cellar of the retail dealer, the tanks 50 being provided with elements coacting with and depending upon the elements of the structure heretofore described for their operation, the elements heretofore described being also dependent upon the coöperation of the parts connected to the tanks 50 for their effective operation. The tanks 50 are mounted upon a suitable support 51, and a drain-pipe 52 extends through the support 51 and into each of the tanks 50, a suitable faucet 53 being interposed in the length of each pipe 52 for controlling the discharge therefrom. An intake or supply pipe 54 extends into each of the tanks 50 and projects downwardly therein to a point near the bottom thereof, as indicated in dotted lines in Fig. 7, and each of the pipes 54 is provided with a valve 55 for controlling the passage of pressure therethrough. The free end of each pipe 54 is adapted to receive the free end of the hose 42 during the filling of the respective tank 50. Connected with the upper end of each of the tanks 50 is a pressure-controlling pipe 56, a cut-off 57 being interposed in the length of each pipe 56 and each pipe 56 being provided at its free end with a three-way valve 58 and a hose-receiving extension 58', each of the said extensions 58' being adapted to receive the hose 47 when the respective tank 50 is being filled. The pipe 59 rises from one of the tanks 50, and a similar pipe 60 rises from the other of said tanks, and said pipes 59 and 60 are curved downwardly and extend to and converge in a suitable tubular bracket 61, fixed to the base 51 and provided with a threaded nipple 62, designed to receive a tube of any suitable type extend-

ing to a pressure-tank arranged above, (not illustrated,) the pressure of the said tank being adapted to be controlled by the given retail dealer. A pipe 63 leads from the lower end of each of the tanks 50, and each pipe 63 is provided with a controlling-valve 64, the pipes 63 extending to the desired point for delivery of the beverage from within the respective tank 50.

In operation the hose 40 is attached to the faucet 39 and the hose 42 is attached to faucet 41, and a beverage is supplied under pressure through the hose 42, the supply being continued until the diaphragm 25 has assumed the position indicated in Figs. 1, 2, and 4, whereupon the liquid will begin to flow out through the pipe 40 back to the vat. The liquid supplied may cause the diaphragm 25 to lift to the position indicated before the tank is entirely full of clear liquid, due to effervescence, and in this instance the operator watches the gage 38 until all the foam has been discharged therethrough and the clear liquid begins to flow through said gage. As soon as this occurs the supply is cut off and a hose 42 removed and placed within the housing 48. The cap 30 of housing 29 is next opened, and a column of blocks 34 is introduced into said housing and secured therein by the closing of the cap 30. Each of the blocks introduced is of course provided with the necessary revenue-stamp. While the vehicle 1 is moving from place to place the driver throws the clutch member 12 into operative relation with the clutch member 13, whereby the pumps 5 will be caused to operate. As the pumps 5 continue to operate the pressure within the tank 3 rises to the desired extent, as indicated by the gage 15, whereupon the lever 10 is shifted for throwing the clutch member 12 out of operation. When the vehicle 1 has arrived at the place of the retail dealer, the hose 47 is applied to the faucet 46 and the opposite end of said hose is applied to the hose extension 58' of one of the pipes 56, the valve 57 being opened and the valve 58 being positioned for establishing communication between said hose and the pipe 56. The cut-off 44 is next opened for permitting pressure to enter the respective tank 50 through the hose 47, and the operator at the rear of the tank 2 observes the pressure within the respective tank 50 by the position of the pointer of pressure-gage 45. When the pressure in said tank 50 has raised to the desired extent, the hose 42 is applied to the faucet 41 and connected to the pipe 54 of the respective tank 50 to which the pressure has been applied, and the controlling-valve 55 is opened for admitting the liquid from the pipe 2. The pressure within the tank 2, supplied through pipe 17, will be approximately equal to or slightly greater than the pressure in the respective tank 50, so that the liquid will flow readily under the action of gravity from the tank 2

into the tank 50, while the pressure within the given tank 50 will be sufficient for preventing effervescence or too rapid discharge of liquids into said tank, the pressure within the tank 50 being permitted to discharge into the atmosphere through the three-way valve 58, the escape of pressure being sufficiently slow for permitting the filling of the given tank without producing foam on the surface of the incoming liquid. Each of the tanks 50 is provided with a transparent tubular gage 65, arranged parallel to its vertical wall, and communicates with its respective tank by upper and lower tubes 66 66, the gage 65 being marked off with suitable lines of graduation. Said gage 65 readily facilitates the ascertaining of the exact amount of liquid within the receptacle 50 and also facilitates the determining of the amount of liquid supplied to said tank at any given time. As soon as one of the tanks 50 is filled the hose 47 is applied to the other of the pipes 56, and pressure is thereby supplied to the other tank 50, and said tank is filled by the application of the hose 42 to the other of the pipes 54, the pressure being permitted to escape into the atmosphere gradually from the last-mentioned tank 50 through the respective three-way valve 58.

Having thus fully described my invention, what I claim as new, and desire to secure by Letters Patent, is—

1. In a beverage-dispensing apparatus, the combination with a receptacle, of stamp-canceling means carried thereby, and means within the receptacle for actuating said stamp-canceling means.

2. In a beverage-dispensing apparatus, the combination with a receptacle, of stamp-carrying means, a pointer designed to penetrate the stamps carried by said carrying means, and means within said receptacle engaging said pointer for actuating the same to a degree relative to the quantity of beverage dispensed.

3. In beverage-dispensing apparatus, the combination with a receptacle, of a diaphragm therein, and stamp-canceling means actuated by said diaphragm.

4. In beverage-dispensing apparatus, the combination with a receptacle, of a flexible diaphragm disposed therein of sufficient size for adapting the same to conform to the contour of the walls of said receptacle, and a

flexible tube connected with said diaphragm and discharging outside the receptacle.

5. In beverage-dispensing apparatus, the combination with a receptacle, of a diaphragm therein, and a stamp-canceling standard actuated by said diaphragm.

6. In beverage-dispensing apparatus, the combination with a receptacle, of stamp-carrying means, means for canceling the stamps carried thereby, and means within said receptacle for actuating said stamp-canceling means.

7. In beverage-dispensing apparatus, the combination with a receptacle, of a housing at one side thereof, stamp-carrying blocks arranged within said housing, a reciprocating standard designed to penetrate the stamps carried within said housing, and means within said receptacle for reciprocating said standard.

8. In beverage-dispensing apparatus, the combination with a receptacle, of a housing at one side thereof, a hinged cap normally closing said housing, stamp-carrying means within said housing, means carried by said cap for adjusting said stamp-carrying means within the housing, stamp-canceling means, and means within said receptacle for actuating said stamp-canceling means.

9. In beverage-dispensing apparatus, the combination with a receptacle, of a diaphragm therein, a tube connected with said diaphragm, and a gage connected with said tube.

10. In beverage-dispensing apparatus, the combination with a receptacle, of a diaphragm therein, a flexible tube connected with said diaphragm, a gage connected with said tube, and a hose connected with said gage.

11. In beverage-dispensing apparatus, the combination with a receptacle, of a diaphragm dividing the same into compartments, one of said compartments being designed to contain liquid, a tube within said liquid-receptacle engaging said diaphragm, and a transparent tube connected with the said tube.

In testimony whereof I hereunto affix my signature in presence of two witnesses.

CYRILLE DUPUIS.

Witnesses:

MARY S. HANDY,
EDGAR M. KITCHIN.