

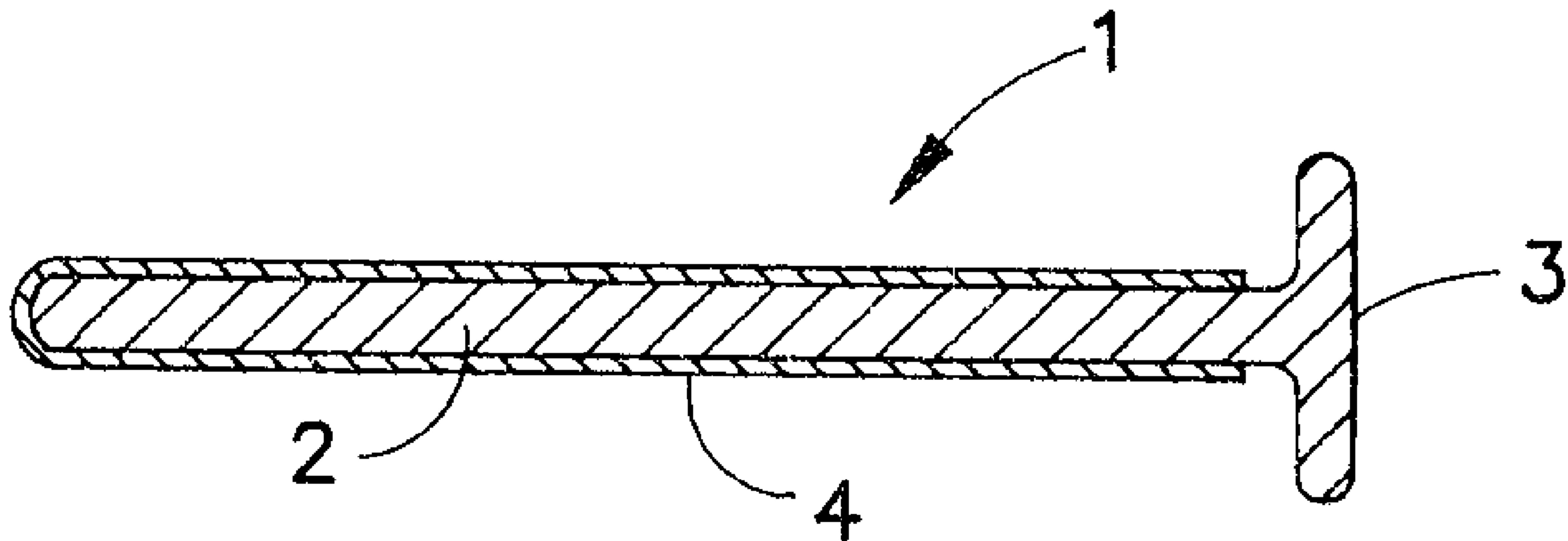

(22) Date de dépôt/Filing Date: 1991/04/22  
 (41) Mise à la disp. pub./Open to Public Insp.: 1991/10/26  
 (45) Date de délivrance/Issue Date: 2001/12/04  
 (30) Priorité/Priority: 1990/04/25 (07/514,397) US

(51) Cl.Int.<sup>5</sup>/Int.Cl.<sup>5</sup> A61M 37/00, A61K 31/00  
 (72) Inventeurs/Inventors:  
 Berggren, Randall G., US;  
 Gale, Robert M., US;  
 Place, Virgil A., US  
 (73) Propriétaire/Owner:  
 Vivus, Inc., US  
 (74) Agent: SMART & BIGGAR

(54) Titre : TRAITEMENT DES TROUBLES DE L'ERECTION  
 (54) Title: TREATMENT OF ERECTILE DYSFUNCTION



(57) Abrégé/Abstract:

Erectile dysfunction, particularly impotence, priapism and Peyronie's disease is treated by the transurethral administration of a therapeutically effective agent. The agents are administered to the urethra by means of a penile insert (1) having a rapidly releasing coating (4) containing the agent on its exterior surface or by means of an inserter (27) carrying an agent containing dose of agent (31) which can be displaced into the urethra.

ARC 1747 CIP1

67696-177

ABSTRACT

Erectile dysfunction, particularly impotence, priapism and Peyronie's disease is treated by the transurethral administration of a therapeutically effective agent. The agents are administered to the urethra by means of a penile insert (1) having a rapidly releasing coating (4) containing the agent on its exterior surface or by means of an inserter (27) carrying an agent containing dose of agent (31) which can be displaced into the urethra.

G:\1747\AMD-CLMS.PCT\DGJ

A

TREATMENT OF ERECTILE DYSFUNCTIONTechnical Field

This invention relates to the treatment of erectile disfunction  
5 and more particularly to the treatment of impotence, priapism and  
Peyronie's syndrome.

Background of the Invention

As used herein, the term "erectile dysfunction" refers to  
certain disorders of the cavernous tissue of the penis and the  
10 associated fascia which produce impotence, the inability to attain a  
sexually functional erection; priapism, the persistent and often  
painful erection of the penis; and Peyronie's syndrome, a condition  
characterized by fibrosis of the cavernous tissue and associated  
painful and distorted erection of the penis. Erectile dysfunctions,  
15 particularly impotence, affect a substantial number of patients. For  
example, impotence is estimated to affect approximately 10 million  
American men and can result from any of numerous physiological or  
psychological factors which cause the blood flow to and from the  
penis to remain in balance thereby preventing retention of sufficient  
20 blood to cause rigid dilation of the corpus cavernosa and spongiosa.  
As used herein, the term "impotence" is used in its broadest sense as  
the inability to attain a sexually functional erection when desired.  
Treatments for impotence include psychosexual therapy, hormonal  
therapy, administration of vasodilators such as nitroglycerin and  
25  $\alpha$ -adrenergic blocking agents (hereafter " $\alpha$ -blockers"), vascular  
surgery, implanted penile prostheses, vacuum devices and external  
aids such as penile splints to support the penis or penile  
constricting rings to alter the flow of blood through the penis. See  
Robert J. Krause, et al., Impotence, N. Eng. J. Med. Vol. 321, No.  
30 24, December 14, 1989 for a general discussion of the current state  
of the art.

In 1980, Dr. R. Verig of Paris first demonstrated that  
impotence could be physiologically treated by the direct injection of  
a vasoactive drug into a patient's epigastric artery and thereafter  
35 thousands of patients have treated their impotence by self injection

2040914<sup>91</sup>

ARC 1747 CIP1

67696-177

1-a

of such drugs directly into the corpora cavernosa. Forward, 1<sup>er</sup>  
Symposium International Sur L'Erection Pharmacologique, 17-19  
November 1989, Paris, p. 2; R. Virag, et al, Intracavernous Injection

of Papaverine as a Diagnostic and Therapeutic Method in Erectile Failure, Angiology, 35, pp. 79-87, 1984; (See also, U.S. Patents 4,127,118, 4,766,889 and 4,857,059).

5 The drugs most commonly used include  $\alpha$ -blockers, such as the long acting phenoxybenzamine and the short acting phentolamine, smooth muscle relaxants such as papaverine, prostaglandins having a vasoactive function such as prostaglandin-E<sub>1</sub> (PGE<sub>1</sub>) and combinations of such drugs having different receptor effects to enhance therapy.

10 Erection producing intracavernous injection doses of papaverine are typically in the range of about 7.5 to 160 mg, of phentolamine are in the range of about 0.1 to 10 mg of and of PGE<sub>1</sub> are in the range of about 2.5 to 50 micrograms. See for example, Kurkle, et al, Injection Therapy for Impotence Urol. Clin. of America, Vol. 15, No. 4, Nov. 88, pp. 625-629 and N. Ishii, et al, Intra Cavernous Injection of Prostaglandin E for the Treatment of Erectile Impotence, J. of Urol., Vol. 141, Feb. 1989, pp. 323-325. Vasoactive intestinal peptides at doses of 10-100  $\mu$ g have also been reported as producing erection on intracavernous injection. See also, H. Handelsman,

20 Diagnosis and Treatment of Impotence, U.S. Dept. of Health Services, Agency for Health Care Policy and Research, April 1990, for a summary of intracavernous injection and other treatment of impotence.

Although intracavernous injection of vasoactive drugs can produce a relatively rapid onset of erection in patients suffering

25 from impotence attributable to venous leakage or arterial insufficiency; patients often find the injections psychologically disturbing, painful, traumatic or inconvenient as evidenced by a high discontinuance rate. See S. Althouf, et al, Why Do So Many People Drop Out From Auto-Injection Therapy for Impotence?, Journal of Sex & Marital Therapy, Vol. 15, No. 2, 1989, pp. 121-129. Adverse side effects including priapism, corporeal nodules and diffuse fibrosis, drug tolerance, bruising and hematomas. Swelling and ulceration of penile skin at the injection site have also been reported.

Nevertheless, because of the relatively innocuous intervention

35 involved and the high failure rate of penile prostheses, the pharmacological approach to the treatment of impotence is still quite

2-a

advantageous to a large number of patients and could be even more so if the side effects could be avoided. The administration of vasodilators via the male urethra has been disclosed in Kock, EPA  
5 0357581 to produce erections as has the transurethral administration of testosterone, S. M. Milco, Bulletins et Memoirs de la Societa Roumaine D'Endocrinologie, Vol. 5, pp. 434-437 (Dec. 1939). It has also been suggested that cocaine administered transurethrally could contribute to an erection although the reported side effects were  
10 catastrophic, JAMA, Vol. 259, NO. 21, page 3176 (1988).

Priapism is less common than impotence and can be attributed to various causes. It has been associated with diseases producing intravascular agglutination or sludging, such as leukemia, and pharmacological priapism has been reported in a small percentage of patients who are treated for impotence by intracavernous injection. Priapism has been treated by intracavernous injection of vasoconstrictors such as  $\alpha$ -adrenergic receptor agonists (hereafter " $\alpha$ -agonist"). The reported effective doses of the  $\alpha$ -agonist, phenylephrine, are in the range of about 0.1 to 2 mg.

Peyronie's syndrome is a condition of unknown etiology characterized by fibrosis of the cavernous tissues and painful and distorted erections. The current treatment consists of injection of steroids and other anti-inflammatory agents into the site of the fibrosis.

With respect to administration of drugs directly to the penis, medicated catheters such as described in U.S. Patent 4,640,912 have been used to prevent or treat localized infections and irritation of the urethra and bladder; a nitroglycerin coated, erection inducing condom is disclosed in U.S. Patent 4,829,991; the transurethral administration of certain drugs is suggested in U.S. Patents 4,478,822, 4,610,868, 4,640,912 and 4,746,508; and medicated urethral suppositories, inserts or plugs, typically containing anti-infective agents or spermicides are disclosed in U.S. Patents 1,897,423, 2,584,166, 2,696,209 and 3,373,746, for example. As noted above, Kock and Milco disclose introducing agents into the urethra to induce erections.

According to our invention, we have provided methods and dosage forms for the treatment of erectile dysfunction which are painless, capable of rapidly, safely and effectively producing erection of the penis in the case of impotence, detumescence of the penis in the case of priapism and administration of anti-inflammatory drugs to fibrotic sites in the case of Peyronie's syndrome without the above described adverse side effects and with a high degree of patient acceptability.

3a

The invention provides an apparatus for use in treating erectile dysfunction comprising:

a) a shaft which can be inserted into the urethra of a male patient, and

b) a composition including a therapeutic amount of a therapeutic agent which is retained on or in said shaft prior to insertion in the urethra wherein the total amount of said composition does not exceed 100 mg;

said shaft and said composition being arranged such that, on insertion of the shaft into the urethra, the composition is delivered at a depth of at least 1 cm into the urethra.

The invention further provides use of a therapeutic agent for erectile dysfunction dispersed in a dispersant selected from the group consisting of pharmaceutically acceptable materials which are solid at refrigerator or ambient temperatures and which dissolve, melt or bioerode within a patient's urethra to release the agent to treat erectile dysfunction in a patient.

The invention further provides a commercial package comprising an apparatus of the invention together with instructions for use thereof to treat erectile dysfunction.

77971-1

Brief Description of the Invention

We have found that the above-described erectile dysfunctions can be safely and effectively treated by the transurethral administration of the appropriate therapeutic drug or combination of therapeutic drugs (as used herein the term "agent" refers to a drug or a combination of drugs capable of producing the desired therapeutic effect) and have provided compositions and penile inserts adapted to be easily and painlessly inserted into the urethra, which compositions or inserts carry the appropriate therapeutic agent in an amount sufficient to produce the desired result.

In one preferred embodiment of this invention the therapeutic agent is applied as a coating on a penile insert configured to prevent complete insertion and to facilitate removal.

In another preferred embodiment of this invention, the agent is contained in a gel, cream, ointment or suppository for example which may be deposited in the urethra from a specially designed inserter.

Brief Description of the Drawings

This invention and the advantages thereof will be readily apparent from the following description of the invention with reference to the accompanying drawings wherein:

Figure 1 is a cross sectional view of one embodiment of this invention;

Figure 2 is a cross sectional view of another embodiment of this invention;

Figure 3 is an exploded view of a penile insert according to the invention and its container;

Figure 4 is a side view, partly in section, of an inserter/container assembly for introducing a composition containing a dose of agent into the urethra; and

Figure 5 is a top view of the inserter/container of Figure 4.

Description of the Invention Including the Best Mode

In its broadest aspect, this invention contemplates the treatment of erectile dysfunction by the transurethral administration of an agent, therapeutically effective with respect to the dysfunction, directly into the blood supplying the corpus cavernosum via the cross circulation with the spongiosa surrounding the urethra.

The erectile dysfunctions which may be so treated include impotence, for which the therapeutic agent is one or more drugs capable of producing a vaso-dilatory or other erection inducing effect.

5 Suitable vaso-dilatory agents include nitrates such as nitroglycerin and isosorbide dinitrate, long and short acting  $\alpha$ -blockers such as phenoxybenzamine, dibenamine, doxazosin, terazosin, phentolamine, tolazoline, prazosin and trimazosin; adenosine, ergot alkaloids, chlorpromazine, haloperidol, yohimbine, verapamil and other calcium  
10 blockers, natural and synthetic vasoactive prostaglandins and analogs thereof such as PGE<sub>1</sub>, alprostadiol and misoprostol, for example, vasoactive intestinal peptides or any other agent which is capable of producing an erection when administered transurethally. For example, dopamine agonists such as apomorphine and bromocriptine and  
15 opioid antagonists such as naltrexone have been reported to induce erection and they may also be useful according to this invention. See S. Lal et al, Apomorphine: Clinical Studies on Erectile Impotence and Yawning, Prog. Neuro-Psychopharmacology, Vol. 13, 1989, pp. 329-339 and A. Fabbri et al, Endorphines in Male Impotence, Evidence for Naltrexone Stimulation of Erectile Activity in Patient  
20 Therapy, Psychoneuroendocrinology, Vol. 14, No. 1 & 2, pp. 89, 103-111.

With respect to priapism, the therapeutic agent may be one or more vasoconstrictor drugs. Suitable vasoconstrictors include  $\alpha$ -  
25 receptor agonists such as epinephrin, phenylethylamine, norepinephrine, dopamine, metaraminol, phenylephrine, methoxamine, ephedrine, phenylpropanolamine, mephentermine and propylhexedrine, for example,  $\beta$ -blockers such as butoxamine, dichloroisoproterenol, propranolol, alprenolol, bunolol, nadolol, oxprenolol, penbutolol,  
30 pindolol, sotalol, timolol, metoprolol, atenolol, acebutolol, bevantolol, pafenolol, and tolamolol, for example, and any other agent which is capable of producing a detumescent effect when applied transurethally.

With respect to Peyronie's syndrome, the therapeutic agent may  
35 be one or more anti-inflammatory drugs such as corticosteroids including cortisone, hydrocortisone, tetrahydrocortisone, prednisone, prednisolone, methylprednisolone, fludrocortisone, desoxycortisol,

77971-1

6

corticosterone, triamcinolone, paramethasone, betamethasone, dexamethasone and beclomethasone, for example, non-steroidal anti-inflammatories such as salicylic acid, aspirin, diflunisal, methyl salicylate, phenylbutazone, oxyphenbutazone, 5 apazone, phenacetin, acetaminophen, indomethacin, sulindac, mefenamic acid, meclofenamate sodium, tolemetin, ibuprofen, naproxen and fenoprofen, for example, and other drugs such as testosterone which may be capable of producing an anti-inflammatory effect on fibrous tissue within the corpus 10 cavernosum when administered transurethrally.

It is preferred that the agent be rapidly delivered through the urethra in order to bring about a rapid onset of the desired effect. To that end the agent containing material is caused to contact the urethra along a sizable portion, about 15 2-3 cm, of its length rather than localizing it at one site along the urethra. Also, the agent should be applied at least 1 cm into the penis and past the point where the transition from the epidermal character of the glans has been completed.

In all of the dosage forms contemplated herein, it is 20 desirable that the volume of agent-containing material that is deposited in the urethra remain therein until complete absorption of the agent has occurred and that the material be deposited in a manner that permits relatively rapid absorption of the agent. Volumes in the range of 50-100 mg (approximately 25 50-100  $\mu$ l) tended to exhibit observable spillage prior to complete absorption. Accordingly, the amount of drug-containing material retained in the urethra is preferred to be below about 50  $\mu$ l. Adequate lubrication has been obtained with as little as 5-10  $\mu$ l of lubricating carriers such as 30 polyethylene glycol (PEG) 1000 and 1450.

77971-1 ,

6a

The dose of agent can be contained in the form of fluid or semi-fluid solutions, suspensions, dispersions, ointments, pastes or gels selected from the numerous formulations of such types known to the art but preferably  
5 comprises a formulation in which the agent is dispersed in a pharmaceutically acceptable carrier which rapidly releases the agent within the urethra which can be easily introduced into the urethra from a flexible tube, squeeze bottle, pump or aerosol spray single or multiple dose administrator, for  
10 example. The agent may also be contained in rapidly releasing coatings or suppositories which are rapidly dissolved absorbed, melted or bioeroded in the urethra. Urethral permeation enhancers for the agent may also be included in the agent containing composition. In certain embodiments which are  
15 illustrated in Figures 1 and

ARC 1747 CIP1

7

3, the agent is included in a coating on the exterior surface of a penile insert.

5 In another embodiment illustrated in Figures 4 and 5 the agent is contained in a dose of predetermined volume which is deposited as a suppository into the urethra at the desired location.

10 Referring now to Figure 1, a penile insert 1 comprises a shaft portion 2 which is sized to be easily and comfortably inserted into the male urethra. Means are also provided to prevent complete insertion of the inserter into the urethra in a manner that would make removal difficult. The means may simply be a portion of the shaft of adequate length to be gripped and not released during use. It is preferable however that the end of shaft 2 is provided with an enlarged terminal portion 3 configured to prevent complete insertion into the urethra and to facilitate removal of the device after the agent has been delivered. The internal end of shaft portion 2 is preferably provided with a rounded, blunted end to prevent discomfort on insertion and is typically from about 3 to 5 millimeters in diameter and from about 2 to 12 centimeters in length.

20 The insert itself may be made from any pharmacologically acceptable material and although it may be rigid, it is preferred that the device be relatively soft and flexible for purposes of comfort, merely having sufficient rigidity to facilitate insertion. For this purpose various pharmaceutically acceptable natural or synthetic rubber or polymeric materials such as natural rubber, 25 silicone rubber, ethylene vinyl acetate (EVA) copolymers, polyethylene, polypropylene, polycarbonate, polyester, polyurethane, polyisobutylene polymers, and polyoxymethylene polymers such as Delrin® manufactured by Du Pont, for example, are suitable. 30 Polypropylene is particularly useful, especially where the product is to be radiation sterilized.

Although the therapeutic agent and optionally a permeation enhancer may be dispersed throughout the body of the insert 1, it is preferable that the agent be concentrated on the urethra-contacting surfaces of the device in order to permit rapid absorption of the agent and any permeation enhancer. As shown in Figure 1, the shaft 35

2040914

ARC 1747 CIP1

67696-177

7-a

portion 2 of the insert 1 is provided with an agent-containing  
coating 4

which comprises the desired agent dose and, if used, a permeation enhancer, dispersed throughout a rapidly releasing carrier. The coating 4 may be applied to the insert by means of dip coating in an appropriate agent-containing bath, spray coating, heat melt coating, evaporation of a fixed volume of a solution or suspension of the agent in a volatile vehicle or by co-extrusion of an agent-containing layer onto the surface of shaft 2, for example.

To facilitate insertion, coating 4 preferably has lubricating properties and may contain dispersant materials such as PEG, propylene glycol, glycerine, polyvinyl pyrrolidone (PVP), polyvinyl alcohol (PVA), hydroxy alkyl celluloses or cyclodextrins, for example, which are or become slippery upon insertion into the urethra. Materials such as glycerol monolaurate, polyethylene glycol monolaurate, and glycerol monolaurate, for example, may combine permeation enhancing properties with lubricating properties.

To facilitate adherence of the drug coatings to the penile insert, the surfaces to which the coatings are applied may be slightly roughened. Also, to provide a visual indication of complete drug release, the coating, instead of being clear and transparent, can be selected to provide a different visual appearance from that of the uncoated insert. This can be accomplished with the use of dyes or pigments or can be a property of the drug or coating material itself.

In use, the device would be inserted slowly (about 5-10 seconds) into the urethra up to the terminal portion 3 and either maintained in place until the agent is absorbed (about 30-45 seconds) and then slowly removed, or more preferably, particularly with shorter devices (about 2-5 cm in length), the device 1 would be inserted into the urethra up to portion 3 and then, while compressing the penis around shaft 2, gently but firmly rotated and reciprocated to wipe all the agent-containing material from the surface of the device prior to removal.

Referring now to Figure 2, a combination insert/container 10 is shown in which the insert 11 is provided with a tapered agent-carrying shaft portion 12 which terminates in a plug portion 13 which may also be provided with sealing ridges 13a. Plug element 13

terminates in cap portion 14 which may be larger than plug 13 and preferably of a square or other polygonal configuration to make it easy to rotate insert 11 for removal from its container 15.

Container 15 is generally tubular in shape closed at one end and of sufficient length to receive the insert up to contact with cap 14. The interior diameter of container 15 and the exterior diameter of plug 13 with sealing ridges 13a are selected to provide a sliding seal that is sufficient to prevent insert 1 from falling out of the container and the passage of contaminants into the container while permitting removal of the insert with the application of a reasonable force on cap 14.

Referring now to Figure 3, another embodiment of the invention is shown in which the penile insert 20 comprises a shaft portion 22 adapted to be received within the male urethra and a terminal portion 23 in the form of a tubular cap adapted to enclose the glans and, if more agent delivering surface is required, some portion of the shaft of penis 17. The body-contacting surface of insert 20 is provided with an agent-containing coating 24 similar to that described with respect to Figure 1 which coating is applied to the shaft 22 and such other portion of the interior of the terminal portion 23 as is desired. The embodiment of Figure 3 may be used with respect to less potent agents which require an administration rate greater than can be obtained directly through the urethra. Thus the portion of the coating 24 which contacts the glans and the shaft of the penis also provides for the administration of the agent directly through the skin of the penis in addition to the transurethral administration.

In use, the device would be inserted into the urethra 16 and in contact with the skin of penis 17 and maintained in place until all the agent has been released from coating 14. In Figure 3 a constrictive, typically elastic, band 18 is applied around the base of the penis 17 while the insert 20 is in place to constrict the penis and prevent the flow of blood therefrom. This constrictive band can also be used with respect to the embodiments of Figures 1, 2, 4 and 5. It is useful in impotence where it will prevent the flow of blood from corpus cavernosum thereby assisting in the maintenance of the erection and in Peyronie's syndrome where it will cause the

anti-inflammatory drug to remain in the corpus cavernosum for an extended period of time. The constricting bands would not normally be used when the device of this invention is used to treat Priapism where it is desired to increase, rather than retard, the flow of blood from the penis.

Referring now to Figures 4 and 5 another embodiment of this invention is shown for use when the agent is contained in an ointment, paste, suppository, cream or gel formulation of the type described above rather than as a coating on the shaft of an inserter. The dosage inserter/container 25 comprises a container 26 closed at one end and receiving inserter 27 in the other end. Although container 26 can be cylindrical in configuration it is preferred to form container 26 into a more volume efficient flattened configuration such as elliptical or rectangular because there is no need to maintain a large clearance between the exterior of inserter 27 and the interior of container 26, to prevent inadvertent removal of any coating on inserter 27. Inserter 27 comprises a shaft portion 28 having an external configuration similar to that of the inserter shown in Figures 1 and 2 but provided with a longitudinal bore which receives the piston portion 29 of plunger 30, the agent-containing dose 31 in the form of an ointment, paste, suppository, cream or gel having sufficient viscosity to enable it to remain without spillage within the cavity formed between the tip of piston 29 and the bore.

Preferably, means are provided to prevent unintentional activation of plunger 30 which in its simplest form could be a frangible bead or bond which resists relative motion of plunger 30 with respect to shaft portion 28 until a predetermined force is applied. A more positive means is illustrated in Figures 4 and 5 wherein shaft portion 28 terminates in a plug portion 32 configured to form a sliding seal with the interior of container 26. The plug portion 32 terminates in cap portion 33 provided with receptacle means 34 configured to receive plunger 30 when plunger 30 is in a first position and to be incapable of receiving plunger 30 when in a second position and being of sufficient depth to allow displacement of piston 29 over sufficient travel to fully displace dose 31 from the inserter. In Figures 4 and 5 the receptacle 34 is shown as a

slot across cap 33. Plunger 30 is mounted transverse to slot 34 and maintained in this first position by a frangible bond 35. Cap 33 is likewise sealed to container 26 by a similar frangible bond 36.

5 These frangible bonds can be formed by any suitable technique which include adhesive bonding, heat or sonic welding or the application of some form of "shrink wrap" material, for example.

This configuration is readily adaptable to automated filling together with precise control of the quantity of agent dose 31 and provides for positive administration of the desired quantity of drug  
10 at the desired site of application.

Prior to use the device is protected from inadvertent displacement of dose 31 by means of the frangible seal 35 and inadvertent removal of the inserter by means of frangible seal 36.  
15 In use, frangible seal 35 would be broken by rotating plunger 30 from its first position to a second position where it is in alignment with receptacle 34 and frangible seal 36 would be broken to remove the inserter 27 from container 26. The inserter would then be placed into the urethra to the depth of plug 32 and plunger 30 depressed  
20 into receptacle 34 to completely eject dose 31 into the urethra at the desired point of application. The inserter 27 would then be removed leaving the drug load 31 within the urethra.

The materials used to form the inserter/container 25 are the same as those which can be used in fabricating the devices of Figures  
25 1 and 2 for example and when these materials are thermoplastic the formation of the frangible bonds 35 and 36 by sonic fusion is a preferred technique.

Although the configuration shown in Figures 4 and 5 is a preferred configuration, other inserter/container configurations can  
30 be used and any mechanism by which a predetermined quantity of drug can be introduced from the inserter into the urethra at a predetermined depth is suitable for use with this invention. As with the other devices of this invention, the agent in dose 31 can be one or more drugs. However, when a combination of drugs is required to  
35 produce the desired therapeutic effect, it is also possible to sequentially administer separate doses of each individual drug, each of which can

be titrated by the physician and/or patient to produce the desired effect.

5 The embodiments of this invention can either be manufactured under sterile conditions thereby eliminating the need for post manufacturing sterilization or they can be manufactured under non-sterile conditions and then subsequently sterilized by any suitable technique such as radiation sterilization.

10 The penile inserts and injectors of this invention can be manufactured by typical plastic forming and coating process and solvent evaporation known to the art which include molding, extrusion, heat forming, dip coating, spray coating, heat melt coating and solvent evaporation. Although prototype devices of Figure 1 were made from EVA rods which were heat formed by hand into  
15 the configuration of Figure 1 on a hot plate to flatten the exterior end and blunt the interior end, components forming the embodiments of Figures 2 and 4 were made in quantity in conventional injection molding equipment.

20 The molded parts which require coating can be coated by any suitable process. Dip coating, with control of the temperature and viscosity of the bath and the dwell time of the article to be coated in the bath, coupled with air wiping for added precision is capable of producing quite reproducible coatings within the requirements of this invention. Depositing a known volume of a solution or  
25 suspension of the agent/dispersant in a volatile carrier onto the shaft in the presence of a warm air stream also produces coating in a reproducible manner as does the application of a known volume of a melt containing the agent to a cool inserter shaft.

30 PEG based coating formulations are particularly suitable to this invention because they are solid at refrigerator or ambient temperatures but melt at or below body temperature, have lubricating properties and dissolve in the urethra to allow rapid absorption of the active drug therein dispersed. At 70°C the viscosity of a 50-50 blend of PEG 1450 and PEG 400 is such that approximately 100 mg of a  
35 dip mixture was reproducibly left on a 10 cm long by 3.5 mm diameter EVA rod after a single dip.

By varying the molecular weight of the PEGs and/or their ratios and/or the temperature of the bath, the viscosity of the bath and the resultant weight of the coating can be adjusted. For example, a 1:2 weight ratio mixture of PEG 600 and PEG 1000 will have a melting point of about 32°C and could be expected to yield a coating of approximately 50 mg at a bath temperature within the range of about 50°-80°C.

PEG 1450 is available as a flake material at room temperature which on melting and cooling forms a smooth coating on the insert of this invention. At bath temperatures in the range of 60°C to 80°C coatings of about 50 mg can be obtained from a single dip.

As another example, at 70°C, PEG 1450 deposited on the 2 cm of the tip equals about 50 mg. The slower dissolution of the higher molecular weight PEG allows controlled deposit on a limited area. As the system is inserted into the urethra the slower melt of PEG 1450 allows minimal deposition in the distal urethra and maximum at the depth of full insertion.

Coatings formed from the lower molecular weight PEG's need to be stored under refrigeration when high ambient temperatures are anticipated. Coatings formed from PEG 1450, however, were physically stable even when carried exposed to high summer temperatures.

Another approach to forming the desired coating on the shaft of the inserter is to micropipette a known quantity of the agent and dispersant in solution or suspension in a volatile solvent onto the shaft 12 which is maintained in a downwardly inclined position in the presence of a warm air stream to permit rapid evaporation of the solvent before any of the liquid can drop from the shaft. This approach is particularly suitable when both the agent and the dispersant are mutually soluble in the volatile carrier.

As an example, PGE<sub>1</sub> together with a lubricating dispersant such as propylene glycol, PEG, glycerin, PVP, PVA, hydroxyalkyl cellulose or cyclodextrin, for example, would be dissolved in weight ratios of dispersant to agent of 1:1-10:1 in alcohol at a concentration such that a small volume, approximately 10 µl for example, of the alcoholic solution contains the desired dose of the agent. This

2040914

ARC 1747 CIP1

67696-177

13-a

predetermined quantity of solution would be introduced from a micropipette onto the surface of the inserter in

A

the presence of a warm air stream and would evaporate rapidly to form the desired coating. The volume of solution is not critical but should be selected based on the size of the insert and the viscosity of the solution such that a relatively even coating of the solvent solution on the shaft is obtained without any spillage prior to evaporation of the volatile solvent. Melted PEG<sub>1</sub> containing the agent can also be micropipetted in a similar manner onto a cool inserter shaft to provide reproducible doses of single or multiple drugs.

Preferably, the total weight of the coating should be minimized consistent with the maintenance of lubricating properties, and coating weights less than 50 mg are preferred. Similar amounts are also contemplated when the dosage form is in the form of a solution, dispersion, ointment, paste, gel or suppository, for example. At about the 50-100 mg level, the capacity of the urethra to receive the agent containing material and rapidly absorb the agent appears to be reached as some spillage of the coating material was observed.

Once the weight of the agent-containing dose or coating has been selected, the concentration of the agent in the carrier would be appropriately selected to provide the desired total dose within the dosage form or coating.

Unit dosages for PGE<sub>1</sub> are in the range of approximately 10 to 1000  $\mu$ g, 50 to 500  $\mu$ g being preferred, the unit dosages of papaverine are in the range of 1-20 mg, and the unit dosages of phentolamine, prazosin and doxazosin are in the range of about 50 to 1000  $\mu$ g per dose with 100 to 400  $\mu$ g being preferred. It has been observed that combinations of two or more drugs such as PGE<sub>1</sub> and the  $\alpha$ -blockers tend to potentiate the erectile effect thereby permitting efficacy to be obtained at lower doses of both drugs.

If the agent is a combination of drugs they all may be included in one dosage form. However, when the agent comprises more than one drug, it would be preferable to sequentially administer each drug from a dosage form containing only one drug. It is always preferred to use the lowest effective dose in any medical intervention and it is contemplated that the dosage forms of this invention would be provided in various, incremental doses. The

patient would initially titrate himself to the dosage effective for him by using the lowest dosage, and repeating administration until the desired effect is obtained. Thereafter the patient would select an effective incremental dosage that is close to the determined  
5 higher dosage or could continue using multiple lower doses.

The following examples of this invention are provided.

#### EXAMPLE 1

A 3.5 mm EVA (28% VA) rod was formed into an insert having a shaft approximately 10 cm long with a spherical, blunted tip and a  
10 head portion approximately 4 mm thick and 1 cm in diameter on a hot plate. A dipping bath comprising a 50-50 weight blend of PEG 1450 and PEG 400 and sufficient agent to attain the desired concentration in 100 mg of coating was prepared and heated to 70°C. The insert suspended by its head, was dipped into the dipping bath and removed.

15 The total weight of the coating so obtained was approximately 100 mg. Nine inserts having coatings containing approximately 50  $\mu\text{g}$  of  $\text{PGE}_1$  and nine inserts having coatings containing approximately 50  $\mu\text{g}$   $\text{PGE}_1$  and 100  $\mu\text{g}$  prazosin hydrochloride were prepared. When used by an impotent human volunteer, four doses of the 50  $\mu\text{g}$   $\text{PGE}_1$   
20 were required to achieve minimal erection. The dosage forms combining  $\text{PGE}_1$  and prazosin produced a stronger erection in both normal and impotent volunteers at a lower total dose of two units in a shorter period of time. A slight burning sensation in the urethra was observed by the normal volunteer with the devices using the  
25 prazosin hydrochloride but not by the impotent patient. The use of the base form of prazosin rather than the hydrochloride may eliminate the sensation.

#### EXAMPLE 2

A 3 mm diameter EVA (24% VA) rod approximately 10 cm in length  
30 was blunted and rounded on one end and flattened on the other by manipulation on a hot plate. A gelled aqueous coating formulation, comprising 9 gm of 95% ethanol, 1 gm of propylene glycol, 0.2 gm of hydroxypropyl cellulose and 2 mg of  $\text{PGE}_1$  was prepared and dip coated on the shaft of the rod to a total loading of about 500 mg. The  
35 residual ethanol in the coated rod was allowed to evaporate. It is estimated that the loading of  $\text{PGE}_1$  was about 200  $\mu\text{g}/\text{unit}$ . Penile

erection was produced in a normal human subject within ten minutes after the sequential insertion of two rods into the urethra for a total PGE<sub>1</sub> dose of 400 μg.

#### EXAMPLE 3

5 A 3.5 mm EVA (28% VA) rod approximately 10 cm long with rounded tip and flattened head is coated with 500 μg of prazosin base in a PEG blend (1:2 PEG 600:PEG 1000) having a melting point of approximately 32°C. Initial tumescence should be achieved within several minutes after insertion into the male urethra with maximum  
10 effect being produced within about fifteen minutes. Both the intensity and duration of effect will be greater in patients with normal vasculature whose impotence is due to neurologic deficiency. With marked vascular damage a single drug may have incomplete action requiring additional doses or the use of a mixed drug formulation.

#### EXAMPLE 4

15 Penile inserts configured as in Example 3 are coated with a mixture of 20 μg of PGE<sub>1</sub> and 200 μg of doxazosin hydrochloride in the PEG mixture described in Example 3. Patients with moderately severe vascular deficiencies should attain erectile response from this  
20 dosage in several minutes which should be maintained for approximately thirty minutes.

#### EXAMPLE 5

Penile inserts configured as in Example 3 are coated with 100 μg of phenylephrine in approximately 50 mg of the PEG mixture of  
25 Example 3 or approximately 100 μg of adrenalin contained in the PEG mixture of Example 3. Inserts so fabricated are inserted into the urethra of a patient suffering from priapism, due either to pharmacological or other causes. If detumescence is not obtained within approximately five to ten minutes the application will be  
30 repeated at approximately ten minute intervals until detumescence occurs. Small incremental doses are administered in this fashion to prevent systemic overdose when balanced circulation is reestablished.

#### EXAMPLE 6

35 Penile inserts configured as in Example 3 are coated with 100 μg of triamcinolone acetonide in approximately 50 mg of the PEG

mixture of Example 3 and in 50 mg of PEG in the molecular weight range of about 2000-8000 or 50  $\mu$ g of fluocinonide in approximately 50 mg of the PEG mixture of Example 3 and in 50 mg of PEG in the molecular weight range of 2000-8000. Such inserts are inserted daily into the urethra of a patient suffering from Peyronie's disease and allowed to remain in the urethra for approximately twenty minutes to provide the steroid in therapeutic local concentration in the corpus cavernosa. This method eliminates the trauma associated with the local injection of the anti-inflammatory agent which may in itself stimulate the fibrotic process which the therapeutic agent is intended to correct. If improvement is not observed after a course of treatment with single doses, multiple doses can be used for twenty minutes each until a dosage level which is effective can be established.

#### EXAMPLE 7

Penile inserts as in Figure 1 are dip coated with a mixture of PEG 1450 at a temperature of 70°C containing 1% PGE<sub>1</sub>. Dipping to a depth of 2 cm in such a solution leaves a total mass of 50 mg on the distal 2 cm and contains 500  $\mu$ g of PGE<sub>1</sub>. The dipping time is about 1 second and cooling time 3 minutes at room temperature of about 20°C.

This system was stable when carried exposed to summer temperatures in Washington, D.C. and provided adequate lubrication upon insertion when inserted slowly over a period of approximately 5-10 seconds. Approximately 30 seconds after full insertion the system was then slowly removed over 10 seconds, the entire coating had been released into the urethra after this procedure. Erection was obtained after about 15 minutes in a normal male.

#### EXAMPLE 8

A penile insert configured as shown in Figure 2 was injection molded to provide a shaft portion 12 approximately 3 cm in length having a taper from approximately 3 mm diameter at the plug end to approximately 2.5 mm at the tip end was injection molded from polyoxymethylene polymer. PGE<sub>1</sub> together with an equal weight amount of propylene glycol as a lubricant/dispersant were dissolved in ethyl alcohol at a concentration of 400  $\mu$ g PGE<sub>1</sub> per 10  $\mu$ l of solution. Ten  $\mu$ l of this solution were dispensed from a micropipette onto the shaft

portion of the insert, inclined approximately 45° from the vertical, in the presence of warm, flowing air to evaporate the alcohol and provide a thin coating of the PGE<sub>1</sub> in the dispersant on the shaft of the insert. The insert was then placed within its container. The insert was inserted into the urethra and vigorously rotated and reciprocated to wipe the PGE<sub>1</sub> from the surface of the insert for approximately 20 seconds. Similar implants were used by two other subjects and functional erections were obtained in approximately 10 minutes and lasted for approximately 30 minutes. This product exhibited a relatively short shelf life, possibly due to instability of the PGE<sub>1</sub> in the presence of moisture. It would therefore be preferred to manufacture and package the device in a low humidity or nitrogen environment.

#### EXAMPLE 9

A penile insert was manufactured as described in Example 8 except that the drug alprostadil (PGE<sub>1</sub>) was mixed with a gamma type cyclo- dextrin at a ratio of 1 part alprostadil to 4 parts cyclodextran. This product may have a longer shelf life than the product of Example 8.

#### EXAMPLE 10

Inserts configured as shown in Figures 1 and 2 have been evaluated in impotent males in which the impotence is associated with diabetes, post-coronary bypass (vascular insufficiency) and a post-radical prostatectomy, normal aged males and normal healthy males using various vasoactive drugs and combinations thereof. In all instances patients have responded positively although variations in intensity of erection and duration thereof were observed depending on dose, formulation and environment. Analysis of returned used systems showed residual drug loadings of from 0-50% indicating that application technique is important in use of the inserter. The preferred insertion technique which is associated with substantially complete drug removal from the inserter involves slow insertion to the maximum depth over a period of 5-10 seconds, followed by reciprocation and rotation of the inserter over approximately a 2-3 cm length while maintaining pressure on the penis to maintain intimate contact between the urethra and the shaft of the inserter

ARC 1747 CIP1

19

for about 20 seconds and then slow removal of the inserter while maintaining compression on the penis. This technique effectively wipes the surface of the inserter clean and provides for substantially complete agent delivery.

EXAMPLE 11

An inserter configured as in Figure 4 was injection molded to provide a shaft portion approximately 3 cm in length having a taper from approximately 3 mm diameter at the plug end to approximately 2.5 mm at the tip end provided with a 1.5 mm central bore. The plunger is inserted into the central bore to a depth that leaves a 1.5 mm long cavity at the tip. The inserter is inverted and melted PEG 1450 containing 400  $\mu\text{g}$  of alprostadil is cast into the cavity and solidified therein. Upon solidification, a suppository weighing about 2.9  $\mu\text{g}$  and containing about 15% wt alprostadil was formed. Alternatively, a suppository in the form of a 1.5 mm long cylinder of solid PEG 1450 containing 400  $\mu\text{g}$  of alprostadil could be introduced into the shaft either at the tip or moved to the tip of inserter when the plunger is introduced into the 1.5 mm bore. The inserter is molded from polypropylene. The inserter is then placed within a polypropylene container and a sonic bond is formed between the plug portion of the inserter and the container and between the plunger which is mounted crosswise to the slot in the cap. The device may then be radiation sterilized. In use, the bonds between the plunger and the cap and the cap and the container would be broken and the inserter assembly removed from the container, the plunger would be rotated into alignment with the slot in the cap, the shaft of the inserter would be inserted into the penis up to the beginning of the plug and the plunger depressed into the slot to inject the agent load into the urethra. The device would then be removed.

Having thus generally described our invention, it is obvious that various modifications will be apparent to workers skilled in the art which can be made without departing from the scope of this invention which is limited only by the following claims wherein:

35

THE EMBODIMENTS OF THE INVENTION IN WHICH AN EXCLUSIVE PROPERTY OR PRIVILEGE IS CLAIMED ARE DEFINED AS FOLLOWS:

1. An apparatus for use in treating erectile dysfunction comprising:
  - a) a shaft which can be inserted into the urethra of a male patient, and
  - b) a composition including a therapeutic amount of a therapeutic agent which is retained on or in said shaft prior to insertion in the urethra wherein the total amount of said composition does not exceed 100 mg;  
said shaft and said composition being arranged such that, on insertion of the shaft into the urethra, the composition is delivered at a depth of at least 1 cm into the urethra.
2. An apparatus according to claim 1 wherein said composition further comprises a dispersant for the therapeutic agent.
3. An apparatus according to claim 2, wherein said dispersant is selected from the group consisting of pharmaceutically acceptable materials which dissolve, melt or bioerode within the urethra to release the agent.

77971-1

21

4. An apparatus according to any one of claims 1 to 3 further comprising a terminal portion at one end of said shaft, the terminal portion being adapted to prevent complete insertion of the apparatus into the urethra.
- 5 5. An apparatus according to claim 1 wherein the total amount of said composition does not exceed 50 mg.
6. An apparatus according to any one of claims 1 to 5 wherein the length of the shaft is 2 cm or more.
7. An apparatus according to any one of claims 1 to 6  
10 wherein said composition is in the form of a coating covering at least a portion of the shaft.
8. An apparatus according to any one of claims 1 to 6 wherein said shaft comprises a cavity containing said composition at one end of the shaft.
- 15 9. An apparatus according to claim 8 further comprising means for displacing said composition from the cavity into the urethra.
10. An apparatus according to claim 4 wherein said  
terminal portion comprises a tubular cap which is dimensioned  
20 to enclose the outer surface of the glans.

11. An apparatus according to claim 10 wherein the penis-contacting surface of the tubular cap is coated with another composition containing the therapeutic agent, the arrangement being such that, in use, the therapeutic agent on the cap is delivered transdermally to the penis.
12. An apparatus according to claim 4 wherein said terminal portion comprises a plug portion on said shaft having a dimension greater than the diameter of the urethra.
13. An apparatus according to claim 12 further comprising a container for said shaft, said container being closed at one end and of sufficient length to receive said shaft and at least a portion of said plug, the open end of the container being sized to form a sliding seal with the plug portion.
14. An apparatus according to any one of claims 1 to 6 wherein the shaft portion comprises a bore and a piston slidably received within said bore and movable from a first position where said piston forms a dose receiving cavity proximate to the end of the shaft portion containing said composition to a second position where the composition is displaced from the cavity.
15. An apparatus according to claim 14 further comprising a plunger formed on the exterior end of the piston

and receptacle means configured to receive said plunger and being sized to permit movement of the piston from its first position to its second position.

16. An apparatus according to claim 15 wherein the receptacle and plunger are configured such that the plunger and receptacle are in predetermined orientation and further comprising means for releasably maintaining said plunger and receptacle in an orientation different from said predetermined orientation.

17. An apparatus according to any one of claims 1 to 16, wherein the composition comprises a urethral permeation enhancer for the agent.

18. An apparatus according to any one of claims 1 to 17, wherein said erectile dysfunction is impotence and the agent comprises one or more vasodilators.

19. An apparatus according to any one of claims 1 to 17, wherein said dysfunction is priapism and the agent comprises one or more vasoconstrictors.

20. An apparatus according to any one of claims 1 to 17, wherein the dysfunction is Peyronie's syndrome and the agent comprises a material selected from the group consisting of steroidal and nonsteroidal anti-inflammatory agents and

77971-1

77971-1

24

mixtures thereof.

21. An apparatus according to claim 18 wherein said vasodilators are selected from the group consisting of nitrates, long and short acting  $\alpha$ -blockers, calcium blockers, ergot alkaloids, chlorpromazine, haloperidol, yohimbine, natural and synthetic vasoactive prostaglandins and their analogues, vasoactive intestinal peptides, dopamine agonists, opioid antagonists and mixtures thereof.

22. An apparatus according to claim 18 wherein said agent comprises an  $\alpha$ -blocker and a prostaglandin.

23. An apparatus according to claim 18 wherein said agent is selected from 10 to 1000  $\mu\text{g}$  of  $\text{PGE}_1$ , from 50 to 1000  $\mu\text{g}$  of phentolamine, from 50 to 1000  $\mu\text{g}$  of prazosin, from 50 to 1000  $\mu\text{g}$  of doxazosin and mixtures thereof.

24. An apparatus according to any one of claims 1 to 17 and 19, wherein said dysfunction is priapism and said agent is selected from the group consisting of  $\alpha$ -agonists and  $\beta$ -blockers and mixtures thereof.

25. An apparatus according to claim 3 wherein said dispersant comprises polyethylene glycol.

26. An apparatus according to claim 22 wherein said  $\alpha$ -blocker is prazosin.

27. An apparatus for use in treating priapism comprising:

a) a shaft which can be inserted into the urethra of a male patient, and

b) a composition including a therapeutic amount of a therapeutic agent comprising one or more vasoconstrictors, said therapeutic agent is retained on or in said shaft prior to insertion in the urethra wherein the total amount of said composition does not exceed 100 mg;

said shaft and said composition being arranged such that, on insertion of the shaft into the urethra, the composition is delivered at a depth of at least 1 cm into the urethra.

28. An apparatus for use in treating Peyronie's syndrome comprising:

a) a shaft which can be inserted into the urethra of a male patient, and

b) a composition including a therapeutic amount of a therapeutic agent comprising a material selected from the group consisting of steroidal and nonsteroidal anti-inflammatory agents and mixtures thereof, said thereapeutic agent is retained on or in said shaft prior to insertion in the urethra wherein the total amount of said composition does not exceed 100 mg;

said shaft and said composition being arranged such that, on insertion of the shaft into the urethra, the composition is delivered at a depth of at least 1 cm into the urethra.

29. An apparatus for use in treating priapism comprising:

a) a shaft which can be inserted into the urethra of a

77971-1

26

male patient, and

b) a composition including a therapeutic amount of a therapeutic agent comprising  $\alpha$ -agonists and  $\beta$ -blockers and mixtures thereof, said therapeutic agent is retained on or in said shaft prior to insertion in the urethra wherein the total amount of said composition does not exceed 100 mg;

said shaft and said composition being arranged such that, on insertion of the shaft into the urethra, the composition is delivered at a depth of at least 1 cm into the urethra.

30. A commercial package comprising an apparatus according to any one of claims 1 to 27 together with instructions for use of the apparatus in urethral administration of the composition to treat erectile dysfunction.

SMART & BIGGAR  
OTTAWA, CANADA

PATENT AGENTS

FIG. 1

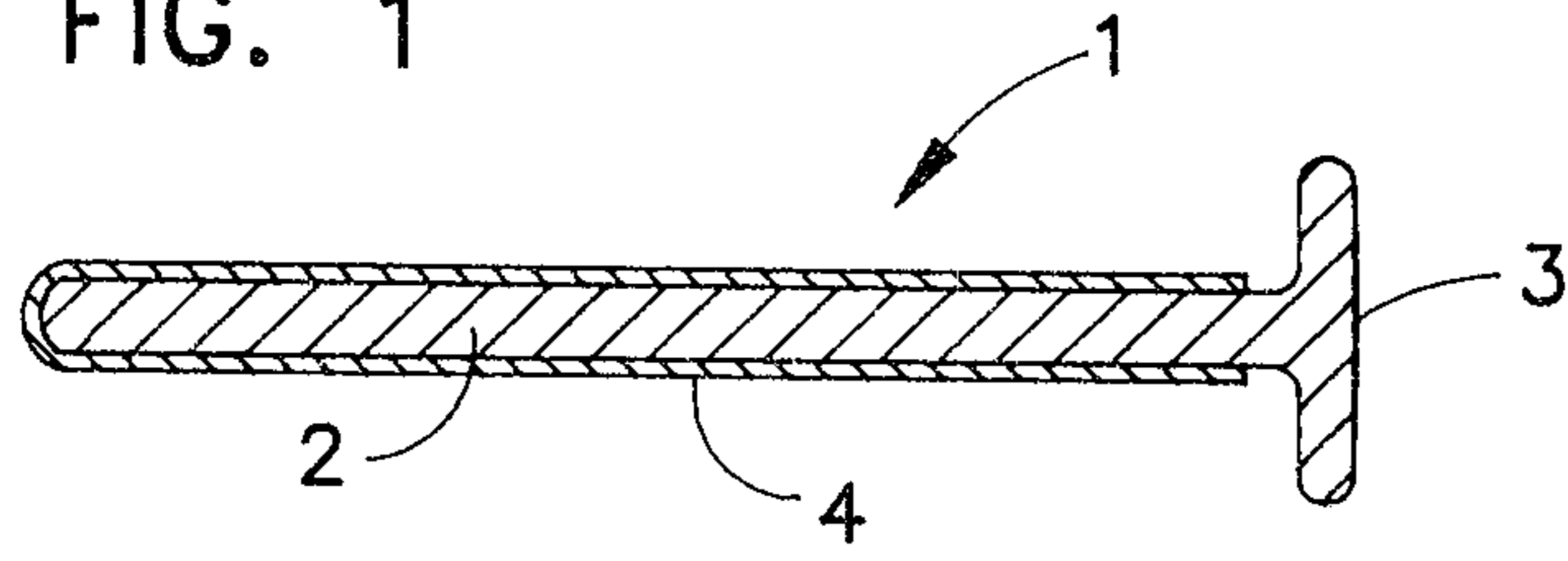

FIG. 2

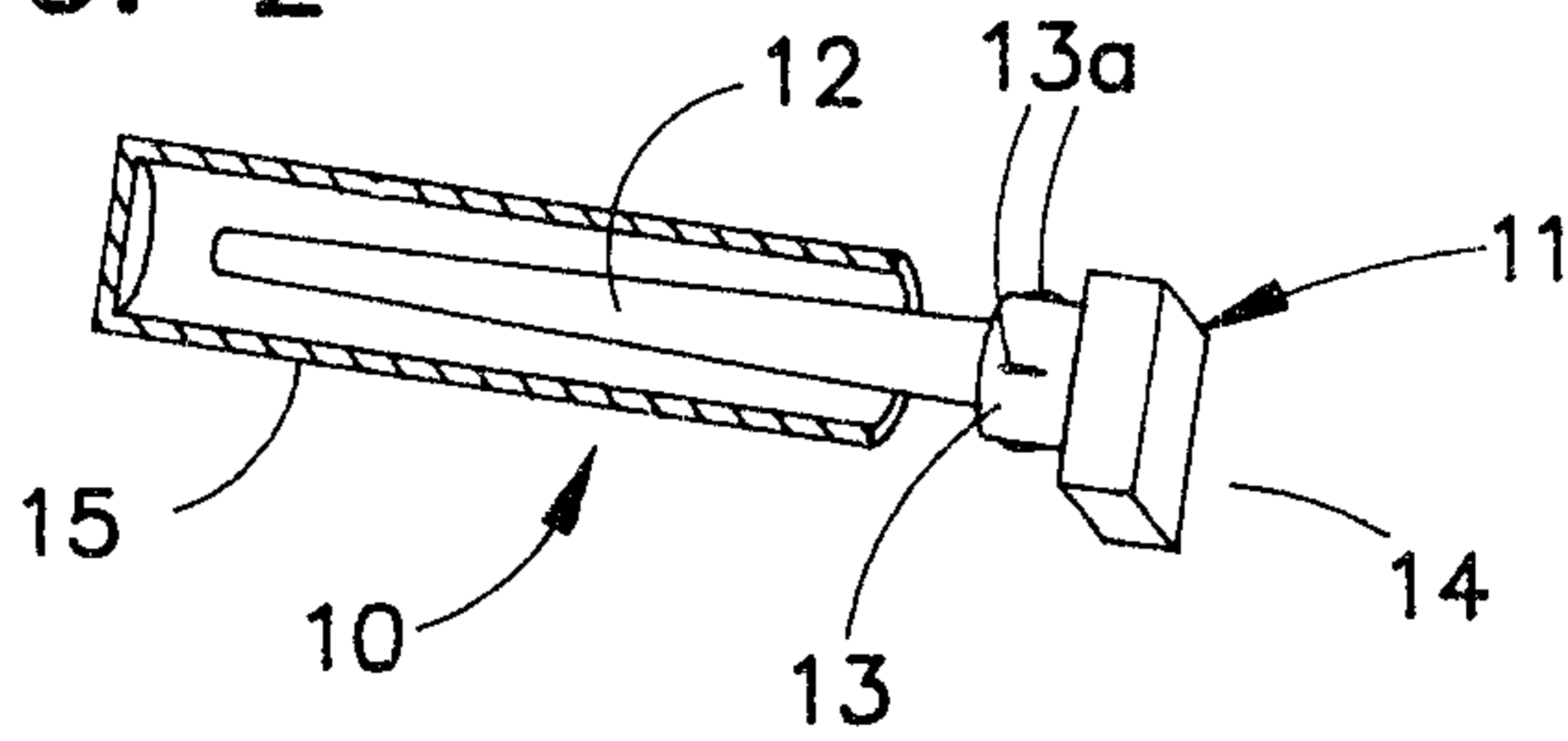

FIG. 3

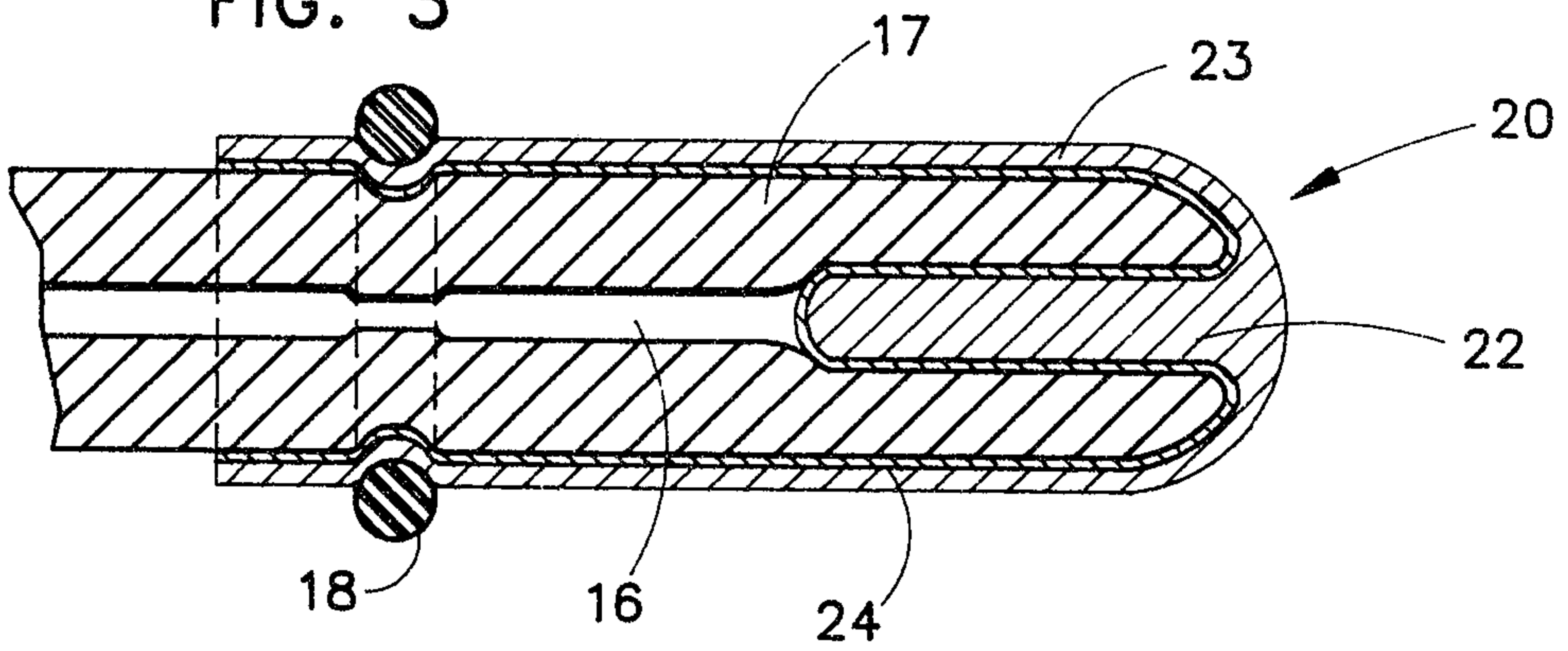

FIG. 4

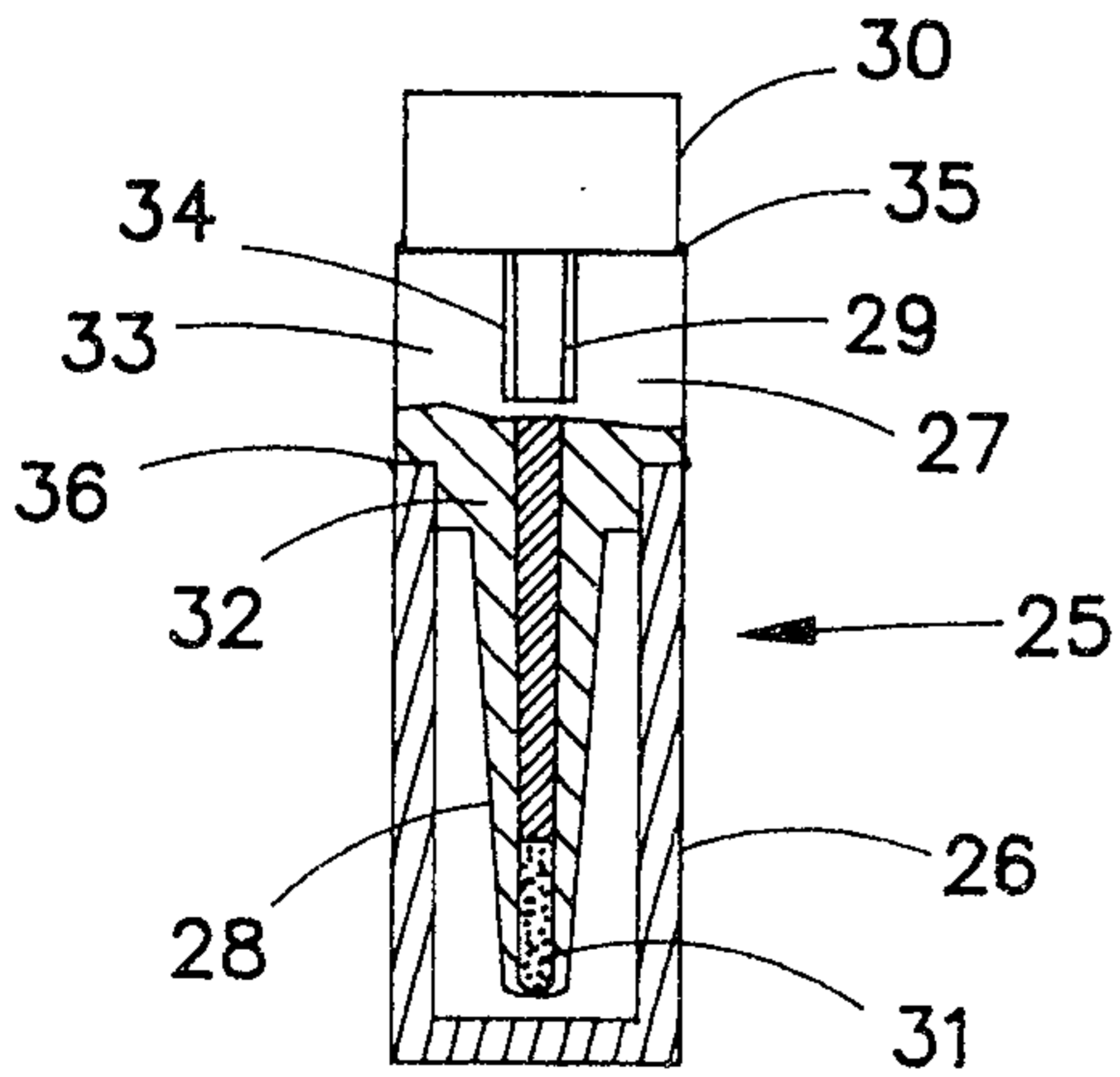
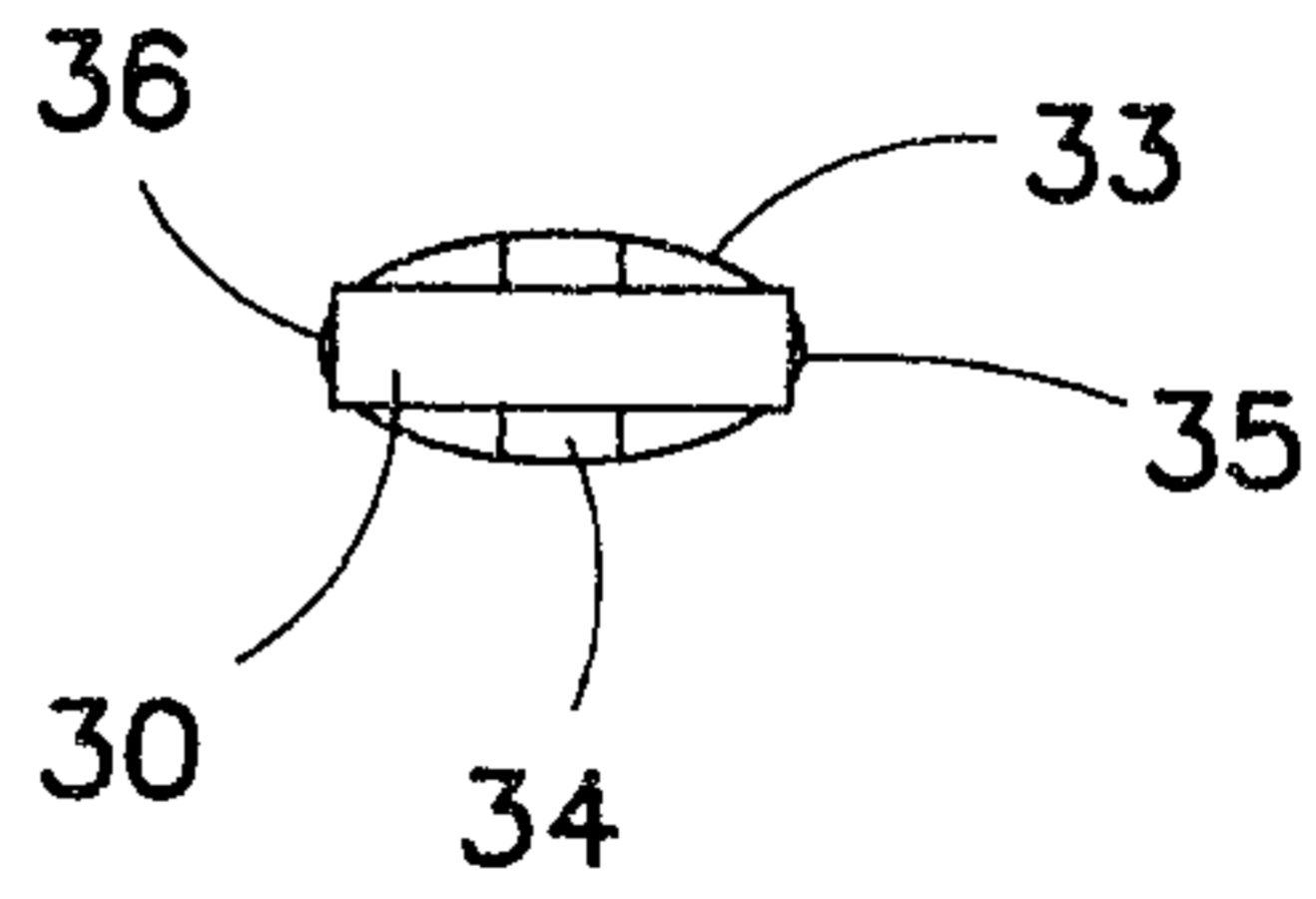

FIG. 5



Patent Agent  
Smart & Co.

