

(19) World Intellectual Property Organization
International Bureau



(43) International Publication Date
9 September 2011 (09.09.2011)

(10) International Publication Number
WO 2011/109220 A2

- (51) International Patent Classification: Not classified
- (21) International Application Number: PCT/US2011/026070
- (22) International Filing Date: 24 February 2011 (24.02.2011)
- (25) Filing Language: English
- (26) Publication Language: English
- (30) Priority Data: 61/309,783 2 March 2010 (02.03.2010) US
- (72) Inventor; and
- (71) Applicant : ALFONSO, Jorge, R. [US/US]; 43 Rainey Street Apartment 2803, Austin, TX 78701 (US).
- (74) Agent: VOIGT, Robert, A., Jr.; Winstead PC, P.O. Box 50784, Dallas, TX 75201 (US).
- (81) Designated States (unless otherwise indicated, for every kind of national protection available): AE, AG, AL, AM, AO, AT, AU, AZ, BA, BB, BG, BH, BR, BW, BY, BZ, CA, CH, CL, CN, CO, CR, CU, CZ, DE, DK, DM, DO,

DZ, EC, EE, EG, ES, FI, GB, GD, GE, GH, GM, GT, HN, HR, HU, ID, IL, IN, IS, JP, KE, KG, KM, KN, KP, KR, KZ, LA, LC, LK, LR, LS, LT, LU, LY, MA, MD, ME, MG, MK, MN, MW, MX, MY, MZ, NA, NG, NI, NO, NZ, OM, PE, PG, PH, PL, PT, RO, RS, RU, SC, SD, SE, SG, SK, SL, SM, ST, SV, SY, TH, TJ, TM, TN, TR, TT, TZ, UA, UG, US, UZ, VC, VN, ZA, ZM, ZW.

(84) Designated States (unless otherwise indicated, for every kind of regional protection available): ARIPO (BW, GH, GM, KE, LR, LS, MW, MZ, NA, SD, SL, SZ, TZ, UG, ZM, ZW), Eurasian (AM, AZ, BY, KG, KZ, MD, RU, TJ, TM), European (AL, AT, BE, BG, CH, CY, CZ, DE, DK, EE, ES, FI, FR, GB, GR, HR, HU, IE, IS, IT, LT, LU, LV, MC, MK, MT, NL, NO, PL, PT, RO, RS, SE, SI, SK, SM, TR), OAPI (BF, BJ, CF, CG, CI, CM, GA, GN, GQ, GW, ML, MR, NE, SN, TD, TG).

Published: — without international search report and to be republished upon receipt of that report (Rule 48.2(g))

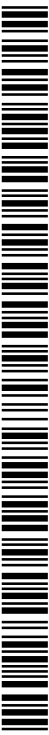

WO 2011/109220 A2

(54) Title: REBAR SUPPORT RINGS

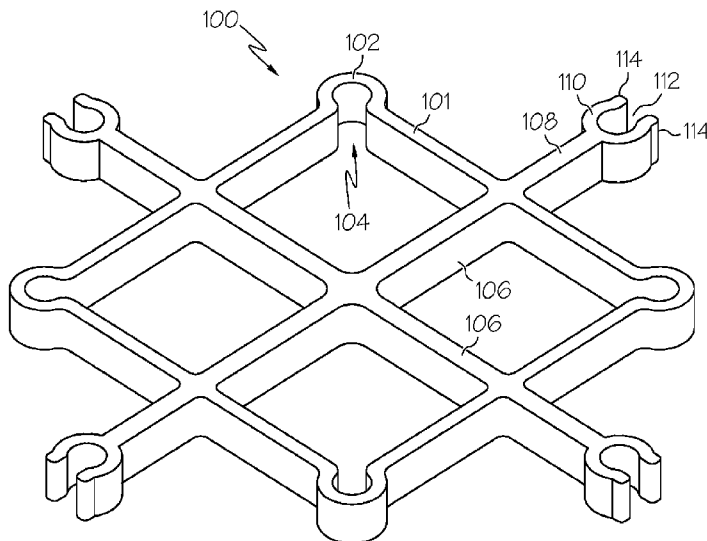

FIG. 1

(57) Abstract: Structures for supporting and aligning a reinforcing bar ("rebar") during the construction of a column, beam or other structure in which the rebar is laid out in parallel to an axis. One such structure includes a support structure having a square ring, where the corners of the square ring include a rebar receptacle configured to receive a reinforcing bar. The rebar receptacle includes an opening through which the reinforcing bar can be inserted, where the opening is configured to allow the reinforcing bar to enter the rebar receptacle and further configured to retain the reinforcing bar after the reinforcing bar has been seated due to the width of the opening being less than a diameter of the reinforcing bar.

REBAR SUPPORT RINGS

CROSS REFERENCE TO RELATED APPLICATIONS

[0001] This application is related to the following commonly owned co-pending U.S. Patent Application:

Provisional Application Serial No. 61/309,783, "Rebar Support Rings," filed March 2, 2010, and claims the benefit of its earlier filing date under 35 U.S.C. §119(e).

TECHNICAL FIELD

[0002] The present invention relates to reinforcing bars ("rebars") used in construction, and more particularly to providing a structure for supporting and aligning a rebar during the construction of a column, beam or other structure in which the rebar is laid out parallel to an axis.

BACKGROUND

[0003] Concrete is commonly used as a construction material because of its relatively low cost. Concrete is very strong in compression, but weak in tension. To increase the tensile strength of concrete, steel reinforcement bars ("rebars") are added. For foundations, road work or other flat constructions, the rebar is often laid out in a grid pattern beneath the surface of the construction. To hold the rebar together in a grid, the bars are tied together where they intersect.

[0004] Various codes specify where the rebar must be placed. For example, the American Concrete Institute (ACI) in Section 318 of their code specifies that the rebar in a slab-on-grade foundation must be placed at the midpoint depth of the foundation. Thus, for example, in a four inch foundation slab, the rebar grid would normally be placed at a depth of approximately two inches. Consequently, the grid must be elevated off the ground to the desired position before concrete is poured. In many cases, concrete laborers use stones, pieces of broken bricks or materials to elevate the grid. This can cause the grid to be uneven or sag when the concrete is poured.

[0005] For concrete pillars and beams, the rebar is tied to a set of wooden frames and placed in a mold. The concrete is then poured into the mold to form the pillar, beam or other construction. However, this method suffers many disadvantages. First, it is difficult to align the rebar in

parallel around the frames. Second, the frames often break or shift when the concrete is poured, causing the rebar to become misaligned. This reduces the tensile strength of the construction.

BRIEF SUMMARY

[0006] In one embodiment of the present invention, a structure for supporting and aligning a reinforcing bar comprises a support structure, where the corners of the support structure comprise a rebar receptacle configured to receive a reinforcing bar. The rebar receptacle comprises an opening through which the reinforcing bar can be inserted, where the opening is configured to allow the reinforcing bar to enter the rebar receptacle and further configured to retain the reinforcing bar after the reinforcing bar has been seated due to the width of the opening being less than a diameter of the reinforcing bar.

[0007] In another embodiment of the present invention, a structure for supporting and aligning a reinforcing bar comprises a support structure having a circular ring. The structure further comprises arms extending outwardly from the circular ring. In addition, the structure comprises a bar receptacle disposed at an end of one of the arms, where the bar receptacle comprises fingers that are shaped so that the reinforcing bar can be pressed into the bar receptacle. The fingers can close after the reinforcing rebar enters the bar receptacle so that a width of an opening of the bar receptacle is smaller than a diameter of the reinforcing bar thereby retaining the reinforcing bar. The bar receptacle acts as a snap-fit based on a spring action of the structure to provide feedback to a user when the user inserts the reinforcing bar.

[0008] In another embodiment of the present invention, a structure for supporting and aligning a reinforcing bar comprises a support structure having a circular ring. The structure further comprises arms extending outwardly from the circular ring. In addition, the structure comprises a bar receptacle disposed at an end of one of the arms, where the bar receptacle comprises a closed circle configuration configured to retain the reinforcing bar.

[0009] The foregoing has outlined rather generally the features and technical advantages of one or more embodiments of the present invention in order that the detailed description of the present invention that follows may be better understood. Additional features and advantages of the present invention will be described hereinafter which may form the subject of the claims of the present invention.

BRIEF DESCRIPTION OF THE SEVERAL VIEWS OF THE DRAWINGS

[0010] A better understanding of the present invention can be obtained when the following detailed description is considered in conjunction with the following drawings, in which:

[0011] Figure 1 illustrates a support structure having a square ring configured in accordance with an embodiment of the present invention;

[0012] Figure 2 illustrates an embodiment of the present invention of a support structure with outwardly extending arms and feet;

[0013] Figures 3A-3B illustrate a structure having a rectangular ring with bar receptacles at each corner in accordance with an embodiment of the present invention;

[0014] Figure 4 illustrates a structure having a rectangular ring with receptacles at each corner and receptacles spaced between the corners in accordance with an embodiment of the present invention;

[0015] Figure 5 illustrates a structure having a circular ring configured in accordance with an embodiment of the present invention;

[0016] Figure 6 illustrates another embodiment of the present invention of a structure having a ring;

[0017] Figure 7 illustrates a structure similar to the structure of Figure 6 but includes arms and feet in accordance with an embodiment of the present invention;

[0018] Figures 8A-8B illustrate providing support for a rebar in a column in accordance with an embodiment of the present invention.

DETAILED DESCRIPTION

[0019] Embodiments described herein provide a structure for supporting and aligning a rebar, and, in particular, supporting and aligning the rebar during the construction of a column, beam or other structure in which the rebar is laid out parallel to an axis. Embodiments described herein provide a support structure that retains the parallel pieces of the bar about an axis in a desired shape.

[0020] Embodiments described herein can provide a support structure having a generally square, rectangular, circular or other shaped ring that has bar receptacles spaced as needed along the ring. The bar receptacles, according to one embodiment, can comprise sidewalls that at least partially define a bar retaining portion and an opening to the bar retaining portion. According to one embodiment, the wall can be radiused about the bar retaining portion. The support structure can include cross-arms to provide support to the ring and arms that extend outward from the ring. Bar receptacles can be placed as desired on the cross-arms or outwardly extending arms. Arms of the ring can connect adjacent bar receptacles. According to one embodiment, the support structure can be formed of a unitary piece of material.

[0021] The ring can be configured so that each opening to a bar receptacle will widen as a bar is pushed into the opening and close as the bar seats in the bar retaining portion. According to one embodiment, the bar receptacles can be snap-on receptacles that provide auditory or tactile feedback to a user.

[0022] Figure 1 is a diagrammatic representation of one embodiment of a support structure 100 having a square ring 101 in accordance with an embodiment of the present invention. The corners of the square 101 include rebar receptacles 102 to receive the rebar. Each receptacle can include an opening 104 through which the rebar can be inserted. Structure 100 can be formed of a resilient plastic or other material so that as the rebar is pushed into opening 104, opening 104 opens to allow the rebar to enter receptacle 102. As the rebar is inserted in receptacle 102, opening 104 widens due to the elasticity of structure 100. When the rebar is sufficiently seated, the resiliency of structure 100 causes opening 104 to close so that the width of opening 104 is less than the diameter of the rebar, thereby retaining the rebar in receptacle 102. The receptacles

102 can act as a snap-fit based on the spring action of square 101. The snap-on connection can provide audible or tactile feedback to the user when the user inserts the rebar.

[0023] Support structure 100 can include one or more arms 106 extending across ring 101 to provide support to the sides of square 101. Additionally, structure 100 can include outwardly extending arms 108. According to one embodiment, arms 108 can be aligned with arms 106. Additional bar receptacles 110 can be located at the ends of arms 106. Bar receptacles 110 can include curved fingers 114 forming opening 112. As a bar presses against fingers 114, fingers 114 can spread apart so that the bar can enter the receptacle. Due to the resiliency of fingers 114, fingers 114 can come back together when the bar is seated so that opening 112 is less than the width of the bar.

[0024] While, in the embodiment of Figure 1, rebar receptacles 102 are shown at the corners of square 101, rebar receptacles 102 can be located at any point on square 101, arms 106 or arms 108. Different receptacles can be sized to fit different sizes of rebar, plumbing or electrical conduit. Additionally, some or all of the receptacles can be shaped so that the receptacles open outward from square 101. In one embodiment, structure 100 does not have outwardly extending arms.

[0025] Figure 2 is a diagrammatic representation of another embodiment of the present invention of a support structure 100 that is similar to the embodiment of Figure 1. The embodiment of Figure 2 includes outwardly extending arms 108 and feet 114. Feet 114, according to one embodiment, can be positioned so that the feet abut the inner surface of a mold into which the concrete will be poured. Also, as illustrated in Figure 2, bar receptacles 116 can be placed along arms 108. Figure 2 also illustrates that square 101 can include bar receptacles 118 at any point along square 101.

[0026] Figures 3A and 3B are a diagrammatic representation of another embodiment of the present invention of a structure 120 having a rectangular ring 121 with bar receptacles 122 at each corner. Structure 120 can be formed of a resilient plastic or other material so that as the rebar is pushed into opening 124, opening 124 opens to allow the rebar to enter receptacle 122. When the rebar is sufficiently inserted in receptacle 122, the resilience of structure 120 can cause opening 124 to close so that opening 124 is less than the diameter of the rebar, thereby retaining

the rebar in receptacle 122. Rectangular ring 121 can also include receptacles 126 to receive the rebar spaced between the corners. Figures 3a and 3b include outwardly extending arms 132 and feet 134. Feet 134, according to one embodiment, can be positioned so that feet 134 abut the inner surface of a mold into which the concrete will be poured. Bar receptacles can be placed along arms 132. Additional bar receptacles 135 can be disposed along arms 132.

[0027] Figure 4 is a diagrammatic representation of another embodiment of the present invention of a structure 120 having a rectangular ring 121 with receptacles 122 at each corner and receptacles 126 spaced between the corners. In the embodiment of Figure 4, receptacles 126 include fingers 138 that extend inward relative to arms 127. Fingers 138 have surfaces 140 that angle or curve away from each other so that when a bar is pressed against surfaces 140, fingers 138 will open so that the bar can enter receptacle 126. Because of the resilience of fingers 138, the opening to receptacle 126 will close so that the opening is smaller than the width of the bar, thereby retaining the bar in receptacle 126.

[0028] Figure 5 is a diagrammatic representation of a structure 150 having a circular ring 151 in accordance with an embodiment of the present invention. Arms 152 extend outwardly from circular ring 151. Bar receptacles 154 are disposed at the ends of arms 152. Receptacles 154 can include fingers 158 that are shaped so that the rebar can be pressed into receptacles 154. Due to the elasticity of structure 150, fingers 158 will open so that the rebar can enter receptacle 154. Fingers 158 can then close so that the widths of openings 160 are smaller than the diameter of the rebar, thereby retaining the rebar. Receptacles 154 can act as a snap-fit based on the spring action of structure 150 to provide feedback to the user when the user inserts the rebar. Receptacles 154 can have a variety of sizes to accommodate rebar, plumbing, conduit or other elongated bars.

[0029] Arms 161 of an outer circular ring can join adjacent receptacles to provide lateral support to each receptacle. Cross-arms 162 can provide support to ring 151. Bar receptacles can be disposed on inner ring 151, arms 152, arms 161 or be otherwise disposed about structure 150 in desired positions.

[0030] Figure 6 is a diagrammatic representation of yet another embodiment of the present invention of a structure 180 comprising a ring 181. Bar receptacles 182 are disposed about ring

181. Receptacles 182 can include fingers 188 configured to spread apart as the rebar enters receptacle 182. When the rebar is sufficiently seated in receptacle 182, fingers 188 can come back together so that the opening 190 is smaller than the width of the rebar. Receptacles 182 can act as a snap-fit based on the spring action of ring 181 and fingers 188 to provide feedback to the user when the user inserts the rebar. Arms 190 can provide radial support to ring 181. Arms 183 can join adjacent receptacles.

[0031] Figure 7 is a diagrammatic representation of another embodiment of the present invention of a structure 200 that is similar to structure 180, but includes arms 202 and feet 204. Feet 204 can be positioned to abut the inner surface of a mold. Arms 202 can be aligned with cross-arms 206 for greater strength. Figure 7 also illustrates that rebar receptacles 208 can be positioned on arms 202.

[0032] According to one embodiment, a column can be constructed as follows. A shell or mold can be fabricated that provides the shape of the column. An appropriate sized support structure can be selected. Rebar and other elongated bars can be snapped into a series of support structures. The support structures and rebar can be placed in the mold with the feet of the support structures contacting the inner side of the mold. Concrete can then be poured in the mold.

[0033] Figures 8A and 8B are diagrammatic representations of one embodiment of the present invention of providing support for a rebar in a column. Referring to Figures 8A and 8B, a mold 300 provides the shape for a column. Rebar 302 is coupled to a series of support structures 304 that retain rebar 302. The feet 306 of the support structures 304 abut the walls of the mold to provide an appropriate offset between the surface of the column and rebar 302. According to one embodiment, support structures 304 can comprise support structures that allow rebar 302 to snap-on the support structure.

[0034] While embodiments above have been discussed in the context of a rebar, embodiments of the present application can be used with graphite tubing, glass tubing, plumbing, conduit, wire mesh, or any other elongated bar. In the various embodiments, bar receptacles can be placed at any position as needed or desired and can face inwardly and/or outwardly along the support structure. The receptacles of a particular support structure can have a variety of sizes to

accommodate different sizes of bars. Moreover, according to one embodiment, the center of a support structure can provide a passage for plumbing, conduit or other elongated bar and can include a snap-on fitting or other receptacle to retain a bar. According to one embodiment, the support structures can be formed of a unitary piece of resilient plastic.

[0035] Embodiments described herein provide advantages over existing methods because it is easier to couple rebar in a desired shape. Embodiments described herein provide another advantage by being more stable when concrete is poured, thereby increasing the integrity of the final construction. Embodiments described herein provide yet another advantage by increasing the accuracy of alignment of the bars.

[0036] As used herein, the terms “comprises,” “comprising,” “includes,” “including,” “has,” “having” or any other variation thereof, are intended to cover a non-exclusive inclusion. For example, a process, product, article, or apparatus that comprises a list of elements is not necessarily limited to only those elements but may include other elements not expressly listed or inherent to such process, article, or apparatus. Further, unless expressly stated to the contrary, “or” refers to an inclusive or and not to an exclusive or. For example, a condition A or B is satisfied by any one of the following: A is true (or present) and B is false (or not present), A is false (or not present) and B is true (or present), and both A and B are true (or present).

[0037] Additionally, any examples or illustrations given herein are not to be regarded in any way as restrictions on, limits to, or express definitions of, any term or terms with which they are utilized. Instead these examples or illustrations are to be regarded as being described with respect to one particular embodiment and as illustrative only. Those of ordinary skill in the art will appreciate that any term or terms with which these examples or illustrations are utilized encompass other embodiments as well as implementations and adaptations thereof which may or may not be given therewith or elsewhere in the specification and all such embodiments are intended to be included within the scope of that term or terms. Language designating such non-limiting examples and illustrations includes, but is not limited to: “for example,” “for instance,” “e.g.,” “in one embodiment,” and the like.

[0038] Further modifications and alternative embodiments of various aspects of the disclosure will be apparent to those skilled in the art in view of this description. Accordingly, this

description is to be construed as illustrative only and is for the purpose of teaching those skilled in the art the general manner of carrying out the disclosure. It is to be understood that the forms of the disclosure shown and described herein are to be taken as the presently preferred embodiments. Elements and materials may be substituted for those illustrated and described herein, parts and processes may be reversed, and certain features of the disclosure may be utilized independently, all as would be apparent to one skilled in the art after having the benefit of this description of the disclosure. Any dimensions provided are provided by way of example only and not limitation. Furthermore, embodiments of support structures can include other geometric or arbitrary shapes. Changes may be made in the elements described herein without departing from the spirit and scope of the disclosure.

CLAIMS:

1. A structure for supporting and aligning a reinforcing bar comprising:
a support structure, wherein corners of said support structure comprise:
a rebar receptacle configured to receive a reinforcing bar, wherein said rebar receptacle comprises an opening through which said reinforcing bar can be inserted, wherein said opening is configured to allow said reinforcing bar to enter said rebar receptacle and further configured to retain said reinforcing bar after said reinforcing bar has been seated due to the width of said opening being less than a diameter of said reinforcing bar.
2. The structure as recited in claim 1, wherein said support structure is configured as a square ring.
3. The structure as recited in claim 2 further comprising:
one or more arms extending across said square ring to provide support to sides of said square ring.
4. The structure as recited in claim 3 further comprising:
one or more additional rebar receptacles located at one or more ends of said one or more arms.
5. The structure as recited in claim 4, wherein each of said one or more additional rebar receptacles comprises curved fingers forming an opening to receive and retain a second reinforcing bar.
6. The structure as recited in claim 3 further comprising:
one or more feet located at one or more ends of said one or more arms.
7. The structure as recited in claim 6 further comprising:
one or more additional rebar receptacles located along said one or more arms.
8. A structure for supporting and aligning a reinforcing bar comprising:
a support structure having a circular ring;
arms extending outwardly from said circular ring; and

a bar receptacle disposed at an end of one of said arms, wherein said bar receptacle comprises fingers that are shaped so that said reinforcing bar can be pressed into said bar receptacle, wherein said fingers can close after said reinforcing rebar enters said bar receptacle so that a width of an opening of said bar receptacle is smaller than a diameter of said reinforcing bar thereby retaining said reinforcing bar, wherein said bar receptacle acts as a snap-fit based on a spring action of said structure to provide feedback to a user when said user inserts said reinforcing bar.

9. A structure for supporting and aligning a reinforcing bar comprising:
a support structure having a circular ring;
arms extending outwardly from said circular ring; and

a bar receptacle disposed at an end of one of said arms, wherein said bar receptacle comprises a closed circle configuration configured to retain said reinforcing bar.

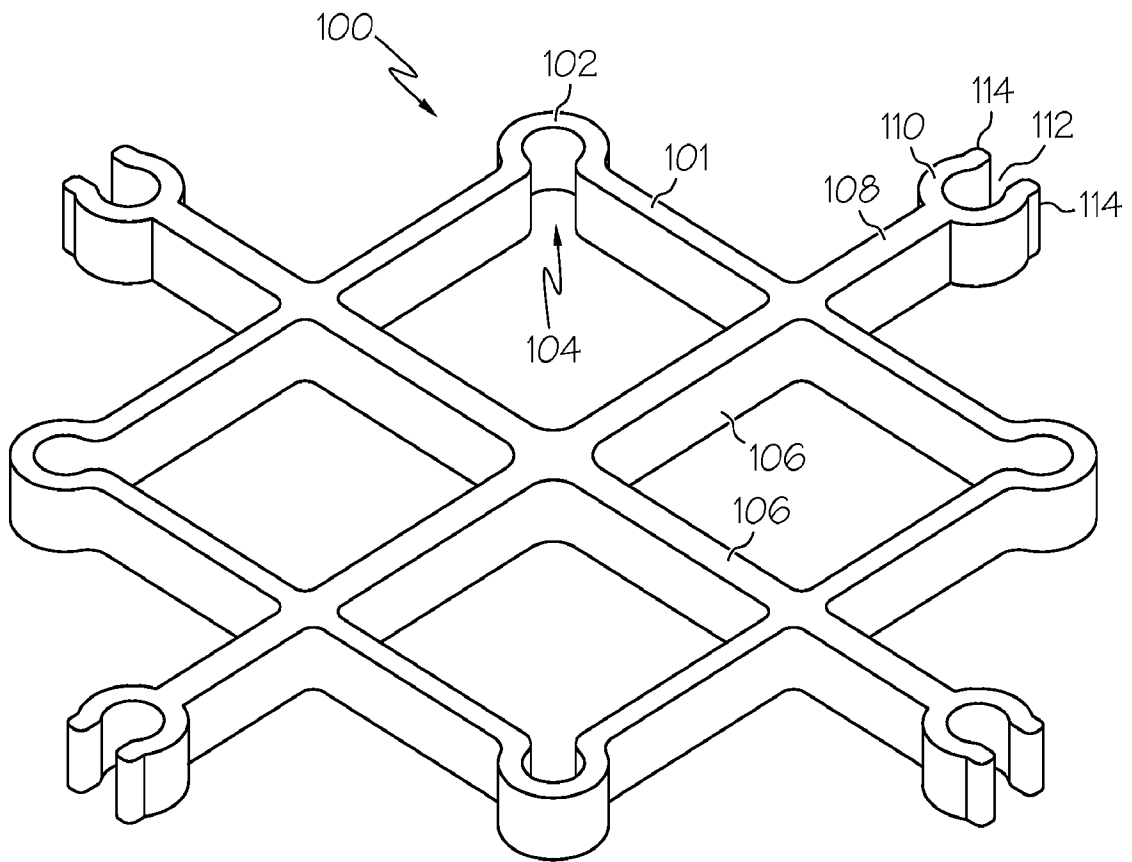

FIG. 1

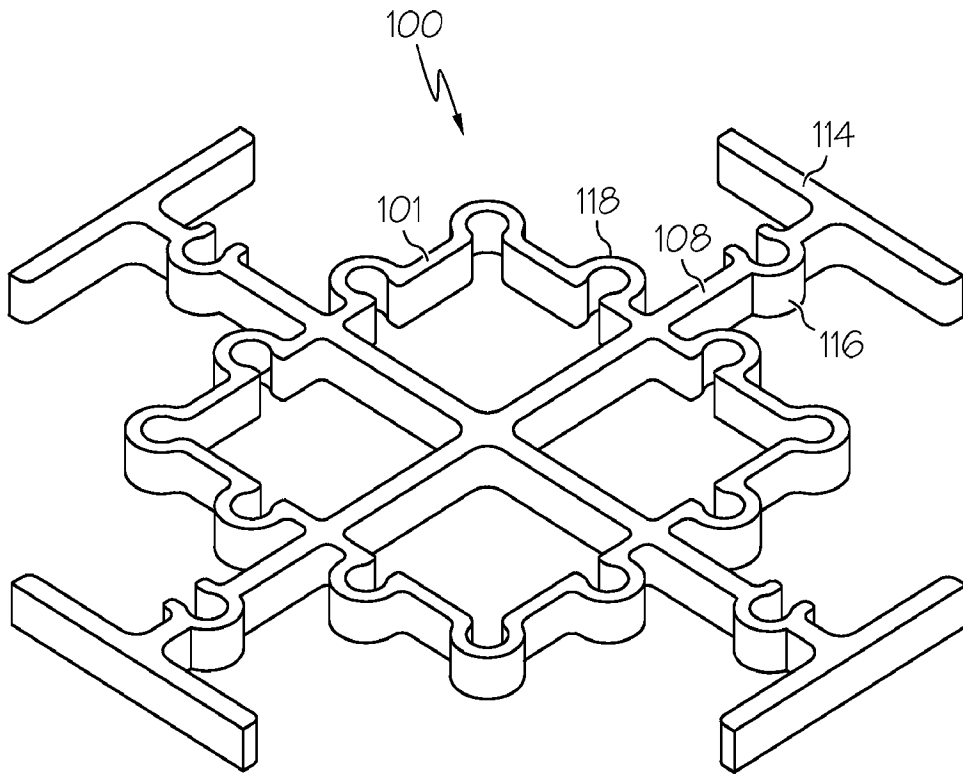

FIG. 2

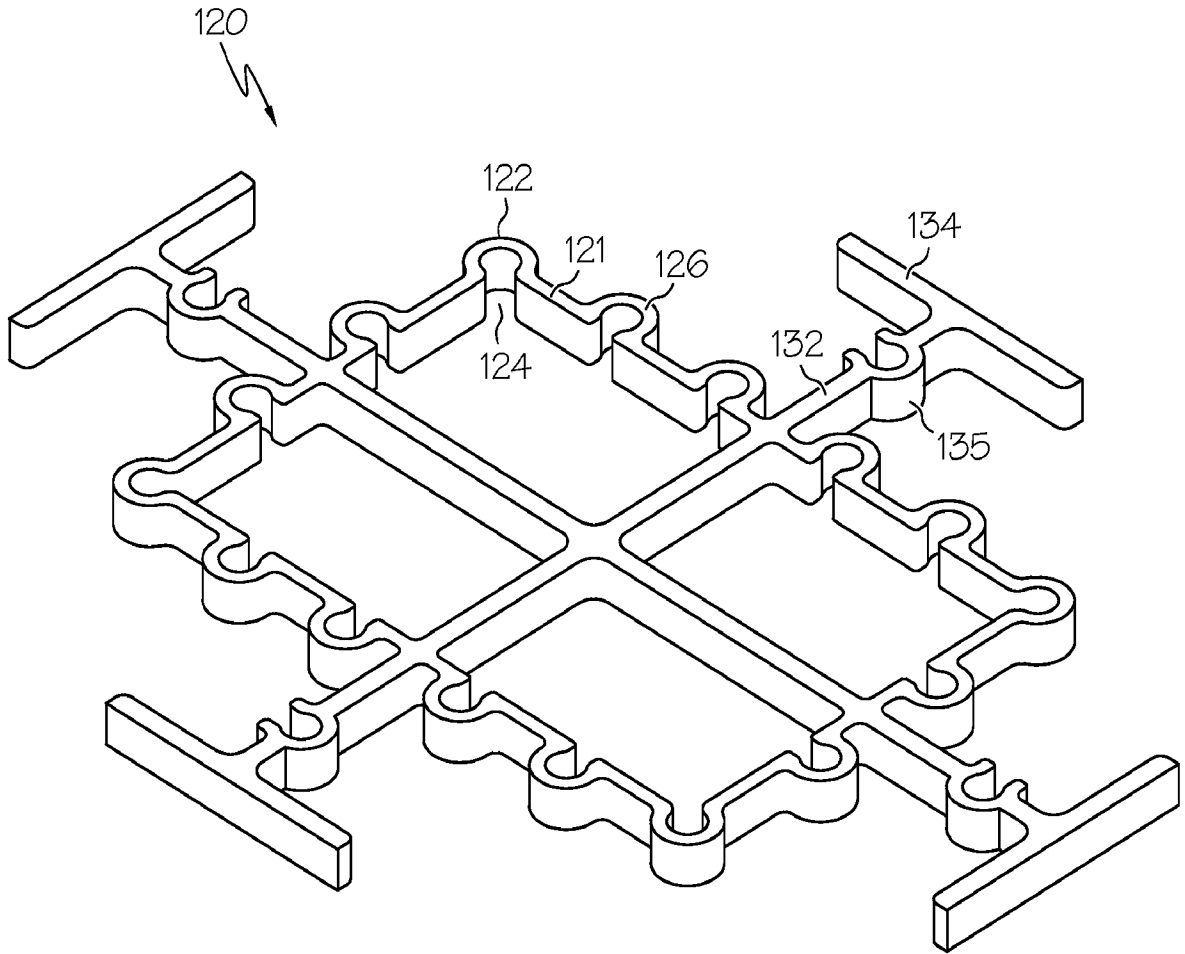

FIG. 3A

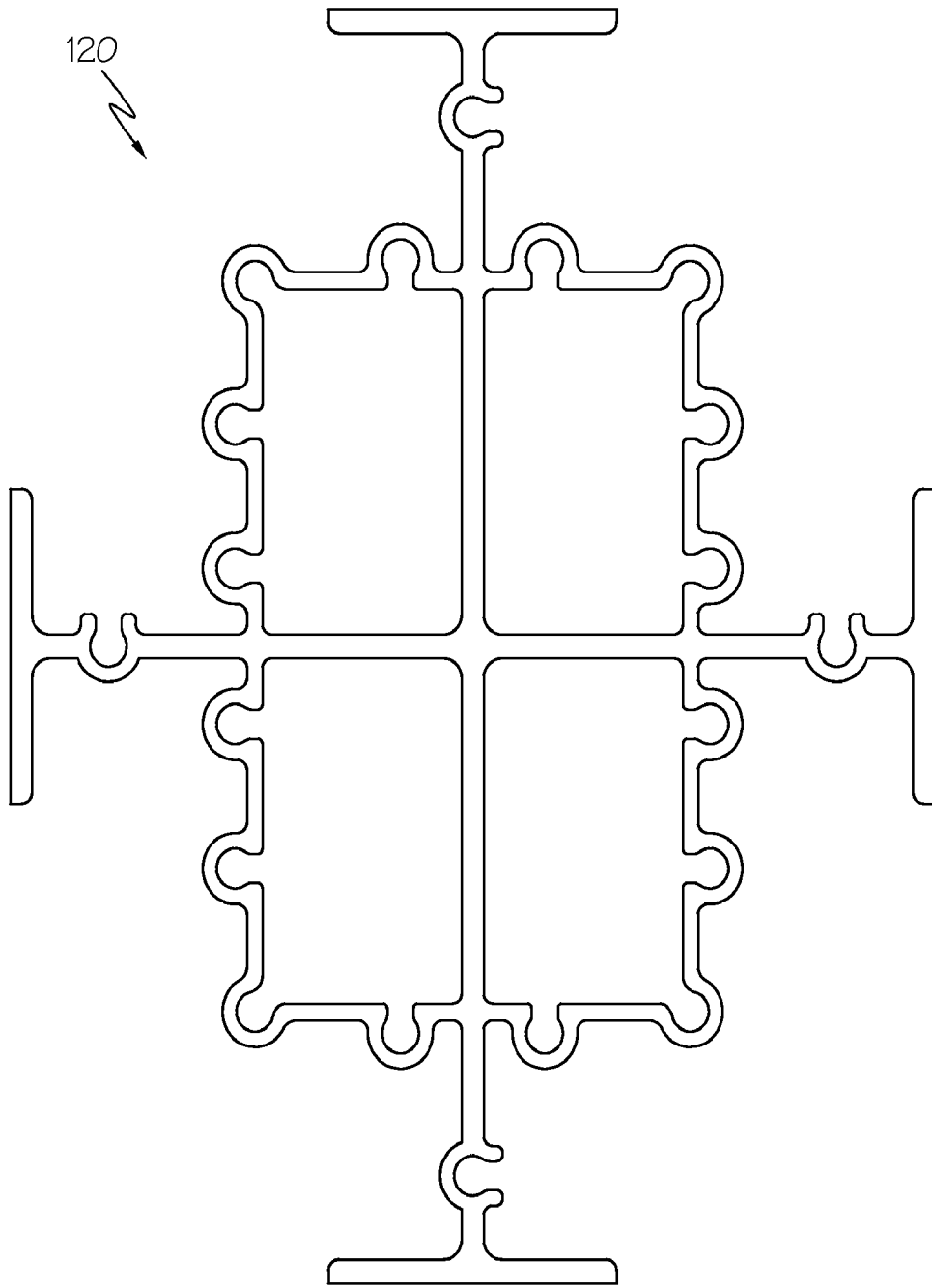

FIG. 3B

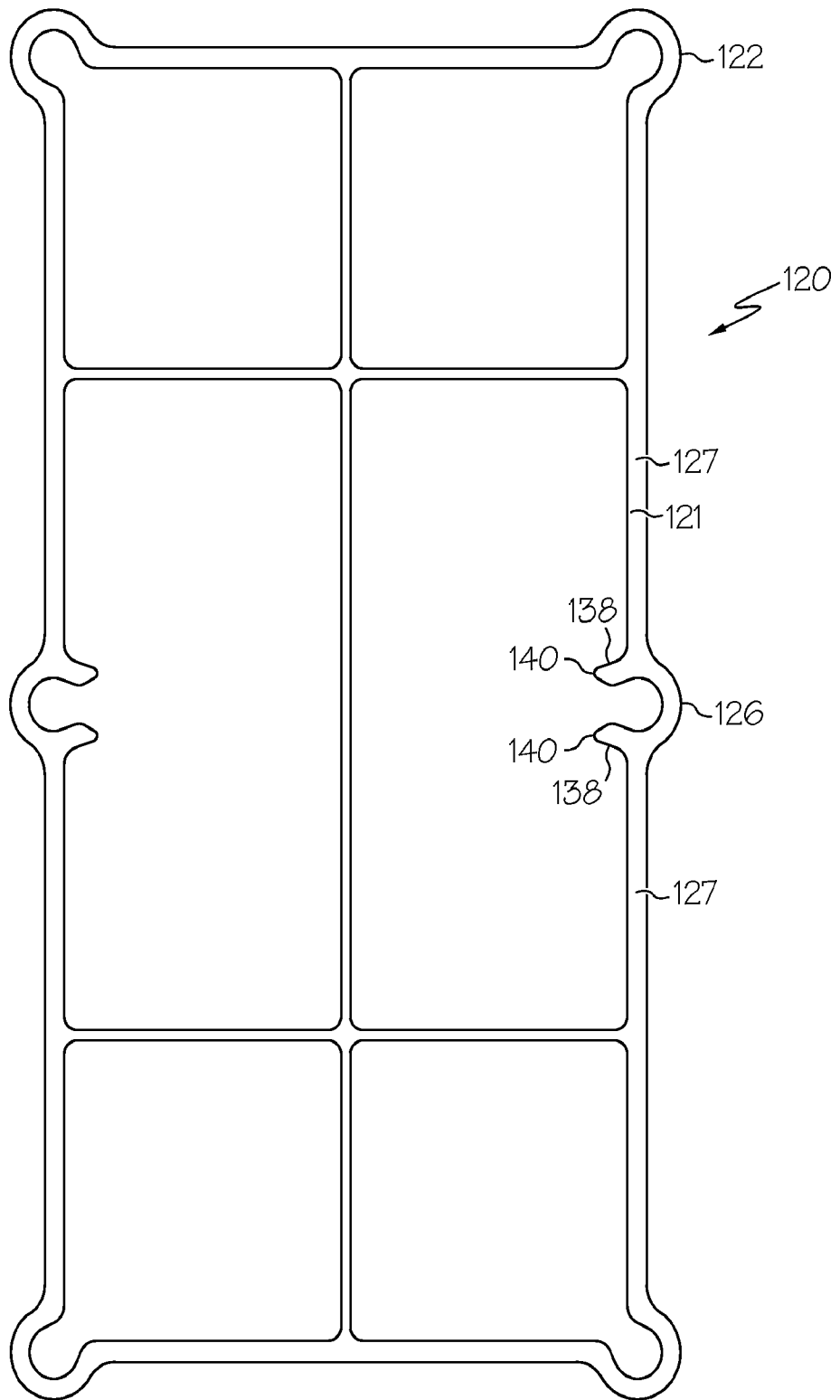

FIG. 4

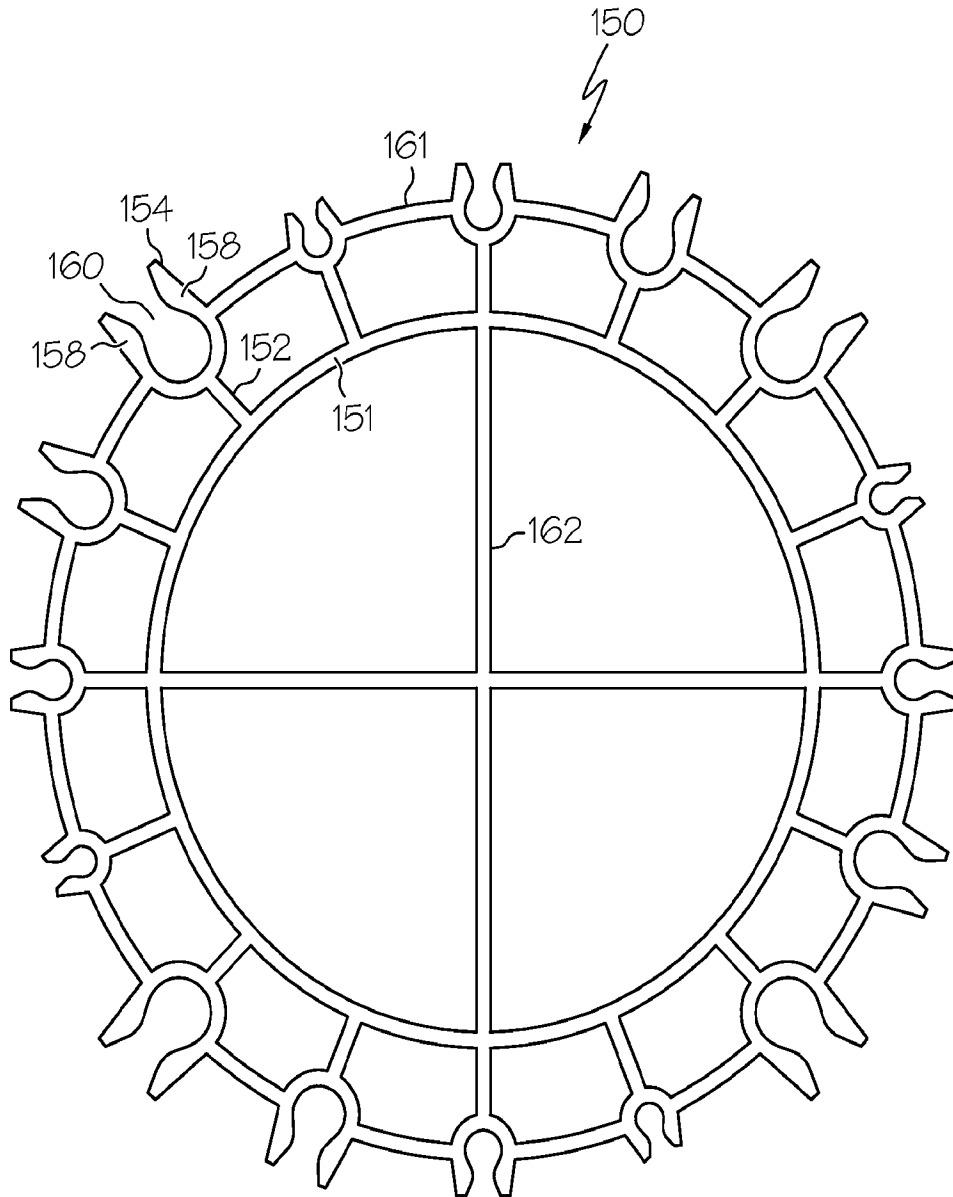

FIG. 5

7/9

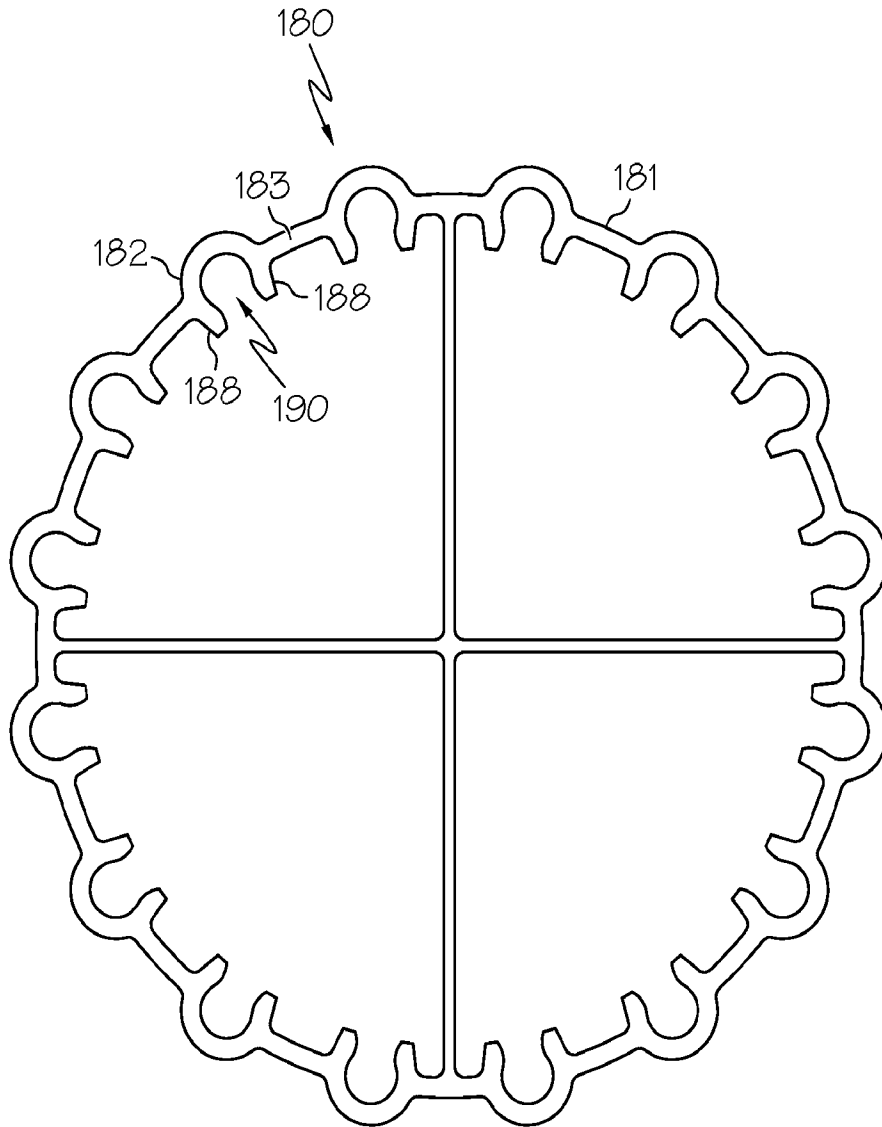

FIG. 6

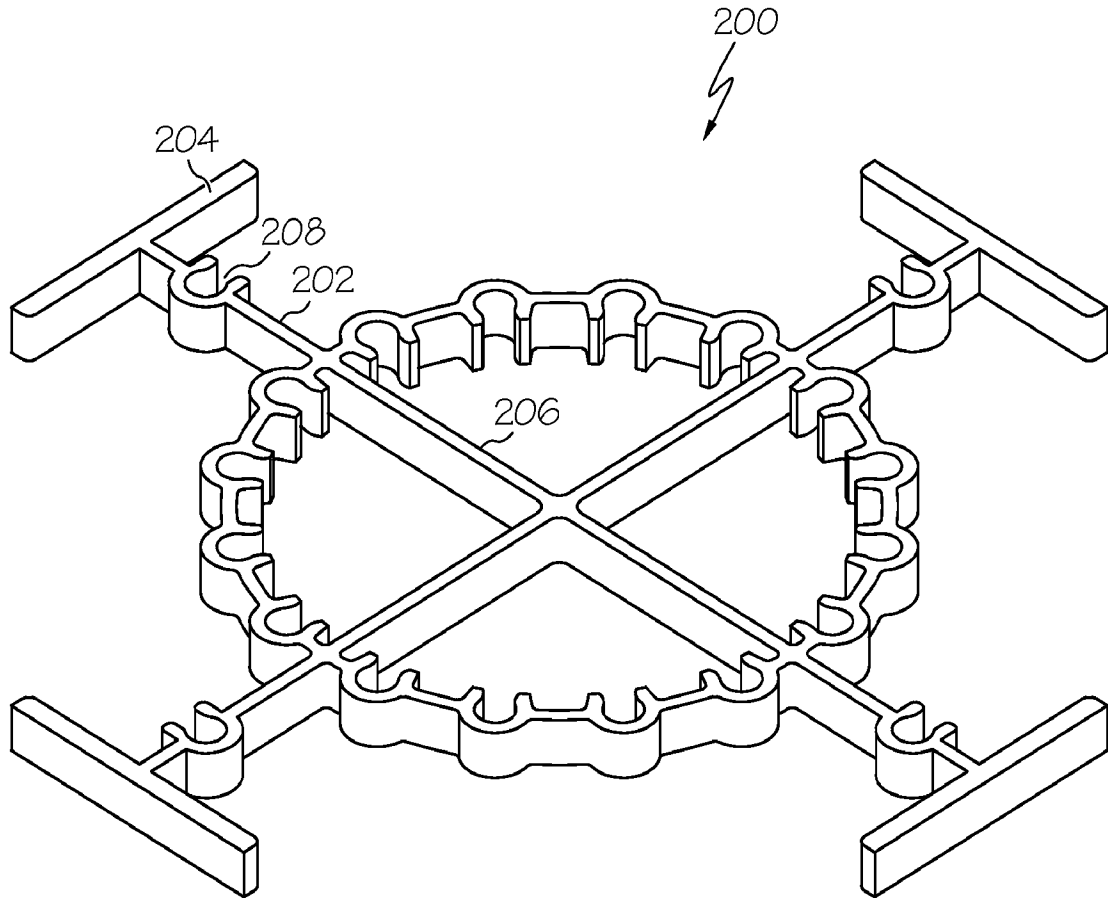

FIG. 7

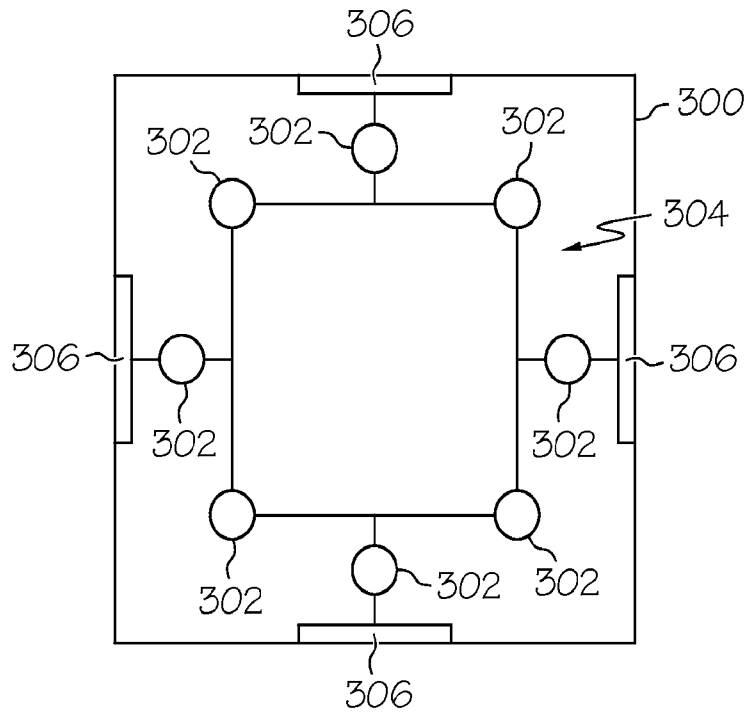

FIG. 8A

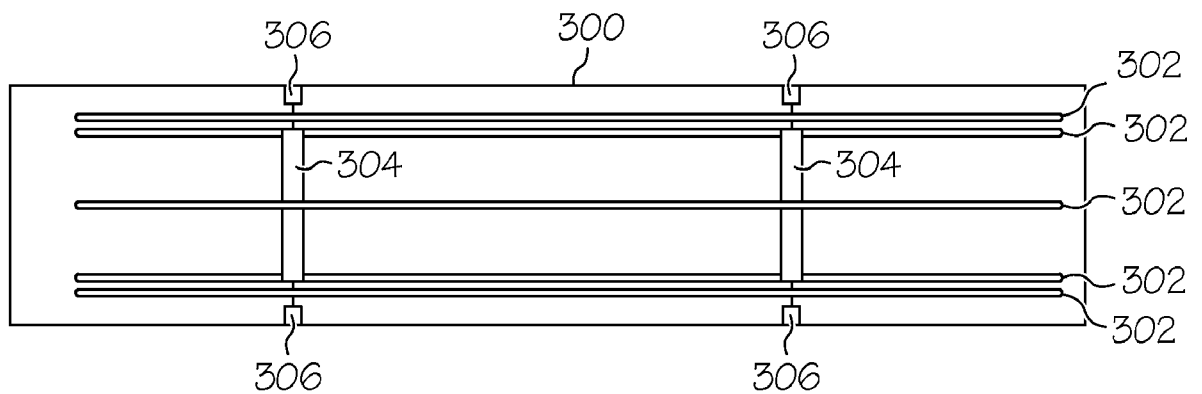

FIG. 8B