



US0D1069702S

(12) **United States Design Patent**
Hao et al.

(10) **Patent No.:** **US D1,069,702 S**

(45) **Date of Patent:** **** Apr. 8, 2025**

(54) **MULTIFUNCTIONAL DOCKING STATION FOR A CLEANING ROBOT**

FOREIGN PATENT DOCUMENTS

(71) Applicant: **Beijing Roborock Technology Co., Ltd.**, Beijing (CN)

CN 307042148 S 12/2021
CN 307338667 S 5/2022

(Continued)

(72) Inventors: **Pengfei Hao**, Beijing (CN); **Zechen Yu**, Beijing (CN); **Fanwei Meng**, Beijing (CN)

OTHER PUBLICATIONS

“Roborock Q Revo Robot Vacuum”. Found online Feb. 5, 2024 at amazon.com. Reference dated Feb. 15, 2023. Retrieved from https://www.amazon.com/dp/B0BVVSTJWS?th=1. (Year: 2023).*

(Continued)

(73) Assignee: **Beijing Roborock Technology Co., Ltd.**, Beijing (CN)

(**) Term: **15 Years**

Primary Examiner — Shawn T Gingrich

Assistant Examiner — Amanda Christensen

(21) Appl. No.: **35/517,823**

(74) *Attorney, Agent, or Firm* — Morgan, Lewis & Bockius LLP

(22) Filed: **Jun. 27, 2023**

(80) **Hague Agreement Data**

Int. Filing Date: **Jun. 27, 2023**

Int. Reg. No.: **DM/230149**

Int. Reg. Date: **Jun. 27, 2023**

Int. Reg. Pub. Date: **Jul. 14, 2023**

(57) **CLAIM**

The ornamental design for a multifunctional docking station for a cleaning robot, as shown and described.

(30) **Foreign Application Priority Data**

Jan. 4, 2023 (CN) 202330003640.8

(51) **LOC (15) Cl.** **13-02**

(52) **U.S. Cl.**
USPC **D13/108; D32/31**

(58) **Field of Classification Search**
USPC D13/103, 106, 107, 108, 109, 110, 118,
D13/119, 122, 199; D32/25, 30, 31;
D34/7

(Continued)

DESCRIPTION

- 1.1 is a front view of a first embodiment of a multifunctional docking station for a cleaning robot;
- 1.2 is a back view thereof;
- 1.3 is a left view thereof;
- 1.4 is a right view thereof;
- 1.5 is a top view thereof;
- 1.6 is a bottom view thereof;
- 1.7 is a front top perspective views thereof.
- 1.8 is a back top perspective views thereof.
- 1.9 is a back bottom perspective views thereof.
- 2.1 is a front view of a second embodiment of a multifunctional docking station for a cleaning robot;
- 2.2 is a back view thereof;
- 2.3 is a left view thereof;
- 2.4 is a right view thereof;
- 2.5 is a top view thereof;
- 2.6 is a bottom view thereof;
- 2.7 is a front top perspective views thereof; and
- 2.8 is a back top perspective views thereof.

(Continued)

(56) **References Cited**

U.S. PATENT DOCUMENTS

D961,177 S * 8/2022 Jang D32/31

D979,869 S * 2/2023 Johnson D32/31

(Continued)

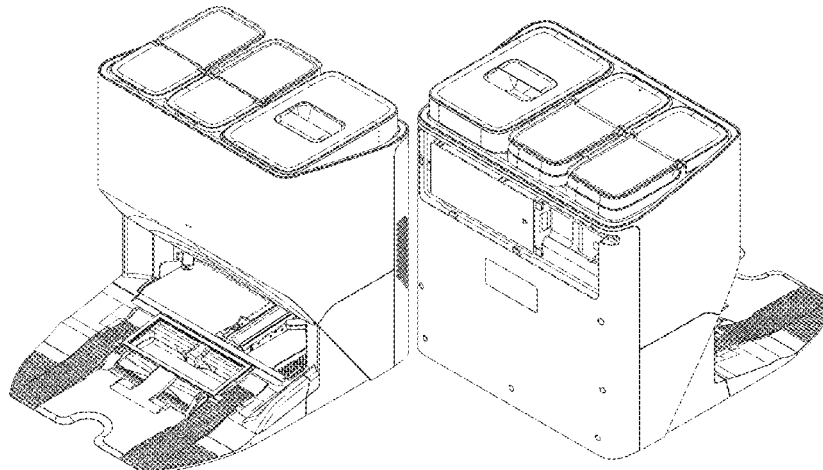

The broken lines in the reproductions depict portions of the multifunctional docking station for a cleaning robot that form no part of the claimed design.

1 Claim, 17 Drawing Sheets

2016/0183752	A1 *	6/2016	Morin	A47L 9/1625	15/340.1
2022/0287527	A1 *	9/2022	Hong	A47L 11/4091	
2022/0400925	A1 *	12/2022	Hoobler	A47L 9/149	
2023/0165425	A1 *	6/2023	Li	A47L 11/4088	15/319

FOREIGN PATENT DOCUMENTS

JP	D1708856	S	3/2022
JP	D1721481	S	8/2022

- (58) **Field of Classification Search**
 CPC H02J 7/0044; H02J 7/0045; A47L 9/2815;
 A47L 11/24
 See application file for complete search history.

OTHER PUBLICATIONS

“Roborock S8 series”. Found online Feb. 5, 2024 at androidheadlines.com. Reference dated Jan. 10, 2024. Retrieved from <https://www.androidheadlines.com/2024/01/hands-on-with-the-roborock-s8-series-q-revo-series-and-flexi-series.html>. (Year: 2024).*

“Roborock Pro Ultra Robot Vacuum”. Found online Feb. 5, 2024 at amazon.com. Reference dated Aug. 20, 2023. Retrieved from <https://www.amazon.com/dp/B0BVB5PTDK/?th=1>. (Year: 2023).*

Notice of Allowance issued in the corresponding Taiwanese Application No. 112303319, dated Dec. 18, 2023.

- (56) **References Cited**

U.S. PATENT DOCUMENTS

D980,162	S	*	3/2023	Hua	D32/31
D987,566	S	*	5/2023	Zhang	D13/108
D996,754	S	*	8/2023	Meng	D32/31
D997,479	S	*	8/2023	Meng	D32/31
D1,002,976	S	*	10/2023	Woessner	D32/31
D1,002,977	S	*	10/2023	Lu	D32/31
D1,006,730	S	*	12/2023	Li	D13/108

* cited by examiner

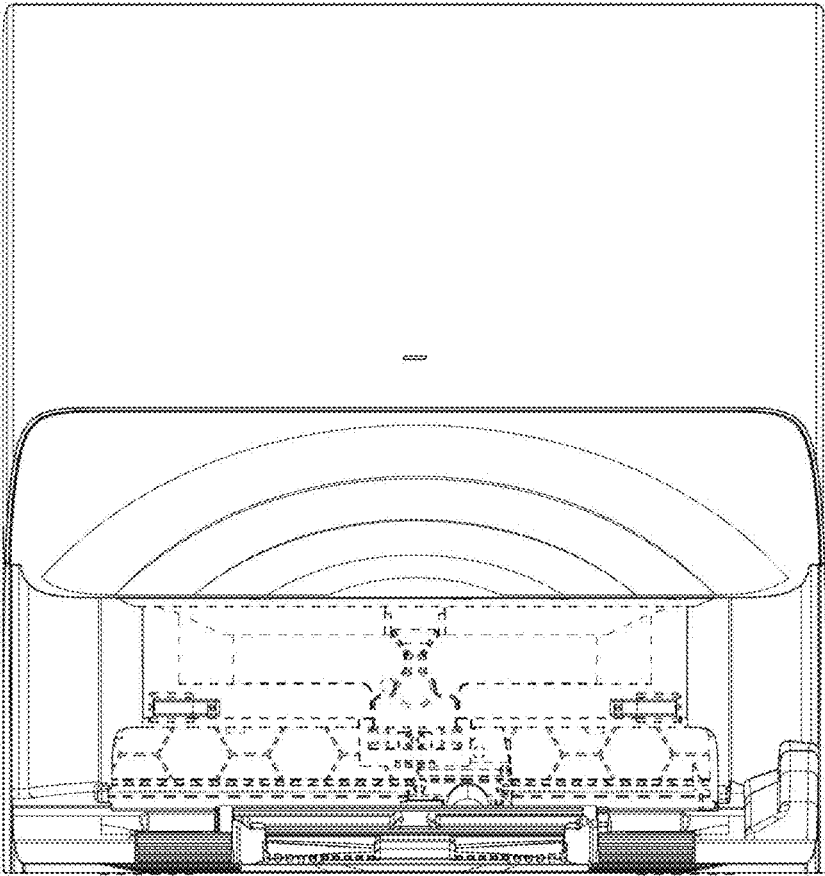

1.1

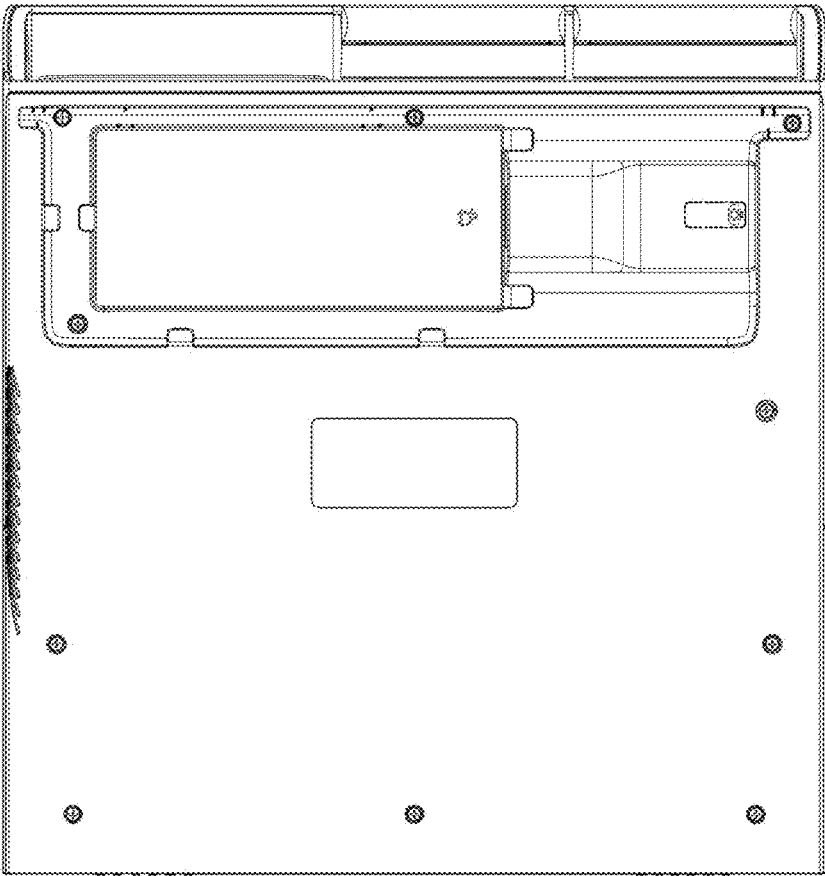

1.2

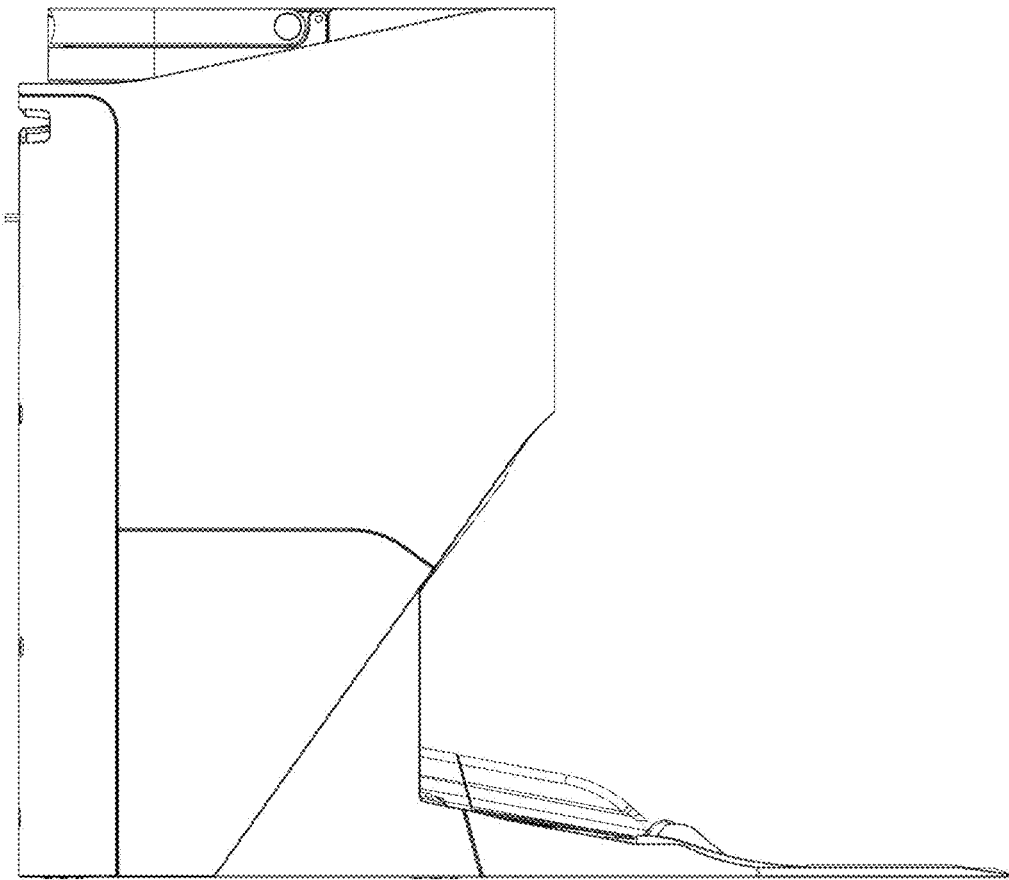

1.3

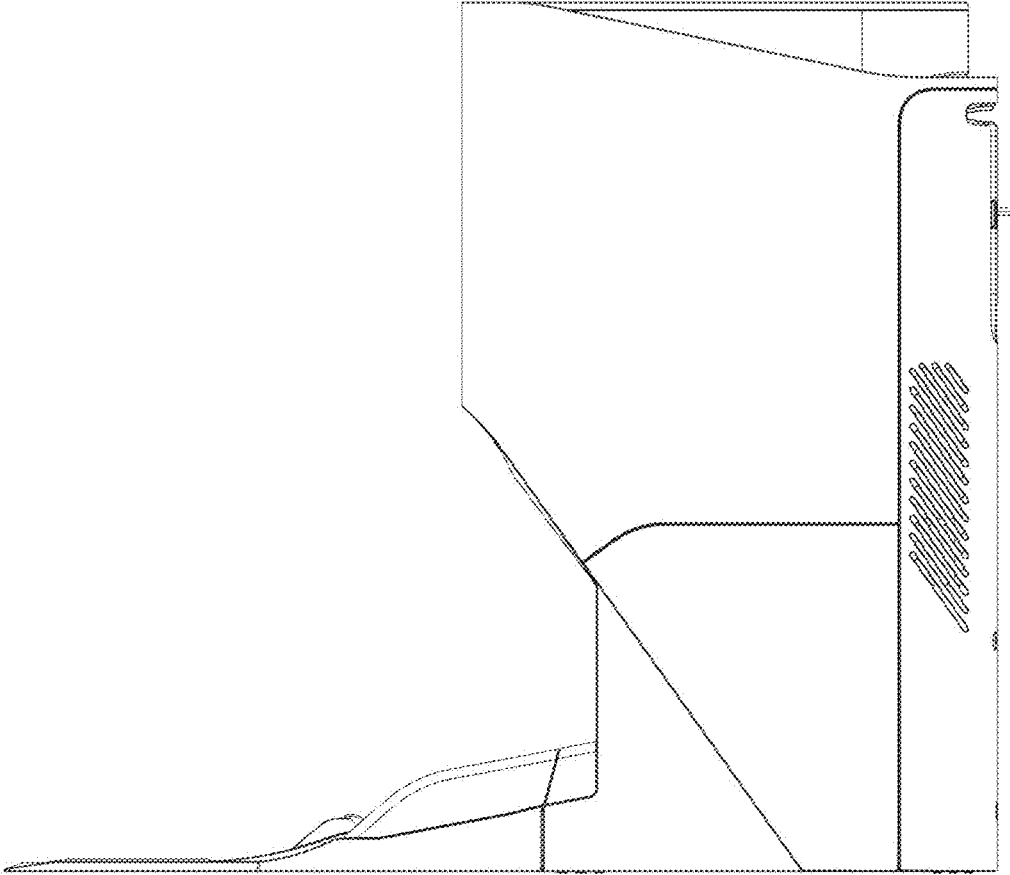

1.4

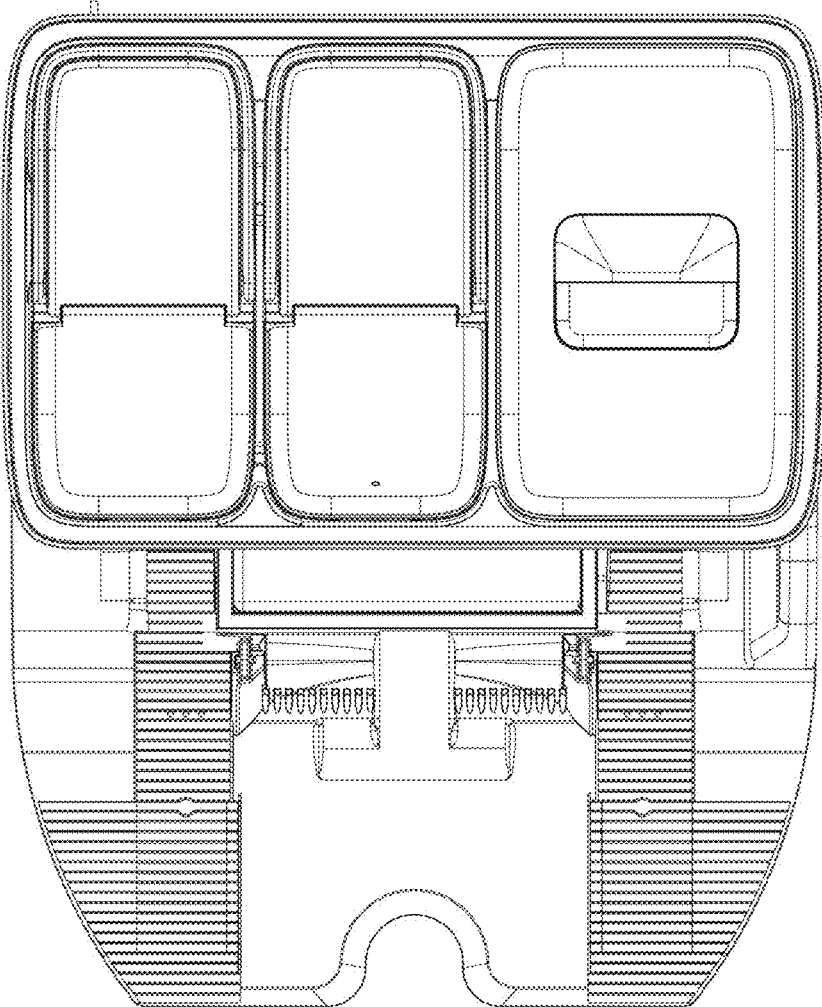

1.5

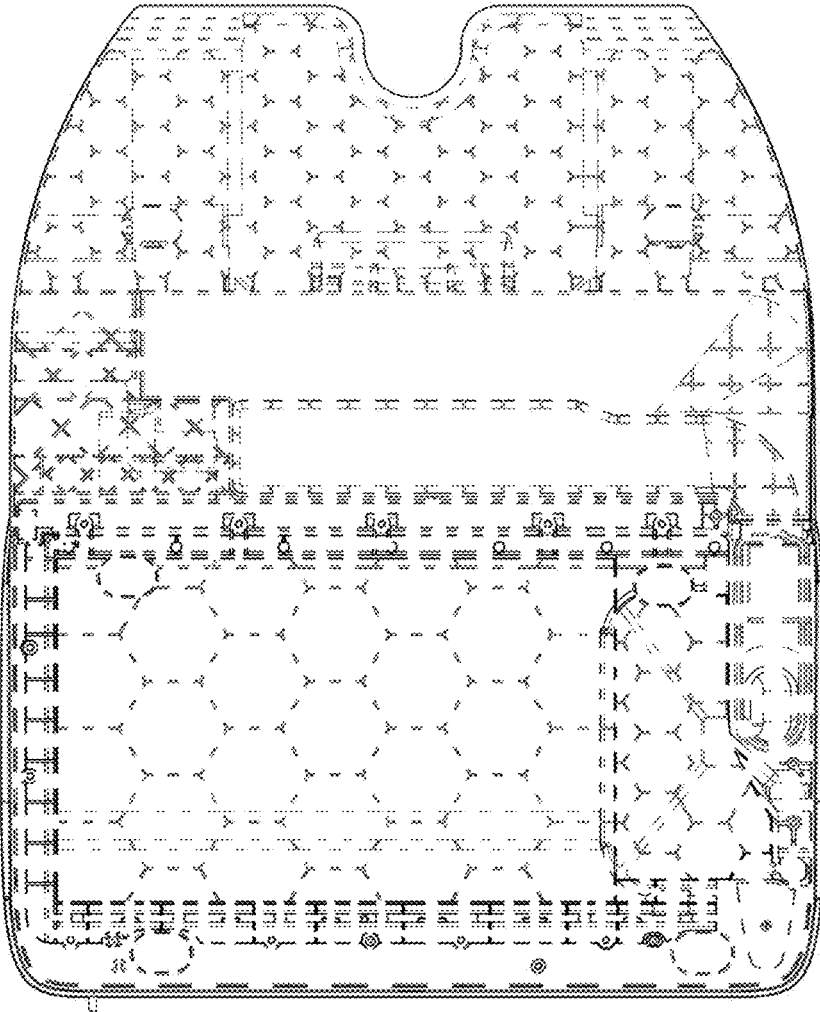

1.6

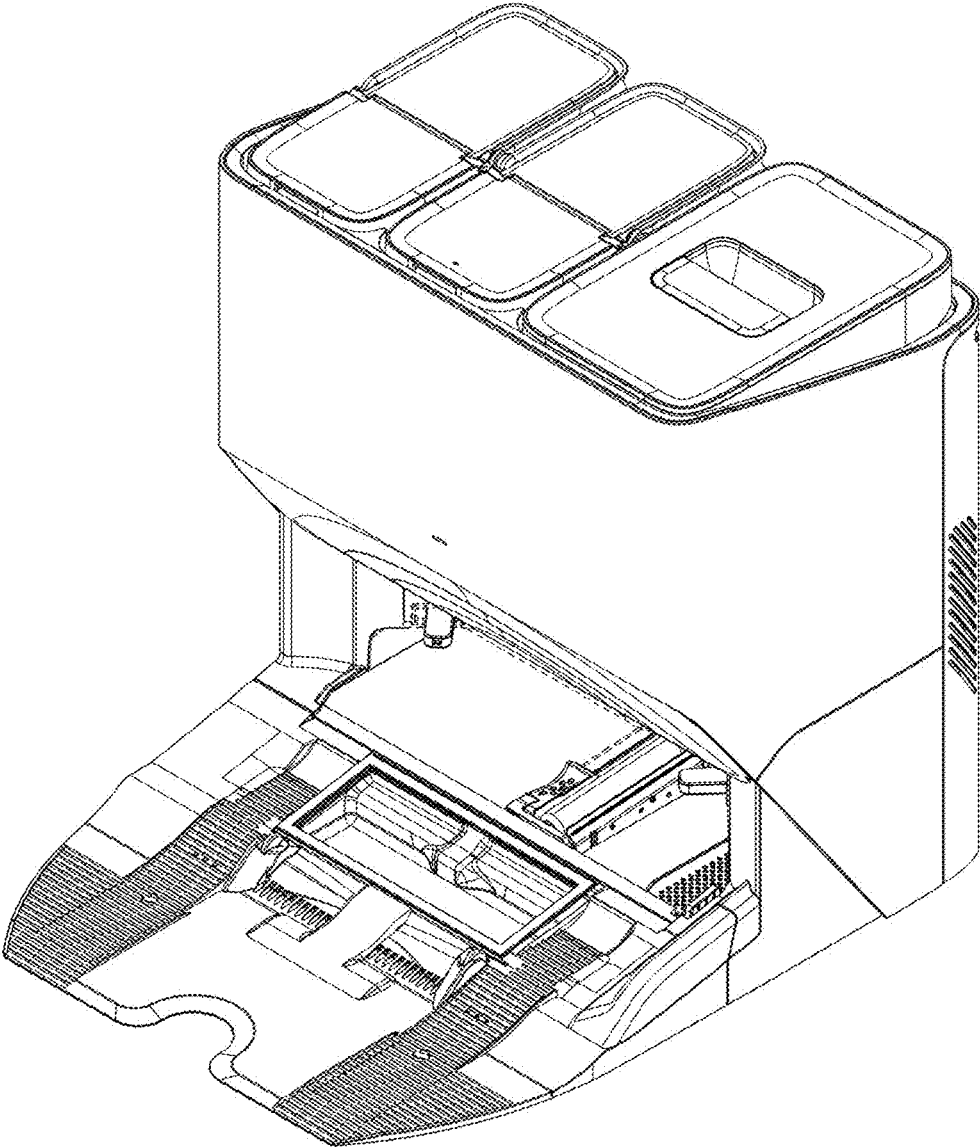

1.7

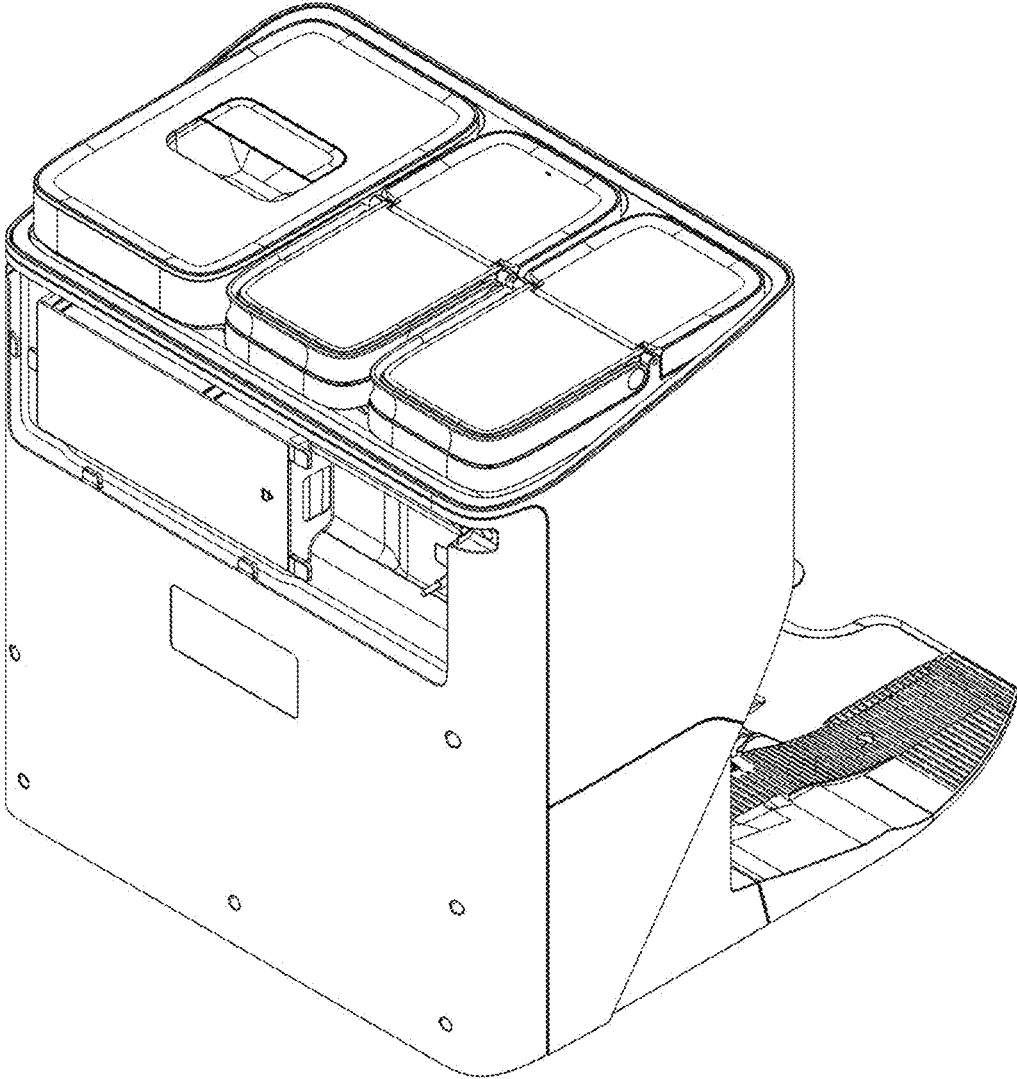

1.8

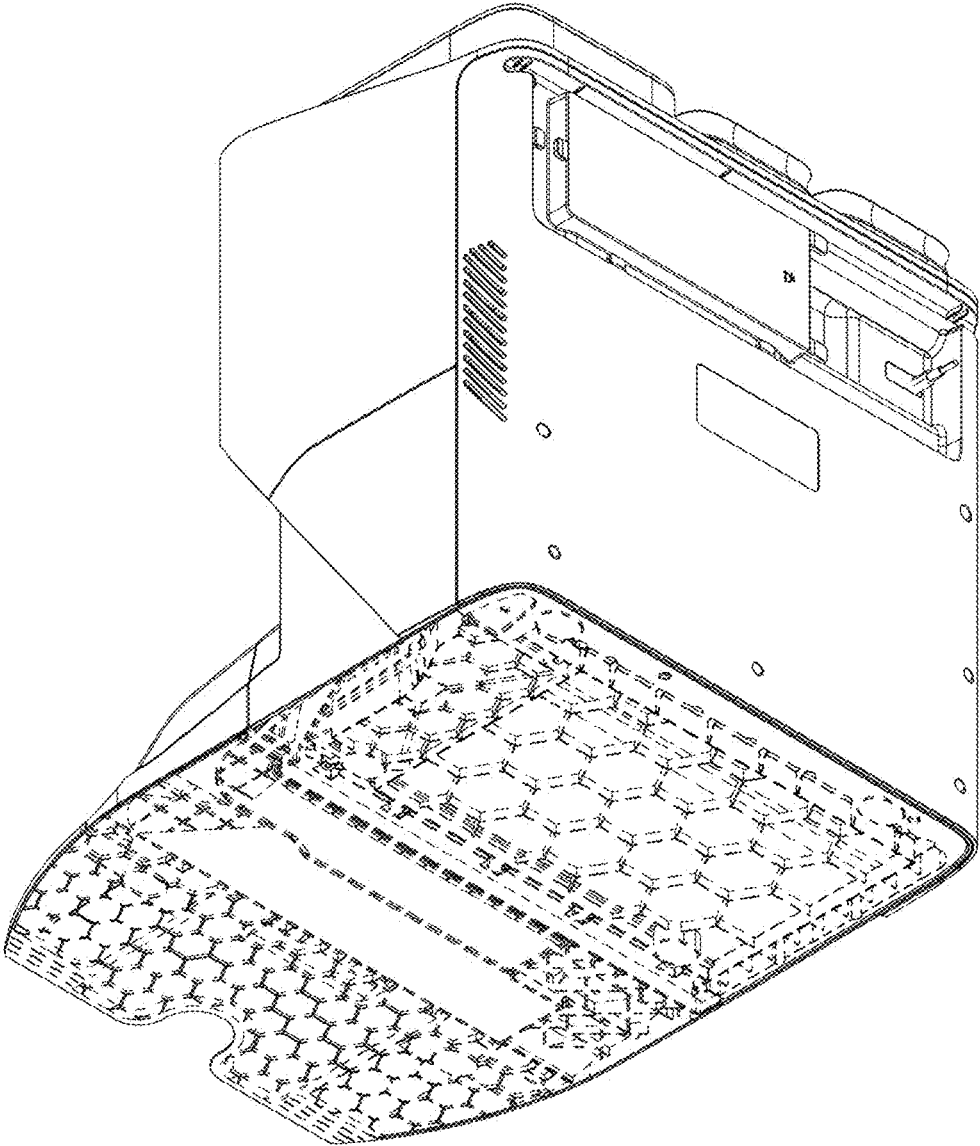

1.9

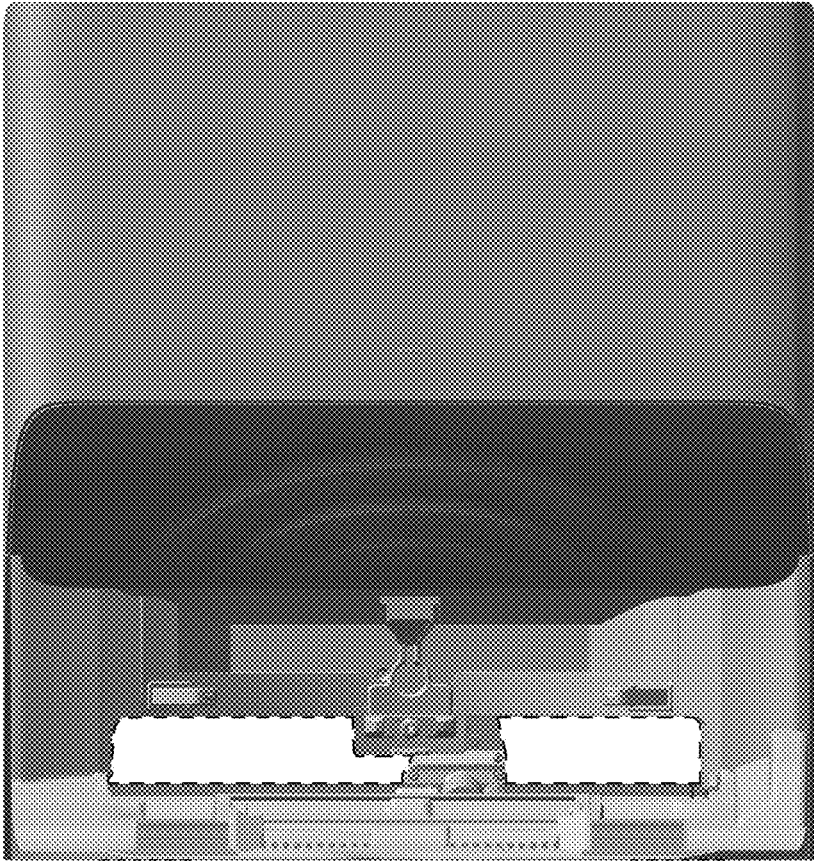

2.1

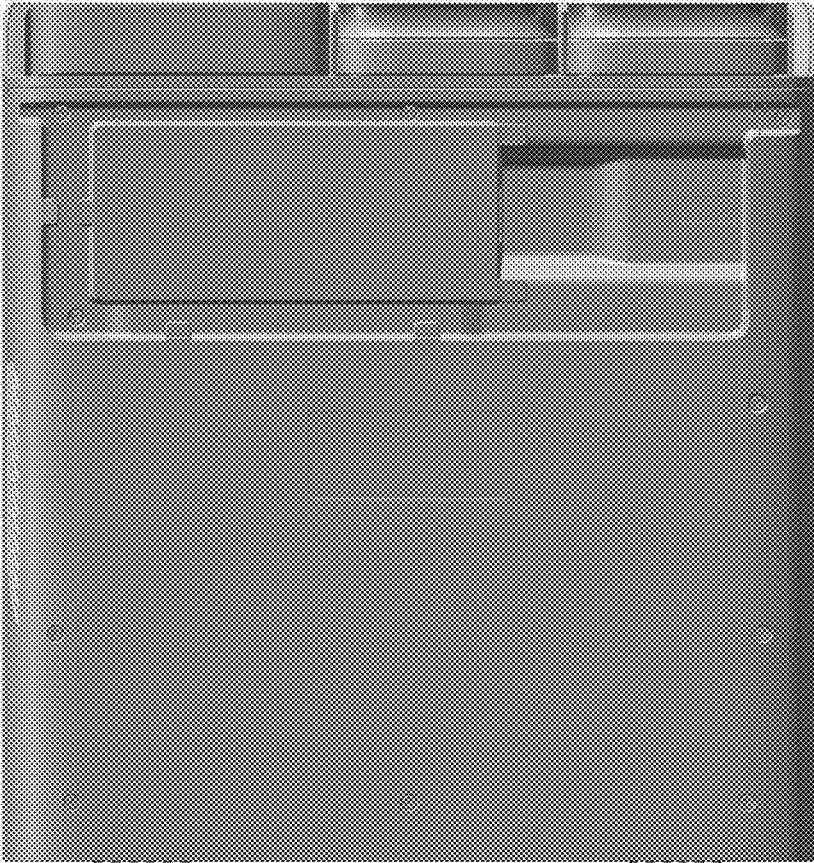

2.2

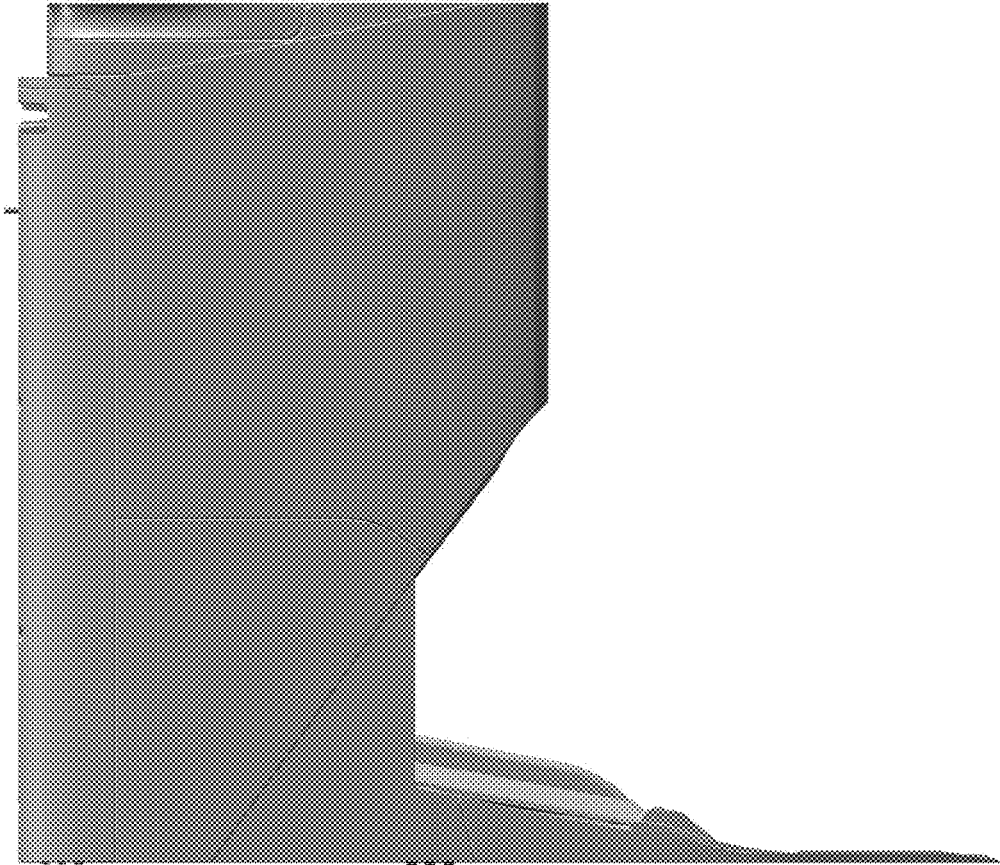

2.3

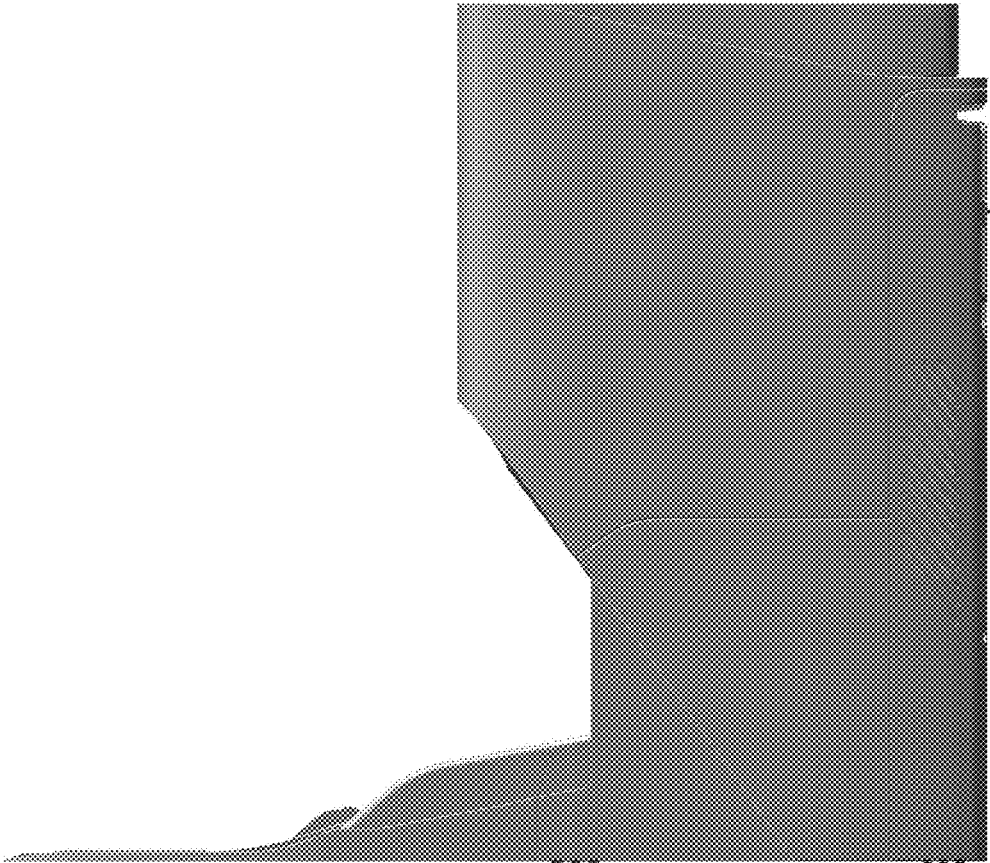

2.4

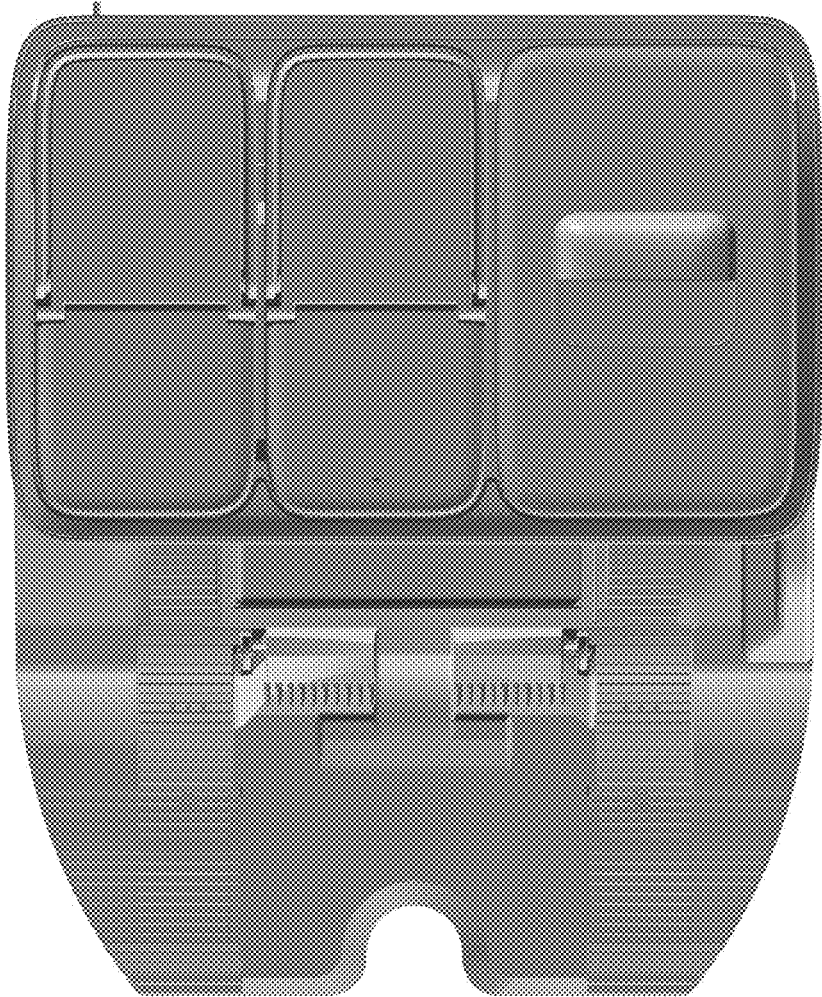

2.5

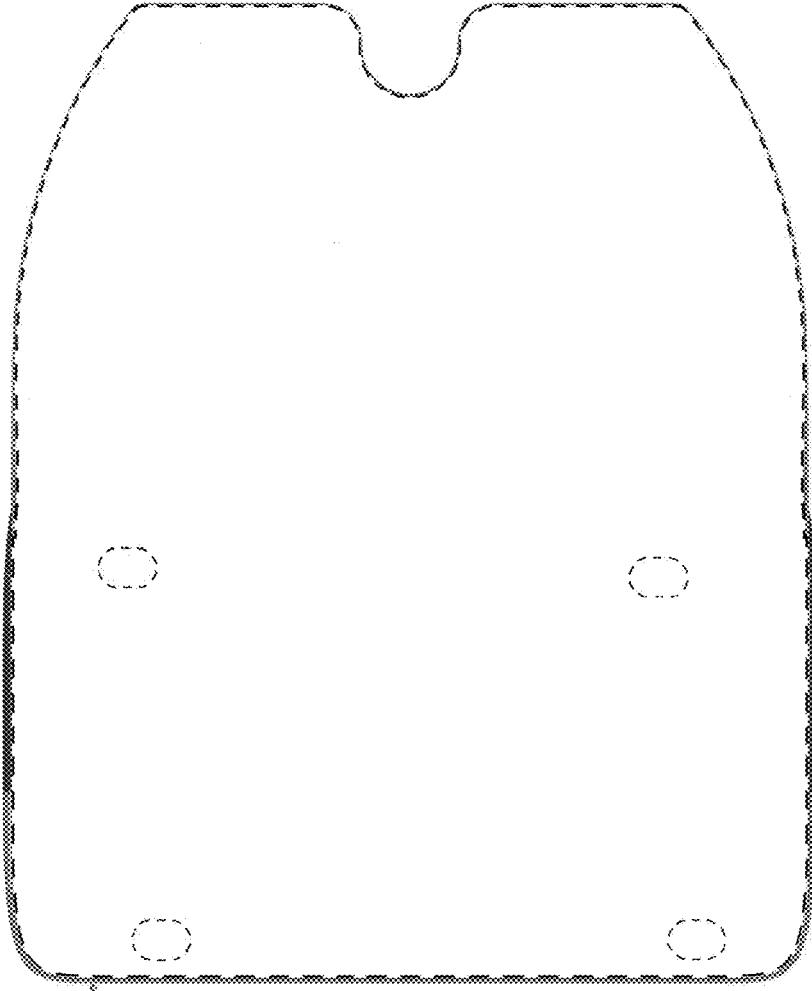

2.6

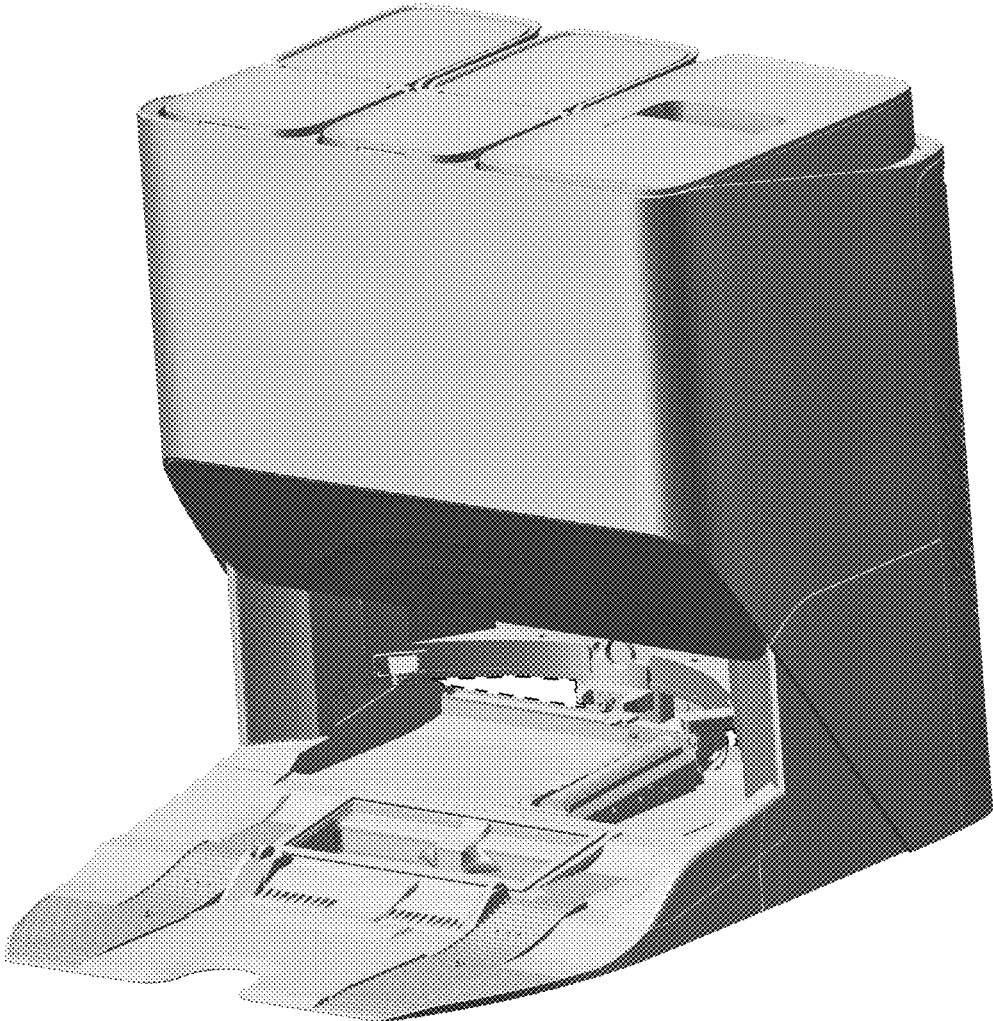

2.7

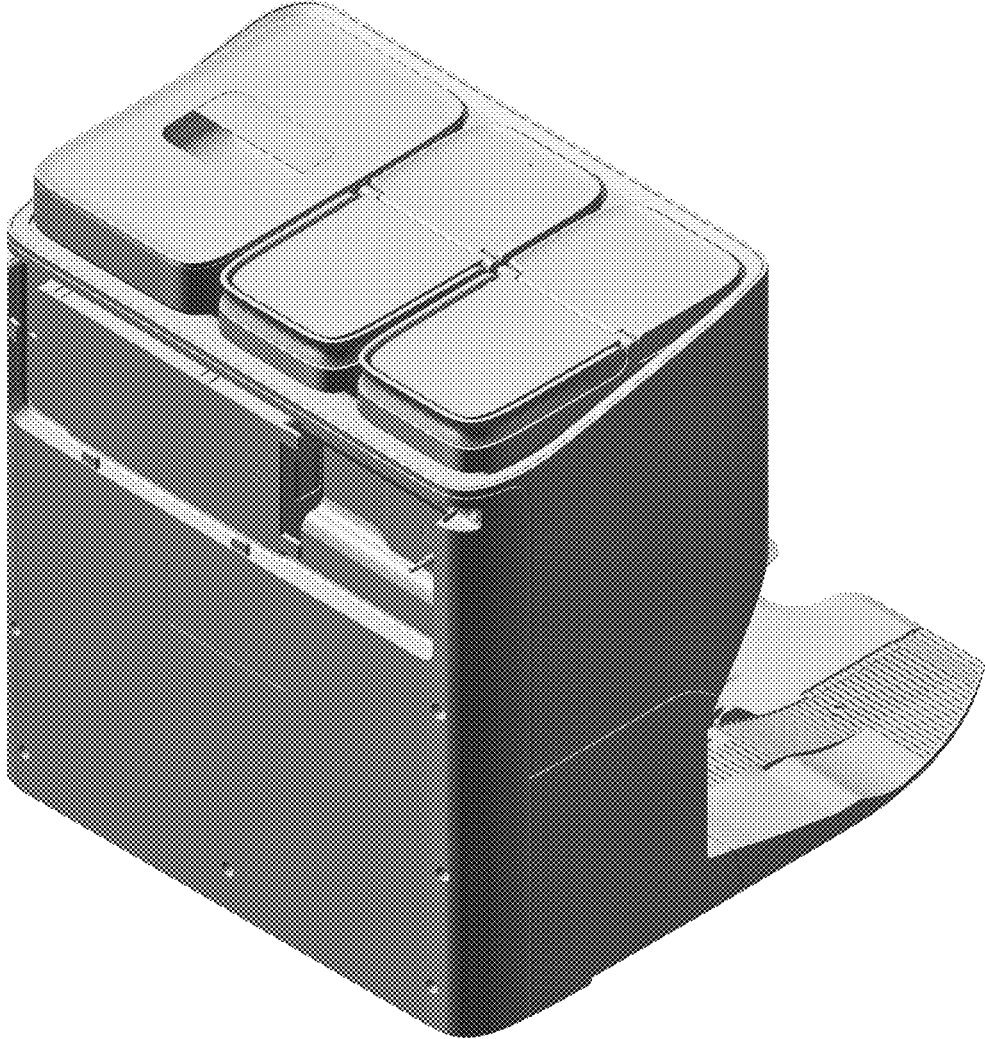

2.8