



(51) International Patent Classification:
A61M 16/06 (2006.01)

(74) Agent: BALDWINS INTELLECTUAL PROPERTY;
PO Box 852, Wellington, 6011 (NZ).

(21) International Application Number:
PCT/NZ2015/050019

(81) Designated States (unless otherwise indicated, for every kind of national protection available): AE, AG, AL, AM, AO, AT, AU, AZ, BA, BB, BG, BH, BN, BR, BW, BY, BZ, CA, CH, CL, CN, CO, CR, CU, CZ, DE, DK, DM, DO, DZ, EC, EE, EG, ES, FI, GB, GD, GE, GH, GM, GT, HN, HR, HU, ID, IL, IN, IR, IS, JP, KE, KG, KN, KP, KR, KZ, LA, LC, LK, LR, LS, LU, LY, MA, MD, ME, MG, MK, MN, MW, MX, MY, MZ, NA, NG, NI, NO, NZ, OM, PA, PE, PG, PH, PL, PT, QA, RO, RS, RU, RW, SA, SC, SD, SE, SG, SK, SL, SM, ST, SV, SY, TH, TJ, TM, TN, TR, TT, TZ, UA, UG, US, UZ, VC, VN, ZA, ZM, ZW.

(22) International Filing Date:
26 February 2015 (26.02.2015)

(25) Filing Language: English

(26) Publication Language: English

(30) Priority Data:
61/945,034 26 February 2014 (26.02.2014) US

(71) Applicant: FISHER & PAYKEL HEALTHCARE LIMITED [NZ/NZ]; 15 Maurice Paykel Place, East Tamaki, Auckland 2013 (NZ).

(84) Designated States (unless otherwise indicated, for every kind of regional protection available): ARIPO (BW, GH, GM, KE, LR, LS, MW, MZ, NA, RW, SD, SL, ST, SZ, TZ, UG, ZM, ZW), Eurasian (AM, AZ, BY, KG, KZ, RU, TJ, TM), European (AL, AT, BE, BG, CH, CY, CZ, DE, DK, EE, ES, FI, FR, GB, GR, HR, HU, IE, IS, IT, LT, LU,

(72) Inventor: LIM, Jae Yun; c/o Fisher & Paykel Healthcare Limited, 15 Maurice Paykel Place, East Tamaki, Auckland 2013 (NZ).

[Continued on next page]

(54) Title: RESPIRATORY MASK WITH NASOGASTRIC TUBE PATH

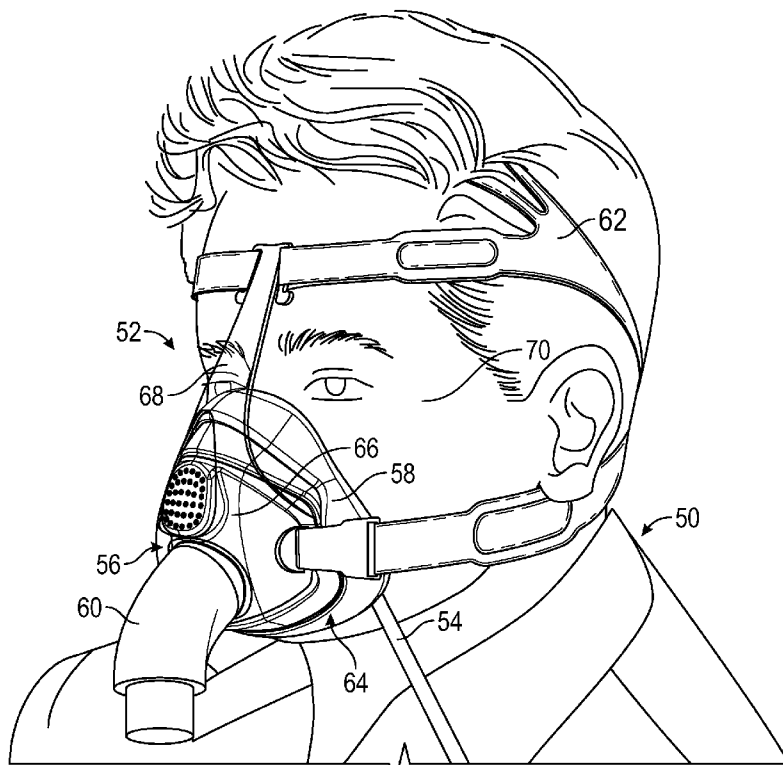

FIG. 1

(57) Abstract: A respiratory mask can be used to provide therapy to patients who also require a nasogastric (NG) tube. The mask seal can include a path that is designed to deform around an NG tube or other without lifting the mask away from a patient's face. The deforming path can help to minimize gaps that form between the patient's face and the mask seal as a result of the tube, thus reducing leaks and improving the efficacy of the treatment.

WO 2015/130179 A1

LV, MC, MK, MT, NL, NO, PL, PT, RO, RS, SE, SI, SK, **Published:**
SM, TR), OAPI (BF, BJ, CF, CG, CI, CM, GA, GN, GQ, — *with international search report (Art. 21(3))*
GW, KM, ML, MR, NE, SN, TD, TG).

RESPIRATORY MASK WITH NASOGASTRIC TUBE PATH

INCORPORATION BY REFERENCE TO ANY PRIORITY APPLICATIONS

[0001] Any and all applications for which a foreign or domestic priority claim is made are hereby incorporated by reference and made a part of the present disclosure.

BACKGROUND

Field

[0002] The present disclosure generally relates to respiratory masks, such as those intended for use in non-invasive ventilation (NIV). More particularly, the present disclosure relates to a seal or cushion for an NIV mask or other mask that enhances the sealing capabilities of the mask when used in combination with a tube, such as a nasogastric (NG) tube, a nasojejunal (NJ) tube and/or an oro-gastric (OG) tube, for example.

Description of Related Art

[0003] NIV masks commonly are used on patients who also require an NG, NJ and/or OG tube for feeding or delivery of medication. Traditionally, NIV masks are not designed for use in combination with an NG, NJ and/or OG tube and, as such, the efficacy of the NIV therapy can be compromised when such a combination is desired.

[0004] Traditional NIV masks have a silicone or thermoplastic elastomer (TPE) seal/cushion that conforms to a patient's face in order to create an air-tight seal. These cushions generally are flexible but not to an extent that allows the cushion to conform to very small features. In circumstances where an NG, NJ and/or OG tube is desired to be used in combination with an NIV mask, it is typical for the mask to be placed over the top of the tube(s). The tube(s) lift the cushion away from the patient's face, creating gaps around the tube that cause the seal to be broken and allow leaks to occur.

[0005] There are several techniques currently used to minimize gaps and to reduce leaks. These techniques include strapping the mask tighter onto the patient, using an adhesive pad to fill the gaps between the tube, cushion and patient's face, or passing the NG, NJ and/or OG tube through a port in the mask. Strapping the mask tighter can be uncomfortable for the patient and can lead to pressure-related skin damage. It also is possible

that the NG, NJ and/or OG tube may be deformed by the tight fit of the mask and this could lead to blockages within the tube. The use of an adhesive pad creates extra work for the clinician who is fitting the NG tube or other tube and mask because it is another component that has to be fitted and aligned. In addition, the pad may not be successful in blocking the gaps effectively if the tube is too large or small or if the tube and/or the pad are misaligned. Passing the NG, NJ and/or OG tube through a port in the mask eliminates any breaks in the seal caused by the tube but often requires the tube to be removed in order to remove the mask. Removing and replacing NG, NJ and/or OG tubes can be uncomfortable and can cause irritation to the patient.

SUMMARY

[0006] The systems, methods and devices described herein have innovative aspects, no single one of which is indispensable or solely responsible for their desirable attributes. Without limiting the scope of the claims, some of the advantageous features will now be summarized.

[0007] Certain features, aspects and advantages of the embodiments include a respiratory mask with a cushion that is designed to accommodate an NG, NJ and/or OG tube passing between the mask and a patient's face. The cushion has specific thin regions that are designed to conform to the geometry of an NG, NJ and/or OG tube, which regions can help to reduce or minimize leak-causing gaps that might be otherwise created between the cushion and the patient's face.

[0008] In some configurations, a cushion for a respiratory mask includes a face contacting portion and at least one thin region at least partially within the face contacting portion. The thin region is adapted to accommodate the placement of a tube between the face contacting portion and a face of a user.

[0009] In some configurations, in use, the at least one thin region is adapted to conform to a shape of the tube while substantially maintaining an adequate seal with the face of the user.

[0010] In some configurations, the at least one thin region is located on a lateral side of the face contacting portion.

[0011] In some configurations, the at least one thin region comprises a thin region on each lateral side of the face contacting portion.

[0012] In some configurations, the thin region on one lateral side is a relatively larger thin region and the thin region on the other side is a relatively smaller thin region.

[0013] In some configurations, the at least one thin region comprises two or more thin regions on one lateral side of the face contacting portion. In some configurations, a first thin region and a second thin region of the two or more thin regions are spaced apart from one another. In some configurations, the first thin region and the second thin region are spaced apart along a perimeter of the face contacting portion. In some configurations, the two or more thin regions comprise at least one relatively larger thin region and at least one relatively smaller thin region.

[0014] In some configurations, the at least one thin region extends in a direction from an inner edge of the face contacting portion toward an outer edge of the face contacting portion.

[0015] In some configurations, the at least one thin region extends downwardly relative to a horizontal axis from an inner end portion to an outer end portion. In some configurations, the at least one thin region extends downwardly at an angle of between about 5 degrees and about 45 degrees.

[0016] In some configurations, the cushion includes a smooth transition in thickness between the at least one thin region and an adjacent portion of the face contacting portion. In some configurations, the transition is substantially linear.

[0017] In some configurations, a thickness of the at least one thin region is between about 5 percent and about 80 percent of a thickness of an adjacent portion of the face contacting portion. In some configurations, the thickness of the at least one thin region is between about 10 percent and about 30 percent of the thickness of the adjacent portion of the face contacting portion.

[0018] In some configurations, end portions of the at least one thin region are rounded.

[0019] In some configurations, the inner end portion of the at least one thin region is spaced outwardly from the inner edge of the face contacting portion.

[0020] In some configurations, the outer end portion of the at least one thin region is spaced inwardly from the outer edge of the face contacting portion.

[0021] In some configurations, the tube is a feeding tube.

[0022] In some configurations, the cushion comprises a visual alignment indicator that indicates a proper location of the tube.

[0023] In some configurations, a patient interface includes a cushion comprising a face contacting portion and at least one thin region at least partially within the face contacting portion. The thin region is adapted to accommodate the placement of a tube between the face contacting portion and a face of a user.

[0024] In some configurations, the cushion is adapted to create a seal around the user's nose and/or mouth.

[0025] In some configurations, the cushion is configured such that an upper portion of the cushion can be deflected forward relative to a lower portion of the cushion.

[0026] In some configurations, a headgear retains the patient interface on the head of a user. In some configurations, a frame portion interfaces with the headgear and the cushion interfaces with the frame portion.

[0027] In some configurations, the cushion comprises a relatively soft portion defining the face contacting portion and a relatively rigid portion facing away from the relatively soft portion.

[0028] In some configurations, the at least one thin region is located on a lateral side of the face contacting portion.

[0029] In some configurations, the at least one thin region comprises a thin region on each lateral side of the face contacting portion.

[0030] In some configurations, the at least one thin region comprises two or more thin regions on one lateral side of the face contacting portion.

[0031] In some configurations, the at least one thin region extends downwardly relative to a horizontal axis from an inner end portion to an outer portion.

[0032] In some configurations, the cushion includes a smooth transition in thickness between the at least one thin region and an adjacent portion of the face contacting portion.

[0033] In some configurations, a thickness of the at least one thin region is between about 5 percent and about 80 percent of a thickness of an adjacent portion of the face contacting portion. In some configurations, the thickness of the at least one thin region is between about 10 percent and about 30 percent of the thickness of the adjacent portion of the face contacting portion.

[0034] In some configurations, the patient interface includes a visual alignment indicator that indicates a proper location of the tube.

BRIEF DESCRIPTION OF THE DRAWINGS

[0035] Throughout the drawings, reference numbers can be reused to indicate general correspondence between reference elements. The drawings are provided to illustrate example embodiments described herein and are not intended to limit the scope of the disclosure.

[0036] Figure 1 shows a view of a patient wearing a respiratory mask (e.g., an NIV mask) arranged and configured in accordance with certain features, aspects and advantages of the present disclosure in combination with a tube (e.g., an NG tube) that extends down and out of the lower left side of the mask as viewed by the patient.

[0037] Figure 2 is a profile view of a seal or cushion of the mask of Figure 1 adapting or conforming to an NG tube in comparison to a regular mask shown in dashed line.

[0038] Figure 3 is a profile view of the cushion of the mask of Figure 1 with no NG tube present.

[0039] Figure 4 is a perspective view of a portion of the mask of Figure 1 illustrating a rounded profile of a thin region of the cushion.

[0040] Figure 5 is a rear view of a portion the mask of Figure 1 illustrating an angled orientation of the thin region of the cushion.

[0041] Figure 6 is a rear view of a portion of the mask of Figure 1 sectioned through a portion of the cushion containing the thin region.

[0042] Figure 7 is an enlarged view of the sectioned portion of the cushion containing the thin region of Figure 6.

[0043] Figure 8 is a sectioned view of the portion of the cushion containing the thin region taken along line 8-8 of Figure 6.

[0044] Figure 9 is an outline of a shape of a thin region in a flattened condition.

[0045] Figure 10 is a rear view of a mask that shows a pair of thin regions on each side of the cushion, wherein the thin regions of the same side are differently sized and the thin regions are symmetrical between the sides.

[0046] Figures 11A and 11B are perspective views of portions of two different masks having different types of visual alignment indicators to facilitate positioning of the tube relative to the cushion.

DETAILED DESCRIPTION

[0047] In circumstances where NG, NJ and/or OG tubes are used in combination with NIV masks, undesirably high leak rates are a common occurrence. Having high leak rates can compromise the quality of therapy that a patient receives and the methods currently used to remedy the leaks can result in undesirable side-effects. Certain features, aspects and advantages of the disclosed embodiments seek to provide a useful alternative to currently known approaches of addressing and reducing these leaks.

[0048] The following description of certain features, aspects and advantages of certain embodiments refers to respiratory masks designed and configured to be used, or adapted for use, in combination with an NG tube; however, it is to be understood that the mask also can be used in combination with an NJ tube, both an NG tube and an NJ tube, which is more common, or any combination of an NJ tube, NG tube or OG tube. The respiratory masks can also be used, or adapted for use, with other types of tubes that are desired to pass between the mask cushion or seal and the patient's skin. Therefore, references to NG tubes herein can also refer to NJ tubes, OG tube, other tubes (e.g., fluid draining tubes) or any combination of NG tubes, NJ tubes, OG tube and other tubes.

[0049] The illustrated respiratory masks are NIV masks; however, the features, aspects and advantages described herein can be applied to other types of masks, as well. Certain features, aspects and advantages of the present masks are described in relation to providing therapy to adults; however, it also is possible to apply certain features, aspects and

advantages of the present disclosure to respiratory masks for any age group, including but not limited to neonatal, infant and pediatric patients.

[0050] Figure 1 illustrates a user or patient 50 wearing a respiratory (e.g., NIV) mask 52 in combination with an NG tube 54. The illustrated mask 52 includes a mask body or interface 56, which includes a cushion or seal 58 that contacts the user's face and surrounds the user's nose and/or mouth. The interface 56 also includes or is connected to a conduit connector 60 that allows the interface 56 to be connected to one or more gases conduits (not shown). In the illustrated arrangement, the conduit connector 60 is in the form of an elbow. A headgear 62 is coupled to the interface 56 and retains the interface 56 in position on the user's face.

[0051] The interface 56, conduit connector 60 and headgear 62 can take on many different forms. For example, the interface 56 can be a nasal interface, which covers only the user's nose, or a full face interface, which covers both the nose and mouth. Although a full face interface 56 is illustrated, the present disclosure can apply to other interface types in which a tube is desired to be passed between the interface cushion or seal and the user's face. The interface 56 can include or omit a forehead rest. In addition, the interface 56 (and, in some arrangements, the conduit connector 60) can be a one-piece structure or, as illustrated, can be an assembly of several components. The illustrated interface 56 includes a cushion module 64, which in some configurations includes a relatively rigid housing 66 and the relatively soft seal 58. The interface 56 also includes a frame 68, which can support the cushion module 64 and can provide connection or anchor locations for the headgear 62. The headgear 62 can be of any suitable arrangement, including single loop or multi loop arrangements.

[0052] It is typical for the NG tube 54 to be run from the nose towards the cheek and out the side of the mask 52. In a conventional mask, as illustrated by the dashed lines in Figure 2, this arrangement can result in the formation of gaps between the mask seal and a corresponding surface of the user's face 70. While flexible, the conventional cushion is not capable of conforming to the geometry of the tube 54 to a degree necessary to prevent undesirably high rates of gas leakage through the gaps between the cushion and the user's face 70. Instead, a relatively large length of the cushion lifts away from the user's face 70

and curves over the tube 54 leaving gaps on either side of the tube 54 where leaks can occur. In general, the larger the diameter of the NG tube 54, the larger the size of the gaps.

[0053] Certain features, aspects and advantages of the present embodiments seek to reduce the gaps that form between the mask cushion 58 and the surface of the user's face 70 when an NG tube 54 is used by providing a conformable or compliant region 72 in the mask cushion 58 that can conform to the NG tube 54 to a degree sufficient to create or maintain an adequate seal with the user's face 70. The conformable or compliant region 72 can be of any suitable arrangement to increase the conformability or compliance of a portion of the cushion 58 relative to adjacent or surrounding portions of the cushion 58. As described herein, the conformable or compliant region 72 can be or comprise a region of thinned material or a region of different material, among other possible arrangements.

[0054] Preferably, the conformable or compliant region 72 can allow the present cushion 58 to create or maintain a better seal with the user's face 70 than a conventional mask cushion. In some configurations, the present cushion 58 can accommodate an NG tube 54 with less gas leakage between the cushion 58 and the user's face 70 in comparison to a conventional cushion. In some configurations, the present cushion 58 can accommodate an NG tube 54 with no or substantially no gas leakage between the cushion 58 and the user's face 70 or gas leakage that is below a rate considered to be detrimental to the prescribed therapy. In some configurations, the leak rate with the present cushion 58 accommodating an NG tube 54 within the conformable or compliant region 72 is equal to or less than about 25 L/min at a normal pressure or flow rate range for the prescribed (e.g., NIV) therapy. In some configurations, the leak rate is less than about 20 L/min, less than about 15 L/min or less than about 10 L/min.

[0055] Figure 2 illustrates a profile view of an NG tube 54 passing between the cushion 58 and the user's face 70. The conformable or compliant region 72 creates a tube path that is more compliant and flexible than the surrounding or adjacent portions of the cushion 58. In some configurations, the conformable or compliant region 72 is more compliant and flexible than any other portion of the cushion 58. Figure 2 illustrates how the conformable or compliant region 72 stretches and deforms around the tube 54, which results in much smaller gaps at the side of the tube 54 than a cushion not having the specially

configured tube paths. The size of the gaps will be largely dependent on the tube size that is being used. In Figure 2, it is evident that the mask cushion 58 does not lift away from the face 70 to accommodate the NG tube 54 to the same degree as a traditional mask cushion that does not include tube paths.

[0056] The NG tube 54 has a cross-sectional dimension or diameter 74 extending in a direction away from the user's face 70. Preferably, the conformable or compliant region 72 allows the cushion 58 to contact or conform to at least a substantial portion of the NG tube 54 that is not in contact with the user's face 70. In some configurations, the conformable or compliant region 72 allows the cushion 58 to remain in contact with or conform to at least the outer one-third 76 of the surface of the NG tube 54 that is opposite the user's face 70. In some configurations, the conformable or compliant region 72 allows the cushion 58 to remain in contact with or conform to at least the outer one-half 78 of the surface of the NG tube 54. In some configurations, the conformable or compliant region 72 allows the cushion 58 to remain in contact with or conform to at least the outer two-thirds 80 of the surface of the NG tube 54. In some configurations, the conformable or compliant region 72 allows the cushion 58 to remain in contact with or conform to a substantial entirety of the surface of the NG tube 54 that is not in contact with the user's face 70.

[0057] Figure 3 illustrates a profile view of the mask cushion 58 of Figure 2 being used without an NG tube 54. Figure 3 illustrates that the conformable or compliant region 72 sits largely against and contacts the user's skin 70 when there is no NG tube 54 present. The external surface of the conformable or compliant region 72 can be shaped such that the conformable or compliant region 72 or tube path substantially follows the same contours as the rest of the mask cushion 58. Such a configuration helps the conformable or compliant region 72 to seal with the patient's face 70, which will create preferably no more than a negligible leak path in the absence of an NG tube 54. It is beneficial for the conformable or compliant region 72 to substantially follow the geometry of the rest of the cushion 58 because such a configuration will make the mask 52 more versatile and suitable for use on a wider range of users than otherwise possible. For example, the illustrated mask 52 can be used on any user or patient requiring NIV therapy, regardless of the need for use with tubes. Preferably, the patient-facing or contacting surface of the conformable or compliant region 72

and the patient-facing or contacting surface of the adjacent or surrounding portions of the cushion 58 define a continuous or uninterrupted surface. That is, preferably, there is no slit or other interruption in the patient-facing or contacting surface within or adjacent to the conformable or compliant region 72.

[0058] In some configurations, there may be a slight step in the external surface of the cushion 58. The slight step can be intentional or a result of the materials, configuration or manufacturing process used to create the conformable or compliant region 72. The step can be small enough that it will generate minimal leaks. The conformable or compliant region 72 may be flexible enough to inflate under the air pressure that is applied by the therapy such that the ballooning portion will fill any gaps that a step in the surface may otherwise cause.

[0059] As described above, the conformable or compliant region 72 can be of any suitable arrangement that provides for conformance to the type or size of the tube 54 or tubes intended for use with the mask 56. In some configurations, the conformable or compliant region 72 is substantially more conformable or compliant than surrounding or adjacent portions of the cushion 58. In some configurations, the increased conformability or compliance is at least partially the result of using a different material in the conformable or compliant region 72 relative to surrounding or adjacent portions of the cushion 58. For example, the increased conformability or compliance can be achieved through the localized use of a more elastic and flexible material. The different material can have a higher elasticity or different modulus of elasticity compared to the material of surrounding or adjacent regions of the cushion 58. Materials can include a different grade of silicone that is less hard or a more flexible TPE, for example but without limitation. In some configurations, the different material can also have a different thickness (e.g., less thickness) compared to the material of surrounding or adjacent regions of the cushion 58. The different material can be coupled to the material of surrounding or adjacent regions of the cushion 58 by any suitable process, which can include adhesive or chemical bonding or a co-molding or over-molding process, for example and without limitation, or any other appropriate method. In arrangements in which different material is utilized for the conformable or compliant region 72, the different material can extend beyond the conformable or compliant region 72. For example, such an

arrangement can provide a greater surface area overlap for bonding of the two materials to one another.

[0060] In some configurations, the conformable or compliant region 72 is or comprises a region of thinned material. In the illustrated arrangements of Figures 4-8, the conformable or compliant region 72 comprises a region of thinned material that is the same material as the material of surrounding or adjacent regions of the cushion 58. Thus, the thinned material region can be unitarily formed with surrounding or adjacent regions of the cushion 58. Hereinafter, the conformable or compliant region 72 may be referred to as a thin region or thinned region. However, in view of the alternative structures for the conformable or compliant region 72, such references to a thin region can also generally include other types of conformable or compliant regions, as well. The conformable or compliant region 72 can define a tube path or tube paths that accommodate the passage of the NG tube 54 or other tubes between the cushion 58 and the user's face 70 and, thus, can also be referred to herein as a tube path. In some configurations, the tube path or tube paths 72 are formed to be thinner than the adjacent portions of the cushion 58. In some configurations, the tube path or tube paths 72 are formed to be thinner than any other portion of the cushion 58.

[0061] Figures 4-8 illustrate the cushion module 64 separate from other portions of the mask 52. As described, the cushion module 64 comprises the housing 66 and the seal or cushion 58. In the illustrated arrangement, the conformable or compliant region 72 of the seal 58 is or comprises a thin region. Preferably, the thin region 72 is defined by the seal wall, which thin region 72 is more capable of conforming to the tube 54 relative to surrounding, adjacent or other portions of the cushion 58. The cushion 58 generally has a patient face contacting portion or side 90 and a portion or side 92 forward of the face contacting portion 90. The face contacting portion 90 is generally rearward-facing and contacts the user's face 70. The face contacting portion 90 can deform when placed into contact with the user's face 70 and an entirety of the rearwardly-facing portion may not contact the face of all users or under all circumstances or therapies. In the illustrated configuration, an upper portion of the cushion 58 can be deflected forwardly relative to a lower portion of the cushion 58 to better accommodate variations in the nasal geometry of potential users. Examples of such an arrangement are disclosed in Applicant's PCT

Publication No. WO2014/062070, the entirety of which is hereby incorporated by reference herein and made a part of the present disclosure. The cushion 58 can be made from one or more generally flexible materials, such as silicone or a TPE, for example but without limitation.

[0062] A location of the thin region 72 is illustrated by an outline on an exterior surface of the cushion 58 in Figures 4 and 5. However, preferably, the thin region 72 is defined by a recess 94 defined by an interior surface of the cushion 58, as illustrated in Figures 6-8. The geometry of the thin region 72 can be configured or adapted to conform to a size or shape of the tube(s) intended for use with the mask 52. In some configurations, the thin region 72 can be positioned at least partially or entirely within the face contacting portion 90 of the cushion 58. With reference to Figure 5, the thin region 72 extends generally in a direction from an inner edge 96 of the face contacting portion 90 towards an outer edge 98 of the face contacting portion 90. In some configurations, the thin region 72 can be spaced from one or both of the inner edge 96 and the outer edge 98. In some configurations, as illustrated in Figure 4, the thin region 72 can extend beyond the outer edge 98 of the face contacting portion 90 and into the forward portion 92 of the cushion 58.

[0063] In some configurations, the thin region 72 is angled relative to a horizontal axis 100 of the cushion 58 or cushion module 64. A vertical axis 102 can bisect the cushion 58 or cushion module 64 in a vertical direction and the horizontal axis 100 is perpendicular to the vertical axis 102 and extends in a lateral direction of the cushion 58 or cushion module 64. An axis 104 of the thin region 72 and the horizontal axis 100 can define an angle therebetween of between about 5 degrees and about 45 degrees, or more if desired. In one configuration, the angle between the axis 104 and the horizontal axis 100 is about 20 degrees. In the illustrated arrangement, an inner end 106 of the thin region 72 closer to the centerline or vertical axis 102 is higher than an outer end 108 of the thin region 72 that is further from the centerline or vertical axis 102. Such an arrangement accommodates the typical path of the NG tube 54 as illustrated in Figure 1. However, the thin region 72 can be provided in other orientations to suit other applications, as desired. For example, an oro-gastric (OG) tube may extend through the cushion 58 at about 0 degrees or generally along the horizontal

axis 100. Thus, the specific orientation of the thin region 72 can be selected as desired in view of the particular tube, tube orientation or other relevant factors.

[0064] The thin region 72 can have any suitable size or shape to configured or adapted to conform to a size or shape of the tube(s) intended for use with the mask 52. In the illustrated arrangement, the thin region 72 defines substantially linear side edges 110 and 112 extending between the inner end 106 and the outer end 108. The side edges 110 and 112 can be substantially parallel to one another. The axis 104 can be defined as a line parallel to an equidistant from the side edges 110, 112. In some configurations, one or both of the inner end 106 and the outer end 108 can have a rounded or substantially semi-circular profile, as shown in Figures 4 and 5. This geometry will result in the thicker side-wall structure of the cushion 58 butting up to the circumference of the NG tube 54, and the thin region 72 deforming between the thicker side-wall and the tube 54. The thin region 72 can be thin enough to deform and stretch over an NG tube 54 for which the mask 52 is intended or approved for use without significantly lifting the cushion 58 away from the patient's face 70. In some configurations, no lift or substantially no lift will occur. The rounded geometry of the ends 106, 108 of the conforming region 72 can minimize the likelihood of the NG tube 54 being deformed or constricted by the relatively thicker adjacent wall portion of the cushion 58.

[0065] Figures 6-8 show cross-sectional views of the thin conforming region 72 of the cushion 58. In the illustrated configuration, the internal surface of the cushion 58 may reduce or step down from a relatively thicker wall section to the relatively thinner and more conformable portion 72 to define the interior recess 94 while the external surface can remain substantially unchanged. In other words, the external surface is continuous and uninterrupted between the thin region 72 and the adjacent or surrounding portions of the cushion 58. However, in some configurations, the external surface could include a recess in addition to or in the alternative to the internal recess 94 and ballooning a result of internal gas pressure could be relied on to create a seal with the user's face 70 in the absence of a tube 54.

[0066] The recess 94 can define a length 114 in a direction along the axis 104 and a height 116 in a direction perpendicular to the axis 104. The length 114 can be selected to extend along a length of the face contacting portion 90 that is likely to be in contact with the

user's face 70 under typical or expected operating conditions. In some configurations, the length 114 is between about 15 mm and about 20 mm. The length 114 can vary with the size of the cushion 58 or can remain constant between different sized cushions 58. For example, the length 114 can vary from about 15.5 mm in a small cushion 58 to about 19 mm or 19.3 mm for a large cushion 58. The height 116 can be selected to accommodate the diameter or cross-sectional dimension of the tube(s) with which the mask 52 is designed or intended to be used. In some configurations, the height 116 is substantially equal to somewhat larger than the diameter of the maximum tube size with which the mask 52 is designed or intended to be used. In some configurations, the height 116 is between about 5 mm and about 15 mm, or between about 10 mm and 12 mm. The height 116 can vary with the size of the cushion 58, such as about 9 mm for an extra small cushion, about 10 mm for a small and medium cushion and about 11 mm for a large cushion. Alternatively, the height 116 can remain constant between cushion sizes.

[0067] The thin region 72 defines a wall thickness 118 that is less than a wall thickness 120 of portions of the cushion 58 adjacent to or surrounding the thin region 72. Preferably, the wall thickness 118 of the thin region 72 is less than the wall thickness 120. In some configurations, the wall thickness 118 is about 5 percent to about 80 percent or about 10 percent to about 30 percent of the wall thickness 120. In some configurations, the wall thickness 118 represents a reduction in thickness relative to the wall thickness 120 of between about 70 percent to about 95 percent, or about 80 percent to about 90 percent. For example, in some configurations, the wall thickness 120 can be about 1.49 or 1.5 mm and the wall thickness 118 can be between about 0.1 mm and about 0.5 mm, or between about 0.15 mm and about 0.3 mm. In some configurations, the wall thickness 118 is about 0.3 mm. The wall thickness 118 within the recess 94 is illustrated as substantially constant (not including the transition portions between the recess 94 and the surrounding or adjacent portions of the cushion 58). However, in other arrangements, the wall thickness 118 can vary within the recess 94.

[0068] The cushion 58 can define a depth 121 (Figure 8) in a forward-rearward direction from a rearward most point on the patient contacting portion 90 at a height of the thin region 72 and a location of the outer end 108 of the thin region 72. Having a sufficient

depth 121 can assist the cushion 58 to remain in contact with the user's face 70 with an NG tube 54 in place. However, preferably, the depth 121 is not too large, or the thin region 72 does not extend too far toward or into the forward portion 92 of the cushion 58 to avoid unnecessary weakening of the cushion 58. The depth 121 can be related to the size of tube 54 with which the mask 52 is designed, intended or approved for use. In some configurations, the depth 121 is between about 10 mm and about 20 mm, or between about 15 mm and about 18 mm. The depth 121 can vary with the size of the cushion 58, such as about 14 mm or 14.3 mm for an extra small cushion, about 15.7 mm or about 16 mm for a medium cushion and about 17.8 mm or 18 mm for a large cushion. Alternatively, the depth 121 can remain constant between cushion sizes.

[0069] In some configurations, the transition in thickness between the recess 94 and the adjacent or surrounding portions of the cushion 58 can be relatively abrupt. The abrupt transition can create a fold point that restricts deformation that may be caused by a tube to the relatively thinner region 72 of the cushion 58. The relatively thinner region 72 can deform, stretch and/or bunch up until a relatively thicker wall portion is encountered, which can limit any further deformation. In other configurations, the transition in thickness can be less abrupt, as illustrated by the dashed lines at the edges of the recess 94 in Figure 7. A smooth or less abrupt transition may be preferred for other reasons, such as manufacturability reasons, for example. Preferably, the transition is limited to a relatively small distance from the recess 94 or relatively small area surrounding the recess 94. For example, the transition can be substantially linear and/or can be an angle sufficient to allow the practical removal of a molded cushion 58 having the thin region 72 from a mold. In some configurations, the transition region preferably extends away from the thin region 72 a distance of no more than the width or length of the thin region 72 and, preferably, extends no more than a portion of the width or length of the thin region 72 (e.g., less than one-half, one-third or one-quarter of the width or length of the thin region 72).

[0070] Figure 9 illustrates one example of an outline of a recess or thin region 72 in a flattened condition. In practice, the thin region 72 is likely to be curved or three-dimensional in shape because many patent contacting surfaces of mask cushions are curved in lateral and/or vertical directions. In Figure 9, each end 106, 108 of the thin region 72 is

semi-circular in shape about a respective center 122. Thus, a distance 124 between the centers 122 plus the radius of each end 106, 108 equals the overall length 114 of the thin region 72. In the illustrated thin region 72, the side edges 110, 112 are parallel to one another and each end 106, 108 is of an equal radius. However, in other arrangements, the thin region 72 can have other suitable shapes.

[0071] In some configurations, such as that shown in Figure 10, the conforming thin regions or tube paths 72 can be provided in multiple locations. Figure 10 shows a rear view of the cushion 58 with two tube paths 72 spaced from one another along a perimeter of the cushion 58 and symmetrically located on each side of the mask 52. Having paths 72 on each side of the mask 52 allows for an NG tube 54 to be secured to either side of the patient's face 70. It is common practice for NG tubes 54 to be alternated between a patient's nostrils in order to reduce irritation and tissue damage within the nasal passage. Having symmetrical tube paths 72 on the mask 52 enables a clinician to change the side that the NG tube 54 is secured to and to continue to use the same mask 52. Such a configuration reduces wastage of equipment and may reduce work for the clinicians. Additionally, having tube paths 72 on both sides enables a cushion 58 to seal when both an NG tube 54 and an NJ tube are in simultaneous use.

[0072] Also shown in Figure 10 are two different tube path 72 sizes. Because NG tubes 54 come in a variety of sizes, it is beneficial for the tube paths 72 to be able to conform to any size or at least commonly used sizes. It may be desired to have more than one path size in a mask 52 in order to cover a wider range of tube diameters with at least acceptable leak-rate performance. If a tube is too small for the tube path 72, the relatively thicker wall section of the cushion 58 may not be able to adequately restrict the deformation of the thin region 72 and gaps may form, which gaps can result in leaks. The size of the tube path 72 can be defined to suit a certain range of tube diameters. It is desirable for the round/circular profile of the tube path 72 to generally correlate to or match the tube diameter, as discussed above. By closely matching or generally correlating the tube path 72 to the tube 54, the relatively thicker wall section can force the thin region 72 to conform around the tube 54.

[0073] It is preferable not to have too many tube paths 72 or tube paths 72 that are too large because they can reduce the structural integrity of the cushion 58. The relatively

thicker wall-section of the cushion 58 can be designed to provide structure and support to the mask 52. The cushion 58 can be provided with structure to reduce or eliminate the likelihood of the cushion 58 collapsing when the mask 52 is strapped on to a patient 50. If the cushion 58 collapses, leaks can occur and the rigid plastic mask frame 68 can be pushed against the patient's face 70 causing discomfort. Therefore, the number and size of tube paths 72 may be limited so that the structure of the cushion 58 is less likely to be compromised. The cushion 58 can include any single one or any combination of the tube paths 72 illustrated in Figure 10, for example. In some configurations, the cushion 58 can include a single tube path 72 on one side or a single tube path 72 on each side. In configurations with at least one tube path 72 on each side, the tube paths 72 can be the same size or a different size. For example, the cushion 58 can include a relatively smaller tube path 72 on one side and a relatively larger tube path 72 on the other side. In some configurations, the cushion 58 includes a small and a large tube path 72 on each side.

[0074] Typically, NG tubes 54 are run from the underside of a patient's nose across their lip and out across the cheek. The tube 54 usually is secured to the nose with tape. The one or more tube paths 72 preferably are located on the cushion 58 such that they align approximately with the lower surface of a patient's nose or somewhat lower so that the tubes 54 can be secured to the patient 50 in approximately the conventional location for ease of use by the clinician. It can be beneficial for the tube 54 to be positioned over the soft part of a patient's cheek, anywhere below the zygomatic bone, to minimize the occurrence of pressure sores. Having the tube paths 72 located in such a way on the cushion 58 will enable clinicians to continue using traditional techniques for fitting and securing NG tubes 54. In some configurations, the tube paths 72 are located in the lower half of the cushion 58 or the lower third of the cushion 58. The tube paths 72 can be located at, near or somewhat above a widest point of a full face cushion 58. In some configurations, the tube paths 72 are spaced above a lowermost point of an inner edge of the cushion 58.

[0075] Figures 11A and 11B show embodiments of a cushion module 64 of a mask 52 having visual alignment indicators 130. The indicators 130 are intended to provide clinicians with a visual cue for aligning a mask 52 over the top of an NG tube 54 on a patient's face 70. For the illustrated masks 52 to work effectively, it is desirable for the NG

tube 54 to be aligned accurately with respect to the tube paths 72 on the mask cushion 58. Misalignment may result in increased leak rates. The alignment indicators 130 can be in the form of an arrow and label that point towards the NG tube path 72. The indicator 130 may be located on the cushion 58, as illustrated in Figure 11A, or the mask body (e.g., housing 66 or frame 68), as illustrated in Figure 11B, proximate to the tube path 72. Embossing, printing, laser etching, molding or other marking techniques can be used to form the indicator 130 on the mask 52.

[0076] Unless the context clearly requires otherwise, throughout the description and the claims, the words “comprise”, “comprising”, and the like, are to be construed in an inclusive sense as opposed to an exclusive or exhaustive sense, that is to say, in the sense of “including, but not limited to”. Conditional language used herein, such as, among others, “can,” “could,” “might,” “may,” “e.g.,” and the like, unless specifically stated otherwise, or otherwise understood within the context as used, is generally intended to convey that certain embodiments include, while other embodiments do not include, certain features, elements and/or states. Thus, such conditional language is not generally intended to imply that features or elements are in any way required for one or more embodiments.

[0077] The term “plurality” refers to two or more of an item. The term “about” or “approximately” means that quantities, dimensions, sizes, formulations, parameters, shapes and other characteristics need not be exact, but may be approximated and/or larger or smaller, as desired, reflecting acceptable tolerances, conversion factors, rounding off, measurement error and the like and other factors known to those of skill in the art. The term “substantially” means that the recited characteristic, parameter, or value need not be achieved exactly, but that deviations or variations, including for example, tolerances, measurement error, measurement accuracy limitations and other factors known to those of skill in the art, may occur in amounts that do not preclude the effect the characteristic was intended to provide.

[0078] Numerical data may be expressed or presented herein in a range format. It is to be understood that such a range format is used merely for convenience and brevity and thus should be interpreted flexibly to include not only the numerical values explicitly recited as the limits of the range, but also interpreted to include all of the individual numerical values

or sub-ranges encompassed within that range as if each numerical value and sub-range is explicitly recited. As an illustration, a numerical range of “about 1 to 5” should be interpreted to include not only the explicitly recited values of about 1 to about 5, but should also be interpreted to also include individual values and sub-ranges within the indicated range. Thus, included in this numerical range are individual values such as 2, 3 and 4 and sub-ranges such as “about 1 to about 3,” “about 2 to about 4” and “about 3 to about 5,” “1 to 3,” “2 to 4,” “3 to 5,” etc. This same principle applies to ranges reciting only one numerical value (e.g., “greater than about 1”) and should apply regardless of the breadth of the range or the characteristics being described.

[0079] A plurality of items may be presented in a common list for convenience. However, these lists should be construed as though each member of the list is individually identified as a separate and unique member. Thus, no individual member of such list should be construed as a de facto equivalent of any other member of the same list solely based on their presentation in a common group without indications to the contrary. Furthermore, where the terms “and” and “or” are used in conjunction with a list of items, they are to be interpreted broadly, in that any one or more of the listed items may be used alone or in combination with other listed items. The term “alternatively” refers to selection of one of two or more alternatives, and is not intended to limit the selection to only those listed alternatives or to only one of the listed alternatives at a time, unless the context clearly indicates otherwise.

[0080] Reference to any prior art in this specification is not, and should not be taken as, an acknowledgement or any form of suggestion that that prior art forms part of the common general knowledge in the field of endeavour in any country in the world.

[0081] Where, in the foregoing description reference has been made to integers or components having known equivalents thereof, those integers are herein incorporated as if individually set forth.

[0082] The invention may also be said broadly to consist in the parts, elements and features referred to or indicated in the specification of the application, individually or collectively, in any or all combinations of two or more of said parts, elements or features.

[0083] It should be noted that various changes and modifications to the presently preferred embodiments described herein will be apparent to those skilled in the art. Such changes and modifications may be made without departing from the spirit and scope of the invention and without diminishing its attendant advantages. For instance, various components may be repositioned as desired. It is therefore intended that such changes and modifications be included within the scope of the invention. Moreover, not all of the features, aspects and advantages are necessarily required to practice the present invention. Accordingly, the scope of the present invention is intended to be defined only by the claims that follow.

WHAT IS CLAIMED IS:

1. A cushion for a respiratory mask, comprising:
a face contacting portion;
at least one thin region at least partially within the face contacting portion, the thin region adapted to accommodate the placement of a tube between the face contacting portion and a face of a user.
2. The cushion of Claim 1, wherein, in use, the at least one thin region is adapted to conform to a shape of the tube while substantially maintaining an adequate seal with the face of the user.
3. The cushion of either one of Claims 1 or 2, wherein the at least one thin region is located on a lateral side of the face contacting portion.
4. The cushion of any one of Claims 1-3, wherein the at least one thin region comprises a thin region on each lateral side of the face contacting portion.
5. The cushion of Claim 4, wherein the thin region on one lateral side is a relatively larger thin region and the thin region on the other side is a relatively smaller thin region.
6. The cushion of any one of Claims 1-5, wherein the at least one thin region comprises two or more thin regions on one lateral side of the face contacting portion.
7. The cushion of Claim 6, wherein a first thin region and a second thin region of the two or more thin regions are spaced apart from one another.
8. The cushion of Claim 7, wherein the first thin region and the second thin region are spaced apart along a perimeter of the face contacting portion.
9. The cushion of any one of Claims 6-8, wherein the two or more thin regions comprises at least one relatively larger thin region and at least one relatively smaller thin region.
10. The cushion of any one of Claims 1-9, wherein the at least one thin region extends in a direction from an inner edge of the face contacting portion toward an outer edge of the face contacting portion.

11. The cushion of any one of Claims 1-10, wherein the at least one thin region extends downwardly relative to a horizontal axis from an inner end portion to an outer end portion.

12. The cushion of Claim 11, wherein the at least one thin region extends downwardly at an angle of between about 5 degrees and about 45 degrees.

13. The cushion of any one of Claims 1-12, further comprising a smooth transition in thickness between the at least one thin region and an adjacent portion of the face contacting portion.

14. The cushion of Claim 13, wherein the transition is substantially linear.

15. The cushion of any one of Claims 1-14, wherein a thickness of the at least one thin region is between about 5 percent and about 80 percent of a thickness of an adjacent portion of the face contacting portion.

16. The cushion of Claim 15, wherein the thickness of the at least one thin region is between about 10 percent and about 30 percent of the thickness of the adjacent portion of the face contacting portion.

17. The cushion of any one of Claims 1-16, wherein end portions of the at least one thin region are rounded.

18. The cushion of any one of Claims 1-17, wherein an inner end portion of the at least one thin region is spaced outwardly from an inner edge of the face contacting portion.

19. The cushion of any one of Claims 1-18, wherein an outer end portion of the at least one thin region is spaced inwardly from an outer edge of the face contacting portion.

20. The cushion of any one of Claims 1-19, wherein the tube is a feeding tube.

21. The cushion of any one of Claims 1-20, further comprising a visual alignment indicator that indicates a proper location of the tube.

22. A patient interface, comprising:
a cushion according to any one of Claims 1-21.

23. The patient interface of Claim 22, wherein the cushion is adapted to create a seal around the user's nose and/or mouth.

24. The patient interface of either of Claims 22 or 23, wherein the cushion is configured such that an upper portion of the cushion can be deflected forward relative to a lower portion of the cushion.

25. The patient interface of any one of Claims 22-24, further comprising headgear adapted to retain the patient interface on the head of a user.

26. The patient interface of Claim 25, further comprising a frame portion adapted to interface with the headgear, wherein the cushion is adapted to interface with the frame portion.

27. The patient interface of any one of Claims 22-26, wherein the cushion comprises a relatively soft portion defining the face contacting portion and a relatively rigid portion facing away from the relatively soft portion.

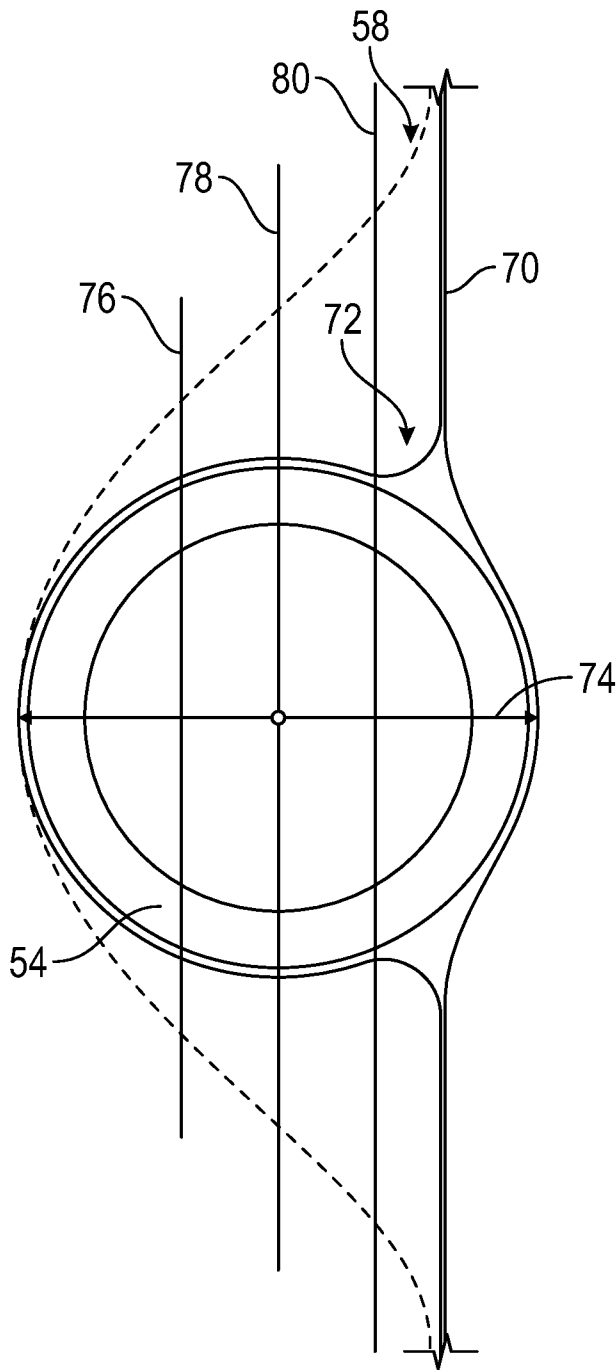

FIG. 2

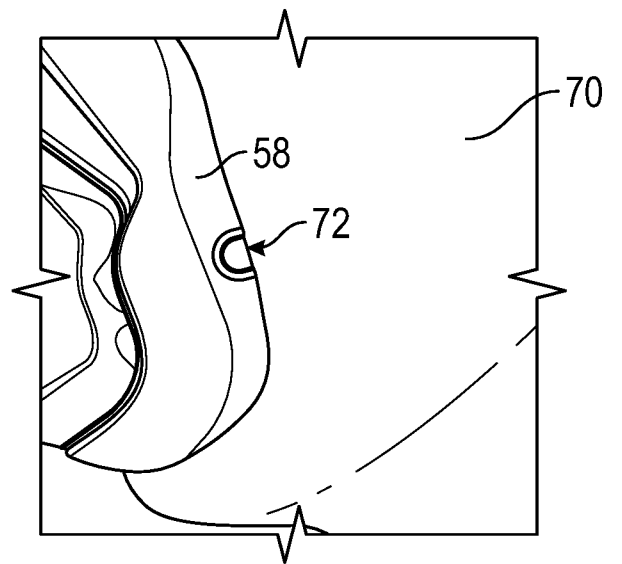

FIG. 3

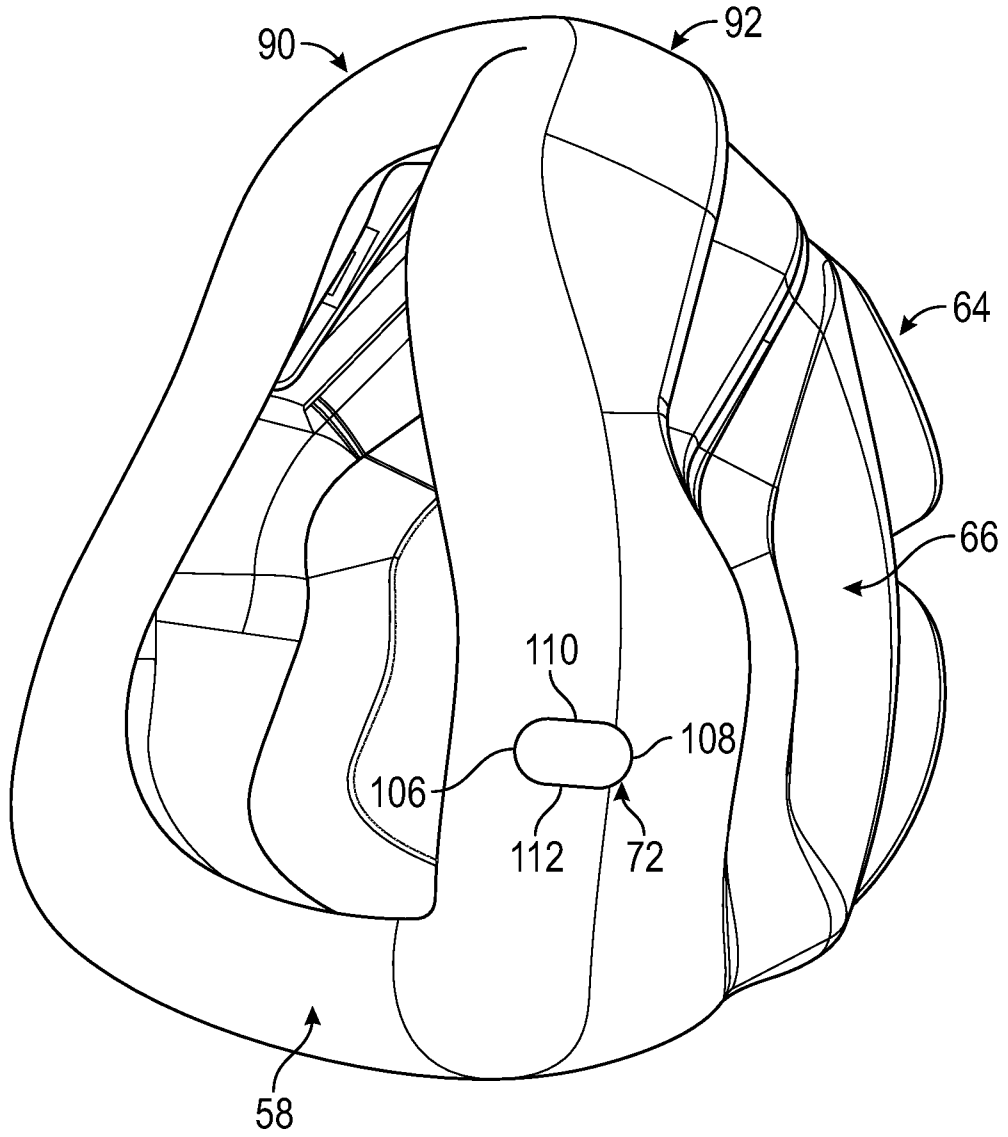

FIG. 4

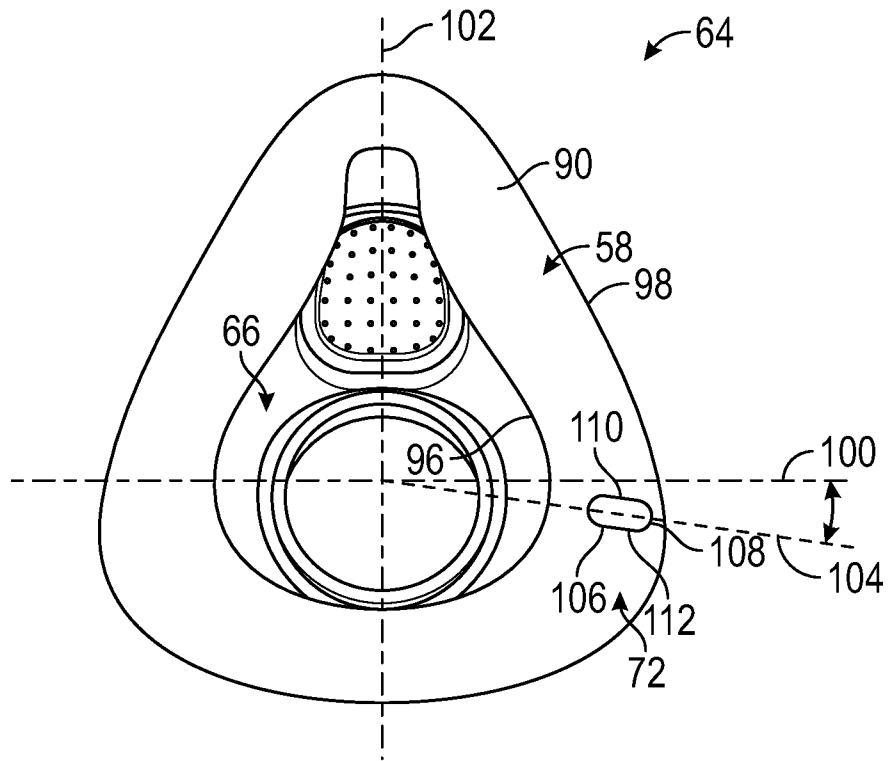

FIG. 5

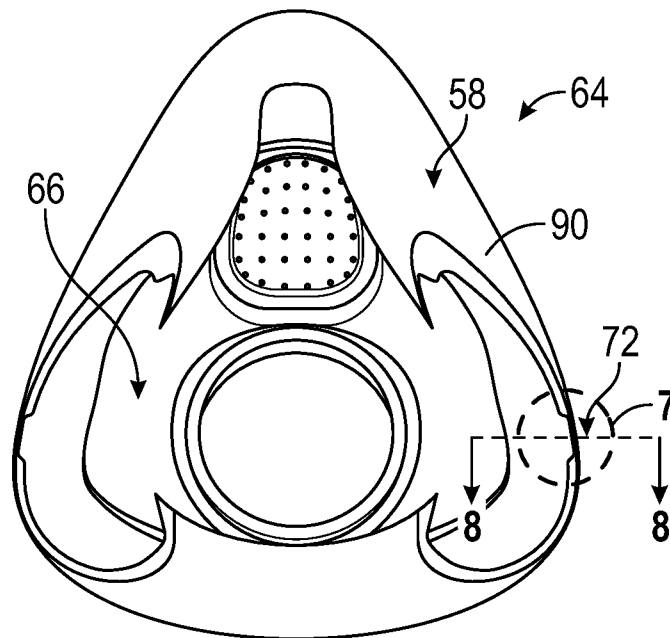

FIG. 6

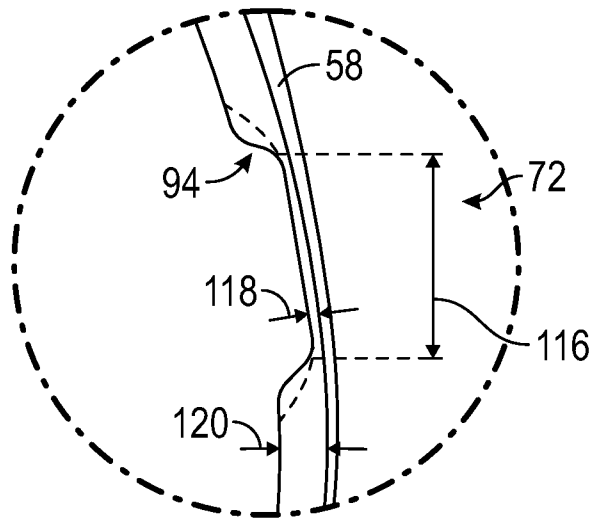

FIG. 7

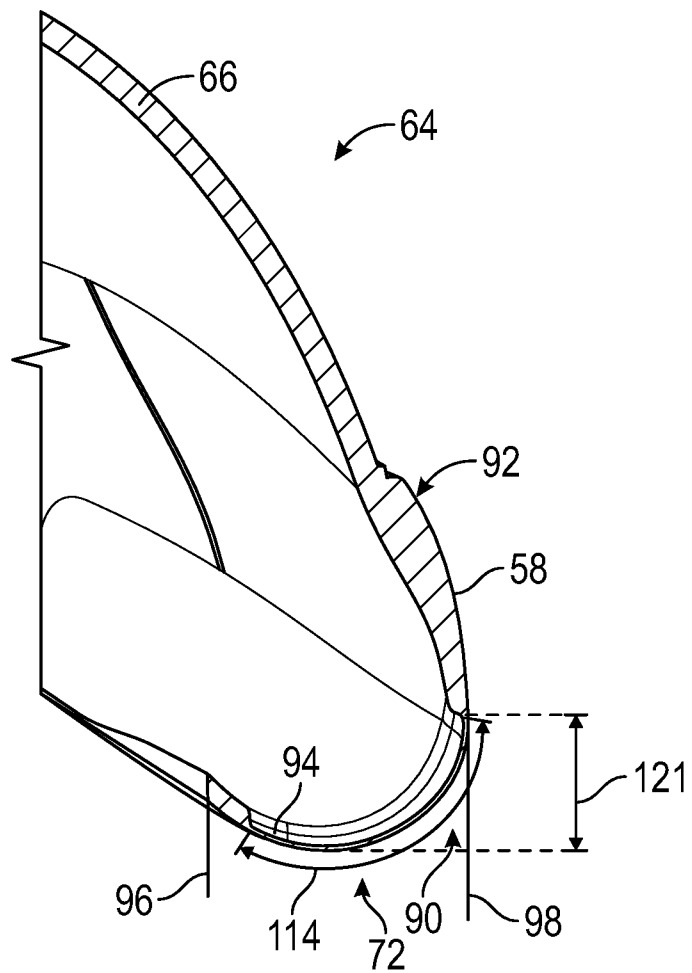

FIG. 8

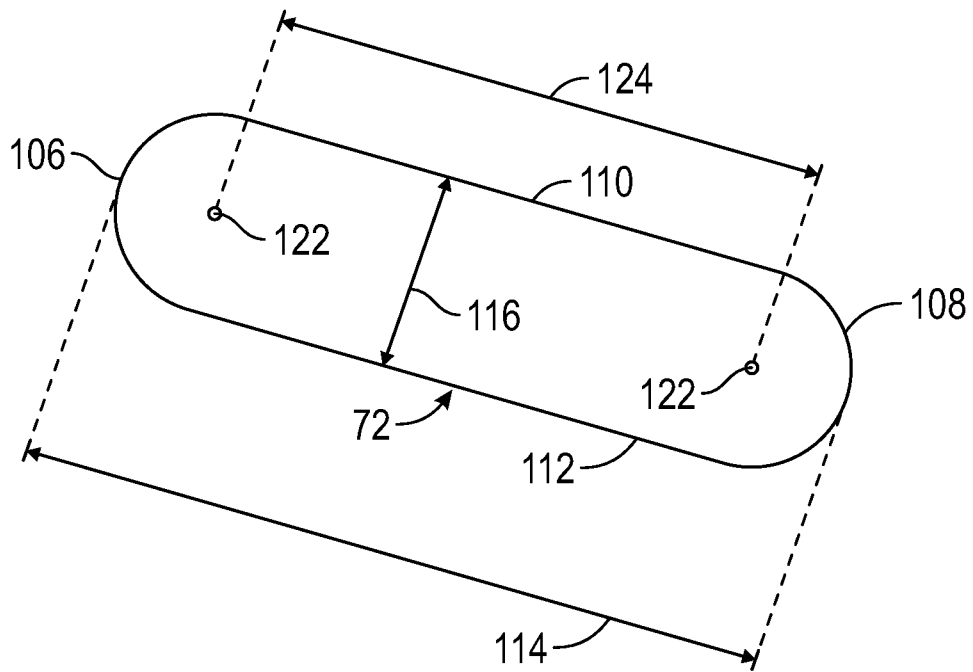

FIG. 9

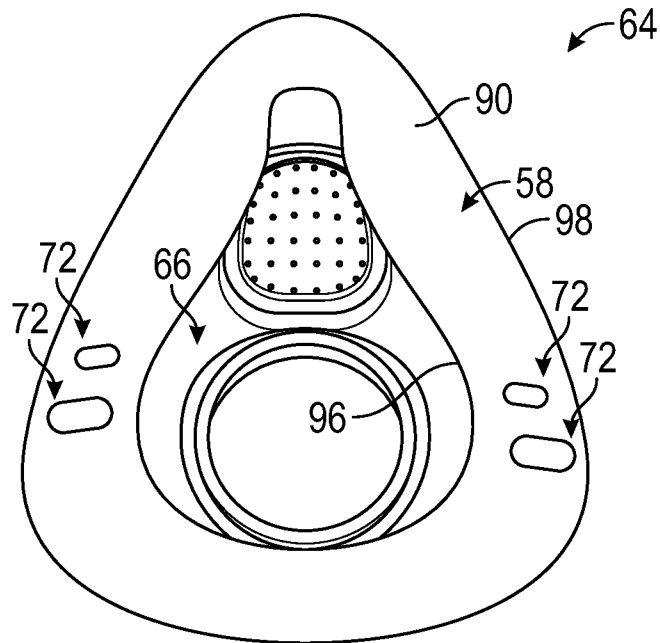

FIG. 10

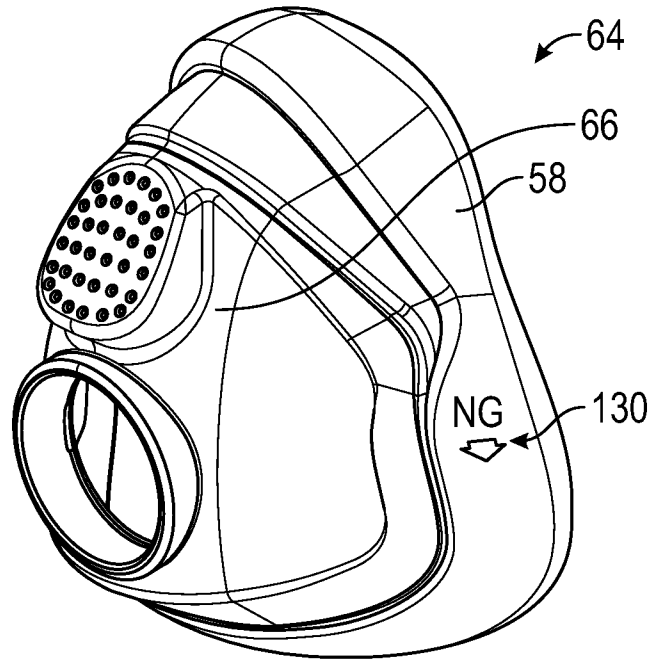

FIG. 11A

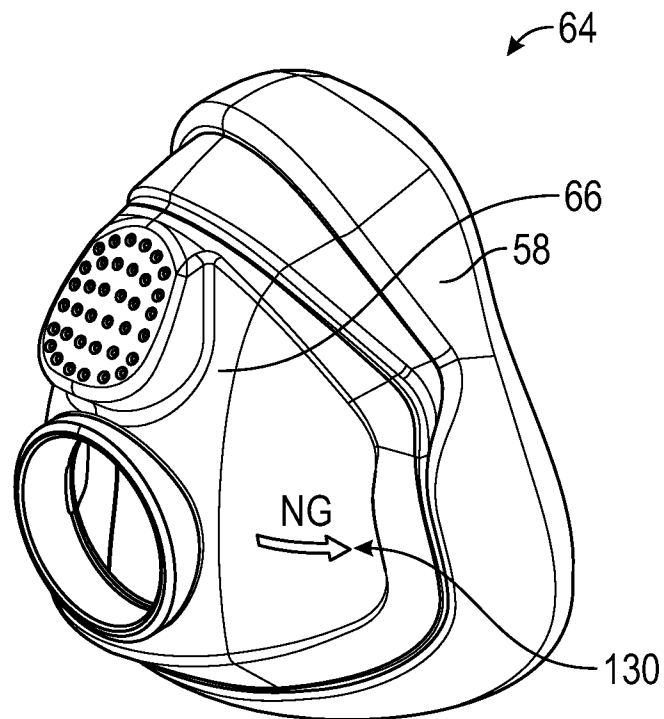

FIG. 11B

INTERNATIONAL SEARCH REPORT

International application No.
PCT/NZ2015/050019

A. CLASSIFICATION OF SUBJECT MATTER

A61M 16/06 (2006.01)

According to International Patent Classification (IPC) or to both national classification and IPC

B. FIELDS SEARCHED

Minimum documentation searched (classification system followed by classification symbols)

Documentation searched other than minimum documentation to the extent that such documents are included in the fields searched

Electronic data base consulted during the international search (name of data base and, where practicable, search terms used)

Searched in EPODOC and TXTE using the CPC marks A61M16/06, A61M16/0605, A62B18/086 and the keywords seal, tube, feeding, cushion, thin+.

Searched in Google Patents using the keywords mask, cushion, seal, tube, thin cross-section, corrugated, compliant and the like.

Searched in Google Patents using the applicant, Fisher & Paykel Healthcare Limited, and the inventor Jae Yun Lim.

C. DOCUMENTS CONSIDERED TO BE RELEVANT

Category*	Citation of document, with indication, where appropriate, of the relevant passages	Relevant to claim No.
	Documents are listed in the continuation of Box C	

 Further documents are listed in the continuation of Box C See patent family annex

* Special categories of cited documents:		
"A" document defining the general state of the art which is not considered to be of particular relevance	"T"	later document published after the international filing date or priority date and not in conflict with the application but cited to understand the principle or theory underlying the invention
"E" earlier application or patent but published on or after the international filing date	"X"	document of particular relevance; the claimed invention cannot be considered novel or cannot be considered to involve an inventive step when the document is taken alone
"L" document which may throw doubts on priority claim(s) or which is cited to establish the publication date of another citation or other special reason (as specified)	"Y"	document of particular relevance; the claimed invention cannot be considered to involve an inventive step when the document is combined with one or more other such documents, such combination being obvious to a person skilled in the art
"O" document referring to an oral disclosure, use, exhibition or other means	"&"	document member of the same patent family
"P" document published prior to the international filing date but later than the priority date claimed		

Date of the actual completion of the international search
13 April 2015Date of mailing of the international search report
13 April 2015

Name and mailing address of the ISA/AU

AUSTRALIAN PATENT OFFICE
PO BOX 200, WODEN ACT 2606, AUSTRALIA
Email address: pct@ipaustalia.gov.au

Authorised officer

Cameron Lutton
AUSTRALIAN PATENT OFFICE
(ISO 9001 Quality Certified Service)
Telephone No. 0262104084

INTERNATIONAL SEARCH REPORT

International application No.

C (Continuation).

DOCUMENTS CONSIDERED TO BE RELEVANT

PCT/NZ2015/050019

Category*	Citation of document, with indication, where appropriate, of the relevant passages	Relevant to claim No.
X Y	WO 2013/066195 A1 (FISHER & PAYKEL HEALTHCARE LIMITED) 10 May 2013 paragraphs [0274-0284], figs. 1-2, 62-65 paragraphs [0274-0284], figs. 62-65	1-2, 10-15, 22-27 3-9 and 16-21
Y	US 2012/0285448 A1 (DUGAN et al.) 15 November 2012 abstract, paragraphs [0068-0070, 0192-0194], fig. 6, 26 a-c,	3-9 and 16-21
Y	US 2013/0192601 A1 (REISCHL et al.) 01 August 2013 paragraphs [0023-0025], fig 3	3-9 and 16-21
A	US 2004/0244799 A1 (LANDIS) 09 December 2004	
A	US 2007/0107733 A1 (HO et al.) 17 May 2007	

INTERNATIONAL SEARCH REPORT

Information on patent family members

International application No.

PCT/NZ2015/050019

This Annex lists known patent family members relating to the patent documents cited in the above-mentioned international search report. The Australian Patent Office is in no way liable for these particulars which are merely given for the purpose of information.

Patent Document/s Cited in Search Report		Patent Family Member/s	
Publication Number	Publication Date	Publication Number	Publication Date
WO 2013/066195 A1	10 May 2013	AU 2012241516 A1	31 Oct 2013
		AU 2012331716 A1	01 May 2014
		CA 2833106 A1	18 Oct 2012
		CA 2852636 A1	10 May 2013
		CN 103619393 A	05 Mar 2014
		CN 103945890 A	23 Jul 2014
		EP 2696926 A1	19 Feb 2014
		EP 2758113 A1	30 Jul 2014
		FR 2981853 A1	03 May 2013
		GB 2503843 A	08 Jan 2014
		JP 2014517735 A	24 Jul 2014
		JP 2014534030 A	18 Dec 2014
		US 2014096774 A1	10 Apr 2014
		US 2014283842 A1	25 Sep 2014
		WO 2012140514 A1	18 Oct 2012
US 2012/0285448 A1	15 November 2012	US 8915250 B2	23 Dec 2014
		CA 2835491 A1	15 Nov 2012
		CN 103702706 A	02 Apr 2014
		EP 2707071 A2	19 Mar 2014
		JP 2014516672 A	17 Jul 2014
		MX 2013013159 A	27 May 2014
		US 2012285467 A1	15 Nov 2012
		US 8695602 B2	15 Apr 2014
		US 2012285461 A1	15 Nov 2012
		US 8783252 B2	22 Jul 2014
		US 2012285466 A1	15 Nov 2012
		US 8881730 B2	11 Nov 2014
		US 2012285468 A1	15 Nov 2012
		US 8887727 B2	18 Nov 2014
		US 2012285464 A1	15 Nov 2012
		US 8905028 B2	09 Dec 2014
		US 2012285462 A1	15 Nov 2012
US 8910635 B2	16 Dec 2014		
US 2012285465 A1	15 Nov 2012		
US 8925548 B2	06 Jan 2015		

Due to data integration issues this family listing may not include 10 digit Australian applications filed since May 2001.

Form PCT/ISA/210 (Family Annex)(July 2009)

INTERNATIONAL SEARCH REPORT

Information on patent family members

International application No.

PCT/NZ2015/050019

This Annex lists known patent family members relating to the patent documents cited in the above-mentioned international search report. The Australian Patent Office is in no way liable for these particulars which are merely given for the purpose of information.

Patent Document/s Cited in Search Report		Patent Family Member/s	
Publication Number	Publication Date	Publication Number	Publication Date
		US 2012285457 A1	15 Nov 2012
		US 8944059 B2	03 Feb 2015
		US 2012285455 A1	15 Nov 2012
		US 8944060 B2	03 Feb 2015
		US 2012285463 A1	15 Nov 2012
		US 2012289838 A1	15 Nov 2012
		US 2012289851 A1	15 Nov 2012
		WO 2012154883 A2	15 Nov 2012
US 2013/0192601 A1	01 August 2013		
US 2004/0244799 A1	09 December 2004	EP 1484075 A1	08 Dec 2004
US 2007/0107733 A1	17 May 2007	US 8051855 B2	08 Nov 2011
		AU 2006315166 A1	24 May 2007
		BR PI0618433 A2	30 Aug 2011
		CA 2629168 A1	24 May 2007
		CN 101309727 A	19 Nov 2008
		CN 101309727 B	31 Oct 2012
		EP 1948322 A2	30 Jul 2008
		JP 2009515672 A	16 Apr 2009
		JP 4995832 B2	08 Aug 2012
		WO 2007059504 A2	24 May 2007

End of Annex