



HU000027368T2

(19) **HU**(11) Lajstromszám: **E 027 368**(13) **T2****MAGYARORSZÁG**  
Szellemi Tulajdon Nemzeti Hivatala**EURÓPAI SZABADALOM**  
**SZÖVEGÉNEK FORDÍTÁSA**

- (21) Magyar ügyszám: **E 10 173906**
- (22) A bejelentés napja: **2010. 08. 24.**
- (96) Az európai bejelentés bejelentési száma:  
**EP 20100173906**
- (97) Az európai bejelentés közzétételi adatai:  
**EP 2289608 A2**                      **2011. 03. 02.**
- (97) Az európai szabadalom megadásának meghirdetési adatai:  
**EP 2289608 B1**                      **2016. 02. 17.**
- (51) Int. Cl.: **B01D 45/02**                      (2006.01)  
**B01D 46/10**                      (2006.01)  
**B01D 53/86**                      (2006.01)  
**F23J 15/02**                      (2006.01)

(30) Elsőbbségi adatok: <b>547040</b> <b>2009. 08. 25.</b> <b>US</b>	(73) Jogosult(ak): <b>The Babcock &amp; Wilcox Company, Barberton, OH 44203-0351 (US)</b>
(72) Feltaláló(k): <b>Lannacchione, Steven P., Ohio 44614 (US)</b>	(74) Képviselő: <b>Danubia Szabadalmi és Jogi Iroda Kft., Budapest</b>

- (54) **Rendszer és eljárás SCR katalizátor nagy részecskeméretű hamutól való védelmére**

Az európai szabadalom ellen, megadásának az Európai Szabadalmi Közlönyben való meghirdetésétől számított kilenc hónapon belül, felszólalást lehet benyújtani az Európai Szabadalmi Hivatalnál. (Európai Szabadalmi Egyezmény 99. cikk(1))

A fordítást a szabadalmas az 1995. évi XXXIII. törvény 84/H. §-a szerint nyújtotta be. A fordítás tartalmi helyességét a Szellemi Tulajdon Nemzeti Hivatala nem vizsgálta.



(11) **EP 2 289 608 B1**

(12) **EUROPEAN PATENT SPECIFICATION**

(45) Date of publication and mention  
of the grant of the patent:  
**17.02.2016 Bulletin 2016/07**

(51) Int Cl.:  
**B01D 45/02<sup>(2006.01)</sup> B01D 46/10<sup>(2006.01)</sup>**  
**B01D 53/86<sup>(2006.01)</sup> F23J 15/02<sup>(2006.01)</sup>**

(21) Application number: **10173906.8**

(22) Date of filing: **24.08.2010**

(54) **SYSTEM AND METHOD FOR PROTECTING A SCR CATALYST FROM LARGE PARTICLE ASH**

SYSTEM UND VERFAHREN ZUM SCHUTZ EINES SCR-KATALYSATORS VOR GROßEN  
ASCHEPARTIKELN

SYSTÈME ET PROCÉDÉ POUR PROTÉGER UN CATALYSEUR SCR CONTRE GRANDES  
PARTICULES DE CENDRE

(84) Designated Contracting States:  
**AL AT BE BG CH CY CZ DE DK EE ES FI FR GB  
GR HR HU IE IS IT LI LT LU LV MC MK MT NL NO  
PL PT RO SE SI SK SM TR**

(30) Priority: **25.08.2009 US 547040**

(43) Date of publication of application:  
**02.03.2011 Bulletin 2011/09**

(73) Proprietor: **The Babcock & Wilcox Company  
Barberton, OH 44203-0351 (US)**

(72) Inventor: **Lannacchione, Steven P.  
Ohio 44614 (US)**

(74) Representative: **D Young & Co LLP  
120 Holborn  
London EC1N 2DY (GB)**

(56) References cited:  
**EP-A1- 0 709 127 EP-A2- 1 855 056**  
**WO-A1-2004/001290 WO-A1-2005/114053**  
**DE-A1- 3 642 178 DE-A1- 3 732 651**  
**DE-A1- 4 436 207 US-A- 4 915 920**  
**US-A- 5 943 865 US-A1- 2005 061 261**

**EP 2 289 608 B1**

Note: Within nine months of the publication of the mention of the grant of the European patent in the European Patent Bulletin, any person may give notice to the European Patent Office of opposition to that patent, in accordance with the Implementing Regulations. Notice of opposition shall not be deemed to have been filed until the opposition fee has been paid. (Art. 99(1) European Patent Convention).

**Description**

## FIELD

5 **[0001]** The present invention relates generally to the field of emission control equipment for boilers, heaters, kilns, or other flue gas-, or combustion gas-, generating devices (e.g., those located at power plants, processing plants, etc.) and, in particular but not exclusively to a new and useful method and apparatus for preventing the plugging, blockage and/or contamination of an SCR catalyst. In another embodiment, the method and apparatus of the present invention is designed to protect an SCR catalyst from plugging and/or blockage from large particle ash that may be generated during combustion.

## BACKGROUND

15 **[0002]** NO<sub>x</sub> refers to the cumulative emissions of nitric oxide (NO), nitrogen dioxide (NO<sub>2</sub>) and trace quantities of other nitrogen oxide species generated during combustion. Combustion of any fossil fuel generates some level of NO<sub>x</sub> due to high temperatures and the availability of oxygen and nitrogen from both the air and fuel. NO<sub>x</sub> emissions may be controlled using low NO<sub>x</sub> combustion technology and post-combustion techniques. One such post-combustion technique is selective catalytic reduction using an apparatus generally referred to as a selective catalytic reactor or simply as an SCR.

20 **[0003]** SCR technology is used worldwide to control NO<sub>x</sub> emissions from combustion sources. This technology has been used widely in Japan for NO<sub>x</sub> control from utility boilers since the late 1970's, in Germany since the late 1980's, and in the US since the 1990's. The function of the SCR system is to react NO<sub>x</sub> with ammonia (NH<sub>3</sub>) and oxygen to form molecular nitrogen and water. Industrial scale SCRs have been designed to operate principally in the temperature range of 500°F to 900°F, but most often in the range of 550°F to 750°F. SCRs are typically designed to meet a specified NO<sub>x</sub> reduction efficiency at a maximum allowable ammonia slip. Ammonia slip is the concentration, expressed in parts per million by volume, of unreacted ammonia exiting the SCR.

25 **[0004]** For additional details concerning NO<sub>x</sub> removal technologies used in the industrial and power generation industries, the reader is referred to Steam: its generation and use, 41st Edition, Kitto and Stultz, Eds., Copyright © 2005, The Babcock & Wilcox Company, Barberton, Ohio, U.S.A., particularly Chapter 34 - Nitrogen Oxides Control.

30 **[0005]** Regulations (March 2005) issued by the EPA promise to increase the portion of utility boilers equipped with SCRs. SCRs are generally designed for a maximum efficiency of about 90%. This limit is not set by any theoretical limits on the capability of SCRs to achieve higher levels of NO<sub>x</sub> destruction. Rather, it is a practical limit set to prevent excessive levels of ammonia slip. This problem is explained as follows.

**[0006]** In an SCR, ammonia reacts with NO<sub>x</sub> according to the following stoichiometric reactions (a) to (c):

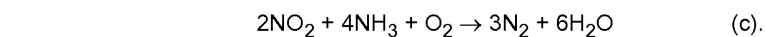
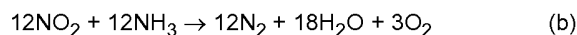
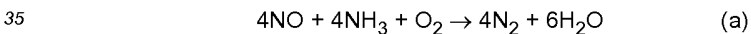

**[0007]** The above reactions are catalyzed using a suitable catalyst. Suitable catalysts are discussed in, for example, United States Patent Nos. 5,540,897; 5,567,394; and 5,585,081 to Chu et al. Catalyst formulations generally fall into one of three categories: base metal, zeolite and precious metal.

45 **[0008]** Base metal catalysts use titanium oxide with small amounts of vanadium, molybdenum, tungsten or a combination of several other active chemical agents. The base metal catalysts are selective and operate in the specified temperature range. The major drawback of the base metal catalyst is its potential to oxidize SO<sub>2</sub> to SO<sub>3</sub>; the degree of oxidation varies based on catalyst chemical formulation. The quantities of SO<sub>3</sub> which are formed can react with the ammonia carryover to form various ammonium-sulfate salts.

50 **[0009]** Zeolite catalysts are aluminosilicate materials which function similarly to base metal catalysts. One potential advantage of zeolite catalysts is their higher operating temperature of about 970°F (521 °C). These catalysts can also oxidize SO<sub>2</sub> to SO<sub>3</sub> and must be carefully matched to the flue gas conditions.

55 **[0010]** Precious metal catalysts are generally manufactured from platinum and rhodium. Precious metal catalysts also require careful consideration of flue gas constituents and operating temperatures. While effective in reducing NO<sub>x</sub>, these catalysts can also act as oxidizing catalysts, converting CO to CO<sub>2</sub> under proper temperature conditions. However, SO<sub>2</sub> oxidation to SO<sub>3</sub> and high material costs often make precious metal catalysts less attractive.

**[0011]** As is known to those of skill in the art, various SCR catalysts undergo plugging and/or poisoning when they become contaminated by various compounds including but not limited to, ash from the combustion process (in particular coal ash). One common source of plugging in SCRs is large particle ash (typically defined as any ash that has a particle

size large enough to lodge in the catalyst passages, pores, or honeycomb structure present in the SCR catalyst blocks).

**[0012]** Given the above, a need exists for a system and method that can impede, reduce or prevent the plugging and/or poisoning of a catalyst in an SCR with fly ash, particularly large particle ash.

**[0013]** US 2005/0061261 A1 describes a coal-fired power station which is heated by dry firing and which comprises a boiler which is connected to a denitrification catalyst by means of a smoke-gas channel. A coarse ash separator is arranged on the transition point between an ash funnel of the boiler and a horizontal section of the smoke-gas channel, said coarse ash separator comprising an oscillatingly suspended sieve and a stop defining the neutral position of the sieve. The smoke-gas channel sets the sieve in a pendular motion, whereby coarse ash particles are separated from the sieve and pass into the ash funnel.

**[0014]** WO2005/114053 describes a device for separating particles from a flue gas flow having a horizontal flue gas duct, through which flow passes substantially horizontally from a first position to a second position. In the first position, the device has a baffle arrangement with at least one plate which is arranged in the flue gas duct and is inclined so as to deflect particles down to the lower portion of the flue gas duct. In the second position, the device has a collecting means, which is arranged in the lower portion of the flue gas duct to collect the particles which have been deflected downwards by the plate to the lower portion of the flue gas duct.

SUMMARY

**[0015]** Particular aspects of the invention are defined in the claims.

**[0016]** The present invention relates generally to the field of emission control equipment for boilers, heaters, kilns, or other flue gas-, or combustion gas-, generating devices (e.g., those located at power plants, processing plants, etc.) and, in particular to a new and useful method and apparatus for preventing the plugging, blockage and/or contamination of an SCR catalyst. In some arrangements, the method and apparatus of the present invention is designed to protect an SCR catalyst from plugging and/or blockage from large particle ash that may be generated during combustion.

**[0017]** Accordingly, viewed from one aspect, there can be provided a system for increasing the active life of an SCR catalyst, the system comprising: (i) at least one first flue gas conduit designed to transport flue gas from a combustion zone to an SCR; (ii) at least one SCR positioned between the at least one first flue gas conduit and at least one second flue gas conduit, wherein the at least one second flue gas conduit is designed to transport flue gas from the SCR to additional downstream systems or environmental controls; (iii) at least one large particle ash screen positioned in the at least one first flue conduit so as to enable the collection of at least about 50 percent of any large particle ash present in the flue gas prior to the entry of the flue gas into the at least one SCR; and (iv) at least one rotary valve positioned to be in working communication with the large particle ash screen, wherein the at least one rotary valve is designed to collect any large particle ash captured by the at least one large particle ash screen and supply such large particle ash to the at least one second flue gas conduit.

**[0018]** Viewed from another aspect there can be provided a system for increasing the active life of an SCR catalyst, the system comprising: (A) at least one first flue gas conduit designed to transport flue gas from a combustion zone to an SCR, the at least one first flue gas conduit being designed to permit the flue gas to flow at a first flow velocity; (B) at least one second flue gas conduit that is in operative communication with the at least one first flue gas conduit, wherein the at least one second flue gas conduit is designed to transport flue gas from the at least one first flue gas conduit to an SCR, the at least one second flue gas conduit being designed to permit the flue gas to flow at a second flow velocity, and the second flow velocity is at least 10 percent less than the first flow velocity; (C) at least one third flue gas conduit designed to transport flue gas from the SCR to additional downstream systems or environmental controls; and (D) at least one rotary valve positioned to be in working communication with the at least one second flue gas conduit, wherein the at least one rotary valve is designed to collect any large particle ash captured in the at least one second flue gas conduit and supply such large particle ash to the at least one third flue gas conduit, wherein the combination of the at least one second flue gas conduit and the at least one rotary valve enable the collection of at least about 50 percent of any large particle ash present in the flue gas prior to the entry of the flue gas into the at least one SCR.

**[0019]** Viewed from yet another aspect there can be provided a method for increasing the active life of an SCR catalyst, the method comprising the steps of: (a) providing at least one large particle ash collection means designed to collect large particle ash in a flue gas stream upstream of the entry of the flue gas into an SCR; and (b) collecting the large particle ash in the at least one large particle ash collection means so as to remove at least about 50 percent of the large particle ash from the flue gas stream prior to entry of the flue gas stream into the SCR; and (c) supplying the collected large particle ash to a point in the flue gas stream downstream of the SCR.

**[0020]** The various features of novelty provided by the invention are pointed out with particularity in the claims annexed to and forming a part of this disclosure. For a better understanding of the invention, its operating advantages and specific benefits attained by its uses, reference is made to the accompanying drawings and descriptive matter in which example embodiments of the invention are illustrated.

BRIEF DESCRIPTION OF THE DRAWINGS

**[0021]** Specific embodiments will now be described, by way of example only, with reference to the accompanying drawings in which:

5

Fig. 1 is a schematic representation of a typical fossil fuel burning facility, designed and initially provided with an SCR system;

10

Fig. 2 is a schematic representation of another typical fossil fuel burning facility which was not designed or initially provided with an SCR system;

Fig. 3 is a schematic representation of the fossil fuel burning facility of Fig. 2, to which SCR equipment in accordance with the present disclosure has been added;

15

Fig. 4 is a close up, perspective view illustrating the arrangement of the flues from the boiler and the lower outlet portion of the SCR of Fig. 3, in accordance with one embodiment;

20

Fig. 5 is a side view of the arrangement of the flues from the boiler and the lower outlet portion of the SCR of Fig. 4, in accordance with one embodiment; and

Fig. 6 is a cross-sectional view of the arrangement of the flues from the boiler and the lower outlet portion of the SCR of Fig. 4, viewed in the direction of arrows 6 - 6 of Fig. 3.

25

**[0022]** While the invention is susceptible to various modifications and alternative forms, specific embodiments are shown by way of example in the drawings and are herein described in detail. It should be understood, however, that drawings and detailed description thereto are not intended to limit the invention to the particular form disclosed, but on the contrary, the invention is to cover all modifications, equivalents and alternatives falling within the spirit and scope of the present invention as defined by the appended claims.

30

DETAILED DESCRIPTION

35

**[0023]** While the present discussion is provided in terms of SCR systems which use ammonia as the NO<sub>x</sub> reducing agent, since ammonia is frequently preferred for economic reasons, the present invention is not limited to ammonia based systems. The concepts of the present invention can be used in any system which uses an ammoniacal compound. As used in the present disclosure, an ammoniacal compound is a term meant to include compounds such as urea, ammonium sulfate, cyanuric acid, and organic amines as well as ammonia (NH<sub>3</sub>). These compounds could be used as reducing agents in addition to ammonia, but as mentioned above, ammonia is frequently selected for economic reasons. Some non-ammoniacal compounds such as carbon monoxide or methane can be used as well, but with a possible reduction in effectiveness.

40

**[0024]** Although the present discussion is provided in relation to a boiler, or a fossil fuel boiler, the invention is not limited solely thereto. Instead, the present invention can be applied to any combustion source that generates NO<sub>x</sub> regardless of whether such a combustion source is utilized in conjunction with a boiler, or a steam generator. For example, the present invention could be used in combination with a kiln, a heater, or any other type of combustion process that generates, in whole or in part, a flue gas or combustion gas containing NO<sub>x</sub>. Accordingly, the description below is to be construed as merely by way of example. Additionally, the present invention can be applied to any SCR regardless of the type of catalyst that is utilized therein. As such, the present invention is not limited to any one type of SCR catalyst, but rather is broadly applicable to a wide range of SCR catalyst systems. Suitable catalyst systems include, but are not limited to, honeycomb, corrugated and plate-type catalysts.

45

50

**[0025]** One embodiment of the present disclosure is directed to reducing the rate of SCR catalyst deactivation on Powder River Basin (PRB) coal combustion units. It should be noted that although the present disclosure is described in relation to PRB coal, the present invention is not limited thereto. Rather, the present invention is broadly applicable to any situation where an SCR catalyst is plugged, blocked and/or contaminated by large particle ash (LPA) that accumulates in the catalyst passages, pores, or honeycomb structure present in the SCR catalyst blocks.

55

**[0026]** In one embodiment, PRB coal is suspected to cause plugging, blockage and/or contamination of the catalyst passages, pores, or honeycomb structure present in the SCR catalyst blocks due to the presence of LPA which can be considered to be, in a non-limiting manner, popcorn ash. While not wishing to be bound to any one definition, LPA is defined as ash having a mean particle size of at least about 4 mm, or even at least about 6 mm. In one embodiment, LPA has any type of geometry including, but not limited to, irregular geometries, spherical geometries, oblong geometries,

ellipsoidal geometries, or any combination of two or more thereof. In another embodiment, LPA is defined as any ash that is larger than the catalyst passages, pores, or honeycomb structure present in the SCR catalyst blocks. In this embodiment, the size of the LPA only has to be sufficient to cause plugging, blockage and/or contamination of the catalyst in the SCR.

5 **[0027]** In one embodiment, the present disclosure relates to a system and method to prevent plugging, blockage and/or contamination of the catalyst passages, pores, or honeycomb structure present in the SCR catalyst blocks due to the presence of LPA. In one embodiment, the present disclosure addresses the aforementioned goal by the addition of at least one LPA screen and at least one rotary valve located at a position in the flue conduit downstream of the boiler but upstream of the SCR designed to remove at least about 50 percent of the LPA present in the flue gas stream. In other  
10 embodiments, the present disclosure provides for removal of at least about 75 percent, at least about 85 percent, at least about 95 percent, or even at least about 99 percent of the LPA in the flue gas stream. Here, as elsewhere in the present disclosure, individual range limits can be combined to form new and/or undisclosed ranges.

**[0028]** Turning to the Figures, Fig. 1 is an illustration of a typical power plant that utilizes coal as a combustion source, and which was designed and initially provided with an SCR system. As can be seen in Fig. 1, a typical power plant  
15 includes a SCR located between a boiler portion of the power plant and a spray dry absorber (SDA). The SDA is used to remove sulfur oxides from the flue gas produced during the combustion process in the boiler portion. In another typical configuration, illustrated in Fig. 2, which was not designed or initially provided with an SCR system, the flue gases from the boiler are conveyed through at least one flue to an air heater (in Fig. 2, a tubular air heater) and then to downstream particle collection devices such as an electrostatic precipitator or ESP as shown, without any type of system to remove  
20 any LPA present in the flue gas from the flue gas stream. As a consequence of this, if an SCR were to be added, the LPA produced during the combustion process in the boiler could cause plugging, blockage and/or contamination of the catalyst passages, pores, or honeycomb structure present in the SCR catalyst blocks due to the presence of LPA.

**[0029]** As is noted above, the present disclosure provides approaches to address this problem through the use of at least one LPA screen and/or at least one rotary valve located at a position in the flue conduit downstream of the boiler but upstream of the SCR and designed to remove at least about 50 percent of the LPA present in the flue gas stream. In one embodiment, as is illustrated in Figs. 3, 4 and 5, a system 100 of comprises at least one LPA screen 102 and at least one rotary valve 104 that are positioned along a flue conduit 106 downstream of the boiler 108 but upstream of the SCR reactor or SCR 110 so as to remove at least about 50 percent of the LPA present in the flue gas stream. In one particular embodiment, the SCR unit 110 and an SCR outlet flue 112 therefrom are positioned in such a manner  
30 that the LPA collected from the flue gas prior to entry of the flue gas into the SCR 110 can be diverted and supplied to the SCR outlet flue 112. As can be seen from Figs. 3, 4 and 5, LPA screen 102 is provided at any suitable incline so as to cause LPA impacting LPA screen 102 to fall toward the at least one rotary valve 104. Additionally, LPA screen 102 is formed across the entire cross-section of flue conduit 106 so that any LPA present in the flue gas stream contained in conduit 106 is caused to attempt to "pass through" LPA screen 102.

**[0030]** As can be seen in Figs. 3, 4, 5 and 6, there can be multiple conduits 106 that transport flue gas from boiler 108 to SCR 110. In this case, each conduit 106 has a LPA screen 102 and at least one rotary valve 104 as described above. As can be seen in Fig. 4, each rotary valve is connected to a hopper designed to funnel LPA to a respective rotary valve. In either of these embodiments, the SCR outlet flue, or flues, 112 is/are designed to transport the SCR-treated flue gas and "added" LPA to additional downstream systems and/or environmental controls (e.g., an air heater, an SDA, or a  
40 baghouse, precipitator or other particle control device).

**[0031]** In another embodiment, the at least one LPA screen 102 can be eliminated from the system in the instance where the flue conduits that transport the flue gas from the boiler to the SCR are designed in such a manner as to contain a reduced velocity zone. The reduced velocity zone is an area in the flue conduit where the flue conduit size is altered in such a manner as to result in a sufficient reduction in the velocity of the flue gas thereby causing the LPA present in the flue gas to "fall out" and collect in the hopper so that it can be conveyed therefrom via the one or more appropriately  
45 positioned rotary valves. This embodiment is illustrated in Fig. 6 where system 200 comprises an inlet flue conduit 202 that supplies flue gas to a low velocity area 204 having a cross-section and/or volume that is sufficiently larger than conduit 202 so as to cause a suitable reduction in flue gas velocity, thereby resulting in the "fall out" of a suitable amount of LPA. In the embodiment of Fig. 6, the SCR is split into two sections, sections 206 and 208, placed on either side of an LPA collection area 210 located therebetween. As can be seen in Fig. 6, low velocity area 204 (which is also an LPA collection area) contains at least one rotary valve 212 connected thereto. As can be seen in Fig. 6, each rotary valve 212 is positioned at a hopper designed to funnel LPA to a respective rotary valve 212. As with the other embodiments of the present disclosure, the one or more rotary valves 212 are designed to convey collected LPA and "add" the LPA back into the flue gas after the flue gas is treated in the SCR and exits the one or more SCR sections via flue conduit  
50 214. The flue gas is then permitted to travel on to additional downstream systems and/or environmental controls (e.g., an air heater, an SDA, or a fabric filter, precipitator or other particle control device).

**[0032]** A non-limiting example of a reduced velocity embodiment would involve a flue gas stream that has a speed of about 50 feet per second after exiting the boiler, where such a flue gas stream is then slowed down by way of supplying

the flue gas to a flue conduit having a larger cross-sectional area. This in turn causes at least about 50 percent of the LPA present in the flue gas stream to "drop out" due to the reduced flow speed that occurs when the flue gas travels from a high flow velocity area to a lower flow velocity area. In this embodiment the area in the flue conduit with the larger cross-sectional area further comprises one or more rotary valves designed to collect and supply the LPA to a conduit downstream of the SDA so that the LPA can be collected at a suitable point after bypassing the SDA. In another embodiment, this arrangement is designed to remove at least about 75 percent, at least about 85 percent, at least about 95 percent, or even at least about 99 percent of the LPA present in the flue gas stream. Here, as well as elsewhere in the specification and claims, individual range limits can be combined or altered to form new and/or hybrid ranges not explicitly disclosed.

**[0033]** In another embodiment, the "velocity drop" achieved from the high velocity flue conduit to the low velocity flue conduit is at least about a 10 percent reduction in flue gas velocity. In still another embodiment, the "velocity drop" achieved from the high velocity flue conduit to the low velocity flue conduit is at least about a 20 percent, at least about a 30 percent, at least about a 40 percent, or even at least about a 50 percent reduction in flue gas velocity. Here, as well as elsewhere in the specification and claims, individual range limits can be combined to form new and/or hybrid ranges not explicitly disclosed. If desired, this embodiment can further include a LPA screen. Regarding the LPA screen of either embodiment, such a screen can be made from any suitable material that can withstand exposure to the conditions typically found in the flue gas stream as it exits the boiler. Suitable materials from which a LPA screen, or screens, can be formed from include, but are not limited to, one or more metals, one or more metal alloys, one or more ceramic compositions, or any suitable combination of two or more thereof. In one embodiment, the LPA screen of the present disclosure is formed from a mesh. In another embodiment, the LPA screen can be a plate structure in which suitably sized openings are formed therein. In some embodiments, the openings in the LPA screen should be sized in such a manner so as to prevent the passage of LPA therethrough. In one embodiment, the openings in an LPA screen, or LPA plate, have a cross-sectional area of no more than about 38.5 mm<sup>2</sup>, no more than about 28.3 mm<sup>2</sup>, no more than about 19.6 mm<sup>2</sup>, or even no more than about 12.6 mm<sup>2</sup>. In still another embodiment, any LPA screen of the present disclosure can be replaced by multiple LPA screens that are arranged in series along the flow direction, respectively up- and downstream from one another. In this embodiment, each successive LPA screen could contain smaller openings there through so as to progressively and selectively remove LPA from a flue gas stream prior to entry of the flue gas stream to an SCR.

**[0034]** The flue gas static pressure upstream of the SCR (and thus at the inlets of the rotary valves on the hoppers on the inlet flues) will be higher than the flue gas static pressure on the downstream side of the SCR at the discharge (and thus at the outlets of the rotary valves connected to the outlet flues), due to the pressure drop through the SCR catalyst modules and associated flues. Rotary valves are thus used in the present disclosure because they are able to transport material between regions at different pressures. The rotary valves utilized in conjunction with the present disclosure are known in the art and, as such, an exhaustive discussion of same and their principles of operation herein are omitted for the sake of brevity. A suitable example of a rotary valve that can be used is a bottom discharge type rotary valve, available from Ricon Engineers, 6-A, Archana Industrial Estate, Opp. Ajit Mill, Rakhial, Ahmedabad - 380023, Gujarat (INDIA).

**[0035]** The teachings of the present disclosure are advantageous in that they are applicable to installations with existing SCRs (retrofits) and new SCRs. Additionally, the present teachings can be applied to plants that utilize biomass as a fuel source. In one embodiment, implementation of the present teachings can be accomplished in a cost-effective manner utilizing low cost hardware designed to remove any large particle ash (LPA) that is present in a flue gas stream prior to SCR treatment. The present teachings also do not affect the current design of boilers and SCRs.

## Claims

1. A system for increasing the active life of an SCR catalyst, the system comprising:

- (i) at least one first flue gas conduit designed to transport flue gas from a combustion zone to an SCR;
- (ii) at least one SCR positioned between the at least one first flue gas conduit and at least one second flue gas conduit, wherein the at least one second flue gas conduit is designed to transport flue gas from the SCR to additional downstream systems or environmental controls;
- (iii) at least one large particle ash screen positioned in the at least one first flue conduit so as to enable the collection of at least about 50 percent of any large particle ash present in the flue gas prior to the entry of the flue gas into the at least one SCR; and
- (iv) at least one rotary valve positioned to be in working communication with the large particle ash screen, wherein the at least one rotary valve is designed to collect any large particle ash captured by the at least one large particle ash screen and supply such large particle ash to the at least one second flue gas conduit.

**EP 2 289 608 B1**

2. The system of claim 1, wherein the at least one large particle ash screen is formed as a mesh screen and/or formed from a plate having one or more openings formed therein.

3. The system of claim 1 or 2, wherein the at least one large particle ash screen is formed from one or more metals, one or more metal alloys, one or more ceramic compositions, or any combination of two or more thereof.

4. The system of any preceding claim, wherein the at least one large particle ash screen positioned in the at least one first flue conduit is designed to enable the collection of at least about 75 percent of any large particle ash present in the flue gas prior to the entry of the flue gas into the at least one SCR.

5. The system of any preceding claim, wherein the at least one large particle ash screen positioned in the at least one first flue conduit is designed to enable the collection of at least 95 percent of any large particle ash present in the flue gas prior to the entry of the flue gas into the at least one SCR.

6. The system of any preceding claim, wherein the large particle ash has a mean particle size of at least about 4 mm to about 6 mm.

7. A system for increasing the active life of an SCR catalyst, the system comprising:

(A) at least one first flue gas conduit designed to transport flue gas from a combustion zone to an SCR, the at least one first flue gas conduit being designed to permit the flue gas to flow at a first flow velocity;

(B) at least one second flue gas conduit that is in operative communication with the at least one first flue gas conduit, wherein the at least one second flue gas conduit is designed to transport flue gas from the at least one first flue gas conduit to an SCR, the at least one second flue gas conduit being designed to permit the flue gas to flow at a second flow velocity, and the second flow velocity is at least 10 percent less than the first flow velocity;

(C) at least one third flue gas conduit designed to transport flue gas from the SCR to additional downstream systems or environmental controls; and

(D) at least one rotary valve positioned to be in working communication with the at least one second flue gas conduit, wherein the at least one rotary valve is designed to collect any large particle ash captured in the at least one second flue gas conduit and supply such large particle ash to the at least one third flue gas conduit,

whereby the combination of the at least one second flue gas conduit and the at least one rotary valve enable the collection of at least about 50 percent of any large particle ash present in the flue gas prior to the entry of the flue gas into the at least one SCR.

8. The system of claim 7, further comprising at least one large particle ash screen located in the at least one second flue gas conduit.

9. The method of claim 8, wherein the at least one large particle ash screen is formed from a mesh screen and/or a plate having one or more openings formed therein.

10. The system of claim 8 or 9, wherein the at least one large particle ash screen is formed from one or more metals, one or more metal alloys, one or more ceramic compositions, or any combination of two or more thereof.

11. The system of any of claims 8 to 10, wherein the large particle ash has a mean particle size of at least about 4 mm to about 6 mm.

12. The system of any of claims 7 to 11, wherein the second flow velocity is at least 20 percent less than the first flow velocity or is at least 30 percent less than the first flow velocity or is at least 40 percent less than the first flow velocity.

13. A method for increasing the active life of an SCR catalyst, the method comprising the steps of:

(a) providing at least one large particle ash collection means designed to collect large particle ash in a flue gas stream upstream of the entry of the flue gas into an SCR; and

(b) collecting the large particle ash in the at least one large particle ash collection means so as to remove at least about 50 percent of the large particle ash from the flue gas stream prior to entry of the flue gas stream into the SCR; and

(c) supplying the collected large particle ash to a point in the flue gas stream downstream of the SCR.

14. The method of claim 13, wherein large particle ash collection means is formed from a combination of at least one large particle ash screen and at least one rotary valve.
15. The method of claim 14, wherein the at least one large particle ash screen is formed as a mesh screen and/or formed from a plate having one or more openings formed therein.
16. The method of claim 13, 14 or 15, wherein large particle ash collection means is formed from a combination of at least one large low velocity flue gas area and at least one rotary valve.

## Patentansprüche

1. System zur Erhöhung der aktiven Lebensdauer eines SCR-Katalysators, wobei das System umfasst:

(i) mindestens eine erste Abgasleitung, die zum Transportieren von Abgas durch eine Verbrennungszone an einen SCR konfiguriert ist;

(ii) mindestens einen SCR, der zwischen der mindestens einen ersten Abgasleitung und mindestens einer zweiten Abgasleitung angeordnet ist, wobei die mindestens eine zweite Abgasleitung zum Transportieren von Abgas aus dem SCR zu zusätzlichen stromabwärtigen Systemen oder Umweltsteuerungen ausgestaltet ist;

(iii) mindestens ein Sieb für große Aschepartikel, das in der mindestens einen ersten Abgasleitung angeordnet ist, um das Sammeln von mindestens etwa 50 Prozent der großen Aschepartikel zu ermöglichen, die in dem Abgas vor dem Eintreten des Abgases in mindestens einen SCR vorhanden sind; und

(iv) mindestens ein Drehschieber, der in Betriebsverbindung mit dem Sieb für große Aschepartikel angeordnet ist, wobei der mindestens eine Drehschieber zum Sammeln von großen Aschepartikeln ausgestaltet ist, die durch das mindestens eine Sieb für große Aschepartikel erfasst werden, und zum Zuführen der großen Aschepartikel zu mindestens einer zweiten Abgasleitung.

2. System nach Anspruch 1, wobei das mindestens eine Sieb für große Aschepartikel als ein Maschensieb ausgebildet ist und/oder aus einer Scheibe ausgebildet ist, die eine oder mehrere Öffnungen darin ausgebildet aufweist.

3. System nach Anspruch 1 oder 2, wobei das mindestens eine Sieb für große Aschepartikel aus einem oder mehreren Metallen, einer oder mehreren Metalllegierungen, einer oder mehreren keramischen Zusammensetzungen oder jeder Kombination aus zwei oder mehr davon ausgebildet ist.

4. System nach einem der vorherigen Ansprüche, wobei das mindestens eine Sieb für große Aschepartikel, das in der mindestens einen ersten Abgasleitung angeordnet ist, ausgebildet ist, um das Sammeln von mindestens etwa 75 Prozent der großen Aschepartikel zu ermöglichen, die in dem Abgas vor dem Eintreten des Abgases in mindestens einen SCR vorliegen.

5. System nach einem der vorherigen Ansprüche, wobei das mindestens eine Sieb für große Aschepartikel, das in der mindestens einen ersten Abgasleitung angeordnet ist, ausgebildet ist, um das Sammeln von mindestens 95 Prozent der großen Aschepartikel zu ermöglichen, die in dem Abgas vor dem Eintreten des Abgases in mindestens einen SCR vorliegen.

6. System nach einem der vorhergehenden Ansprüche, wobei die großen Aschepartikel eine mittlere Partikelgröße von mindestens etwa 4 mm bis etwa 6 mm aufweisen.

7. System zur Erhöhung der aktiven Lebensdauer eines SCR-Katalysators, wobei das System umfasst:

(A) mindestens eine erste Abgasleitung, die zum Transportieren von Abgas aus einer Verbrennungszone zu einem SCR ausgestaltet ist, wobei die mindestens eine erste Abgasleitung ausgestaltet ist, um zuzulassen, dass Abgas bei einer ersten Strömungsgeschwindigkeit fließt;

(B) mindestens eine zweite Abgasleitung, die in Betriebsverbindung mit der mindestens einen ersten Abgasleitung steht, wobei die mindestens eine zweite Abgasleitung zum Transportieren von Abgas aus der mindestens einen ersten Abgasleitung zu einem SCR ausgestaltet ist, wobei die mindestens eine zweite Abgasleitung ausgestaltet ist, um zuzulassen, dass das Abgas bei einer zweiten Strömungsgeschwindigkeit fließt und die zweite Strömungsgeschwindigkeit mindestens 10 Prozent geringer als die erste Strömungsgeschwindigkeit ist;

(C) mindestens eine dritte Abgasleitung, die zum Transportieren des Abgases aus dem SCR zu zusätzlichen

stromabwärtigen Systemen oder Umweltsteuerungen ausgestaltet ist; und

(D) mindestens einen Drehschieber, der in Betriebsverbindung mit der mindestens einen zweiten Abgasleitung steht, wobei der mindestens eine Drehschieber zum Sammeln von großen Aschepartikeln ausgestaltet ist, die in der mindestens einen zweiten Abgasleitung erfasst werden und Zuführen der großen Aschepartikel zu mindestens einer dritten Abgasleitung,

wodurch die Kombination der mindestens einen zweiten Abgasleitung und des mindestens einen Drehschiebers das Sammeln von mindestens etwa 50 Prozent der großen Aschepartikel ermöglicht, die in dem Abgas vor dem Eintreten des Abgases in mindestens einen SCR vorliegen.

8. System nach Anspruch 7, ferner umfassend mindestens ein Sieb für große Aschepartikel, das in der mindestens einen zweiten Abgasleitung angeordnet ist.

9. Verfahren nach Anspruch 8, wobei das mindestens eine Sieb für große Aschepartikel aus einem Maschensieb ausgebildet ist und/oder aus einer Scheibe, die eine oder mehrere Öffnungen darin ausgebildet aufweist.

10. System nach Anspruch 8 oder 9, wobei das mindestens eine Sieb für große Aschepartikel aus einem oder mehreren Metallen, einer oder mehreren Metalllegierungen, einer oder mehreren keramischen Zusammensetzungen oder jeder Kombination aus zwei oder mehr davon ausgebildet ist.

11. System nach einem der Ansprüche 8 bis 10, wobei die großen Aschepartikel eine mittlere Partikelgröße von mindestens etwa 4 mm bis etwa 6 mm aufweisen.

12. System nach einem der Ansprüche 7 bis 11, wobei die zweite Strömungsgeschwindigkeit mindestens 20 Prozent weniger als die erste Strömungsgeschwindigkeit oder mindestens 30 Prozent weniger als die erste Strömungsgeschwindigkeit oder mindestens 40 Prozent weniger als die erste Strömungsgeschwindigkeit ist.

13. Verfahren zur Erhöhung der aktiven Lebensdauer eines SCR-Katalysators, wobei das Verfahren die folgenden Schritte umfasst:

(a) Bereitstellen mindestens eines Sammelmittels für große Aschepartikel, das zum Sammeln von großen Aschepartikeln in einer Abgasströmung stromaufwärts des Eintritts des Abgases in einen SCR ausgestaltet ist; und

(b) Sammeln der großen Aschepartikel in dem mindestens einen Sammelmittel für große Aschepartikel, um mindestens etwa 50 Prozent der großen Aschepartikel aus der Abgasströmung zu entfernen, bevor die Abgasströmung in den SCR eintritt; und

(c) Zuführen der gesammelten großen Aschepartikel zu einer Stelle der Rauchgasströmung stromabwärts des SCR.

14. Verfahren nach Anspruch 13, wobei das Sammelmittel für große Aschepartikel aus einer Kombination von mindestens einem Sieb für große Aschepartikel und mindestens einem Drehschieber ausgebildet ist.

15. Verfahren nach Anspruch 14, wobei das mindestens eine Sieb für große Aschepartikel als ein Maschensieb ausgebildet ist und/oder aus einer Scheibe ausgebildet ist, die eine oder mehrere Öffnungen darin ausgebildet aufweist.

16. Verfahren nach Anspruch 13, 14 oder 15, wobei das Sammelmittel für große Aschepartikel aus einer Kombination von mindestens einem großen Niedergeschwindigkeits-Rauchgasbereich und mindestens einem Drehschieber ausgebildet ist.

## Revendications

1. Système destiné à augmenter la durée de vie d'un catalyseur RCS, le système comprenant :

(i) au moins une première conduite de gaz de carneau conçue pour transporter du gaz de carneau depuis une zone de combustion jusqu'à un RCS ;

(ii) au moins un RCS positionné entre l'au moins une première conduite de gaz de carneau et au moins une deuxième conduite de gaz de carneau, l'au moins une deuxième conduite de gaz de carneau étant conçue

## EP 2 289 608 B1

pour transporter du gaz de carneau depuis le RCS jusqu'à des systèmes ou des contrôles environnementaux supplémentaires en aval ;

(iii) au moins un tamis à cendre en grosses particules positionné dans l'au moins une première conduite de carneau de manière à permettre la collecte d'au moins 50 pour cent environ de toute la cendre en grosses particules présente dans le gaz de carneau avant l'entrée du gaz de carneau dans l'au moins un RCS ; et

(iv) au moins une soupape rotative positionnée pour être en communication fonctionnelle avec le tamis à cendre en grosses particules, l'au moins une soupape rotative étant conçue pour collecter toute la cendre en grosses particules capturée par l'au moins un tamis à cendre en grosses particules et fournir cette cendre en grosses particules à l'au moins une deuxième conduite de gaz de carneau.

2. Système de la revendication 1, dans lequel l'au moins un tamis à cendre en grosses particules est formé comme un tamis à mailles et/ou formé à partir d'une plaque ayant une ou plusieurs ouvertures formées à l'intérieur.

3. Système de la revendication 1 ou 2, dans lequel l'au moins un tamis à cendre en grosses particules est formé à partir d'un ou plusieurs métaux, un ou plusieurs alliages métalliques, une ou plusieurs compositions céramiques, ou toute combinaison d'au moins deux d'entre eux.

4. Système d'une quelconque revendication précédente, dans lequel l'au moins un tamis à cendre en grosses particules positionné dans l'au moins une première conduite de carneau est conçu pour permettre la collecte d'au moins 75 pour cent environ de toute la cendre en grosses particules présente dans le gaz de carneau avant l'entrée du gaz de carneau dans l'au moins un RCS.

5. Système d'une quelconque revendication précédente, dans lequel l'au moins un tamis à cendre en grosses particules positionné dans l'au moins une première conduite de carneau est conçu pour permettre la collecte d'au moins 95 pour cent de toute la cendre en grosses particules présente dans le gaz de carneau avant l'entrée du gaz de carneau dans l'au moins un RCS.

6. Système d'une quelconque revendication précédente, dans lequel la cendre en grosses particules a une taille moyenne de particules d'au moins 4 mm environ à 6 mm environ.

7. Système destiné à augmenter la durée de vie d'un catalyseur RCS, le système comprenant :

(A) au moins une première conduite de gaz de carneau conçue pour transporter du gaz de carneau depuis une zone de combustion jusqu'à un RCS, l'au moins une première conduite de gaz de carneau étant conçue pour permettre au gaz de carneau de circuler à une première vitesse de circulation ;

(B) au moins une deuxième conduite de gaz de carneau qui est en communication fonctionnelle avec l'au moins une première conduite de gaz de carneau, l'au moins une deuxième conduite de gaz de carneau étant conçue pour transporter du gaz de carneau depuis l'au moins une première conduite de gaz de carneau jusqu'à un RCS, l'au moins une deuxième conduite de gaz de carneau étant conçue pour permettre au gaz de carneau de circuler à une deuxième vitesse de circulation, et la deuxième vitesse de circulation étant inférieure d'au moins 10 pour cent à la première vitesse de circulation ;

(C) au moins une troisième conduite de gaz de carneau conçue pour transporter du gaz de carneau depuis le RCS jusqu'à des systèmes ou des contrôles environnementaux supplémentaires en aval ; et

(D) au moins une soupape rotative positionnée pour être en communication fonctionnelle avec l'au moins une deuxième conduite de gaz de carneau, l'au moins une soupape rotative étant conçue pour collecter toute la cendre en grosses particules capturée dans l'au moins une deuxième conduite de gaz de carneau et fournir cette cendre en grosses particules à l'au moins une troisième conduite de gaz de carneau,

la combinaison de l'au moins une deuxième conduite de gaz de carneau et de l'au moins une soupape rotative permettant la collecte d'au moins 50 pour cent environ de toute la cendre en grosses particules présente dans le gaz de carneau avant l'entrée du gaz de carneau dans l'au moins un RCS.

8. Système de la revendication 7, comprenant en outre au moins un tamis à cendre en grosses particules situé dans l'au moins une deuxième conduite de gaz de carneau.

9. Procédé de la revendication 8, dans lequel l'au moins un tamis à cendre en grosses particules est formé à partir d'un tamis à mailles et/ou d'une plaque ayant une ou plusieurs ouvertures formées à l'intérieur.

## EP 2 289 608 B1

10. Système de la revendication 8 ou 9, dans lequel l'au moins un tamis à cendre en grosses particules est formé à partir d'un ou plusieurs métaux, un ou plusieurs alliages métalliques, une ou plusieurs compositions céramiques, ou toute combinaison d'au moins deux d'entre eux.
- 5 11. Système de l'une quelconque des revendications 8 à 10, dans lequel la cendre en grosses particules a une taille moyenne de particules d'au moins 4 mm environ à 6 mm environ.
- 10 12. Système de l'une quelconque des revendications 7 à 11, dans lequel la deuxième vitesse de circulation est inférieure d'au moins 20 pour cent à la première vitesse de circulation ou est inférieure d'au moins 30 pour cent à la première vitesse de circulation ou est inférieure d'au moins 40 pour cent à la première vitesse de circulation.
13. Procédé d'augmentation de la durée de vie d'un catalyseur RCS, le procédé comprenant les étapes consistant à :
- 15 (a) se procurer au moins un moyen de collecte de cendre en grosses particules conçu pour collecter de la cendre en grosses particules dans un courant de gaz de carneau en amont de l'entrée du gaz de carneau dans un RCS ; et
- (b) collecter la cendre en grosses particules dans l'au moins un moyen de collecte de cendre en grosses particules de manière à retirer au moins 50 pour cent environ de la cendre en grosses particules du courant de gaz de carneau avant l'entrée du courant de gaz de carneau dans le RCS ; et
- 20 (c) fournir la cendre en grosses particules collectée à un point dans le courant de gaz de carneau en aval du RCS.
14. Procédé de la revendication 13, dans lequel le moyen de collecte de cendre en grosses particules est formé à partir d'une combinaison d'au moins un tamis à cendre en grosses particules et d'au moins une soupape rotative.
- 25 15. Procédé de la revendication 14, dans lequel l'au moins un tamis à cendre en grosses particules est formé comme un tamis à mailles et/ou formé à partir d'une plaque ayant une ou plusieurs ouvertures formées à l'intérieur.
- 30 16. Procédé de la revendication 13, 14 ou 15, dans lequel le moyen de collecte de cendre en grosses particules est formé à partir d'une combinaison d'au moins une large zone de gaz de carneau à faible vitesse et d'au moins une soupape rotative.

35

40

45

50

55

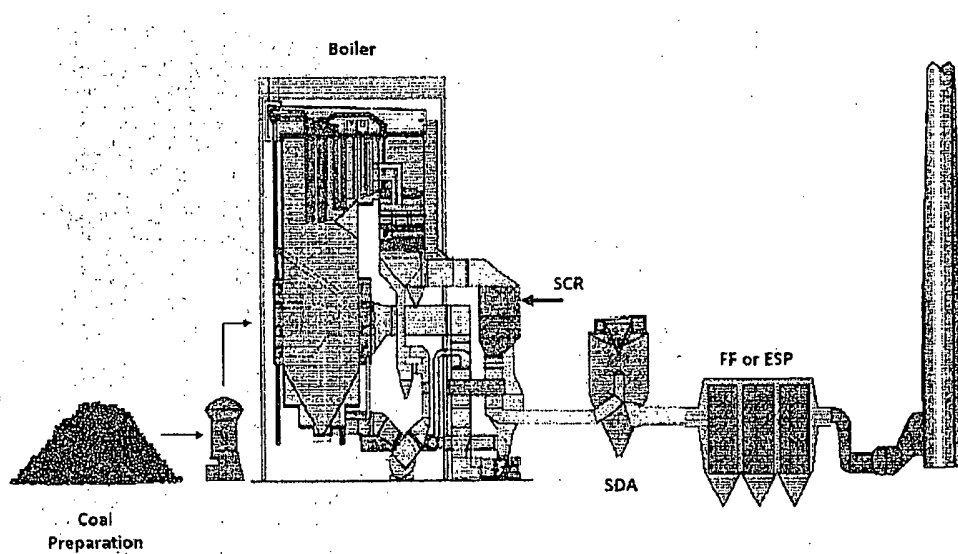

FIG. 1

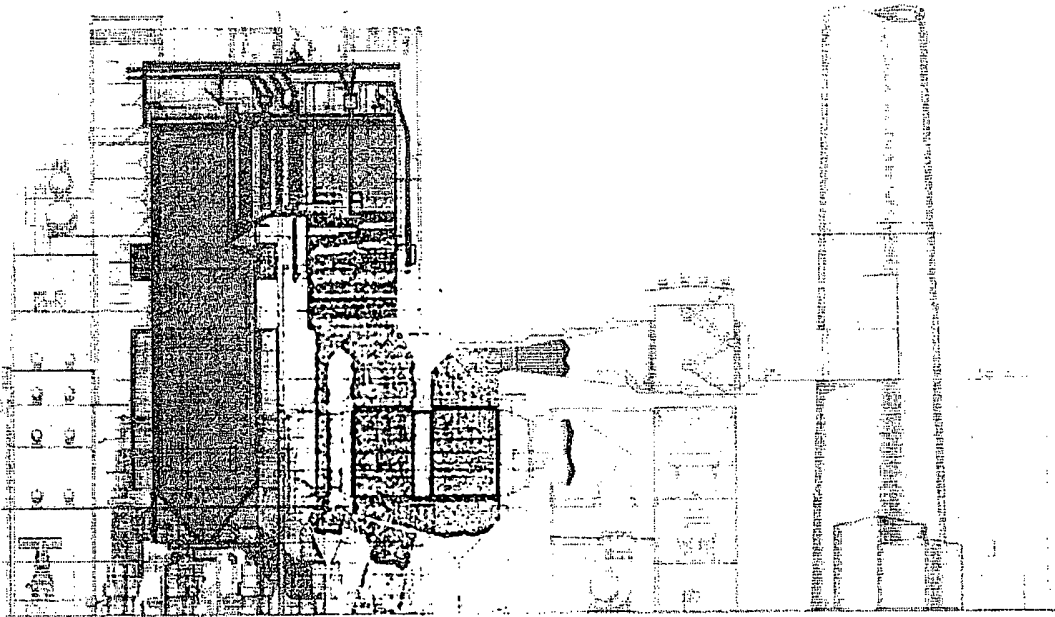

FIG. 2

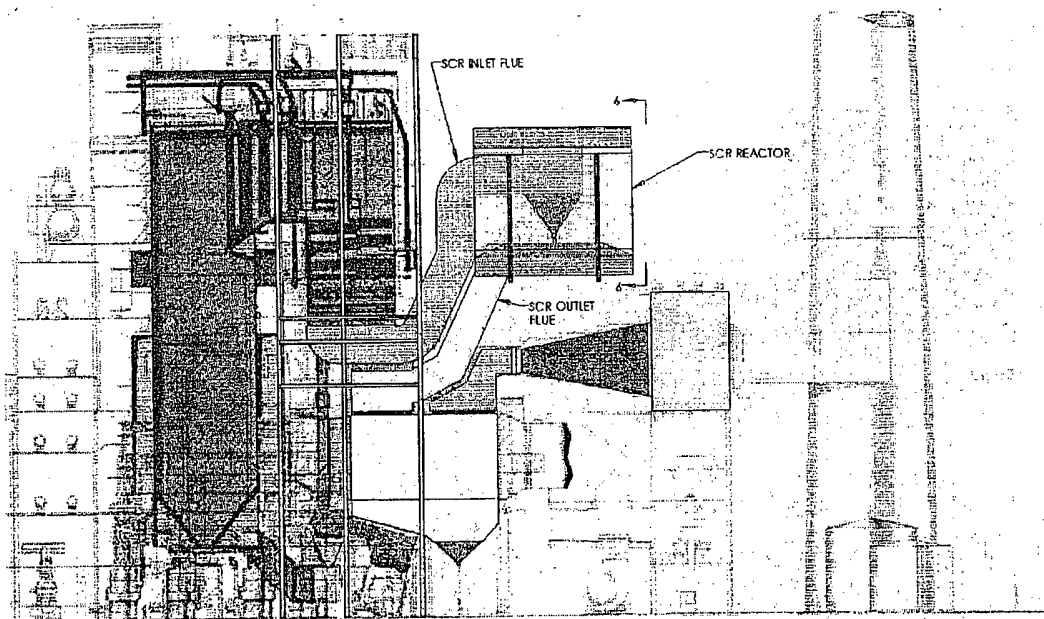

FIG. 3

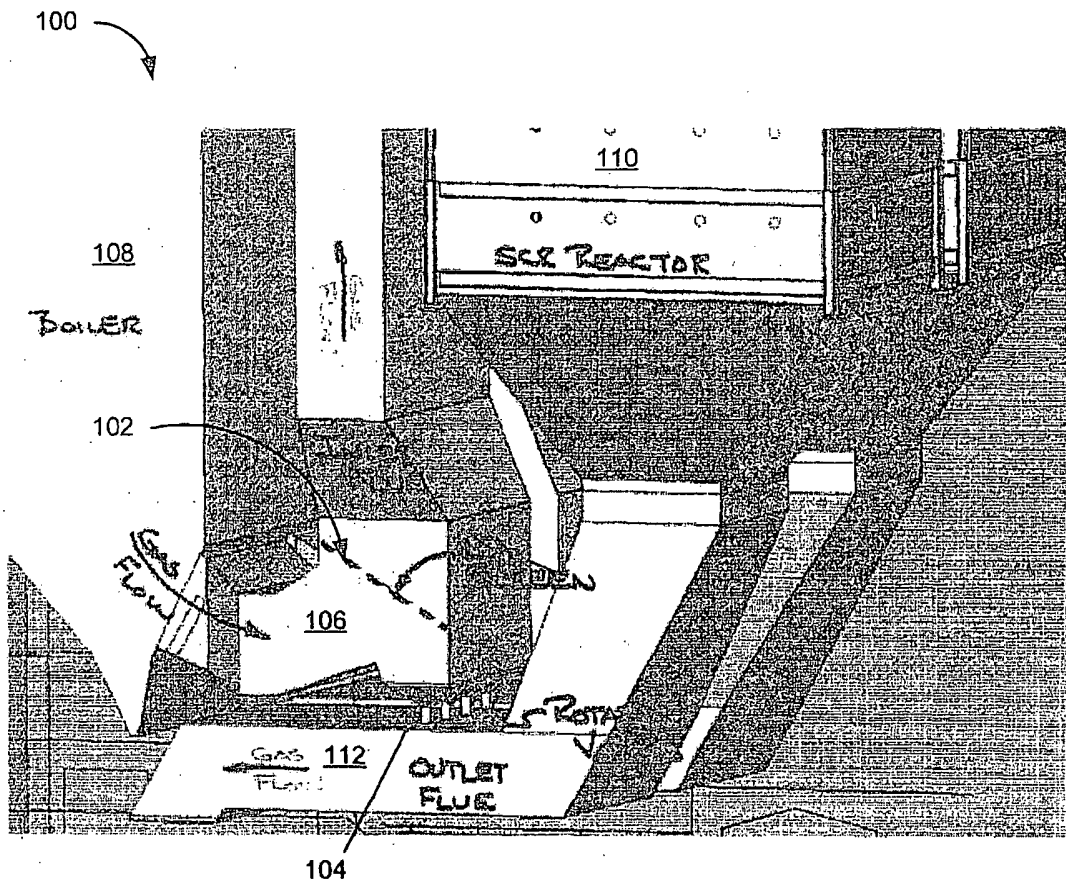

FIG. 4

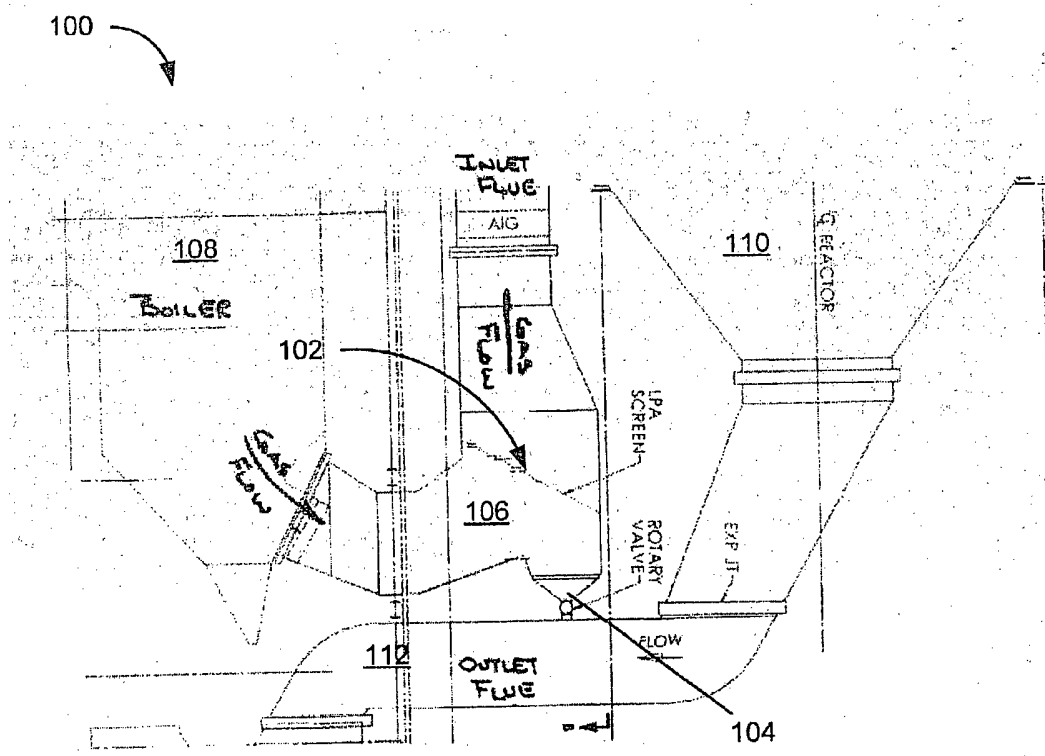

FIG. 5

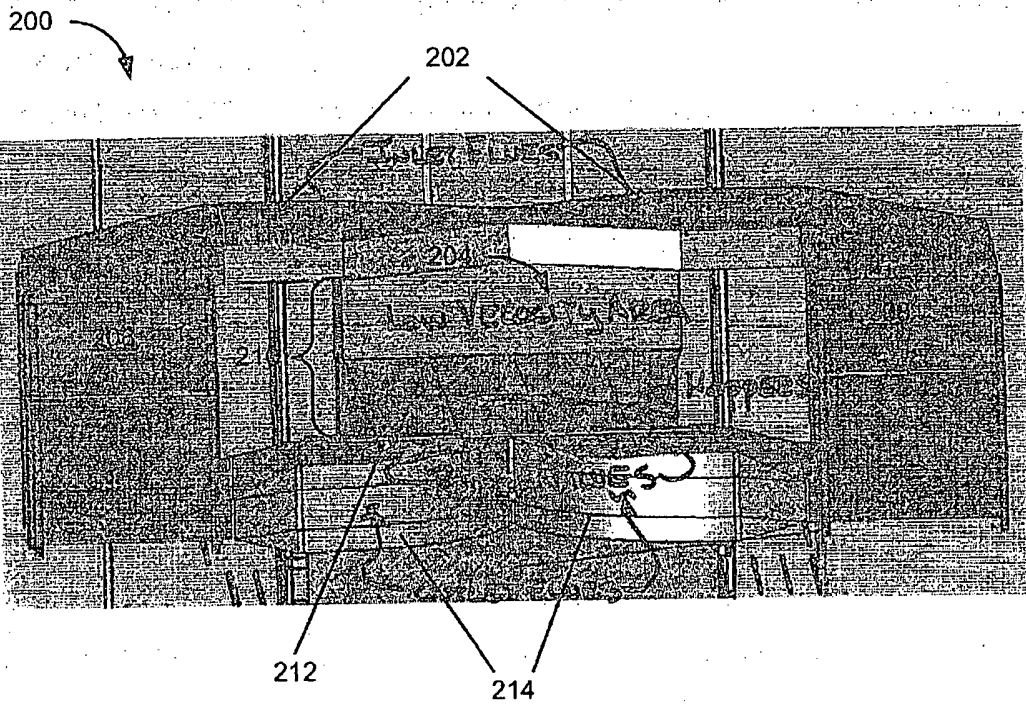

FIG. 6

**REFERENCES CITED IN THE DESCRIPTION**

*This list of references cited by the applicant is for the reader's convenience only. It does not form part of the European patent document. Even though great care has been taken in compiling the references, errors or omissions cannot be excluded and the EPO disclaims all liability in this regard.*

**Patent documents cited in the description**

- US 5540897 A [0007]
- US 5567394 A [0007]
- US 5585081 A, Chu [0007]
- US 20050061261 A1 [0013]
- WO 2005114053 A [0014]

**Non-patent literature cited in the description**

- Nitrogen Oxides Control. Steam: its generation and use. The Babcock & Wilcox Company, 2005 [0004]

## Szabadalmi igénypontok

1. Rendszer SCR katalizátor aktív élettartamának növelésére, amely rendszer tartalmaz:

i) legalább egy első füstgáz csővezeték, amely úgy van kialakítva, hogy a füstgázt az égéstérből egy SCR-hez továbbítja;

ii) legalább egy SCR-t, amely a legalább egy első füstgáz csővezeték és legalább egy második füstgáz csővezeték között van elhelyezve, ahol a legalább egy második füstgáz csővezeték úgy van kialakítva, hogy a füstgázt az SCR-ből az utána következő további rendszerekhez vagy klíma berendezésekhez vezeti;

iii) legalább egy nagy részecskeméretű hamu szűrőt, amely a legalább egy első füstgáz csővezetékben van elhelyezve, hogy a füstgázban jelenlévő nagy részecskeméretű hamu legalább 50 %-át képes összegyűjteni a füstgáznak a legalább egy SCR-be történő belépése előtt; és

iv) legalább egy rotációs szelepet, amely úgy van elhelyezve, hogy az a nagy részecskeméretű hamu szíttával működési kapcsolatban van, ahol a legalább egy rotációs szelep úgy van kialakítva, hogy az összegyűjti a legalább egy nagy részecskeméretű hamu szűrő által kiszűrt nagy részecskeméretű hamut, és az ilyen nagy részecskeméretű hamut a legalább egy második füstgáz csővezetékbe táplálja.

2. Az 1. igénypont szerinti rendszer, ahol a legalább egy nagy részecskeméretű hamu szűrő szitaszövetből és/vagy egy vagy több nyílással ellátott lemezből van kialakítva.

3. Az 1. vagy 2. igénypont szerinti rendszer, ahol a legalább egy nagy részecskeméretű hamu szűrő egy vagy több fémből, egy vagy több fémötvözetből, egy vagy több kerámia kompozícióból vagy ezek közül kettő vagy több kombinációjából van kialakítva.

4. Az előző igénypontok bármelyike szerinti rendszer, ahol a legalább egy első füstgáz csővezetékben elhelyezett legalább egy nagy részecskeméretű hamu szűrő úgy van kialakítva, hogy a füstgázban jelenlévő nagy részecskeméretű hamu legalább körülbelül 75%-át képes összegyűjteni a füstgáznak a legalább egy SCR-be történő belépése előtt.

5. Az előző igénypontok bármelyike szerinti rendszer, ahol a legalább egy első füstgáz csővezetékben elhelyezett legalább egy nagy részecskeméretű hamu szűrő úgy van kialakítva, hogy a füstgázban jelenlévő nagy részecskeméretű hamu legalább 95%-át képes összegyűjteni a füstgáznak a legalább egy SCR-be történő belépése előtt.

6. Az előző igénypontok bármelyike szerinti rendszer, ahol a nagy részecskeméretű hamu közepes részecskemérete legalább körülbelül 4-6 mm.

7. Rendszer SCR katalizátor aktív élettartamának növelésére, amely rendszer tartalmaz:

A) legalább egy első füstgáz csővezeték, amely úgy van kialakítva, hogy a füstgázt az égéstérből egy SCR-hez vezeti, amely legalább egy első füstgáz csővezeték úgy van kialakítva, hogy lehetővé teszi a füstgáznak egy első áramlási sebességgel való áramoltatását;

B) legalább egy második füstgáz csővezeték, amely működési kapcsolatban van a legalább egy első füstgáz csővezetékkel, amely legalább egy második füstgáz csővezeték úgy van kialakítva, hogy a füstgázt a legalább egy első füstgáz csővezetékől egy SCR-be vezeti, ahol a legalább egy második füstgáz csővezeték úgy van kialakítva, hogy lehetővé teszi a füstgáznak egy második áramlási sebességgel történő áramoltatását, és a második áramlási sebesség legalább 10%-kal kisebb, mint az első áramlási sebesség;

C) legalább egy harmadik füstgáz csővezeték, amely úgy van kialakítva, hogy a füstgázt az SCR-ből az utána következő további rendszerekhez vagy klíma berendezésekhez vezeti; és

D) legalább egy rotációs szelepet, amely úgy van elhelyezve, hogy működési kapcsolatban van a legalább egy második füstgáz csővezetékkel, ahol a legalább egy rotációs szelep úgy van kialakítva, hogy az összegyűjti a legalább egy második füstgáz csővezetékben kiszűrt nagy részecskeméretű hamut, és az ilyen nagy részecskeméretű hamut legalább egy harmadik füstgáz csővezetékbe vezeti,

ahol a legalább egy második füstgáz csővezeték és a legalább egy rotációs szelep kombinációja képes összegyűjteni a füstgázban jelenlévő nagy részecskeméretű hamu legalább körülbelül 50%-át a füstgáznak a legalább egy SCR-be történő belépése előtt.

8. A 7. igénypont szerinti rendszer, amely tartalmaz továbbá legalább egy nagy részecskeméretű hamu szűrőt a legalább egy második füstgáz csővezetékben elhelyezve.

9. A 8. igénypont szerinti eljárás, ahol a legalább egy nagy részecskeméretű hamu szűrő szítaszövetből és/vagy egy vagy több nyílással ellátott lemezből van kialakítva.

10. A 8. vagy 9. igénypont szerinti rendszer, ahol a legalább egy nagy részecskeméretű hamu szűrő egy vagy több fémből, egy vagy több fémötvözetből, egy vagy több kerámia kompozícióból vagy ezek közül kettő vagy több kombinációjából van kialakítva.

11. A 8-10. igénypontok bármelyike szerinti rendszer, ahol a nagy részecskeméretű hamu közepes részecskemérete legalább körülbelül 4-6 mm.

12. A 7-11. igénypontok bármelyike szerinti rendszer, ahol a második áramlási sebesség legalább 20%-kal kisebb mint az első áramlási sebesség, vagy legalább 30%-kal kisebb mint az első áramlási sebesség, vagy legalább 40%-kal kisebb mint az első áramlási sebesség.

13. Eljárás SCR katalizátor aktív élettartamának növelésére, amely eljárás tartalmazza a következő lépéseket:

a) előállítunk legalább egy nagy részecskeméretű hamu összegyűjtő eszközt, amely úgy van kialakítva, hogy egy füstgáz áramból összegyűjti a nagy részecskeméretű hamut a füstgáz áramnak egy SCR-be történő belépése előtt; és

b) a legalább egy nagy részecskeméretű hamu összegyűjtő eszközben összegyűjtjük a nagy részecskeméretű hamut, ezzel eltávolítva a füstgáz áramból a nagy részecskeméretű hamu legalább körülbelül 50%-át a füstgáz áramnak az SCR-be történő belépése előtt; és

c) az összegyűjtött nagy részecskeméretű hamut az SCR után egy ponton betápláljuk a füstgázáramba.

14. A 13. igénypont szerinti eljárás, ahol a nagy részecskeméretű hamu összegyűjtő eszközt legalább egy nagy részecskeméretű hamu szűrő és legalább egy rotációs szelep kombinációjából alakítjuk ki.

15. A 14. igénypont szerinti eljárás, ahol a legalább egy nagy részecskeméretű hamu szűrőt szitaszövetből és/vagy egy vagy több nyílással ellátott lemezből alakítjuk ki.

16. A 13., 14. vagy 15. igénypont szerinti eljárás, ahol a nagy részecskeméretű hamu összegyűjtő eszközt a kisebbességű füstgáz legalább egy nagy területének és legalább egy rotációs szeleppel a kombinációjából alakítjuk ki.