

Oct. 15, 1935.

H. S. COVELL

2,017,306

REGISTER

Filed Oct. 28, 1933

2 Sheets-Sheet 1

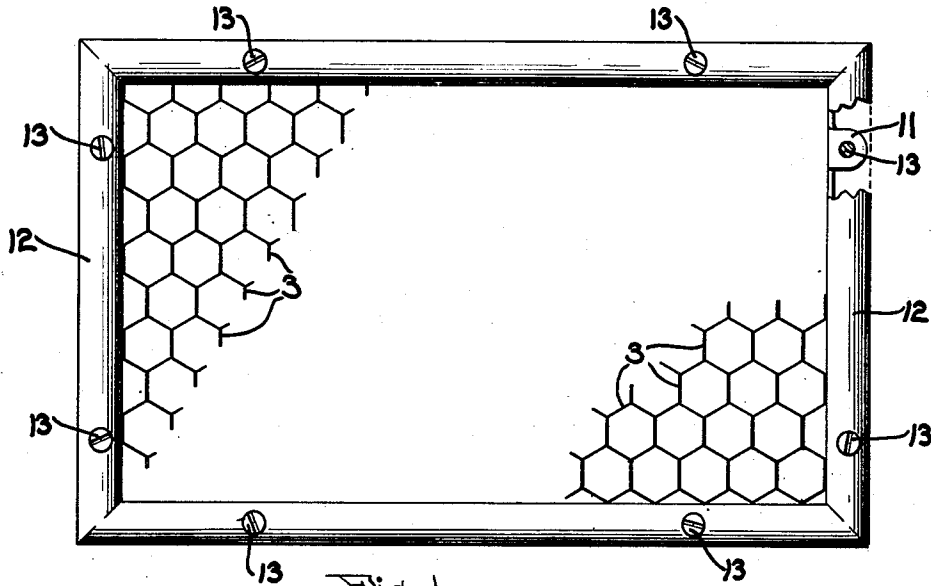

Fig. 1.

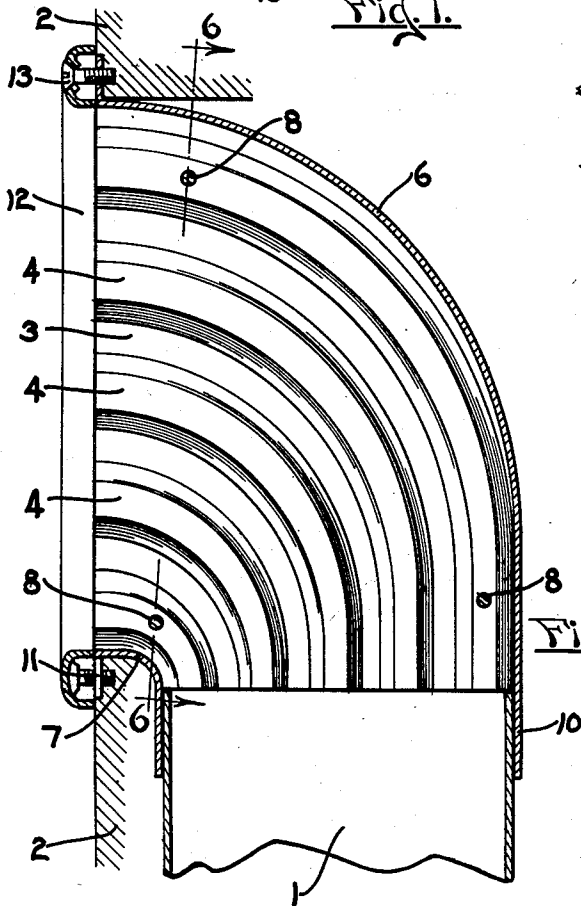

Fig. 2.

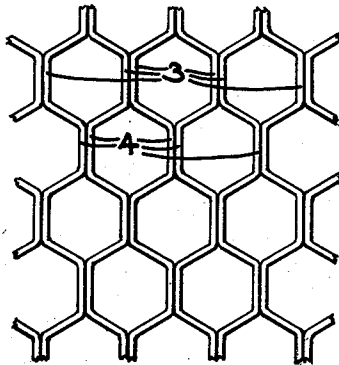

Fig. 3.

Inventor  
Harold S. Covell  
By Lawrence and  
Van Antwerp  
Attorneys

Oct. 15, 1935.

H. S. COVELL

2,017,306

REGISTER

Filed Oct. 28, 1933

2 Sheets-Sheet 2

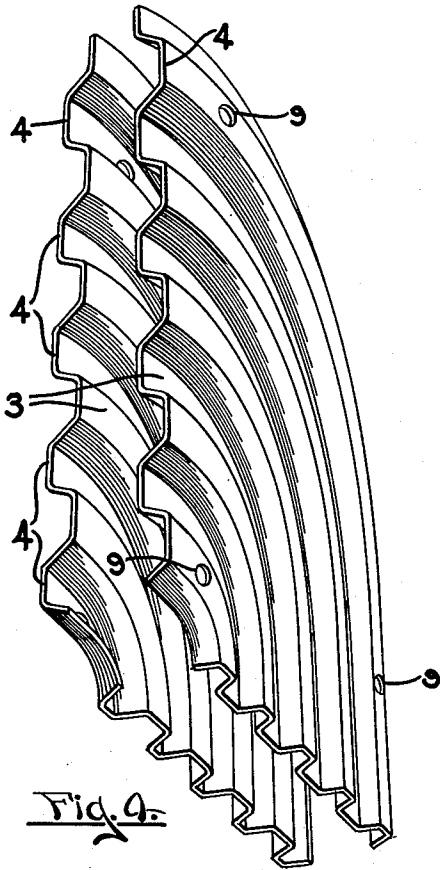

Fig. 4.

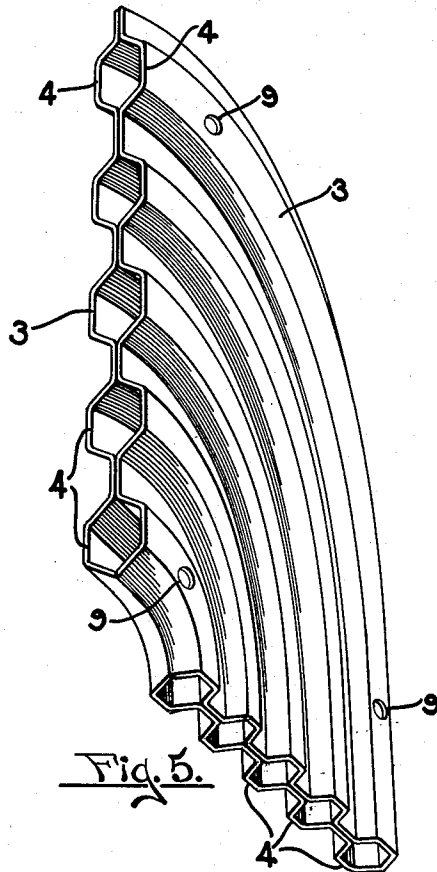

Fig. 5.

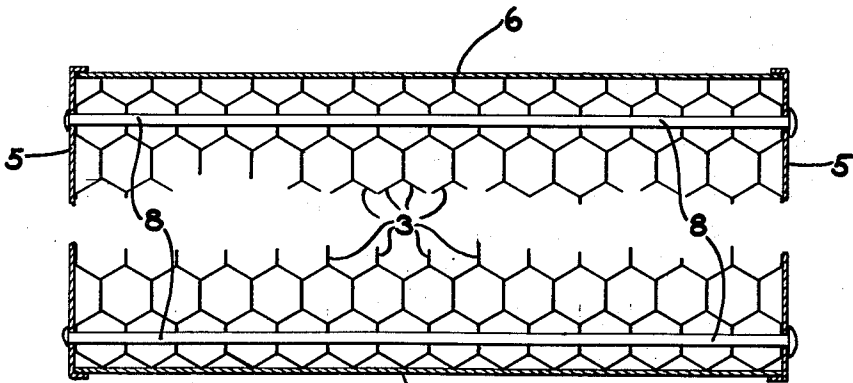

Fig. 6.

Inventor  
Harold S. Covell  
By Livance  
Van Antwerp  
Attorneys

# UNITED STATES PATENT OFFICE

2,017,306

REGISTER

Harold S. Covell, Holland, Mich., assignor to  
Hart & Cooley Manufacturing Company, Hol-  
land, Mich., a corporation of Michigan

Application October 28, 1933, Serial No. 695,590

3 Claims. (Cl. 98—114)

This invention relates to a furnace flue stack head and register. It is especially adapted to be used in connection with a furnace having forced air circulation and is to be located at the end of the flue or stack where the warm air enters the room.

In the big majority of furnace flues used to conduct warm air from the furnace into the room to be heated the flue or stack extends upward through the wall of the building and then turns sharply to direct the air outwardly through the side of the wall into the room. An ordinary flue construction this bend in the stack or stack head causes a turbulence of air passing through it. The air tends to follow a straight line in its course and at the point where the stack turns it does not readily follow the turn but sets up eddy currents which interfere with the flow of air.

The principal object of this invention is to provide a device which will guide the whole body of the air current around a bend in the stack smoothly and without eddy currents or turbulence so that it may continue its flow beyond the bend or be injected into the room in full volume distributed over the entire area of the conduit. A further object of the invention is to provide a structure to accomplish the result which is simple and comparatively cheap to manufacture. A further object of the invention is to provide a structure having an outlet end which may be exposed in the wall of a room with a pleasing appearance and which will eliminate the use of the ordinary radiator grille.

The invention provides various new and useful features of construction and arrangement as hereinafter more fully described and particularly pointed out in the claims, reference being had to the accompanying drawings, in which,

Fig. 1 is a front view of the device as applied to the wall of a room and surrounded by a frame, a portion of the frame being broken away.

Fig. 2 is a vertical section of the device located in a wall and attached to the end of a flue.

Fig. 3 is a fragmentary enlarged view of the front of the device indicating the honeycomb structure.

Fig. 4 is a perspective view of two of the plates, of which the structure is formed, in spaced apart relation.

Fig. 5 shows the two plates of Fig. 4 moved into contact and in assembled relationship, and

Fig. 6 is a cross section of the device on the line 6—6 of Fig. 2 with the central portion removed.

Like reference numbers refer to like parts in all of the figures.

1 represents an ordinary furnace flue or wall stack which arises vertically in the wall 2 and from which the current of warm air from the furnace is to be turned at right angles and directed through the wall into the room to be heated.

The device, which comprises the stackhead and grille structure, is formed of a plurality of plates which are stamped to provide a plurality of grooves alternately arranged on opposite sides of the plate so that when the plurality of plates are placed side by side in assembled relation the grooves of the respective plates will form passageways through the structure. The plates and the grooves in them are curved to constitute segments of a circle so that an air current entering the passages will be turned to an angle in emerging therefrom.

The drawings illustrate the plates and grooves therein as being narrower at the inlet side than at the outlet side although if preferred the grooves may be of the same width throughout their length. The plates 3 are of two varieties, each oppositely stamped than the other or in other words are made right and left-hand. The arc shaped grooves 4 stamped into them may be of any desired cross sectional shape, those illustrated constitute a half of a hexagon, and the space on one side of the plate between grooves on the opposite side of the plate also forms grooves on the first side of the plate similar in shape to those on the opposite side.

When the structure is assembled the right and left-hand plates are alternately arranged and are in engagement with each other to form a large number of arc shaped hexagonal passages throughout the whole body of the device. End members 5 and the top and bottom members 6 and 7 of sheet metal surround the structure and the whole assembly is preferably held together by bolts or riveted rods 8 which pass through alined holes 9 provided in the various parts. The cover members 5, 6 and 7 extend beyond the body portion as at 10 at the entrance end and serve as a jacket to receive the end of the flue 1 and suitable means, such as ears 11, are provided by which the device can be attached to the wall in which it is located.

The outlet end of the device is finished smooth and can be polished or otherwise decorated and because of its structure it presents an attractive appearance and eliminates the necessity of providing an extra grille which is commonly used on a radiator. The honey-comb structure is of attractive design and also because of the plurality

of passages, which are curved, vision into the furnace flue is prevented, this having been the principal object of the conventional grille. It is preferable to provide a simple frame 12 to surround the edge of the device and to cover the joint between it and the wall and also the attaching ears 11. The frame 12 may be attached by the same screws 13 which pass through the ears 11 to hold the device in place.

One use of the device is in heating a room where the warm air enters through an inside wall in which case the stackhead of this invention is located at a height above that of a person. A forced air circulation is provided and this stackhead acts to direct the air current horizontally into the room in a full stream without turbulence and with sufficient force so that the warm air is carried clear across the room to the opposite outside wall where the most heat is required. In this use the passages through the structure are of uniform size throughout their length and the flow of the air current is not appreciably reduced in making the turn in the structure.

Another use of the invention is in introducing the warm air into the room at a low level where a strong air current would be objectionable. In this case the passages through the device are considerably larger at the outlet end than at the inlet end. In this form of structure the air may enter the device at a rapid rate but because of the enlargement of the passages the current is expanded and the rate of flow is correspondingly reduced at its outlet side.

This device is simple to manufacture since its body structure is composed of duplicate parts which may be easily stamped from relatively thin sheet metal and quickly assembled. The length of the device may be made any desired dimension by assembling more or less of the plates in the structure and without change of dies. Also, the cost of the grille used with ordinary radiators is eliminated.

This device functions to both change the course of the air current and to keep its flow evenly distributed throughout the cross sectional area thereof when its course is changed and also may be constructed to enlarge the volume and thereby reduce the velocity of the current which is sometimes desirable as heretofore mentioned.

The invention is defined in the appended claims and is to be considered comprehensive of all forms of structure coming within their scope.

I claim:

1. A device of the class described comprising a body structure formed of a plurality of plates arranged adjacent each other and having elongated grooves provided in the respective plates whereby a plurality of elongated passages are provided through the structure, said grooves and said passages being of increasing size from the inlet side to the outlet side, means for attaching a furnace flue to the inlet side of the said body in communication with the passages therethrough and means for mounting said device in a wall in a manner to expose its outlet side through the wall.

2. The elements in combination defined in claim 1 in which said grooves and passages are formed in arcs of circles.

3. A device of the class described comprising a body structure formed of a plurality of single thickness plates arranged adjacent each other and having elongated grooves provided in the respective plates whereby a plurality of elongated passages are provided through the structure, said grooves and said passages being of increasing size from one end to the other, means for attaching a furnace flue to the inlet side of the said body in communication with the passages therethrough and means for mounting said device in a wall in a manner to expose its outlet side through the wall.

HAROLD S. COVELL.