

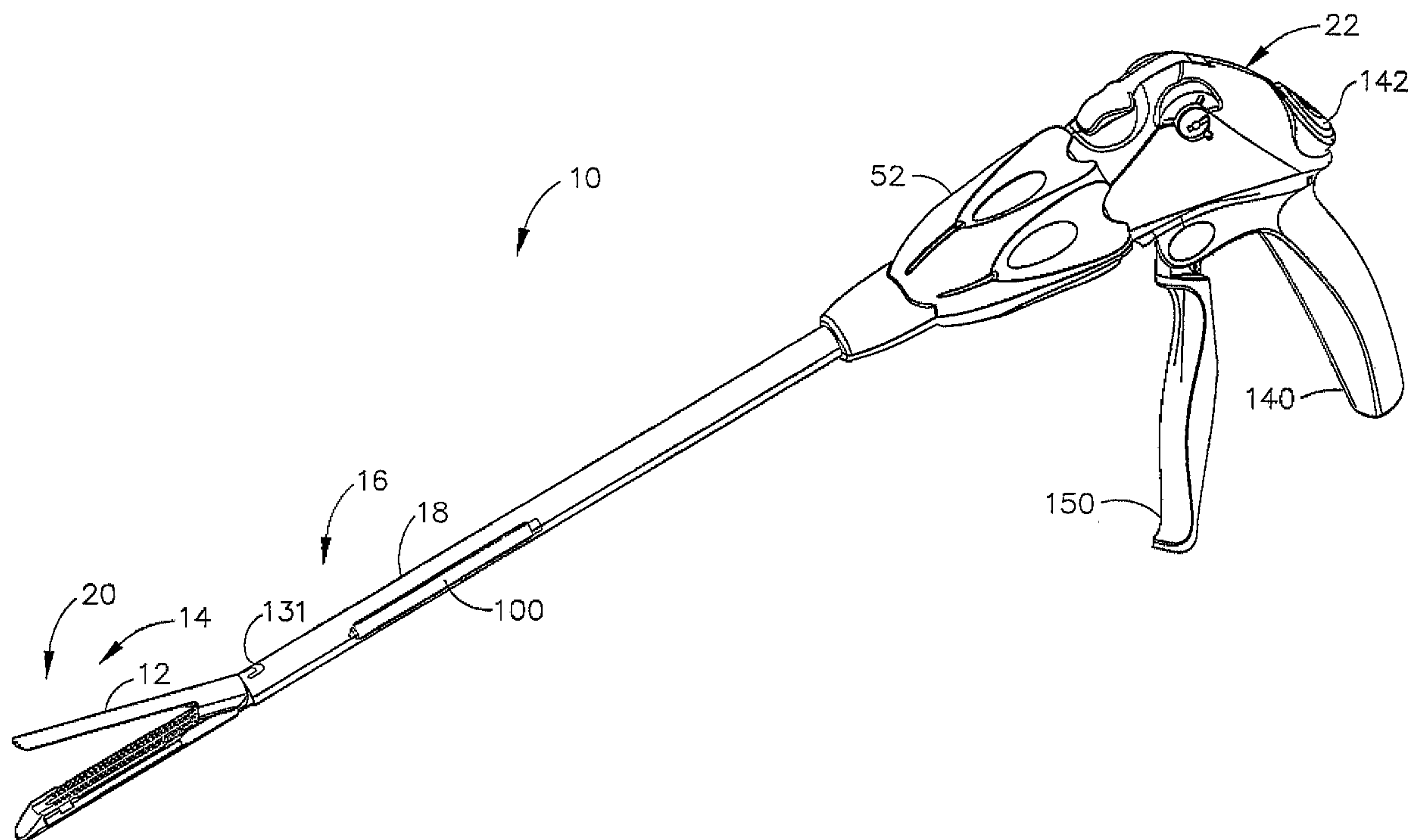

(86) **Date de dépôt PCT/PCT Filing Date:** 2011/01/13  
 (87) **Date publication PCT/PCT Publication Date:** 2011/08/04  
 (45) **Date de délivrance/Issue Date:** 2018/02/13  
 (85) **Entrée phase nationale/National Entry:** 2012/06/28  
 (86) **N° demande PCT/PCT Application No.:** US 2011/021051  
 (87) **N° publication PCT/PCT Publication No.:** 2011/094066  
 (30) **Priorité/Priority:** 2010/01/29 (US12/696,397)

(51) **Cl.Int./Int.Cl. A61B 17/068** (2006.01),  
**A61B 17/00** (2006.01), **A61B 17/072** (2006.01)  
 (72) **Inventeurs/Inventors:**  
SHELTON, FREDERICK E., IV, US;  
HUEIL, JOSEPH C., US;  
MORGAN, JEROME R., US;  
FUGIKAWA, LESLIE M., US  
 (73) **Propriétaire/Owner:**  
ETHICON ENDO-SURGERY, INC., US  
 (74) **Agent:** NORTON ROSE FULBRIGHT CANADA  
LLP/S.E.N.C.R.L., S.R.L.

(54) **Titre : INSTRUMENT D'AGRAFAGE CHIRURGICAL AYANT UN DISTRIBUTEUR DE SUBSTANCE MEDICALE**  
 (54) **Title: SURGICAL STAPLING INSTRUMENT HAVING A MEDICAL SUBSTANCE DISPENSER**



(57) **Abrégé/Abstract:**

In various embodiments, an assembly of a surgical instrument is disclosed. The assembly includes a housing, a cutting member relatively movable with respect to the housing, and an agent cartridge connected to the housing. The agent cartridge houses a medical agent. The assembly is configured to deliver the medical agent proximate a cutting surface of the cutting member.

## (12) INTERNATIONAL APPLICATION PUBLISHED UNDER THE PATENT COOPERATION TREATY (PCT)

(19) World Intellectual Property Organization  
International Bureau(43) International Publication Date  
4 August 2011 (04.08.2011)(10) International Publication Number  
**WO 2011/094066 A1**

## (51) International Patent Classification:

A61B 17/068 (2006.01) A61B 17/00 (2006.01)  
A61B 17/072 (2006.01)

## (21) International Application Number:

PCT/US2011/021051

## (22) International Filing Date:

13 January 2011 (13.01.2011)

## (25) Filing Language:

English

## (26) Publication Language:

English

## (30) Priority Data:

12/696,397 29 January 2010 (29.01.2010) US

(71) Applicant (for all designated States except US):  
**ETHICON ENDO-SURGERY, INC.** [US/US]; 4545  
Creek Road, Cincinnati, OH 45242 (US).

## (72) Inventors; and

(75) Inventors/Applicants (for US only): **SHELTON, Fred-  
erick, E.** [US/US]; 245 East Main Street, Hillsboro, OH  
45133 (US). **HUEIL, Joseph, C.** [US/US]; 11611  
Thistlehill Drive, Loveland, OH 45140 (US). **MORGAN,  
Jerome, R.** [US/US]; 3275 S. Whitetree Circle, Cincin-  
nati, OH 45236 (US). **FUGIKAWA, Leslie, M.**  
[US/US]; 1000 Ligorioavenue, Cincinnati, OH 45218  
(US).(74) Agents: **GARNER, Dean, L.** et al.; Johnson & Johnson,  
One Johnson & Johnson Plaza, New Brunswick, NJ  
08933 (US).(81) Designated States (unless otherwise indicated, for every  
kind of national protection available): AE, AG, AL, AM,  
AO, AT, AU, AZ, BA, BB, BG, BH, BR, BW, BY, BZ,  
CA, CH, CL, CN, CO, CR, CU, CZ, DE, DK, DM, DO,  
DZ, EC, EE, EG, ES, FI, GB, GD, GE, GH, GM, GT,  
HN, HR, HU, ID, IL, IN, IS, JP, KE, KG, KM, KN, KP,  
KR, KZ, LA, LC, LK, LR, LS, LT, LU, LY, MA, MD,  
ME, MG, MK, MN, MW, MX, MY, MZ, NA, NG, NI,  
NO, NZ, OM, PE, PG, PH, PL, PT, RO, RS, RU, SC, SD,  
SE, SG, SK, SL, SM, ST, SV, SY, TH, TJ, TM, TN, TR,  
TT, TZ, UA, UG, US, UZ, VC, VN, ZA, ZM, ZW.(84) Designated States (unless otherwise indicated, for every  
kind of regional protection available): ARIPO (BW, GH,  
GM, KE, LR, LS, MW, MZ, NA, SD, SL, SZ, TZ, UG,  
ZM, ZW), Eurasian (AM, AZ, BY, KG, KZ, MD, RU, TJ,  
TM), European (AL, AT, BE, BG, CH, CY, CZ, DE, DK,  
EE, ES, FI, FR, GB, GR, HR, HU, IE, IS, IT, LT, LU,  
LV, MC, MK, MT, NL, NO, PL, PT, RO, RS, SE, SI, SK,  
SM, TR), OAPI (BF, BJ, CF, CG, CI, CM, GA, GN, GQ,  
GW, ML, MR, NE, SN, TD, TG).

## Declarations under Rule 4.17:

- as to the identity of the inventor (Rule 4.17(i))
- as to applicant's entitlement to apply for and be granted  
a patent (Rule 4.17(ii))
- as to the applicant's entitlement to claim the priority of  
the earlier application (Rule 4.17(iii))

## Published:

- with international search report (Art. 21(3))

[Continued on next page]

(54) Title: SURGICAL STAPLING INSTRUMENT HAVING A MEDICAL SUBSTANCE DISPENSER

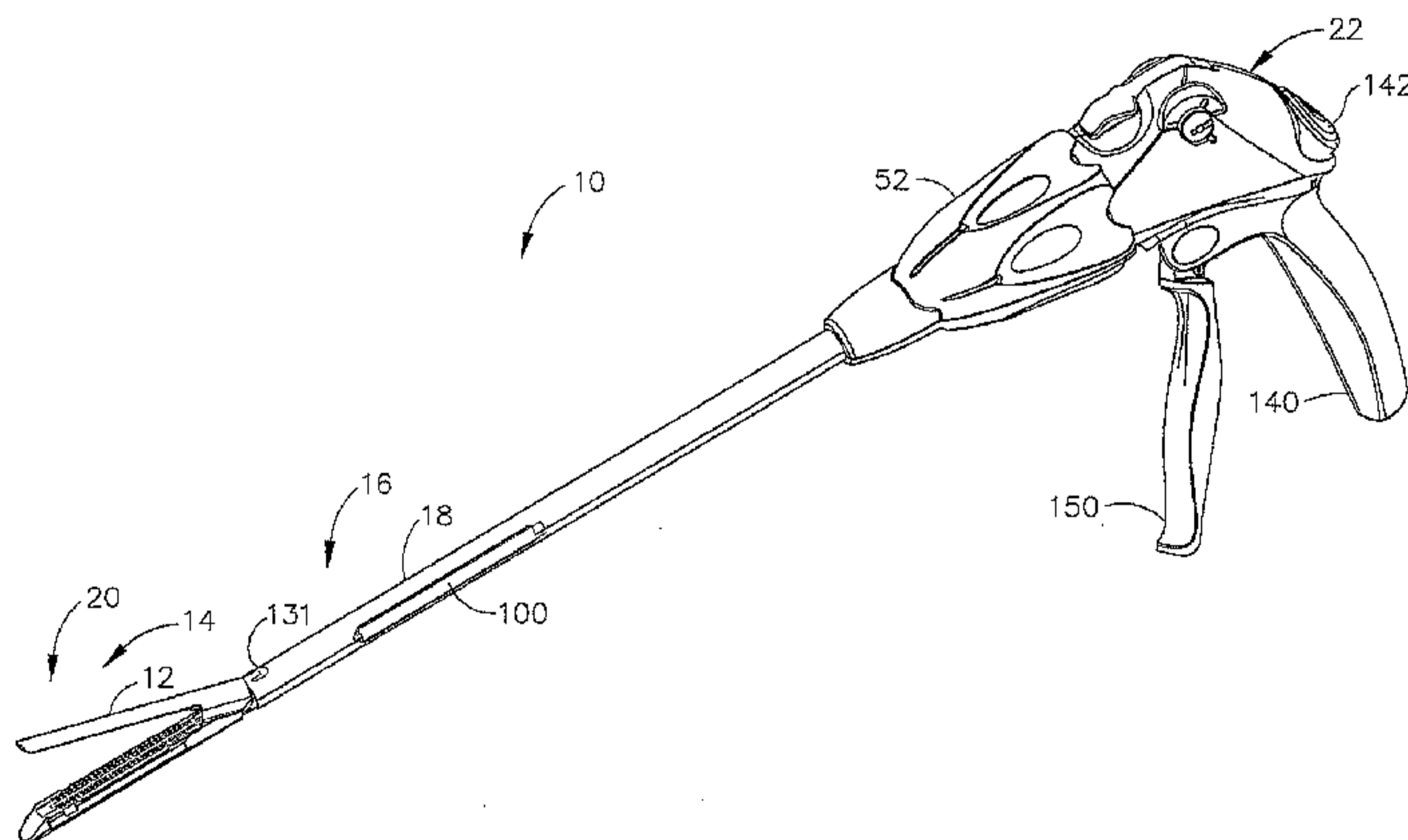

FIG. 1

(57) Abstract: In various embodiments, an assembly of a surgical instrument is disclosed. The assembly includes a housing, a cutting member relatively movable with respect to the housing, and an agent cartridge connected to the housing. The agent cartridge houses a medical agent. The assembly is configured to deliver the medical agent proximate a cutting surface of the cutting member.

**WO 2011/094066 A1** 

---

- *before the expiration of the time limit for amending the claims and to be republished in the event of receipt of amendments (Rule 48.2(h))*

TITLE

**SURGICAL STAPLING INSTRUMENT  
HAVING A MEDICAL SUBSTANCE DISPENSER**

## BACKGROUND

[0002] The present application relates in general to surgical stapler instruments that are capable of applying lines of staples to tissue while cutting the tissue between those staple lines and, more particularly, to improvements relating to stapler instruments and improvements in processes for forming various components of such stapler instruments. This application also discloses devices that are related, generally and in various embodiments, to a disposable loading unit configured for connection to a reusable surgical instrument, and to surgical instruments that include a disposable loading unit.

[0003] Surgical instruments that are utilized to concurrently make longitudinal incisions in tissue and apply lines of staples on opposing sides of the incisions are known in the art. The tissue may include, for example, human tissue, animal tissue, membranes, or other organic substances. Such surgical instruments commonly include a pair of opposing jaw members that cooperate to grasp or clamp the tissue therebetween and a cutting surface that makes the incision. When employed in endoscopic or laparoscopic applications, the opposing jaw members are capable of passing through a cannula passageway. One of the jaw members typically supports a staple cartridge having at least two laterally spaced rows of staples and pushers aligned with the staples. The other jaw member is movable between an open position and a closed position, and defines an anvil having staple-forming pockets correspondingly aligned with the rows of staples in the staple cartridge. Such instruments may also include a wedge that, when driven, sequentially contacts the pushers to effect the firing of the staples toward the anvil and through the tissue.

[0004] An example of a surgical stapler suitable for endoscopic applications, described in U.S. Pat. No. 5,465,895, advantageously provides distinct closing and firing actions. Thereby, a

clinician is able to close the jaw members upon tissue to position the tissue prior to firing. Once the clinician has determined that the jaw members are properly gripping tissue, the clinician can then fire the surgical stapler, thereby severing and stapling the tissue. The simultaneous severing and stapling avoids complications that may arise when performing such actions sequentially with different surgical tools that respectively only sever or staple.

**[0005]** However, the trauma caused to the tissue with such actions can be significant. In general, the delivery of sufficient amounts of medical agents to the site of the traumatized tissue promotes the proper sealing of the incision, reduces the possibility of infection, and/or significantly improves the healing process. The application of medical agents to the site of the traumatized tissue is often accomplished by means other than the surgical instrument that makes the incision and applies the staples. Such means generally increase the complexity and cost associated with the procedure. However, such means are often necessary because many of the surgical instruments utilized to concurrently make the incision and apply the staples are not configured to store and deliver sufficient amounts of medical agents to the site of the traumatized tissue, and the delivery of some medical agents to the site of the traumatized tissue via the surgical instrument would render the surgical instrument unsuitable for reuse.

**[0006]** The foregoing discussion is intended only to illustrate the present field and should not be taken as a disavowal of claim scope.

#### SUMMARY

**[0007]** In various embodiments, an assembly of a surgical instrument is provided. In at least one embodiment, the assembly can comprise a housing, a cutting member relatively movable with respect to the housing, and an agent cartridge connected to the housing. In these

embodiments, the cutting member can comprise a cutting surface, a body including a first surface, and a groove at least partially defined by the first surface. Further, in these embodiments, the agent cartridge can include a cavity configured to house a medical agent therein. Additionally, in these embodiments, the cutting member groove can be in fluid communication with the cavity. Moreover, in these embodiments, the groove can be configured to deliver the medical agent from the cavity proximate to the cutting surface.

**[0008]** In at least one embodiment, an assembly of a surgical instrument is provided that can comprise a housing, a member relatively movable with respect to the housing, and an agent cartridge. In these embodiments, the member can comprise a cutting surface, a body including a first surface, and a passage at least partially defined by the first surface. Further, in these embodiments, the agent cartridge can include a medical agent storage portion configured to house a medical agent therein. Additionally, in these embodiments, the member passage can be in fluid communication with the medical agent storage portion. Moreover, in these embodiments, the passage can be configured to deliver the medical agent from the medical agent storage portion proximate to the cutting surface.

**[0009]** In various embodiments, a surgical instrument is provided. In at least one embodiment, the surgical instrument can comprise a frame, a member relatively movable with respect to the frame, and an agent cartridge. In these embodiments, the member can comprise a cutting surface, a body including a first surface, and a groove at least partially defined by the first surface. Further, in these embodiments, the agent cartridge can include a medical agent storage portion configured to house a medical agent therein. Additionally, in these embodiments, the member groove can be in fluid communication with the medical agent storage portion.

Moreover, in these embodiments, the groove can be configured to deliver the medical agent from the medical agent storage portion proximate to the cutting surface.

#### BRIEF DESCRIPTION OF THE FIGURES

[0010] The novel features of the embodiments described herein are set forth with particularity in the appended claims. The embodiments, however, both as to organization and methods of operation may be better understood by reference to the following description, taken in conjunction with the accompanying drawings as follows.

[0011] FIG. 1 is a perspective view of a surgical stapling and severing instrument having a fluid actuated upper jaw (anvil) in an open position and an electroactive polymer (EAP) medical substance dispensing shaft.

[0012] FIG. 2 is a disassembled perspective view of an implement portion of the surgical stapling and severing instrument of FIG. 1.

[0013] FIG. 3 is left side view in a elevation of the implement portion of the surgical stapling and severing instrument of FIG. 1 taken in cross section generally through a longitudinal axis and passing through an offset EAP syringe and receptacle that is in fluid communication with a dispensing groove in an E-beam firing bar.

[0014] FIG. 4 is a left side detail view in elevation of a distal portion of the implement portion of the surgical stapling and severing instrument of FIG. 1 taken in cross section generally through the longitudinal axis thereof but showing a laterally offset fluid bladder actuator opening the anvil.

[0015] FIG. 5 is a left side detail view of an E-beam firing bar incorporating medical substance ducting.

[0016] FIG. 6 is a left side detail view in elevation of the distal portion of the implement portion of the surgical stapling and severing instrument of FIG. 4 taken in cross section generally through the longitudinal axis thereof with the anvil closed.

[0017] FIG. 7 is a left side detail view of the E-beam firing bar of FIG. 6.

[0018] FIG. 8 is a top detail view of a joined portion of a lower jaw (staple channel) of the end effector and elongate shaft taken in cross section through the lines 8-8 depicting guidance to the E-beam firing bar.

[0019] FIG. 9 is a front view of a firing bar guide of the implement portion of the surgical stapling and severing instrument of FIG. 2.

[0020] FIG. 10 is a left side view of the firing bar guide of FIG. 9 taken in cross section along lines 9-9.

[0021] FIG. 11 is a front view in elevation of the elongate shaft of the surgical stapling and severing instrument of FIG. 3 taken along lines 11-11 taken through a distal end of the EAP medical substance syringe.

[0022] FIG. 12 is a left side view of the EAP medical substance syringe of FIG. 11.

[0023] FIG. 13 is a left side view of the implement portion of the surgical stapling and severing instrument of FIG. 1 partially cut away to show proximal mountings for the EAP medical substance syringe.

[0024] FIG. 14 is a left side detail view of the EAP medical substance syringe and receptacle of the elongate shaft of the surgical stapling and severing instrument of FIG. 13.

[0025] FIG. 15 is a top view of the firing bar of the surgical stapling and severing instrument of FIG. 2.

[0026] FIG. 16 is a left side view of a laminate firing bar showing an internal fluid path in phantom for the surgical stapling and severing instrument of FIG. 1.

[0027] FIG. 17 is a left side detail view of an alternate E-beam showing an internal fluid path in phantom showing an internal fluid path in phantom.

[0028] FIG. 18 is a front view in elevation of the laminate firing bar of FIG. 15 taken in cross section along line 18-18 through a proximal open groove of a fluid path.

[0029] FIGS. 19-20 illustrate various embodiments of a disposable loading unit.

[0030] FIG. 21 illustrates various embodiments of an agent cartridge.

[0031] FIG. 22 illustrates various embodiments of a disposable loading unit.

[0032] FIG. 23 illustrates various embodiments of a disposable loading unit.

[0033] FIG. 24 illustrates various embodiments of a disposable loading unit.

[0034] FIG. 25 illustrates various embodiments of a disposable loading unit.

[0035] FIG. 26 illustrates various embodiments of a disposable loading unit.

[0036] FIG. 27 illustrates various embodiments of a disposable loading unit.

[0037] FIG. 28 illustrates various embodiments of a disposable loading unit.

[0038] FIG. 29 illustrates various embodiments of a disposable loading unit.

[0039] FIG. 30 illustrates various embodiments of a disposable loading unit.

[0040] FIG. 31 illustrates various embodiments of a disposable loading unit.

[0041] FIG. 32 illustrates various embodiments of a disposable loading unit.

[0042] FIG. 33 illustrates various embodiments of a surgical instrument.

DETAILED DESCRIPTION

[0043] It is to be understood that the figures and descriptions of the disclosed embodiments have been simplified to illustrate elements that are relevant for a clear understanding of the disclosed embodiments, while eliminating, for purposes of clarity, other elements. Those of ordinary skill in the art will recognize, however, that these and other elements may be desirable. However, because such elements are well known in the art, and because they do not facilitate a better understanding of the disclosed embodiments, a discussion of such elements is not provided herein.

[0044] Certain embodiments will now be described to provide an overall understanding of the principles of the structure, function, manufacture, and use of the devices and methods disclosed herein. One or more examples of these embodiments are illustrated in the accompanying drawings. Those of ordinary skill in the art will understand that the devices and methods specifically described herein and illustrated in the accompanying drawings are non-limiting embodiments and that the scope of these embodiments is defined solely by the claims. The features illustrated or described in connection with one embodiment may be combined with the features of other embodiments. Further, where an ordering of steps in a process is indicated, such ordering may be rearranged or the steps may be carried out contemporaneously as desired unless illogical or the listed order is explicitly required. Such modifications and variations are intended to be included within the scope of the appended claims.

[0045] Also, in the following description, it is to be understood that terms such as "forward," "rearward," "front," "back," "right," "left," "over," "under," "top," "bottom," "upwardly," "downwardly," "proximally," "distally," and the like are words of convenience and

are not to be construed as limiting terms. The description below is for the purpose of describing various embodiments and is not intended to limit the appended claims.

**[0046]** Turning to the drawings, wherein like numerals denote like components throughout the several views, in FIGS. 1-2, a surgical stapling and severing instrument 10 that is capable of practicing the unique benefits of at least one embodiment, including both fluid actuation (e.g., opening, closing/clamping) of an upper jaw (anvil) 12 of an end effector 14 as well as dispensing a medical substance onto tissue as severed. Fluid actuation of the end effector 14 provides a range of design options that avoid some design limitations of traditional mechanical linkages. For example, instances of binding or component failure may be avoided. Further, dispensing liquids onto severed tissue allows for a range of advantageous therapeutic treatments to be applied, such as the application of anesthetics, adhesives, cauterizing substances, antibiotics, coagulant, etc.

**[0047]** With particular reference to FIG. 2, the surgical stapling and severing instrument 10 includes an implement portion 16 formed by an elongate shaft 18 and the end effector 14, depicted as a stapling assembly 20. The surgical stapling and severing instrument 10 also includes a handle 22 (FIG. 1) attached proximally to the shaft 18. The handle 22 remains external to the patient as the implement portion 16 is inserted through a surgical opening, or especially a cannula of a trocar that forms a pneumoperitoneum for performing a minimally invasive surgical procedure.

**[0048]** Left and right fluid bladders (lift bags) 24, 26 are supported within an aft portion 28 of a staple channel 30. The anvil 12 includes a pair of inwardly directed lateral pivot pins 32, 34 that pivotally engage outwardly open lateral pivot recesses 36, 38 formed in the staple channel 30 distal to the aft portion 28. The anvil 12 includes a proximally directed lever tray 40

that projects into the aft portion 28 of the staple channel 30 overtop and in contact with the fluid bladders (lift bags) 24, 26 such that filling the fluid bladders 24, 26 causes a distal clamping section 41 of the anvil 12 to pivot like a teeter-totter toward a staple cartridge 42 held in a distal portion 44 of the staple channel 30. Evacuation and collapse of the fluid bladders 24, 26, or some other resilient feature of the end effector 14, causes the anvil 12 to open. Left and right fluid conduits 46, 48 communicate respectively with the left and right fluid bladders 24, 26 to bi-directionally transfer fluid for actuation. It should be appreciated that applications consistent with the present embodiment may include a mechanical actuation in the handle 22 (e.g., closure trigger) (not shown) wherein the user depresses a control that causes closure and clamping of the end effector 12.

[0049] It will be appreciated that the terms "proximal" and "distal" are used herein with reference to a clinician gripping a handle of an instrument. Thus, the staple applying assembly 20 is distal with respect to the more proximal handle 22. It will be further appreciated that, for convenience and clarity, spatial terms such as "vertical" and "horizontal" are used herein with respect to the drawings. However, surgical instruments are used in many orientations and positions, and these terms are not intended to be limiting and absolute.

[0050] With particular reference to FIG. 2, the elongate shaft 18 includes a frame 50 whose proximal end is rotatably engaged to the handle 22 (FIG. 1) such that a rotation knob 52 rotates the frame 50 along with the end effector 14. A distal end of the frame 50 has lateral recesses 54 that engage a proximal lip 56 of the staple channel 30. The frame 50 includes a laterally centered, bottom firing slot 58 that passes longitudinally through the frame 50 for receiving a two-piece firing bar 60 comprised of a firing bar 62 with a distally attached E-beam 64, the latter translating within the staple applying assembly 20 to sever and staple tissue. A

distal portion of the frame 50 includes an upper cavity 66 whose distal and proximal ends communicate through distal and proximal apertures 68, 70, defining there between a cross bar 72 over which a distally projecting clip 74 of a clip spring 76 engages with a lower spring arm 78, distally and downwardly projecting through the upper cavity 66 to bias the firing bar 62 downwardly into engagement with the staple channel 30, especially when the lower spring arm 78 encounters a raised portion 80 on the firing bar 62.

**[0051]** Medical substance dispensing is integrated into the elongate shaft 18 by including a laterally offset cylindrical cavity 90 formed in the frame 50 that communicates along its longitudinal length to the outside via a rectangular aperture 92 that is slightly shorter than an electroactive polymer (EAP) syringe 100 that is inserted through the aperture 92 into the cylindrical cavity 90. A proximal portion of the cylindrical cavity 90 contains a longitudinally aligned compression spring 102 that urges a distal dispensing cone 104 of the EAP syringe 100 distally into sealing contact with the frame 50 and allows translation for insertion and removal of the EAP syringe 100. An electrical conductor 106 passes through the frame 50 and is attached to the compression spring 102, which is also formed of an electrically conductive metal. An aft portion of the EAP syringe 100 is conductive and contacts the spring 102 to form a cathode to an EAP actuator 110 held in a proximal portion of the EAP syringe 100. It will be appreciated that another conductor, perhaps traveling with the conductor 106, also electrically communicates to the EAP actuator 110 to serve as the anode.

**[0052]** When activated, the EAP actuator 110 longitudinally expands, serving as a plunger to dispel a medical substance 112 in a distal portion of the EAP syringe 100 through the distal dispensing cone 104. Insofar as the EAP actuator 110 laterally contracts to compensate for its longitudinal expansion, a plunger seal 114 maintains a transverse seal within the EAP syringe

100. An vent (not shown), such as around conductor 106 allows air to refill the EAP syringe 100 behind the plunger seal 114 as the medical substance 112 is dispensed. The vent may rely upon the surface tension of the medical substance 112 to avoid leaking or be a one-way valve. As described below, the medical substance 112 is conducted by the frame 50 to a lateral fluid groove 120 that is formed in the firing bar 62 and the E-beam 64 to direct the medical substance to a cutting surface 122 of the E-beam 64. The frame slot 58 is sized to seal the lateral fluid groove 120. The portion of the lateral fluid groove 120 that is positioned under the spring clip 76 is sealed by a firing bar guide 124. In the illustrative version, an outer sheath 130 encompasses the frame 50 and proximally projecting lever tray 40 of the anvil 12. A top distal opening 131 allows closing of the anvil 12.

**[0053]** An outer rectangular aperture 132 of the outer sheath 130 is sized and longitudinally positioned to correspond to the rectangular aperture 92 formed in frame 50. In some applications, the outer sheath 130 may be rotated to selectively align the rectangular aperture 92 with the outer rectangular aperture 132 for insertion or removal of the EAP syringe 100. It should be appreciated that in some applications that the EAP syringe 100 may be integrally assembled into an elongate shaft that does not allow for selecting a desired medical substance. For instance, a disposable implement portion with an integral staple cartridge and medical dispensing reservoir may be selected by the clinician as a unit. It is believed that allowing insertion at the time of use, though, has certain advantages including clinical flexibility in selecting a medical substance (e.g., anesthetics, adhesives, antibiotics, cauterizing compound, etc.) and extending the shelf life/simplifying storage and packaging of the implement portion 16.

**[0054]** In the illustrative version, an elongate stack of many disk-shaped EAP layers are aligned longitudinally and configured to expand along this longitudinal axis. Electroactive

polymers (EAPs) are a set of conductive doped polymers that change shape when electrical voltage is applied. In essence, the conductive polymer is paired to some form of ionic fluid or gel and electrodes. Flow of the ions from the fluid/gel into or out of the conductive polymer is induced by the voltage potential applied and this flow induces the shape change of the polymer. The voltage potential ranges from IV to 4 kV, depending on the polymer and ionic fluid used. Some of the EAPs contract when voltage is applied and some expand. The EAPs may be paired to mechanical means such as springs or flexible plates to change the effect that is caused when the voltage is applied.

**[0055]** There are two basic types of EAPs and multiple configurations of each type. The two basic types are a fiber bundle and a laminate version. The fiber bundle consists of fibers around 30-50 microns. These fibers may be woven into a bundle much like textiles and are often called EAP yarn because of this. This type of EAP contracts when voltage is applied. The electrodes are usually made up of a central wire core and a conductive outer sheath that also serves to contain the ionic fluid that surrounds the fiber bundles. An example of a commercially available fiber EAP material, manufactured by Santa Fe Science and Technology and sold as PANION™ fiber, is described in U.S. Pat. No. 6,667,825, which is hereby incorporated by reference in its entirety.

**[0056]** The other type is a laminate structure, which consists of a layer of EAP polymer, a layer of ionic gel and two flexible plates that are attached to either side of the laminate. When a voltage is applied, the square laminate plate expands in one direction and contracts in the perpendicular direction. An example of a commercially available laminate (plate) EAP material is from Artificial Muscle Inc, a division of SRI Laboratories. Plate EAP material is manufactured by EAMEX of Japan and is referred to as thin film EAP.

**[0057]** It should be noted that EAPs do not change volume when energized; they merely expand or contract in one direction while doing the opposite in the transverse direction. The laminate version may be used in its basic form by containing one side against a rigid structure and using the other much like a piston. The laminate version may also be adhered to either side of a flexible plate. When one side of the flexible plate EAP is energized, it expands flexing the plate in the opposite direction. This allows the plate to be flexed in either direction, depending on which side is energized.

**[0058]** An EAP actuator usually consists of numerous layers or fibers bundled together to work in cooperation. The mechanical configuration of the EAP determines the EAP actuator and its capabilities for motion. The EAP may be formed into long strands and wrapped around a single central electrode. A flexible exterior outer sleeve will form the other electrode for the actuator as well as contain the ionic fluid necessary for the function of the device. In this configuration when the electrical field is applied to the electrodes, the strands of EAP shorten. This configuration of EAP actuator is called a fiber EAP actuator. Likewise, the laminate configuration may be placed in numerous layers on either side of a flexible plate or merely in layers on itself to increase its capabilities. Typical fiber structures have an effective strain of 2-4% where the typical laminate version achieves 20-30%, utilizing much higher voltages.

**[0059]** For instance, a laminate EAP composite may be formed from a positive plate electrode layer attached to an EAP layer, which in turn is attached to an ionic cell layer, which in turn is attached to a negative plate electrode layer. A plurality of laminate EAP composites may be affixed in a stack by adhesive layers there between to form an EAP plate actuator. It should be appreciated that opposing EAP actuators may be formed that can selectively bend in either direction.

**[0060]** A contracting EAP fiber actuator may include a longitudinal platinum cathode wire that passes through an insulative polymer proximal end cap through an elongate cylindrical cavity formed within a plastic cylinder wall that is conductively doped to serve as a positive anode. A distal end of the platinum cathode wire is embedded into an insulative polymer distal end cap. A plurality of contracting polymer fibers are arranged parallel with and surrounding the cathode wire and have their ends embedded into respective end caps. The plastic cylinder wall is peripherally attached around respective end caps to enclose the cylindrical cavity to seal in ionic fluid or gel that fills the space between contracting polymer fibers and cathode wire. When a voltage is applied across the plastic cylinder wall (anode) and cathode wire, ionic fluid enters the contracting polymer fibers, causing their outer diameter to swell with a corresponding contraction in length, thereby drawing the end caps toward one another.

**[0061]** Returning to FIG. 1, the handle 22 controls closure of the anvil 12, firing of the two-piece firing bar 60 (FIG. 2), and dispensing of the medical substance. In an illustrative version, a pistol grip 140 may be grasped and a thumb button 142 depressed as desired to control closure of the anvil 12. The thumb button 142 provides a proportional electrical signal to an EAP dispensing actuator (not shown) similar to the EAP syringe 100 to transfer fluid through the conduits 46, 48 to the fluid bladders 24, 26 to close the anvil 12 (FIG. 2). When the thumb button 142 is fully depressed, a mechanical toggle lock (not shown) engages to hold the thumb button 142 down until a full depression releases the toggle lock for releasing the thumb button 142. Thus, when the thumb button 142 is held down, the surgeon has a visual indication that the end effector 14 is closed and clamped, which may be maintained in this position by continued activation of an EAP dispensing actuator or by a locking feature. For instance, control circuitry may sense movement of the thumb button 142, causing a normally closed EAP shutoff valve (not

shown) to open that communicates between the EAP dispensing actuator and the conduits 46, 48. Once movement ceases, the EAP shutoff valve is allowed to close again, maintaining the anvil 12 position. In addition, a manual release could be incorporated to defeat such a lockout to open the anvil 12.

**[0062]** As an alternative, a closure trigger (not shown) or other actuator may be included that bi-directionally transfers fluid to the fluid bladders 24, 26 as described in commonly owned U.S. Pat. Application. 11/061,908 entitled "SURGICAL INSTRUMENT INCORPORATING A FLUID TRANSFER CONTROLLED ARTICULATION MECHANISM" to Kenneth Wales and Chad Boudreaux, filed on 18 Feb., 2005, the disclosure of which is hereby incorporated by reference in its entirety. A number of such fluid actuators for articulation of a pivoting shaft are described that may be adapted for closing the anvil 12. To take full advantage of the differential fluid transfer described for several of these versions, it should be appreciated that an opposing lift bag (not shown) may be placed above the lever tray 40 of the anvil 12 to assert an opening force as the left and right fluid bladders (lift bags) 24, 26 collapse.

**[0063]** With particular reference to FIG. 3, the handle 22 includes a firing trigger 150 (FIG. 1) that is drawn proximally toward the pistol grip 140 to cause a firing rod 152 to move distally in a proximal portion 154 of the elongate shaft 18. A distal bracket 156 of the firing rod 152 engages an upward proximal hook 158 of the firing bar 62. A dynamic seal 160 within the frame 50 seals to the firing rod 152 so that the implement portion 16 is pneumatically sealed when inserted into an insufflated abdomen.

**[0064]** An anti-backup mechanism 170 of the firing rod 152 may be advantageously included for a handle 22 that includes a multiple stroke firing trigger 150 and a retraction biased firing mechanism coupled to the firing rod 152 (not shown). In particular, an anti-backup

locking plate 172 has the firing rod 152 pass through a closely fitting through hole (not shown) that binds when a retracting firing rod 152 tips the lock plate 172 backward as shown with the bottom of the locking plate 172 held in position within the frame 50. An anti-backup cam sleeve 174 is positioned distal to the anti-backup locking plate 172 and urged into contact by a more distal compression spring 176 through which the firing rod 152 passes and that is compressed within the frame 50. It should be appreciated that mechanisms in the handle 22 may manually release the anti-backup mechanism 170 for retraction of the firing rod 152.

**[0065]** In FIGS. 4-5, the end effector 14, which in the illustrative version is a staple applying assembly 20, is opened by having fluid bladder 24 deflated, drawing down lever tray 40 of the anvil 12, which pivots about pin 32 raising distal clamping section 41 thereby allowing positioning body tissue 180 between the anvil 12 and staple cartridge 42. The E-beam 64 has an upper pin 182 that resides within an anvil pocket 184 allowing repeated opening and closing of the anvil 12. An anvil slot 186 formed along the length of the anvil 12 receives the upper pin 182 when the anvil 12 is closed and the two piece firing bar 60 is distally advanced. A middle pin 188 slides within the staple cartridge 42 above the staple channel 30 in opposition to a bottom pin or foot 190 that slides along a bottom surface of the staple channel 30.

**[0066]** In FIGS. 6-7, the staple applying assembly 20 has been closed by expanding the fluid bladder (lift bag) 24, raising the lever tray 40 of the anvil 12 until flush with the outer sheath 130, with a proximal upwardly bent tip 192 of the lever tray 40 allowed to enter the top distal opening 131. This bent tip 192 in combination with the opening 131, advantageously allows greater radial travel for the anvil 12 as well as presenting an abutting surface rather than a piercing tip to the underlying fluid bladder 24. When the anvil 12 is closed, the upper pin 182 is

aligned with the anvil slot 186 for firing and the tissue 180 is flattened to a thickness appropriate for severing and stapling.

**[0067]** In FIGS. 7-8, the E-beam 64 is cut away to show its bottom foot 190 riding along a downwardly open laterally widened recess 200 that communicates with a narrow longitudinal slot 202 through which a vertical portion 204 of the E-beam 64 passes. A proximal aperture 206 to the narrow longitudinal slot 202 allows an assembly entrance for the lower foot 190. A bottom bump 208 is positioned on the firing bar 62 to drop into the proximal aperture 206 during an initial portion of firing travel under the urging of the clip spring 76 (FIG. 6) against the raised portion 80 of the firing bar 62 for proper engagement and for possible interaction with an end effector firing lockout mechanism (not shown). Also, this position allows for the end effector 14 to be pinched shut to facilitate insertion through a surgical entry point such as a cannula of a trocar (not shown). With reference to FIGS. 8-10, the firing bar guide 124 laterally contacts a portion of the firing bar 62 to close the corresponding portion of the lateral fluid groove 120. In FIG. 11, the EAP syringe 100 in the cylindrical cavity 90 has its distal dispensing cone 104 communicating with a radial fluid passage 220 formed in the frame 50 that communicates in turn with the lateral fluid groove 120. In FIG. 12, before installation in the surgical stapling and severing instrument 10, the EAP syringe 100 may be advantageously sealed with a disposable cap 230. In FIGS. 13-14, the EAP syringe 100 is shown without the disposable cap 230 and urged by spring 102 distally to engage the distal dispensing cone 104 into communication with the radial fluid passage 220.

**[0068]** It should be appreciated that one or more sensor in the surgical stapling and severing instrument 10 may sense a firing condition (c.g., movement of firing bar or mechanism

coupled to the firing bar, position of the firing trigger, a separate user control to dispense, etc.) and activate dispensing control circuitry to effect dispensing.

**[0069]** In FIGS. 15-18, an alternate two-piece firing bar 300 is formed from longitudinally laminated left half and right half firing bar portions 302, 304 that form a firing bar 305 and attached to an E-beam 309. Thereby, fluid transfer down the firing bar 300 may be further constrained. In particular, a left side fluid groove 310 in the left half firing bar portion 302 transitions distally to a pair of aligned internal fluid grooves 312, 314 respectively in the left and right half firing bar portions 302, 304, defining an internal fluid passage 316. Since the E-beam 309 is laterally thicker and of short longitudinal length, a drilled fluid passage 320 is formed therein between a cutting surface 322 and an aft edge aligned to communicate with the internal fluid passage 316.

**[0070]** While the present embodiment has been illustrated by description of several embodiments and while the illustrative embodiments have been described in considerable detail, it is not the intention of the applicant to restrict or in any way limit the scope of the appended claims to such detail. Additional advantages and modifications may readily appear to those skilled in the art.

**[0071]** For example, while a non-articulating shaft is described herein for clarity, it should be appreciated that medical substance dispensing may be incorporated into an articulating shaft. In addition, fluid conduits may be incorporated that pass through an articulation joint of a shaft to fluid bladder actuators that close an end effector.

**[0072]** As another example, while both medical substance dispensing and fluid actuated anvil closing are illustrated herein, applications consistent with aspects of various embodiments may include either of these features. Further, for applications in which an adhesive and/or

cauterizing medical substance is dispensed, it should be appreciated that features such as staples may be omitted.

[0073] As another example, while a staple applying assembly 20 is illustrated herein, it should be appreciated that other end effectors (graspers, cutting devices, etc.) may benefit from either or both of fluid controlled closing and medical substance dispensing.

[0074] As yet another example, a receptacle for the EAP syringe may be formed in the handle rather than in the elongate shaft.

[0075] As yet an additional example, a symmetric arrangement for a second EAP syringe may be formed in the elongate channel so that two medical substances may be simultaneously dispensed during firing.

[0076] As yet a further example, while a staple applying apparatus provides an illustrative embodiment, it should be appreciated that other endoscopic instruments may benefit from the ability to dispense a liquid at or near a distal end thereof. Examples of instruments that may benefit include, but are not limited to, an ablation device, a grasper, a cauterizing tool, an anastomotic ring introduction device, a surgical stapler, a linear stapler, etc. As such, those instruments that do not employ a firing bar that serves herein as a convenient fluid passage to a cutting surface may instead incorporate ducting or fluid conduits to an appropriate location.

[0077] While an electroactive polymer plunger has various advantages, it should be appreciated that other types of actuated devices may be employed to dispense a medical substance to the end effector.

[0078] For example, FIGS. 19-20 illustrate various embodiments of a disposable loading unit 1010, with FIG. 20 showing an exploded view of the disposable loading unit 1010. The disposable loading unit 1010 includes a first end 1012 configured for releasable connection to a

surgical instrument (see FIG. 33), and a second end 1014 opposite the first end 1012. The disposable loading unit 1010 comprises a housing assembly 1016, an agent cartridge 1018, a knife assembly 1020, a staple cartridge 1022, and an anvil assembly 1024. The disposable loading unit 1010 may be removed and discarded after a single use.

**[0079]** The housing assembly 1016 comprises a channel 1026 and a channel cover 1028 connected to the channel 1026. The channel 1026 and the channel cover 1028 may be fabricated from any suitable material such as, for example, a plastic. The channel 1026 includes a first end 1030 proximate the first end 1012 of the disposable loading unit 1010 and a second end 1032 proximate the second end 1014 of the disposable loading unit 1010. The channel 1026 comprises a base 1034, a first wall 1036, and a second wall 1038. According to various embodiments, the base 1034 defines an opening 1040 proximate the first end 1030 of the channel 1026, a first slot 1042 proximate the first end 1030 of the channel 1026, a second slot 1044 proximate the first end 1030 of the channel 1026, and a third slot 1046 proximate the second end 1032 of the channel. The first wall 1036 is connected to the base 1034 and extends generally perpendicular therefrom. The second wall 1038 is connected to the base 1034, extends generally perpendicular therefrom, and is opposite the first wall 1036. The second wall 1038 may be a mirror-image of the first wall 1036, and the first and second walls 1036, 1038 may be fabricated integral with the base 1034. According to various embodiments, each of the first and second walls 1036, 1038 define a fourth slot 1048, a first tab 1050, a first indent 1052, a fifth slot 1054, a second indent 1056, a sixth slot 1058, a third indent 1060, a fourth indent 1062, a seventh slot 1064, an eighth slot 1066, and a first flange 1068.

**[0080]** The channel cover 1028 includes a first end 1070 proximate the first end 1012 of the disposable loading unit 1010 and a second end 1072 opposite the first end 1070, and may be

symmetric along an axis that extends from the first end 1070 of the channel cover 1028 to the second end 1072 of the channel cover 1028. The channel cover 1028 is configured to engage with the channel 1026 at a plurality of locations. According to various embodiments, the channel cover 1028 defines a pair of coupling pegs 1074 proximate the first end 1070 of the channel cover 1028 that extends from the channel cover 1028. One of the coupling pegs 1074 passes through the opening 1040 defined by the channel 1026. The channel cover 1028 also defines a slit 1076 proximate the second end 1072 of the channel cover 1028. According to various embodiments, the channel cover 1028 defines a first pair of tabs 1078 that pass through and engage with the fourth slots 1048, a first pair of interior projections that mate with the first indents 1052, a second pair of tabs 1080 that pass through and engage with the fifth slots 1054, a second pair of interior projections that mate with the second indents 1056, and a third pair of interior projections that engage with the sixth slots 1058. According to other embodiments, the channel 1026 and the channel cover 1028 may be fabricated to include other arrangements of tabs, slots, projections, indents, etc. that may be utilized to connect the channel cover 1028 to the channel 1026.

**[0081]** The agent cartridge 1018 is connected to the housing assembly 1016 and houses at least one medical agent. The medical agent may be any type of medical agent. For example, the medical agent may comprise an anesthetic, an adhesive, an antibiotic, a cauterizing substance, a coagulant, a growth hormone, a hemostatic agent, a sealant, etc., or any combination thereof.

**[0082]** The agent cartridge 1018 includes a first end 1082 proximate the first end 1012 of the disposable loading unit 1010 and a second end 1084 opposite the first end 1082. The agent cartridge 1018 comprises a body 1086 (see FIG. 24) that may be fabricated from any suitable material (e.g., a plastic) that is compatible with the medical agent. According to various

embodiments, the body 1086 comprises a first section 1088 and a second section 1090. The first section 1088 may define a first spline that extends therefrom, and passes through and engages with the first slot 1042 of the base 1034 of the channel 1026. As shown in FIG. 21, the first section 1088 may also define a first projection 1094 and a first dispensing port 1096 proximate the second end 1084 of the agent cartridge 1018. The first projection 1094 may be of any shape (e.g., rectangular, triangular, hemispherical, etc.). The first dispensing port 1096 is positioned between the first projection 1094 and the second end 1084 of the agent cartridge 1018. The second section 1090 is spaced apart from the first section 1088 and may be a mirror-image thereof. The second section 1090 may define a second spline that extends therefrom, and passes through and engages with the second slot 1044 of the base 1034 of the channel 1026. As shown in FIG. 21, the second section 1090 may define a second projection 1100 and a second dispensing port 1102 proximate the second end 1084 of the agent cartridge 1018. The second projection 1100 may be of any shape (e.g., rectangular, triangular, hemispherical, etc.). The second dispensing port 1102 is positioned between the second projection 1100 and the second end 1084 of the agent cartridge 1018. According to other embodiments, the body 1086 may be fabricated to include other arrangements of splines, tabs, fasteners, etc. that may be utilized to connect the agent cartridge 1018 to the housing assembly 1016.

**[0083]** According to various embodiments, the agent cartridge 1018 also comprises a first sealing member 1104 (see FIG. 21) and a second sealing member 1106 (see FIG. 21). The first sealing member 1104 is connected to the first section 1088 and cooperates with the first section 1088 to house a medical agent. Similarly, the second sealing member 1106 is connected to the second section 1090 and cooperates with the second section 1090 to house a second medical agent. The first medical agent may be the same or different than the second medical agent.

**[0084]** The knife assembly 1020 is connected to the housing assembly 1016, and includes a first end 1108 proximate the first end 1012 of the disposable loading unit 1010 and a second end 1110 opposite the first end 1108. The knife assembly 1020 comprises a body 1112 and a cutting surface 1114. According to various embodiments, the cutting surface 1114 comprises a portion of a knife blade that is connected to the body 1112 proximate the second end 1110 of the knife assembly 1020. The body 1112 may be fabricated from any suitable material such as, for example, a plastic. According to various embodiments, the body 1112 comprises a first clamping member 1116 proximate the first end 1108 of the knife assembly 1020, a second clamping member 1118 proximate the first end 1108 of the knife assembly 1020, and a foot member 1120 proximate the second end 1110 of the knife assembly 1020. The foot member 1120 passes through the third slot 1046 of the base 1034 of the channel 1026 and is mated with a retainer 1122 that is external to the housing assembly 1016 and serves to slidably connect the body 1112 to the housing assembly 1016 such that the knife assembly 1020 can be selectively advanced along the third slot 1046 toward the second end 1032 of the channel 1026.

**[0085]** The body 1112 of the knife assembly 1020 also comprises a first surface 1124 and a second surface 1126 (see FIG. 24) that is opposite the first surface 1124. The first surface 1124 of the body 1112 is adjacent the first section 1088 of the agent cartridge 1018, and the second surface 1126 of the body 1112 is adjacent the second section 1090 of the agent cartridge 1018. The first surface 1124 of the body 1112 defines a first groove 1128 and the second surface 1126 of the body 1112 defines a second groove 1130 (see FIG. 24). The first groove 1128 is proximate the cutting surface 1114 of the knife assembly 1020 and may extend any distance along the first surface 1124 of the body 1112 toward the first end 1108 of the knife assembly 1020. The first groove 1128 is adjacent the first dispensing port 1096 and is configured to

receive the first projection 1094 of the first section 1088 of the body 1086. The second groove 1130 is proximate the cutting surface 1114 of the knife assembly 1020 and may extend any distance along the second surface 1126 of the body 1112 toward the first end 1108 of the knife assembly 1020. The second groove 1130 is adjacent the second dispensing port 1102 and is configured to receive the second projection 1100 of the second section 1090 of the body 1086. Each of the first and second grooves 1128, 1130 may be of any shape (e.g., rectangular, triangular, hemispherical, etc.) suitable for respectively receiving the first projection 1094 and the second projection 1100. The body 1112 of the knife assembly 1020 may also define an opening 1132 that extends from the first surface 1124 to the second surface 1126 proximate the second end 1110 of the knife assembly 1020.

**[0086]** The staple cartridge 1022 is connected to the housing assembly 1016. The staple cartridge 1022 includes a first end 1134 and a second end 1136 opposite the first end 1134. The second end 1136 of the staple cartridge 1022 is proximate the second end 1014 of the disposable loading unit 1010. The staple cartridge 1022 may be similar to other staple cartridges known in the art. For example, the staple cartridge 1022 may comprise a plurality of surgical fasteners and a plurality of corresponding pushers. According to various embodiments, the staple cartridge 1022 defines a slot 1142 that is aligned with the third slot 1046 of the base 1034 of the channel 1026 and extends from the first end 1134 of the staple cartridge 1022 toward the second end 1136 of the staple cartridge 1022. The staple cartridge 1022 may also define tabs that extend from the staple cartridge 1022 and pass through and engage with the seventh slots 1064 and the eighth slots 1066 of the channel 1026, and may further comprise flanges 1146 which frictionally engage the first and second walls 1036, 1038 of the channel 1026 proximate the second end 1032 of the channel 1026. According to other embodiments, the staple cartridge 1022 may be

fabricated to include other arrangements of tabs, flanges, fasteners, etc. that may be utilized to connect the staple cartridge 1022 to the housing assembly 1016.

[0087] The anvil assembly 1024 is connected to the housing assembly 1016. The anvil assembly 1024 includes a first end 1148 and a second end 1150 opposite the first end 1148. The second end 1150 of the anvil assembly 1024 is proximate the second end 1014 of the disposable loading unit 1010. The anvil assembly 1024 may be similar to other anvil assemblies known in the art. For example, the anvil assembly 1024 is moveable between an open position and a closed position, and may comprise an anvil plate 1152 and an anvil body 1154 connected to the anvil plate 1152. According to various embodiments, the anvil plate 1152 defines a slot 1156 that is aligned with the slot 1142 of the staple cartridge 1022, and the anvil body 1154 defines a slot 1158 that is aligned with the slot 1156 of the anvil plate 1152. The anvil plate 1152 may also define a first pair of ears 1160 proximate the first end 1148 of the anvil assembly 1024 and a second pair of ears 1162 positioned between the first pair of ears 1160 and the second end 1150 of the anvil assembly 1024. One of the ears of the second pair of ears 1162 is engaged with the third indent 1060 defined by the first wall 1036 of the channel 1026, and the other ear of the second pair of ears 1162 is engaged with the third indent 1060 defined by the second wall 1038 of the channel 1026. A spring member 1164 or other biasing arrangement may be utilized to urge the anvil assembly 1024 to the open position, and an anvil pin 1166 that passes through the opening 1132 of the knife assembly 1020 may be utilized to urge the anvil assembly 1024 toward the closed position. According to other embodiments, the anvil assembly 1024 may be fabricated to include other fastener arrangements that may be utilized to connect the anvil assembly 1024 to the housing assembly 1016.

**[0088]** The disposable loading unit 1010 may further comprise a first medical agent driver 1168 proximate the first end 1082 of the agent cartridge 1018 and a second medical agent driver 1170 (see FIG. 24) proximate the first end 1082 of the agent cartridge 1018. According to various embodiments, the first and second medical agent drivers 1168, 1170 may comprise a portion of a drive block 1172 that is coupled to the knife assembly 1020 at the first end 1108 thereof. For such embodiments, the first medical agent driver 1168 may be configured to slidably fit within the first section 1088 of the body 1086 of the agent cartridge 1018, and the second medical agent driver 1170 may be configured to slidably fit within the second section 1090 of the body 1086 of the agent cartridge 1018. According to other embodiments, the first medical agent driver 1168 may comprise an electrically activated polymer that is in contact with the first section 1088 of the body 1086 of the agent cartridge 1018 as shown in FIGS. 13 and 14. Similarly, the second medical agent driver 1170 may comprise an electrically activated polymer that is in contact with the second section 1090 of the body 1086 of the agent cartridge 1018. For such embodiments, each of the first and second medical agent drivers 1168, 1170 may be electrically connected to a contact 1174 (see FIG. 32) that is proximate the first end 1012 of the disposable loading unit 1010 and is connected to a voltage source.

**[0089]** As shown in FIG. 2, the disposable loading unit 1010 may also comprise a lock member 1176 connected to the drive block 1172, a retainer 1178 for coupling the lock member 1176 to the drive block 1172, and a sled 1180 positioned proximate the second end 1110 of the knife assembly 1020. The drive block 1172, the lock member 1176, the retainer 1178 and the sled 1180 may be similar to those known in the art. The disposable loading unit 1010 may further comprise a firing member adapter 1182 connected to the drive block 172. The firing

member adapter 1182 is configured for receiving a firing member that does not comprise a portion of the disposable loading unit 1010.

**[0090]** FIG. 22 illustrates various embodiments of the disposable loading unit 1010. For purposes of clarity only, certain portions of the disposable loading unit 1010 are not shown in this figure. The first and second clamping members 1116, 1118 are connected to the drive block 1172, and the lock member 1176 and the retainer 1178 are also connected to the drive block 1172. The first medical agent driver 1168 is connected to the drive block 1172, and the sled 1180 is proximate the second end 1110 of the knife assembly 1020. The general positions of the shown components relative to the channel 1026 represent the positions of the components prior to the advancement of the firing member (i.e., the pre-fire positions).

**[0091]** FIG. 23 illustrates various embodiments of the disposable loading unit 1010. For purposes of clarity only, certain portions of the disposable loading unit 1010 are not shown in this figure. FIG. 23 is similar to FIG. 22, and shows that the first medical agent driver 1168 is aligned with the first section 1088 of the body 1086 of the agent cartridge 1018. The general positions of the shown components relative to the channel 1026 represent the positions of the components prior to the advancement of the firing member (i.e., the pre-fire positions).

**[0092]** FIG. 24 illustrates various embodiments of the disposable loading unit 1010, and shows a cross-section of the disposable loading unit 1010 along line 6-6 of FIG. 23. As shown in FIG. 24, the first and second dispensing ports 1096, 1102 may pass through the respective first and second sections 1088, 1090 at an angle relative to the base 1034 of the channel 1026.

**[0093]** FIG. 25 illustrates various embodiments of the disposable loading unit 1010. For purposes of clarity only, certain portions of the disposable loading unit 1010 are not shown in this figure. The anvil assembly 1024 is shown in the open position relative to the staple cartridge

1022 in FIG. 25. The general positions of the shown components relative to the channel 1026 represent the positions of the components prior to the advancement of the firing member (i.e., the pre-fire positions).

**[0094]** FIG. 26 illustrates various embodiments of the disposable loading unit 1010. For purposes of clarity only, certain portions of the disposable loading unit 1010 are not shown in this figure. FIG. 26 is similar to FIG. 25, but also shows the first section 1088 of the body 1086 of the agent cartridge 1018.

**[0095]** FIG. 27 illustrates various embodiments of the disposable loading unit 1010, and is an enlarged version of a portion of the disposable loading unit 1010 illustrated in FIG. 26.

**[0096]** FIG. 28 illustrates various embodiments of the disposable loading unit 1010, and is an enlarged version of a portion of the disposable loading unit 1010 illustrated in FIG. 26.

**[0097]** FIG. 29 illustrates various embodiments of the disposable loading unit 1010. For purposes of clarity only, certain portions of the disposable loading unit 1010 are not shown in this figure. The general positions of the shown components relative to the channel 1026 represent the positions of the components after the advancement of the firing member (i.e., the post-fire positions). As shown in FIG. 29, the anvil assembly 1024 is in the closed position, and the post-fire positions of the knife assembly 1020, the anvil assembly 1024, the first medical agent driver 1168, the drive block 1172, and the lock member 1176 are different than their pre-fire positions relative to the channel 1026.

**[0098]** FIG. 30 illustrates various embodiments of the disposable loading unit 1010, and is an enlarged version of a portion of the disposable loading unit 1010 illustrated in FIG. 29. As shown in FIG. 30, the post-fire position of the first medical agent driver 1168 may be some

distance from the first dispensing port 1096. Similarly, the post-fire position of the second medical agent driver 1170 may be some distance from the second dispensing port 1102.

**[0099]** FIG. 31 illustrates various embodiments of the disposable loading unit 1010. For purposes of clarity only, certain portions of the disposable loading unit 1010 are not shown in this figure. FIG. 31 is similar to FIG. 22, but shows the first section 1088 of the body 1086 of the agent cartridge 1018, and also shows the first medical agent driver 1168 embodied as an electrically activated polymer. FIG. 31 also illustrates the conductors 1184 that electrically connect the first medical agent driver 1168 and the contact 1174. The general positions of the shown components relative to the channel 1026 represent the positions of the components prior to the advancement of the firing member (i.e., the pre-fire positions).

**[0100]** FIG. 32 illustrates various embodiments of the disposable loading unit 1010. For purposes of clarity only, certain portions of the disposable loading unit 1010 are not shown in this figure. FIG. 32 is similar to FIG. 26, but shows the first medical agent driver 1168 embodied as an electrically activated polymer. FIG. 32 also illustrates the contact 1174 and the conductors 1184 that electrically connect the contact 1174 and the first medical agent driver 1168. The general positions of the shown components relative to the channel 1026 represent the positions of the components prior to the advancement of the firing member (i.e., the pre-fire positions).

**[0101]** FIG. 33 illustrates various embodiments of a surgical instrument 1200. The surgical instrument 1200 includes a handle assembly 1202, an elongated body 1204 connected to the handle assembly 1202, and a disposable loading unit 1010 releasably connected to the elongated body 1204. The disposable loading unit 1010 may be releasably connected to the elongated body 1204 in any manner. For example, the disposable loading unit 1010 may be

releasably connected to the elongated body 1204 via the coupling pegs 1074 described hereinabove. The handle assembly 1202 and the elongated body 1204 may be similar to other handle assemblies and elongated bodies known in the art. For example, the handle assembly 1202 may include means for advancing a firing member that is surrounded by the elongated body 1204 and is utilized to advance the drive block 1172 of the disposable loading unit 1010.

**[0102]** In operation, when the firing member is advanced, the advancement of the firing member causes the drive block 1172 to advance toward the second end 1014 of the disposable loading unit 1010. As the drive block 1172 advances, the knife assembly 1020 advances toward the second end 1014 of the disposable loading unit 1010. The advancement of the knife assembly 1020 causes the anvil pin 1166 to cooperate with the anvil body 1154 to urge the anvil assembly 1024 toward the closed position. The advancement of the knife assembly 1020 also causes the sled 1180 to advance toward the second end 1014 of the disposable loading unit 1010. As the sled 1180 advances, the angled leading edges of the sled 1180 sequentially contact pushers supported within the staple cartridge 1022, causing the pushers to urge surgical fasteners from the staple cartridge 1022 in a known manner.

**[0103]** For embodiments where the first and second medical agent drivers 1168, 1170 are coupled to the knife assembly 1020, the advancement of the drive block 1172 advances the first and second medical agent drivers 1168, 1170 within the first and second sections 1088, 1090 of the body 1086 toward the second end 1084 of the agent cartridge 1018. As the first and second medical agent drivers 1168, 1170 advance, they make contact with the first and second sealing members 1104, 1106 and urge the first and second medical agents out of the first and second dispensing ports 1096, 1102. Because the post-fire positions of the first and second medical agent drivers 1168, 1170 may be some distance from the first and second dispensing ports 1096,

1102, some medical agent may still remain housed by the agent cartridge 1018 after the first and second medical agent drivers 1168, 1170 advance from their pre-fire positions to their post-fire positions.

**[0104]** For embodiments where the first and second medical agent drivers 1168, 1170 are electrically activated polymers, the advancement of the firing member causes an electrical connection to be made with the contact 1174, causing a voltage to be applied to the first and second medical agent drivers 1168, 1170. In response to the applied voltage, the first and second medical agent drivers 1168, 1170 expand within the first and second sections 1088, 1090 of the body 1086 of the agent cartridge 1018 and urge the first and second medical agents out of the first and second dispensing ports 1096, 1102.

**[0105]** With the first projection 1094 and the second projection 1100 serving as stops which restrict the flow of the first and second medical agents along the grooves 1128, 1130 in the direction toward the first end 1012 of the disposable loading unit 1010, the medical agents urged out of the first and second dispensing ports 1096, 1102 advance along the respective grooves 1128, 1130 toward the cutting surface 1114 of the disposable loading unit 1010. As the knife assembly 1020 advances along the slot 1142 defined by the staple cartridge 1022, the staple cartridge 1022 also serves to keep the medical agents in the grooves 1128, 1130 until the medical agents exit the grooves 1128, 1130 proximate the cutting surface 1114. The medical agents are thus effectively delivered to the site of the cutting and stapling.

**[0106]** After a single use, the disposable loading unit 1010 is removed from the elongated body 1204 and may be replaced with another disposable loading unit 1010 for another use. This process may be repeated any number of times. Therefore, the handle assembly 1202 and the elongated body 1204 connected thereto may be reused any number of times.

**[0107]** While several embodiments have been described, it should be apparent, however, that various modifications, alterations and adaptations to those embodiments may occur to persons skilled in the art with the attainment of some or all of the advantages of the various embodiments. For example, according to various embodiments, a single component may be replaced by multiple components, and multiple components may be replaced by a single component, to perform a given function or functions. This application is therefore intended to cover all such modifications, alterations and adaptations without departing from the scope and spirit of the disclosed embodiments as defined by the appended claims.

**[0108]** Any patent, publication, or other disclosure material, in whole or in part, that is said to be incorporated by reference herein is incorporated herein only to the extent that the incorporated material does not conflict with existing definitions, statements, or other disclosure material set forth in this disclosure. As such, and to the extent necessary, the disclosure as explicitly set forth herein supersedes any conflicting material incorporated herein by reference. Any material, or portion thereof, that is said to be incorporated by reference herein, but which conflicts with existing definitions, statements, or other disclosure material set forth herein will only be incorporated to the extent that no conflict arises between that incorporated material and the existing disclosure material.

CLAIMS

What is claimed is:

1. An assembly of a surgical instrument, comprising:  
a housing;  
a cutting member relatively movable with respect to the housing, wherein the cutting member comprises a cutting surface, a body including a first surface, and a groove at least partially defined by the first surface; and  
an agent cartridge connected to the housing, wherein the agent cartridge includes a cavity for housing a medical agent therein, wherein the cutting member groove is in fluid communication with the cavity, and wherein said cutting member movably interacts with said agent cartridge such that movement of said cutting member relative thereto in a first direction causes said medical agent housed within said cavity to be delivered through the groove and dispensed proximate to the cutting surface.
2. The assembly of claim 1, wherein the agent cartridge comprises a body, and wherein the agent cartridge body and the cutting member groove define a passage therebetween for delivering the medical agent from the cavity proximate to the cutting surface.
3. The assembly of claim 1, wherein the agent cartridge includes a dispensing port in fluid communication with the cavity, and wherein the groove remains in fluid communication with the dispensing port as the cutting member is moved relative to the housing.

4. The assembly of claim 1, wherein the surgical instrument comprises a handle and an elongate body extending from the handle, and wherein the housing is releasably connected to the elongate body.
5. The assembly of claim 1, wherein the housing is fixedly connected to a portion of the surgical instrument.
6. The assembly of claim 1, wherein the agent cartridge is directly connected to the housing.
7. The assembly of claim 1, further comprising a staple cartridge connected to the housing.
8. The assembly of claim 1, further comprising a medical agent driver extending from the cutting member, wherein the driver engages the agent cartridge and dispense the medical agent from the agent cartridge cavity to the groove as the cutting member is moved relative to the housing.
9. An assembly of a surgical instrument, comprising:
  - a housing;
  - a member relatively movable with respect to the housing, wherein the member comprises a cutting surface, a body including a first surface, and a passage at least partially defined by the first surface; and
  - an agent cartridge, wherein the agent cartridge includes a medical agent storage portion for housing a medical agent therein, wherein the member passage is in fluid communication with the medical agent storage portion, and wherein said movable member movably interacts with

said medical agent storage portion such that axial movement of said movable member relative thereto in a first direction causes said medical agent housed within said medical agent storage portion to be delivered through the passage to the cutting surface.

10. The assembly of claim 9, wherein the surgical instrument comprises a handle and an elongate body extending from the handle, and wherein the housing is releasably connected to the elongate body.

11. The assembly of claim 9, wherein the housing is fixedly connected to a portion of the surgical instrument.

12. The assembly of claim 9, wherein the agent cartridge includes a dispensing port in fluid communication with the medical agent storage portion, and wherein the passage remains in fluid communication with the dispensing port as the member is moved relative to the housing.

13. The assembly of claim 9, wherein the agent cartridge is directly connected to the housing.

14. The assembly of claim 9, further comprising a staple cartridge connected to the housing.

15. The assembly of claim 9, further comprising a medical agent driver extending from the movable member, wherein the driver engages the agent cartridge and dispense the medical agent from the medical agent storage portion to the passage as the cutting member is moved relative to the housing.

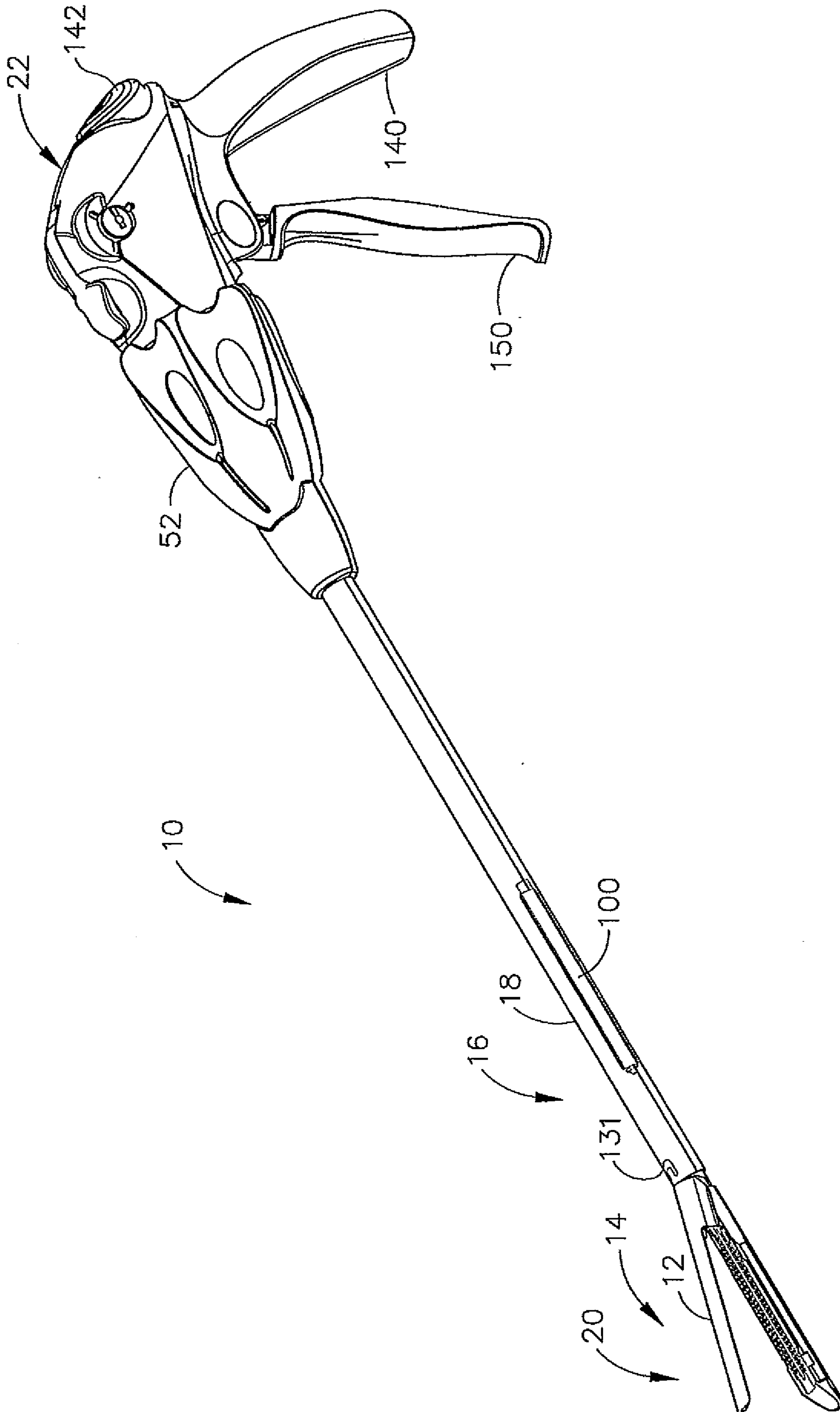

FIG. 1



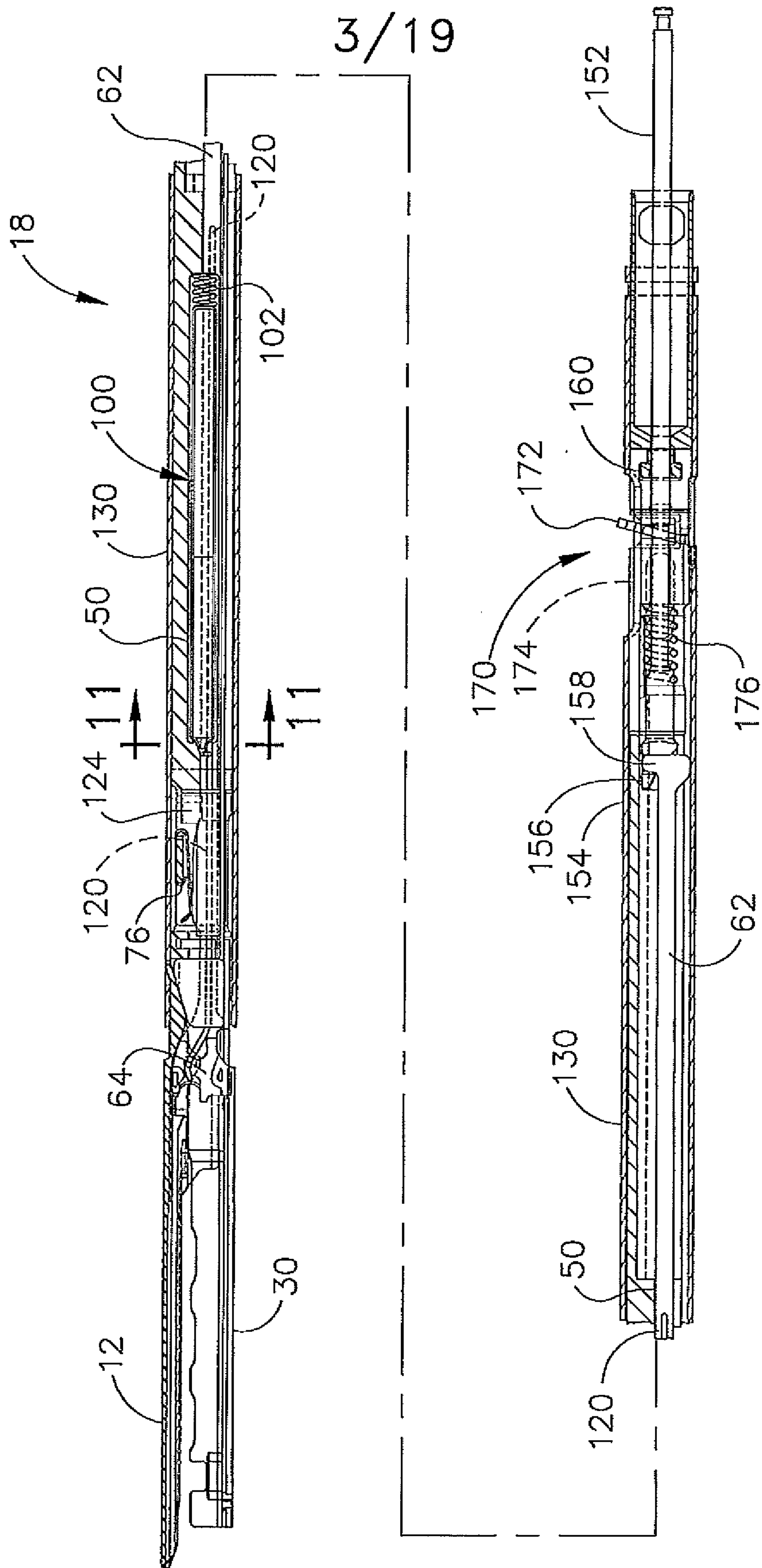

FIG. 3

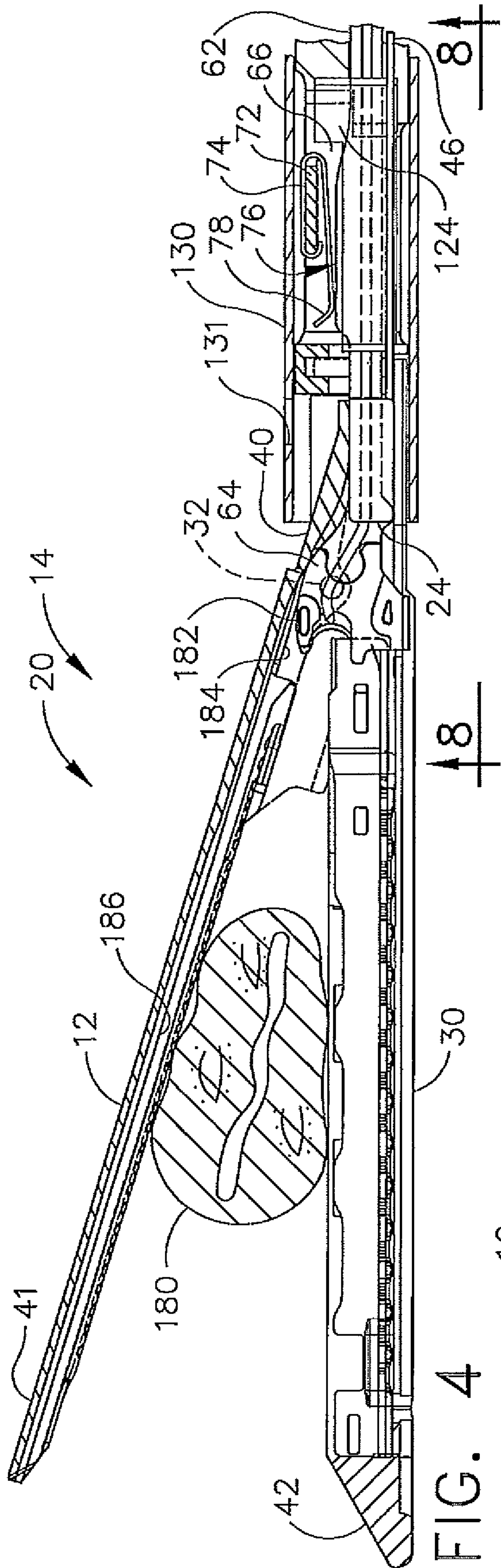

FIG. 4

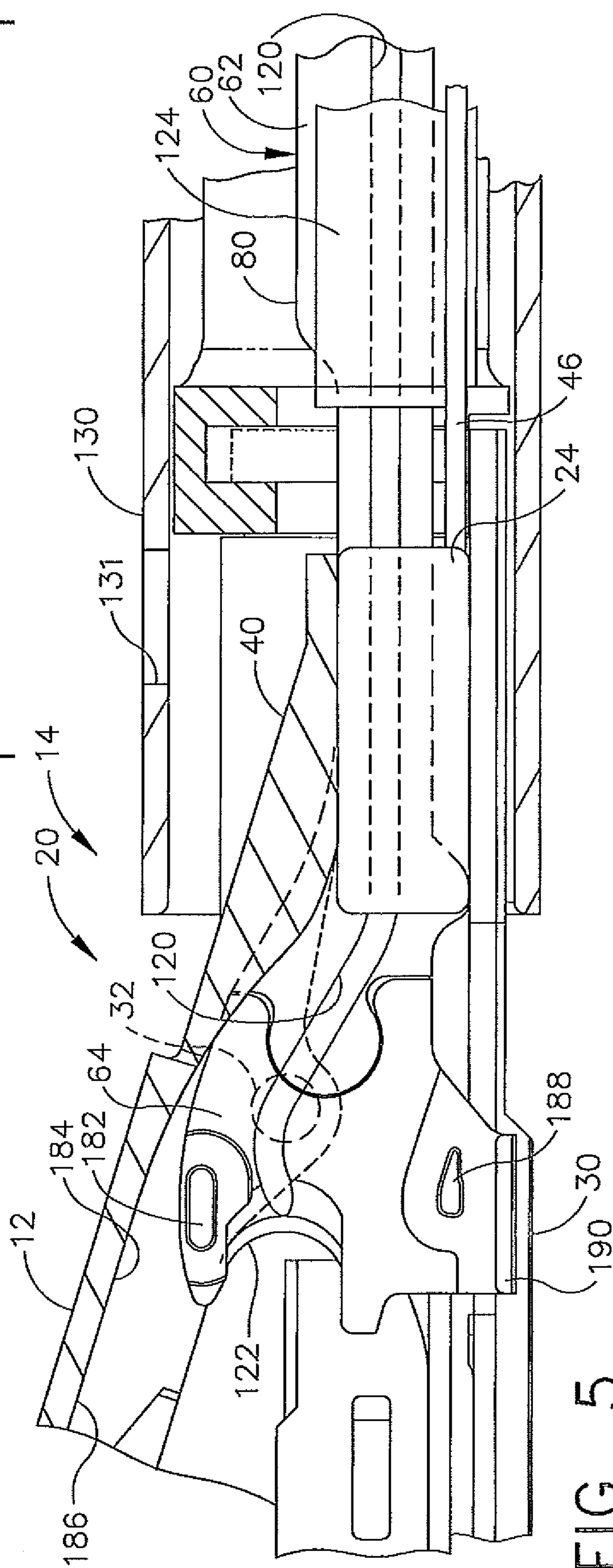

FIG. 5

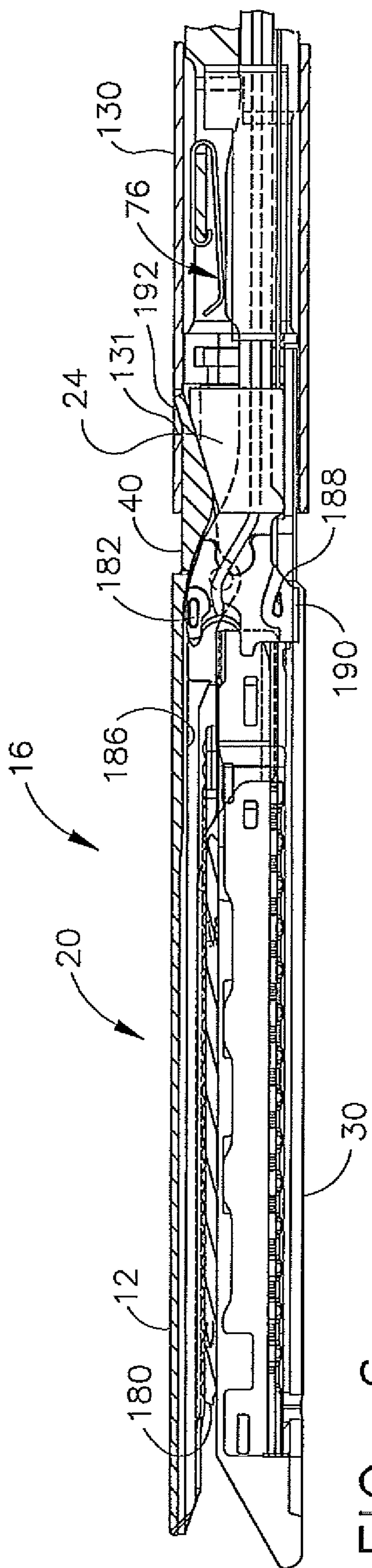

FIG. 6

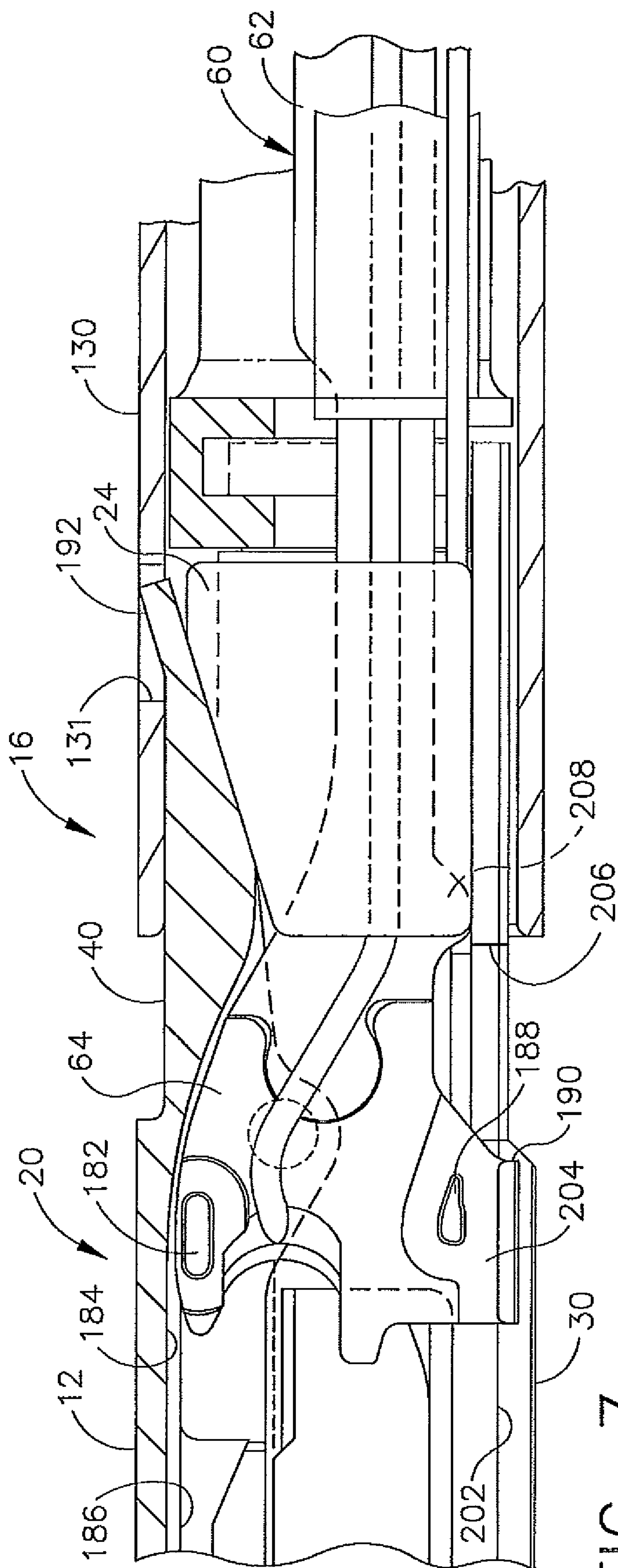

FIG. 7

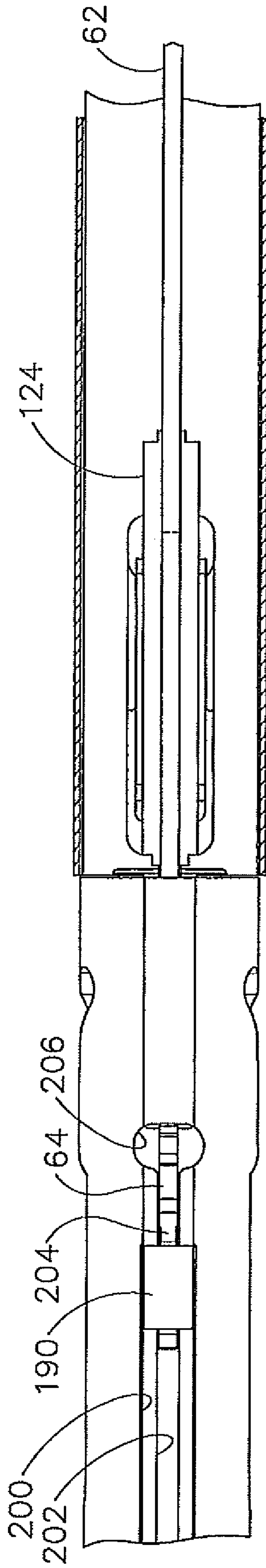

FIG. 8

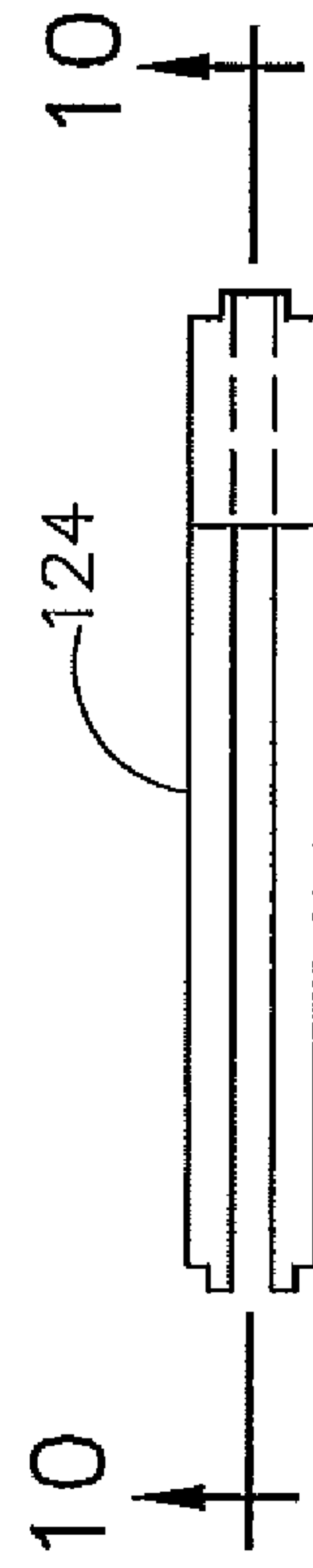

FIG. 9

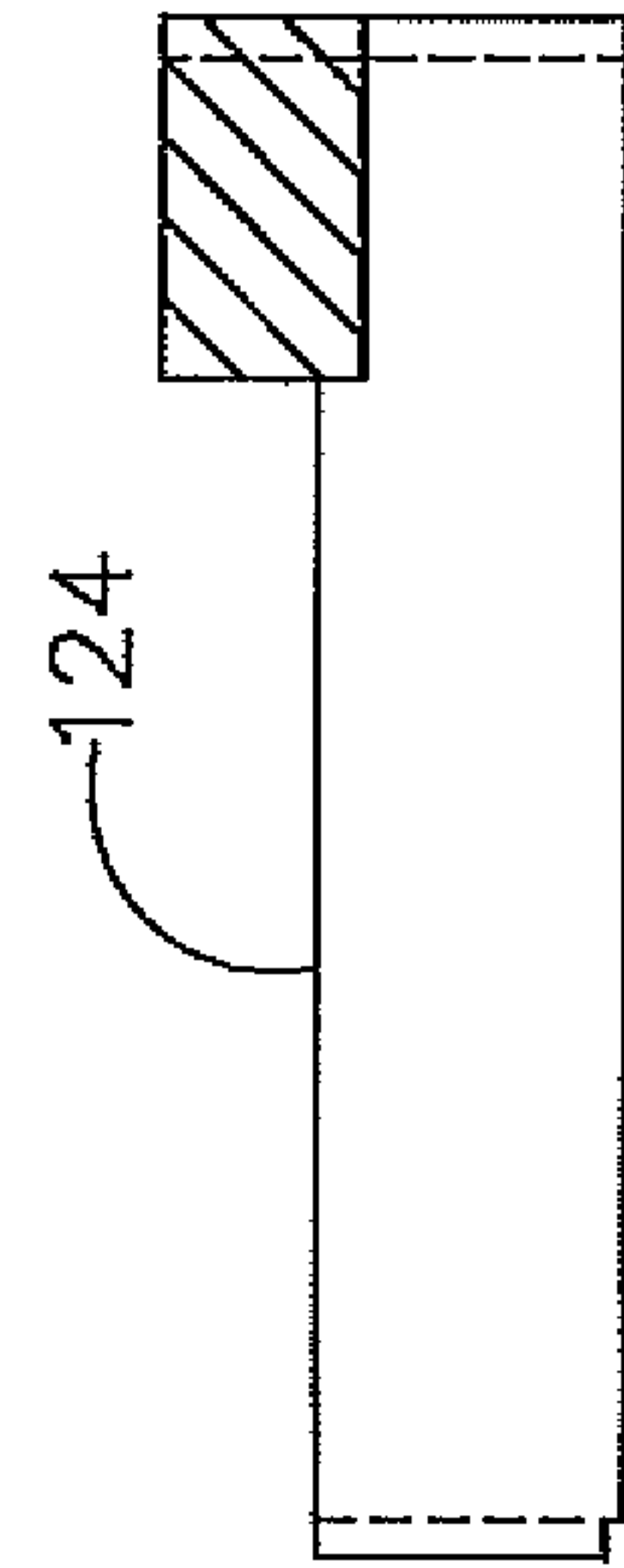

FIG. 10

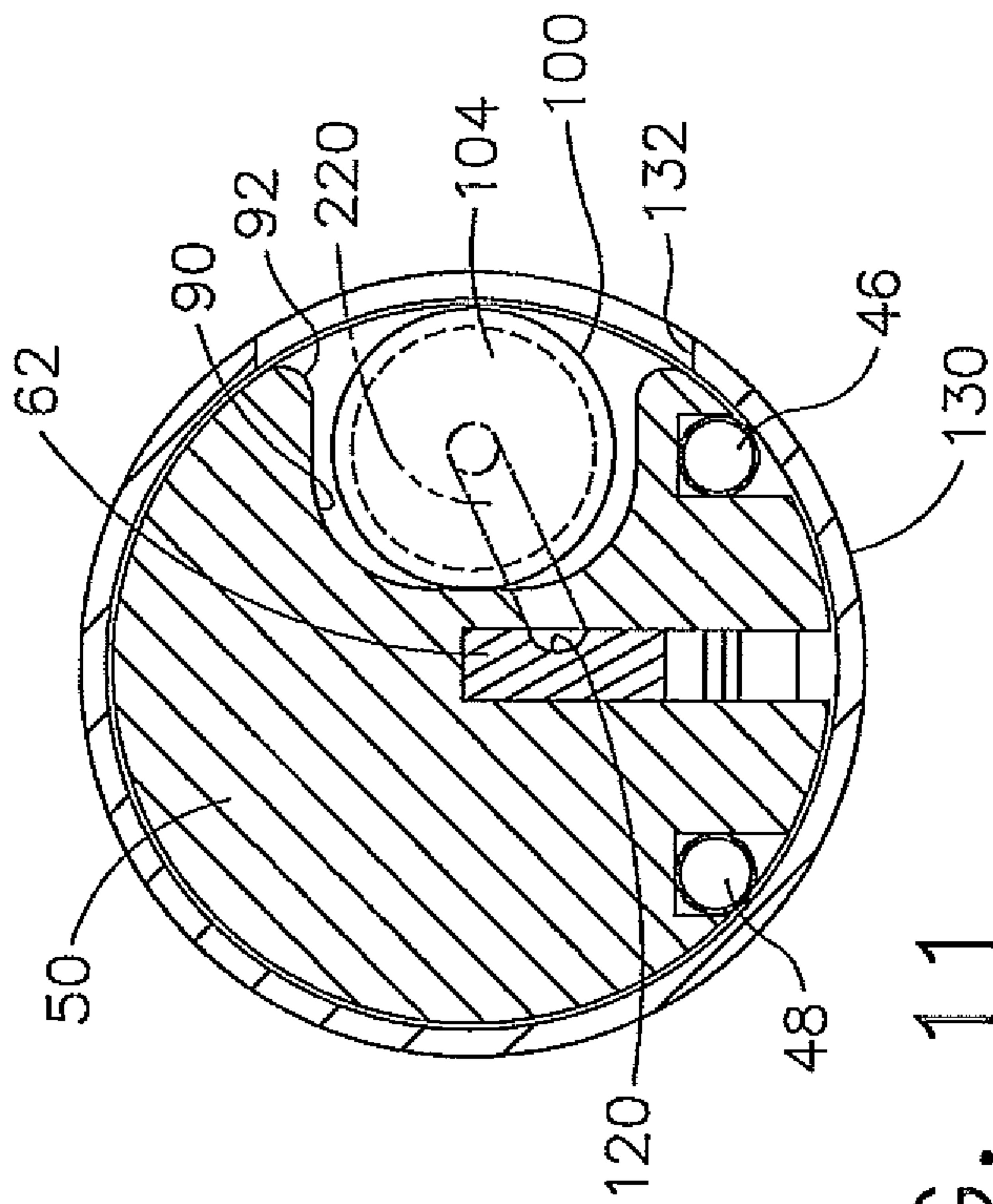

FIG. 11

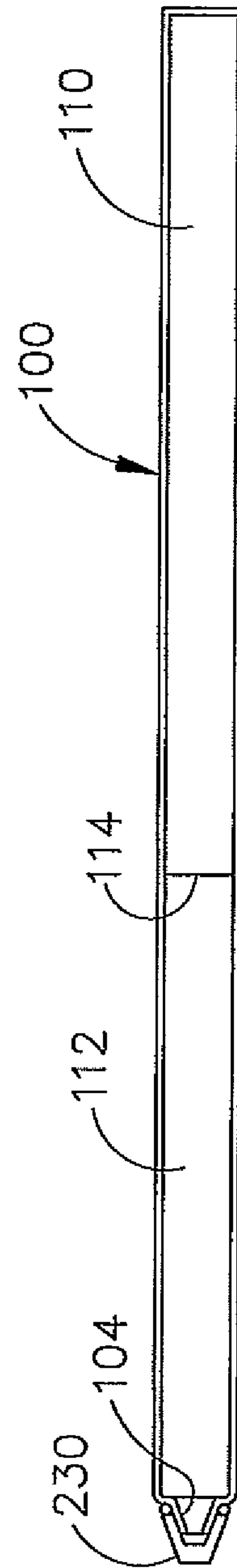

FIG. 12

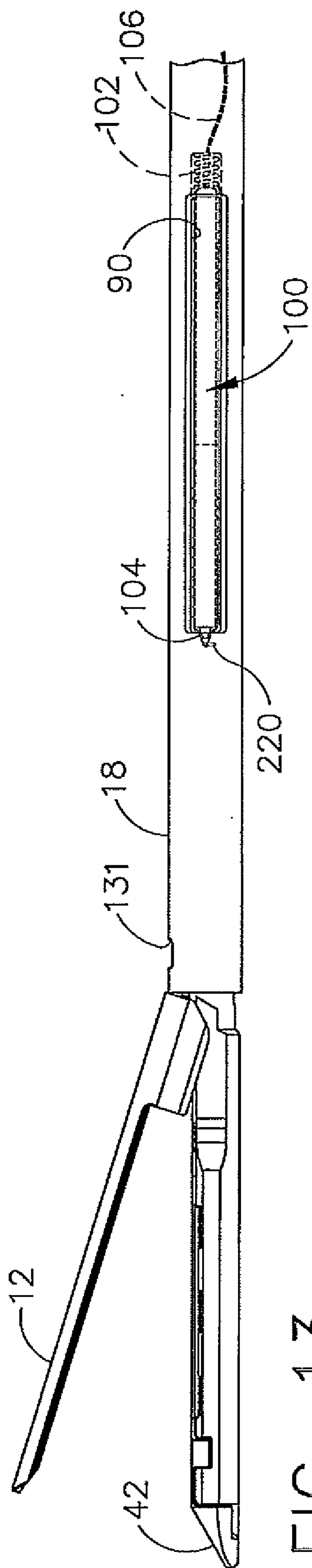

FIG. 13

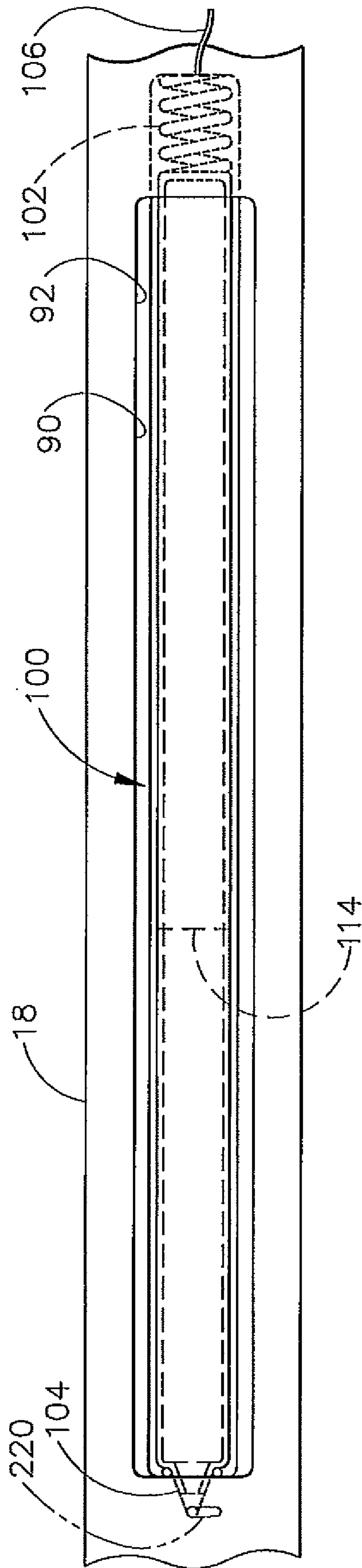

FIG. 14

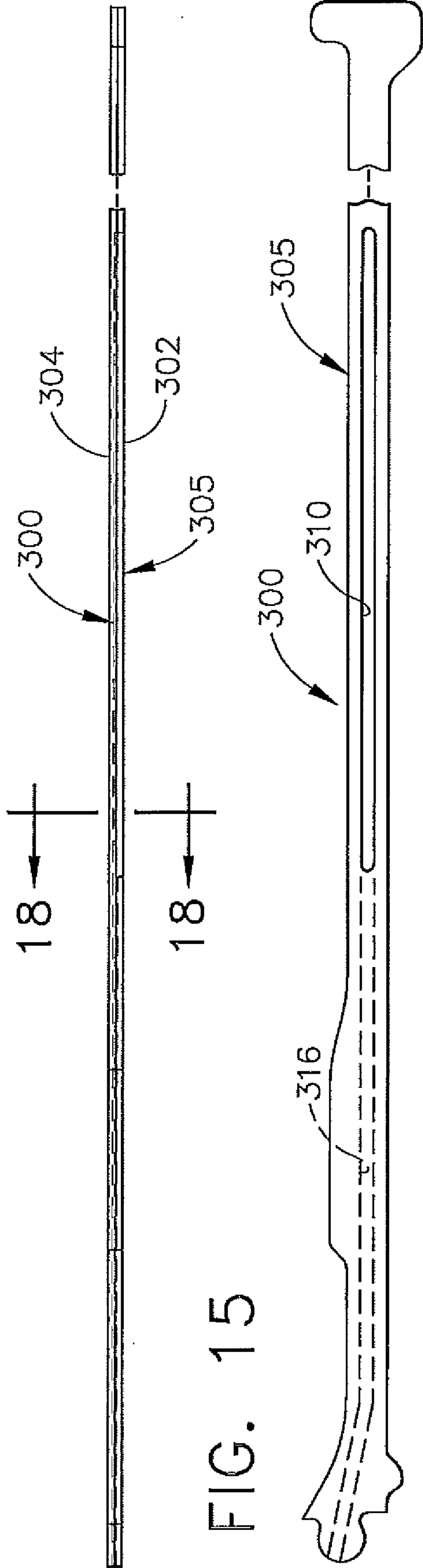

FIG. 15

FIG. 16

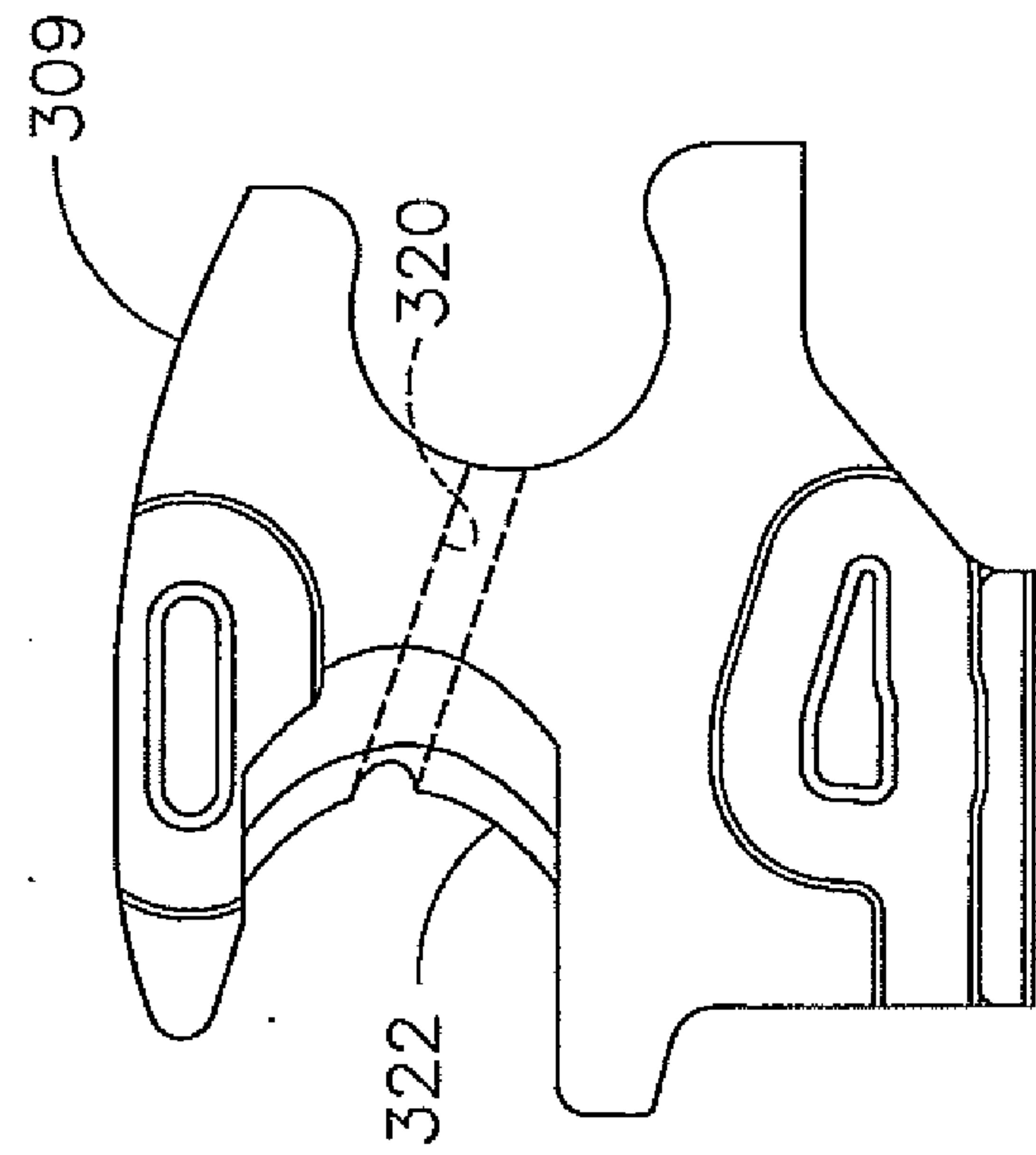

FIG. 17

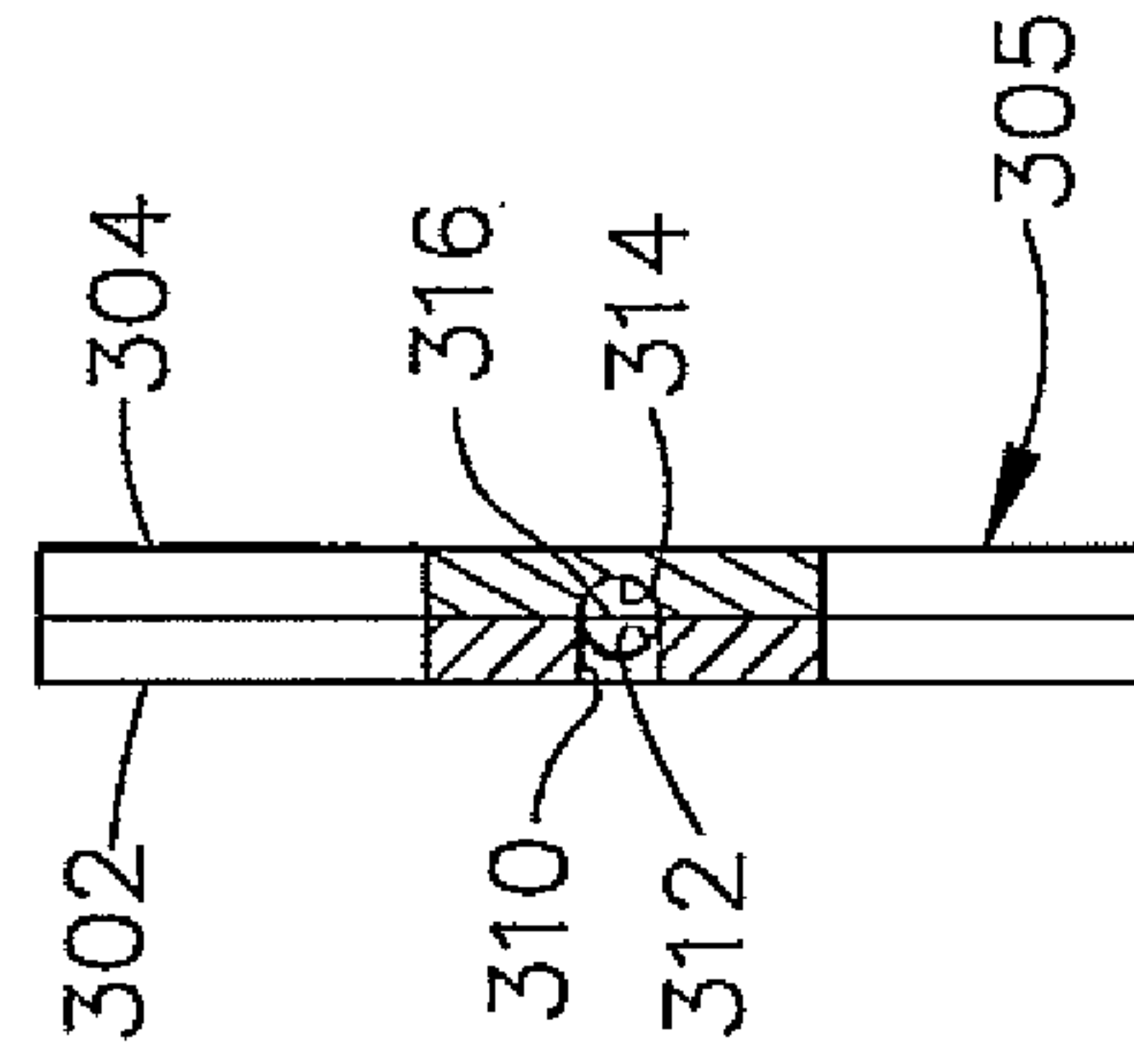

FIG. 18



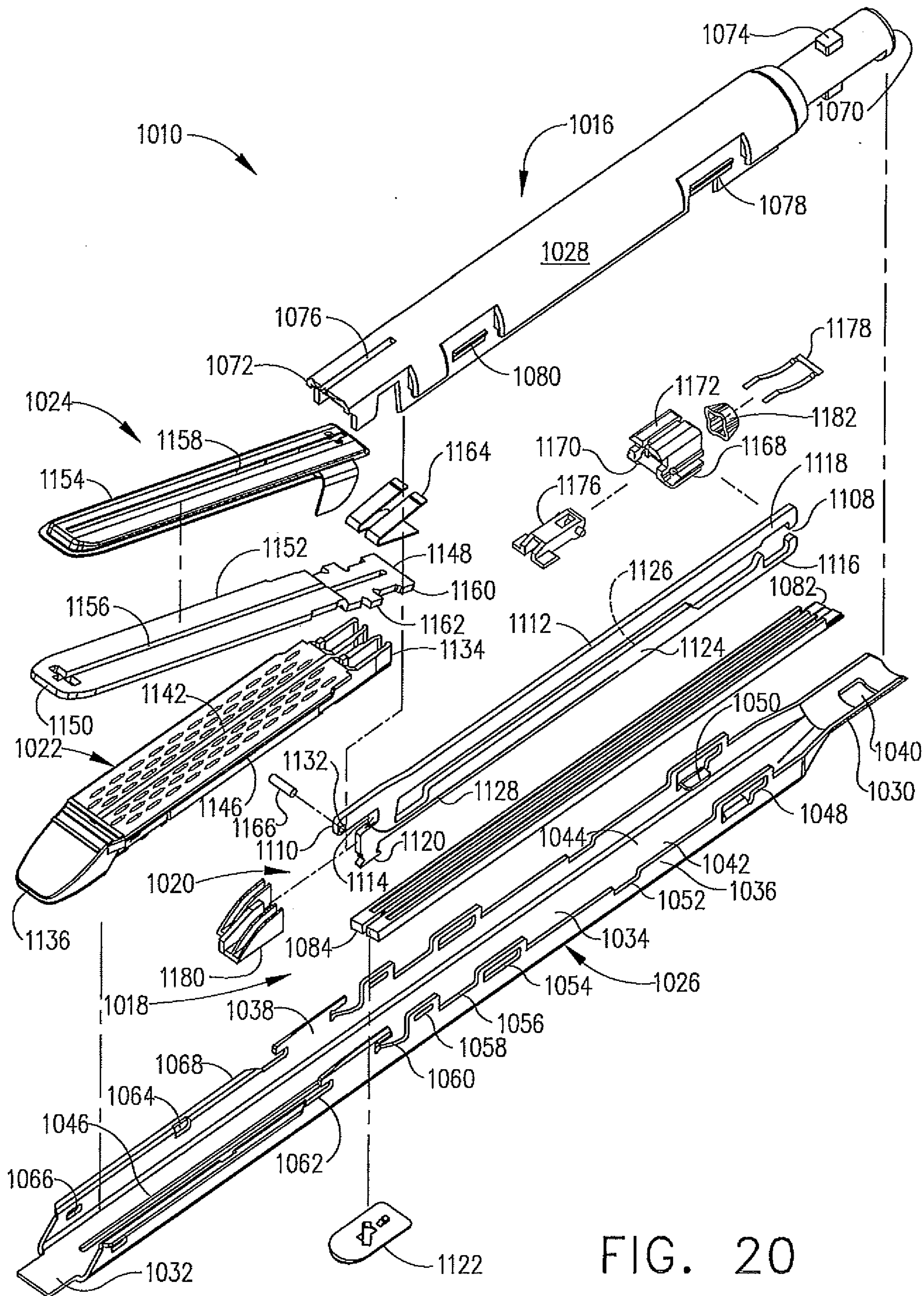

FIG. 20

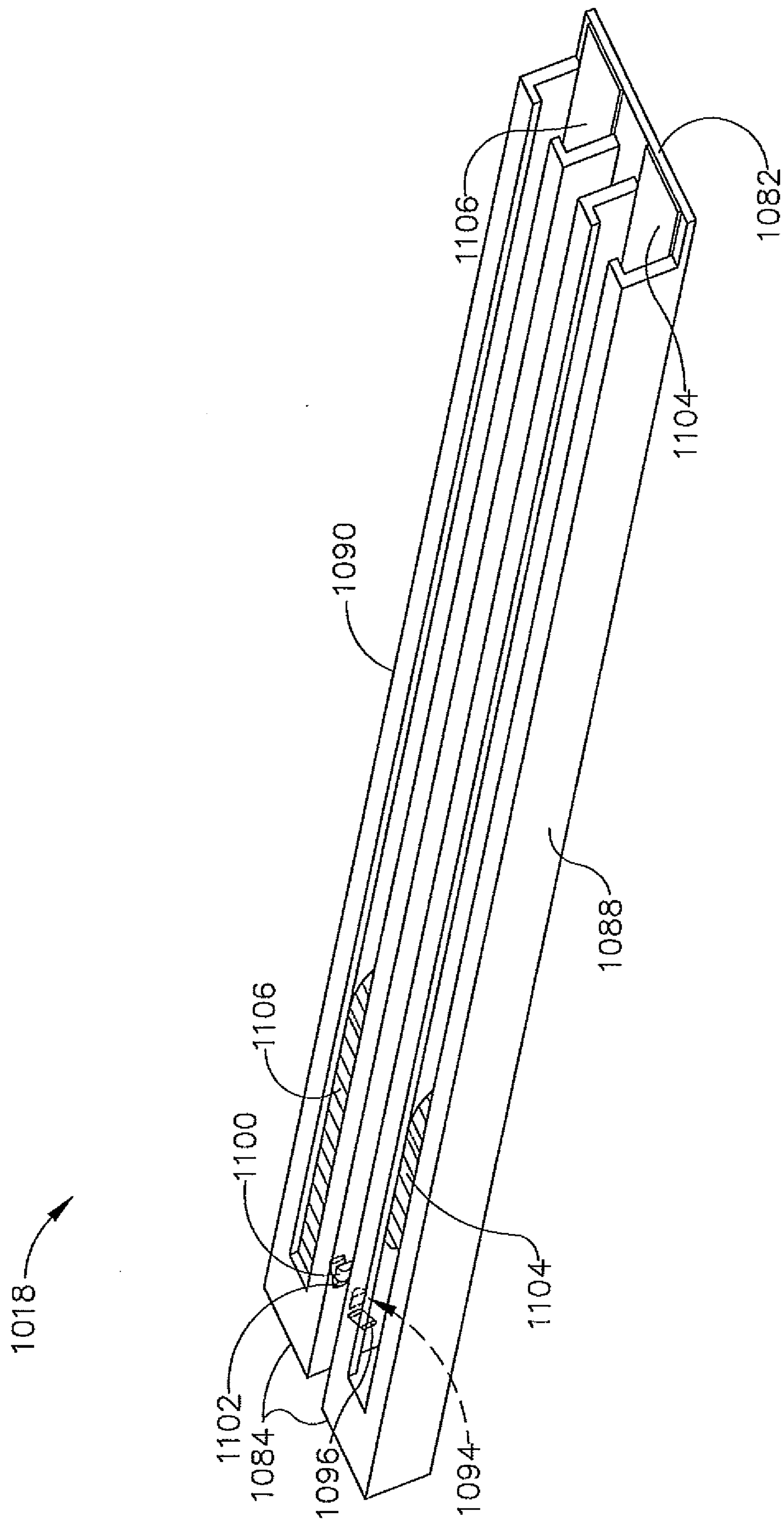

FIG. 21

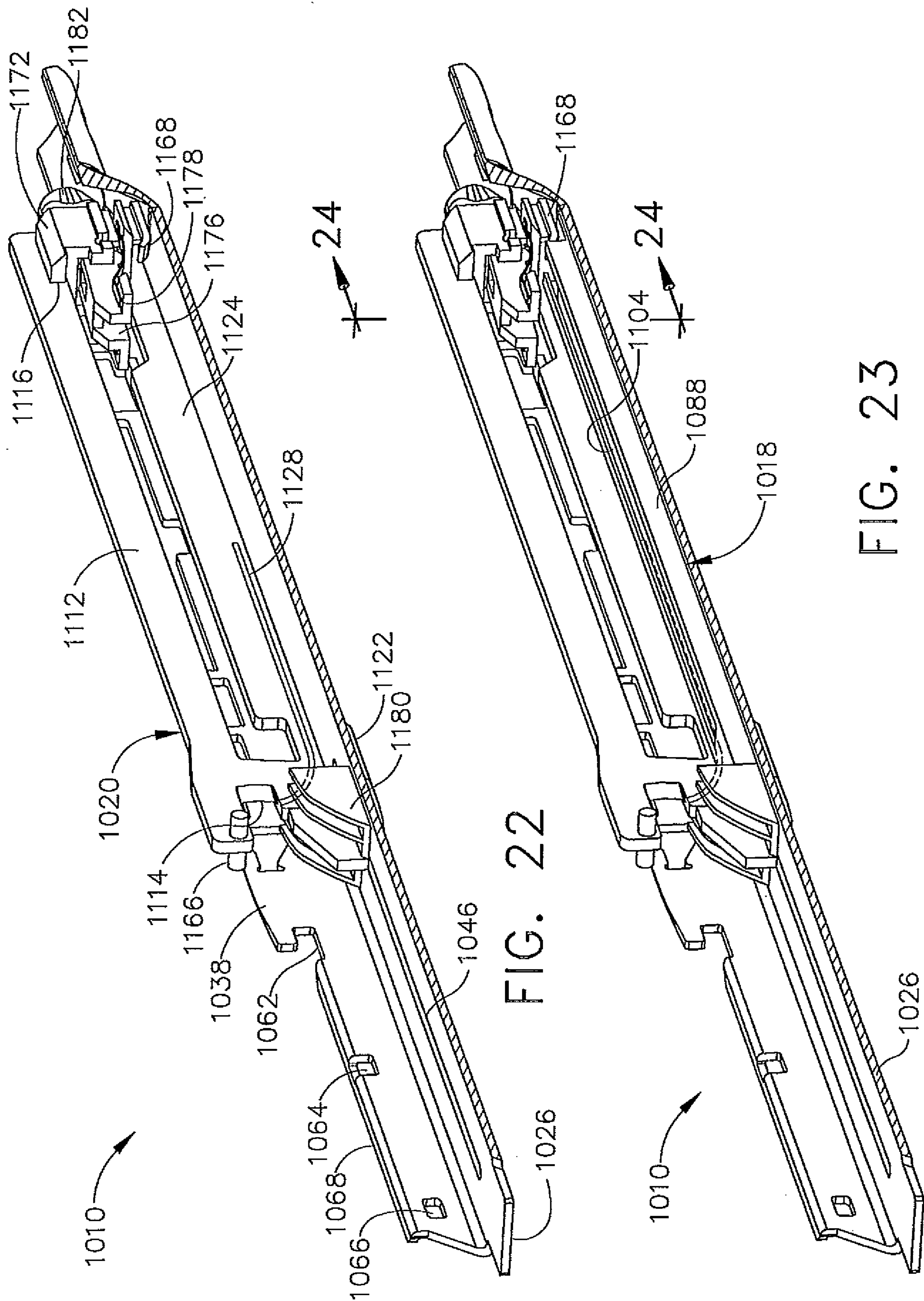

FIG. 22

FIG. 23

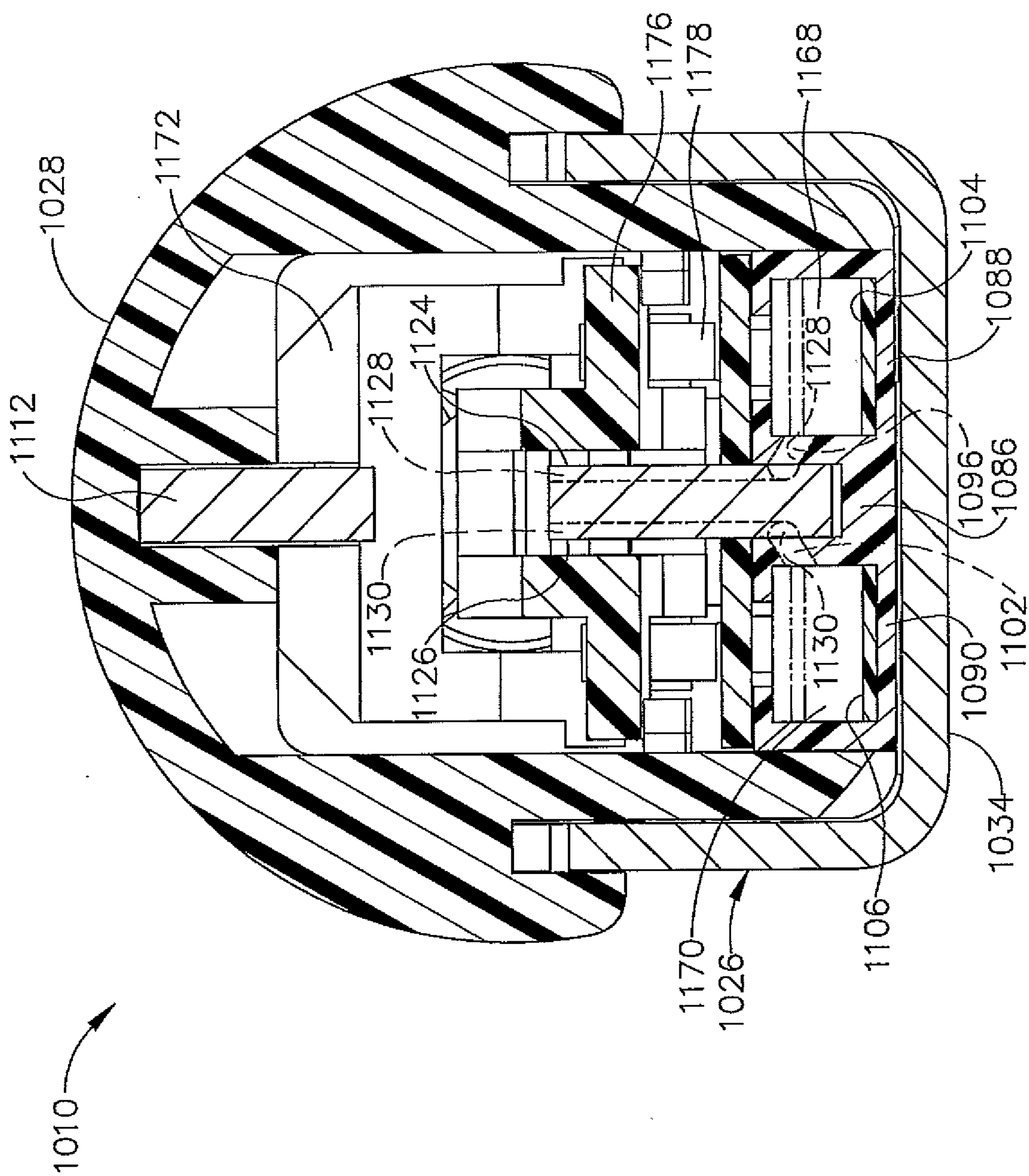

FIG. 24

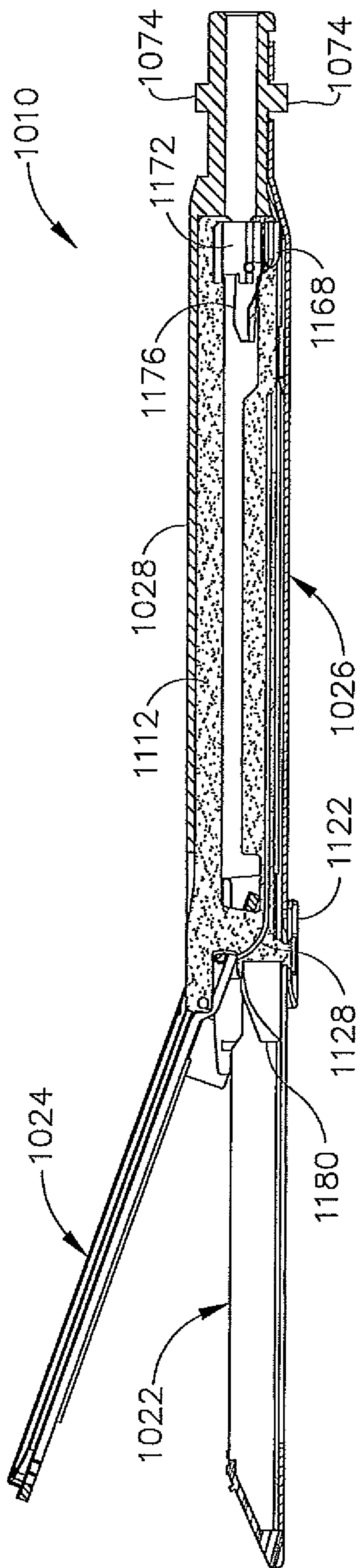

FIG. 25

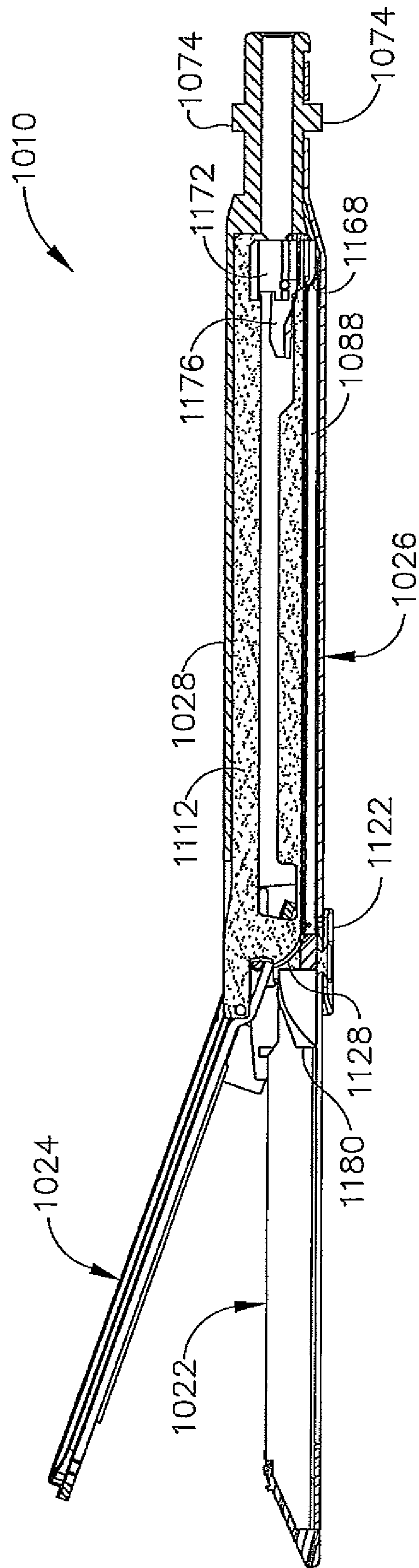

FIG. 26

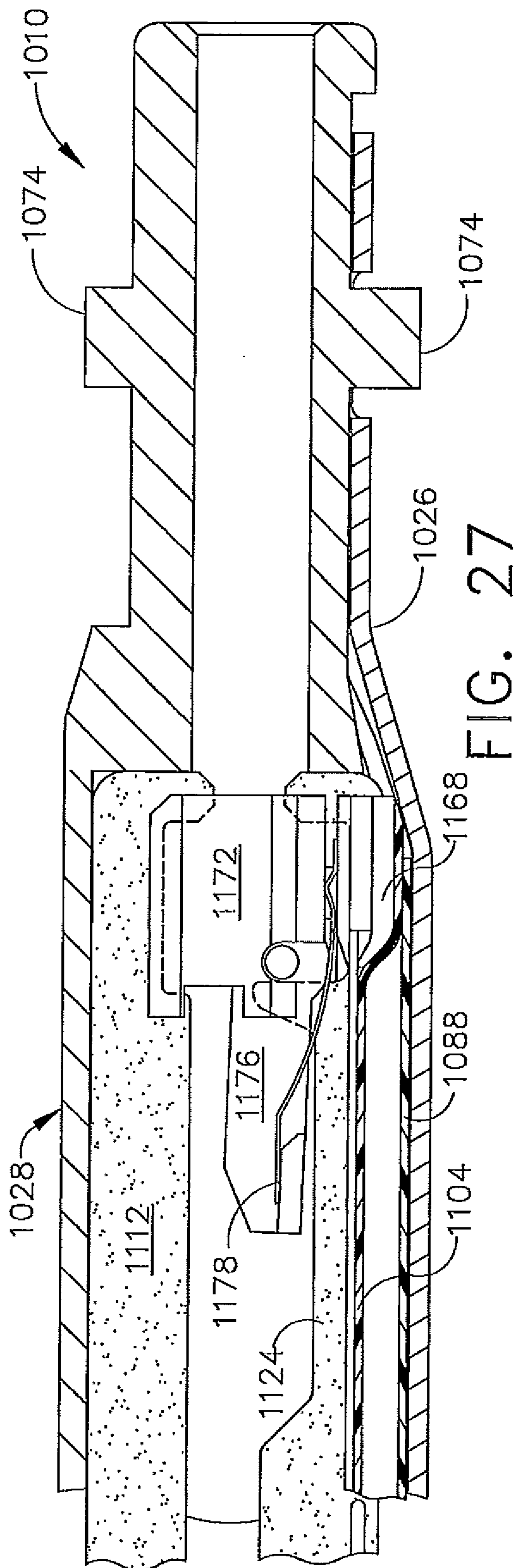

FIG. 27

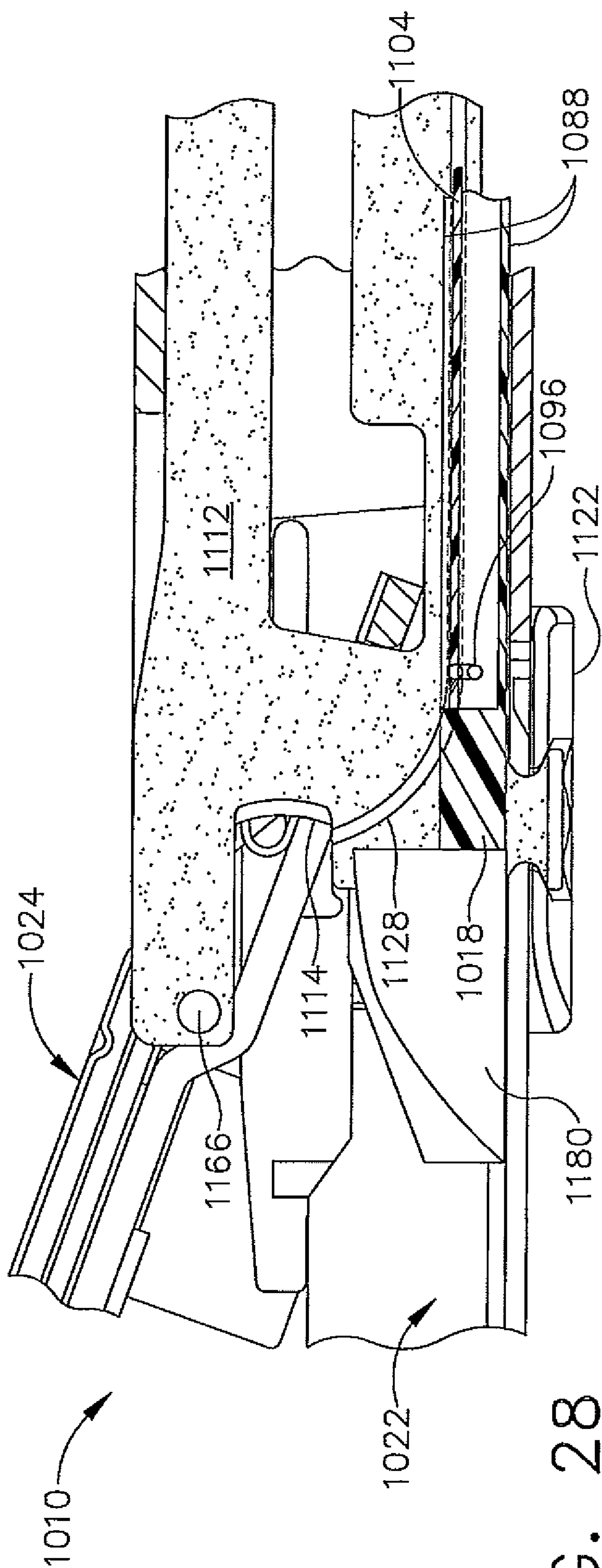

FIG. 28

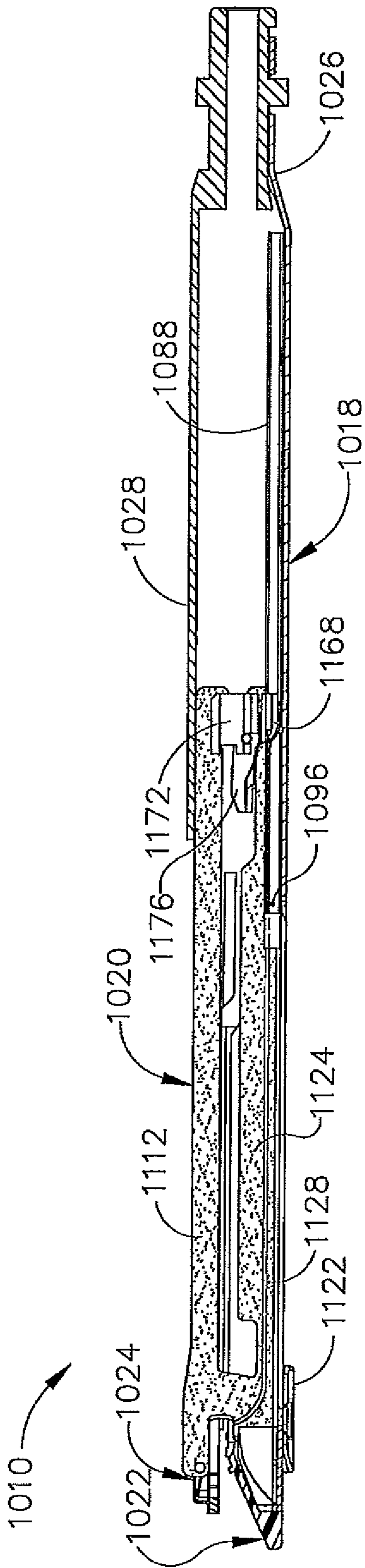

FIG. 29

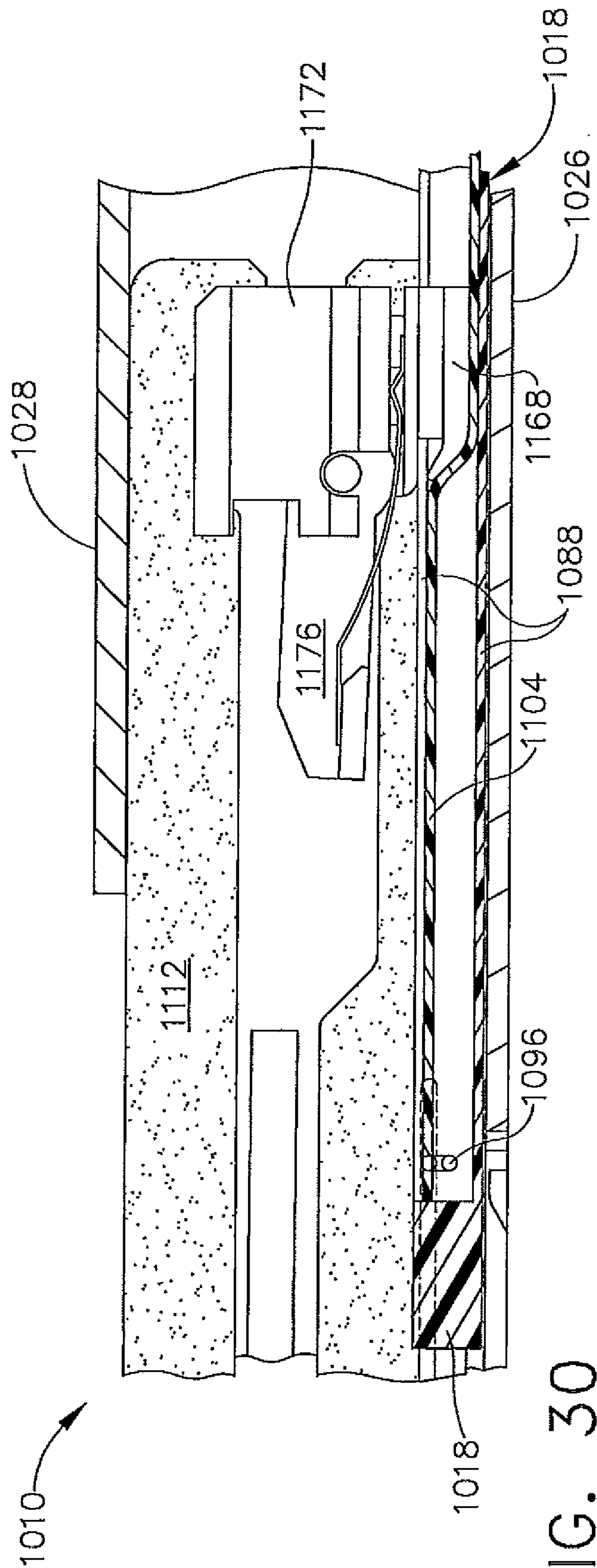

FIG. 30

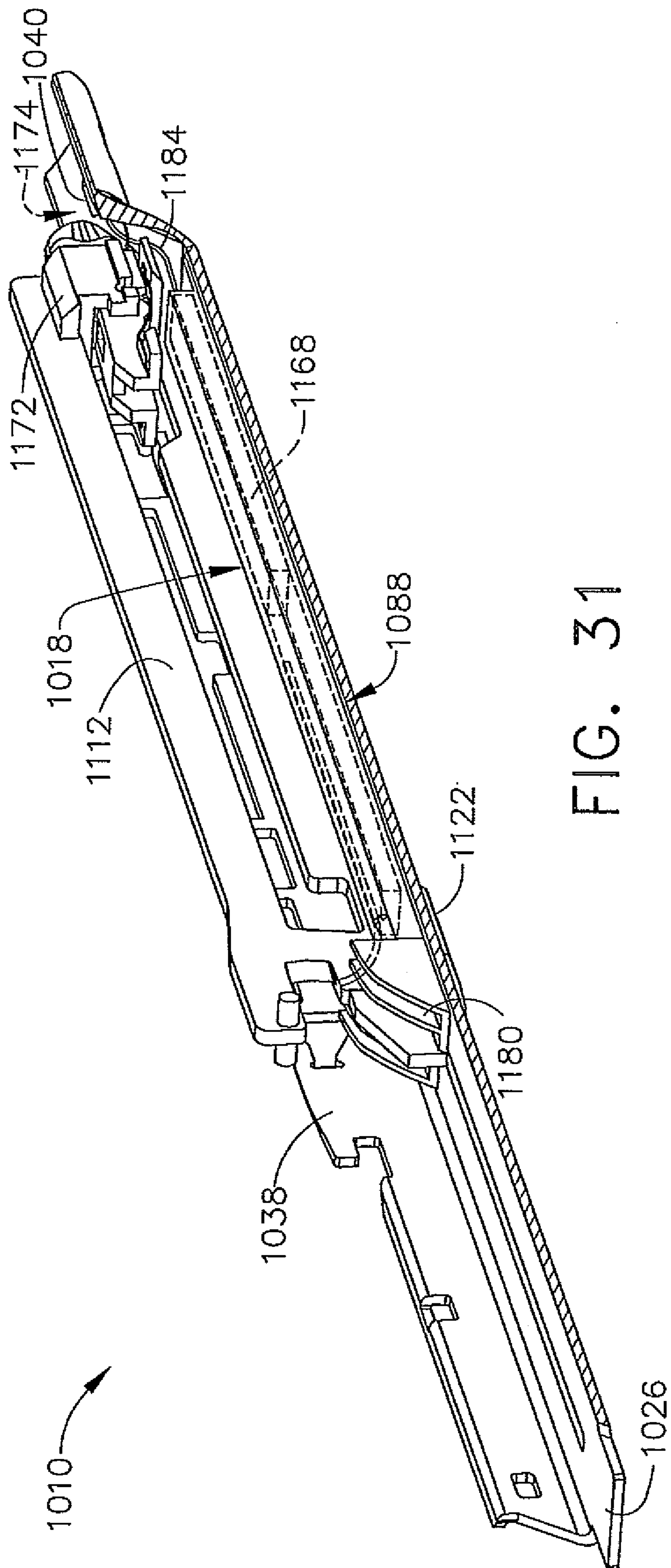

FIG. 31

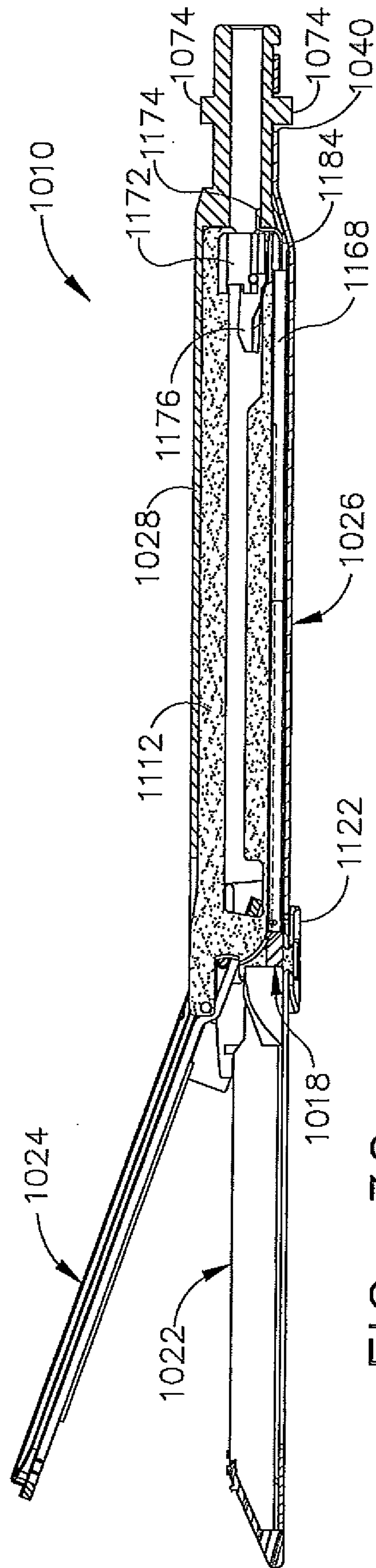

FIG. 32

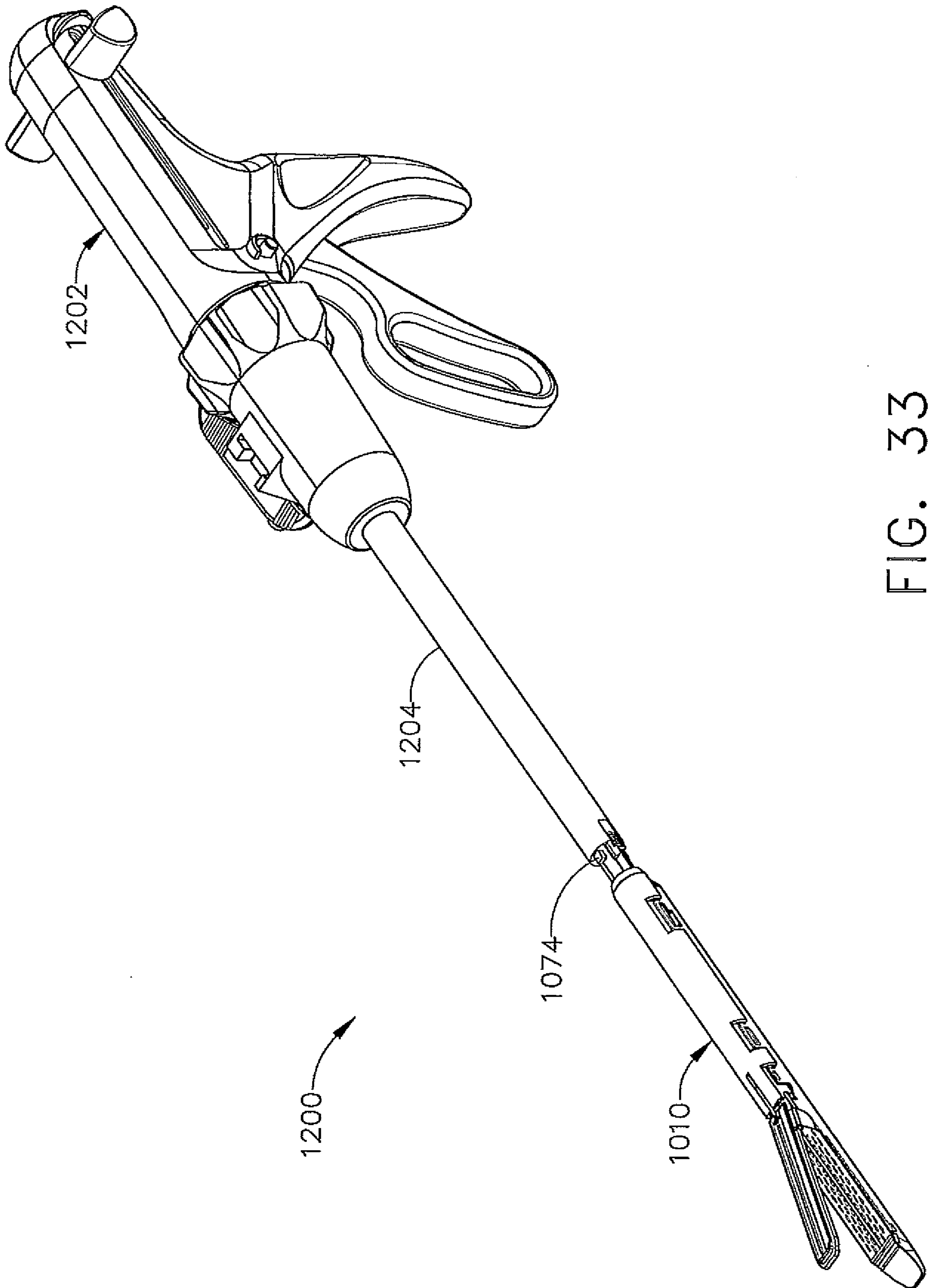

FIG. 33

