

(No Model.)

4 Sheets—Sheet 1.

W. K. LIGGETT. CORN HARVESTER.

No. 521,719.

Patented June 19, 1894.

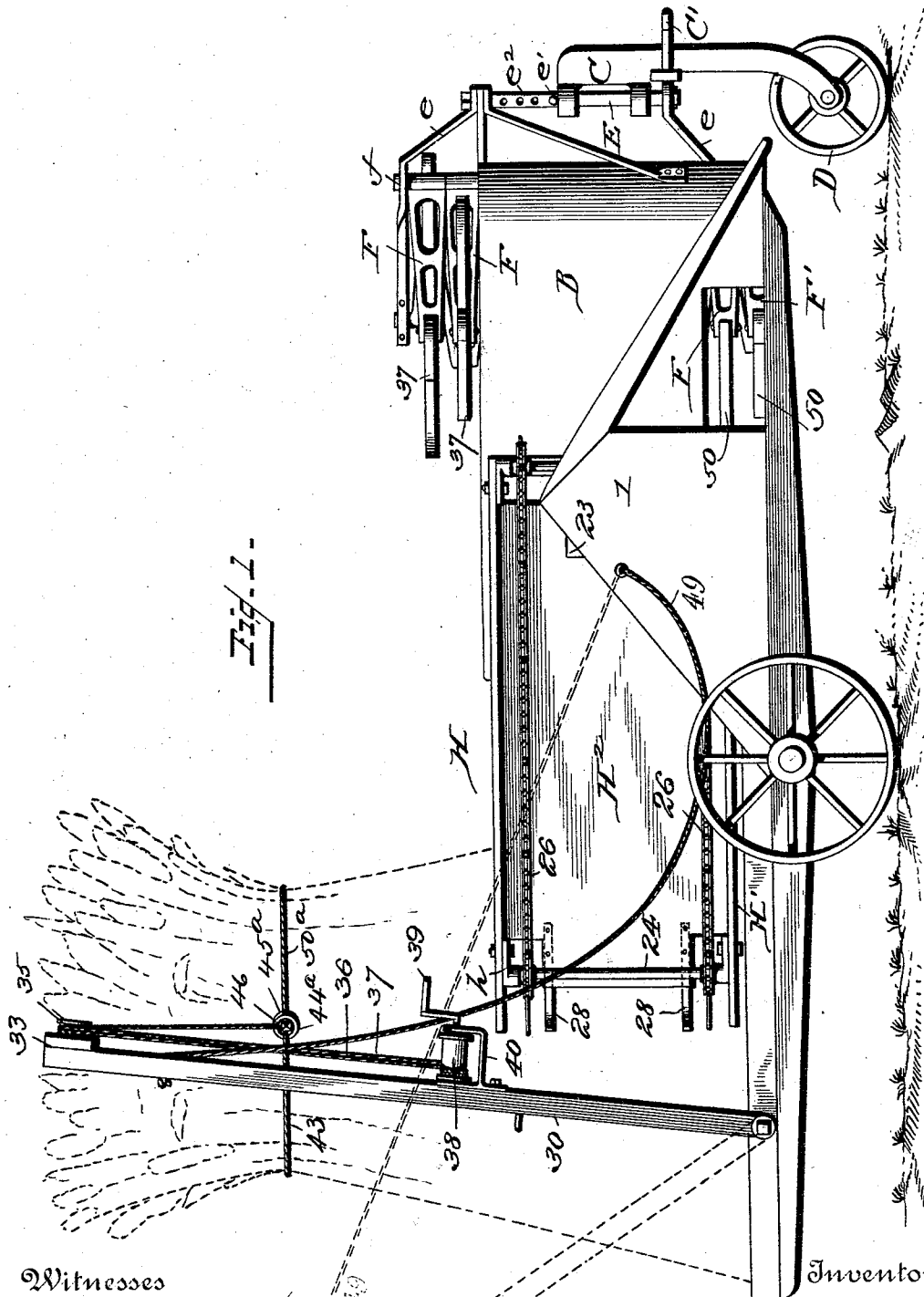

Fig. 1.

Witnesses
Albert Spiden
Van Buren Hillyard

Inventor
William K. Liggett
 By Attorneys *R. A. Placy*

(No Model.)

4 Sheets—Sheet 2.

W. K. LIGGETT. CORN HARVESTER.

No. 521,719.

Patented June 19, 1894.

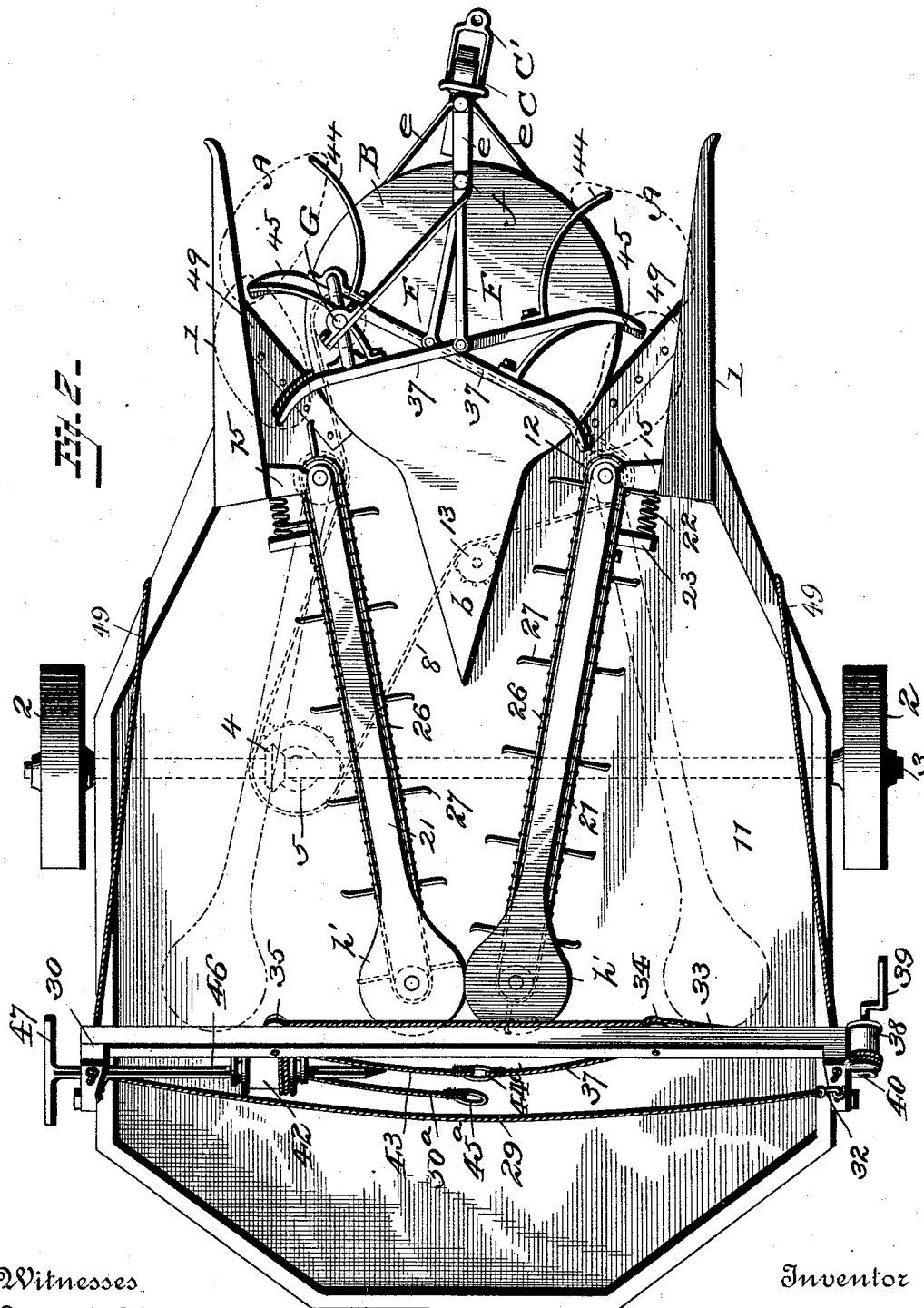

Witnesses

Albert Spiden.
Van Buren Hillyard.

Inventor

William K. Liggett.
By Attorneys *H. A. Lacey*

(No Model.)

4 Sheets—Sheet 3.

W. K. LIGGETT.
CORN HARVESTER.

No. 521,719.

Patented June 19, 1894.

Fig. 4.

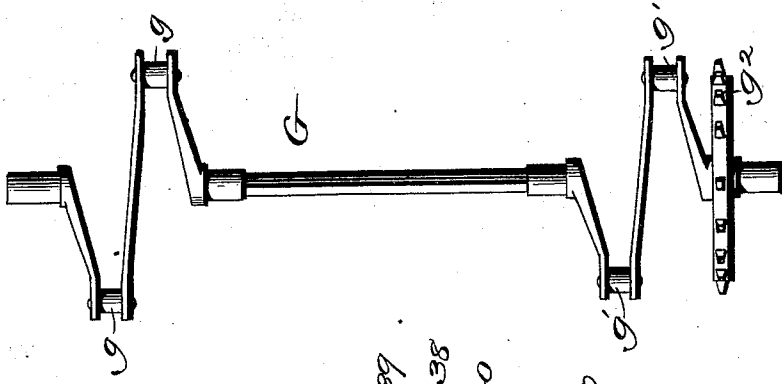
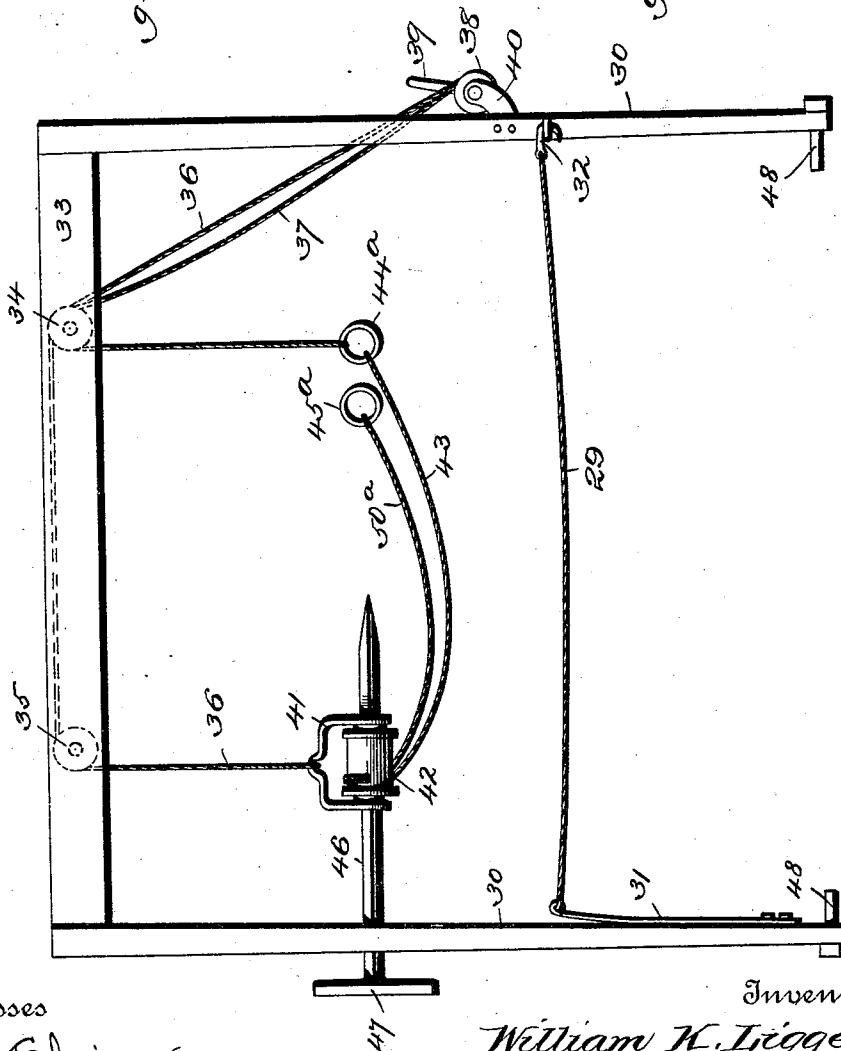

Fig. 5.



Witnesses
Albert Spiden
Van Buren Hillyard.

Inventor
William K. Liggett.
 By Attorneys *R. A. Lacey*

(No Model.)

4 Sheets—Sheet 4.

W. K. LIGGETT.
CORN HARVESTER.

No. 521,719.

Patented June 19, 1894.

FIG. 5.

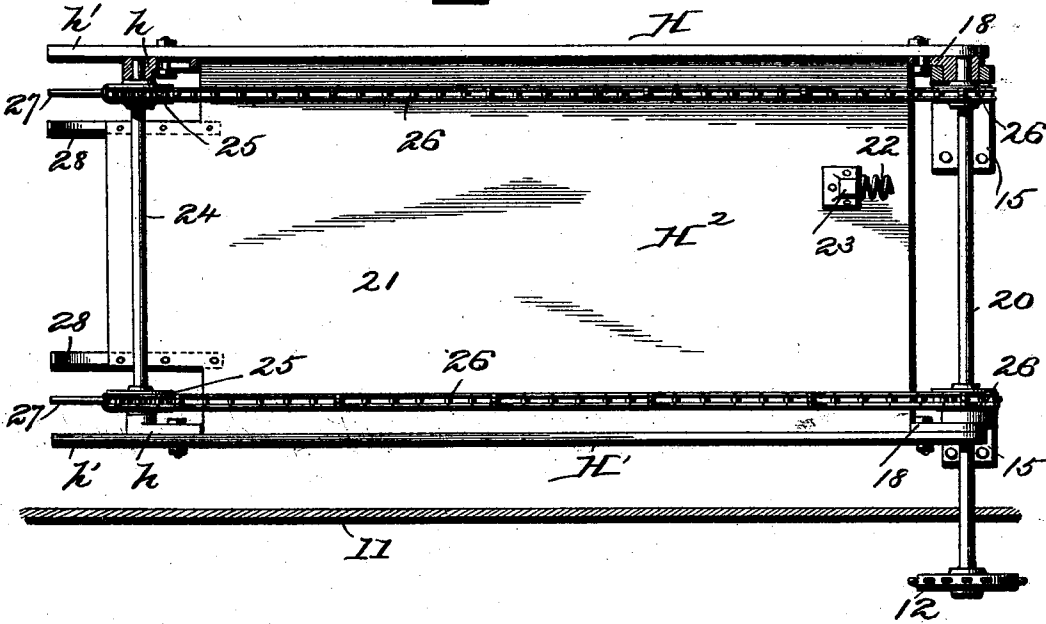

FIG. 6.

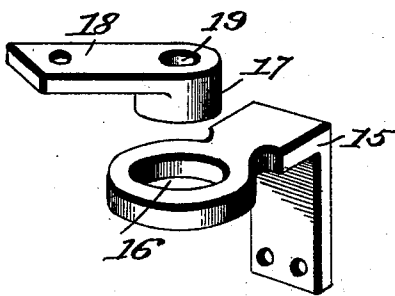

FIG. 7.

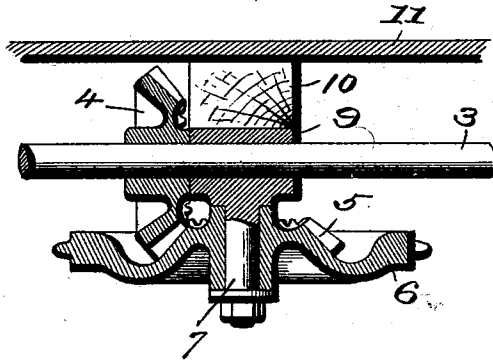
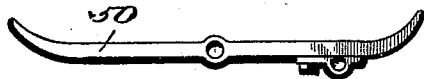

FIG. 8.



Witnesses

Albert Spiden.
Van Buren Hillyard.

Inventor

William K. Liggett.
By Attorneys R. A. Stacey

UNITED STATES PATENT OFFICE.

WILLIAM K. LIGGETT, OF COLUMBUS, OHIO.

CORN-HARVESTER.

SPECIFICATION forming part of Letters Patent No. 521,719, dated June 19, 1894.

Application filed December 12, 1892. Serial No. 454,864. (No model.)

To all whom it may concern:

Be it known that I, WILLIAM K. LIGGETT, a citizen of the United States, residing at Columbus, in the county of Franklin, State of Ohio, have invented certain new and useful Improvements in Corn-Harvesters; and I do hereby declare the following to be a full, clear, and exact description of the invention, such as will enable others skilled in the art to which it appertains to make and use the same.

This invention relates to corn and cane harvesters and is designed as an improvement on the machine for which on August 11, 1892, I filed an application for patent in the United States Patent Office, Serial No. 442,794.

The purpose of the present invention is to produce a machine which will be compact in all its parts, positive in the operation of the active parts, which shall automatically form and pack the shocks, temporarily bind the same and lift the shocks clear of the platform and deposit the same on the ground.

The improvement consists of the novel features and the peculiar construction and combination of the parts which will be herein-after more fully described and claimed and which are shown in the annexed drawings, in which—

Figure 1 is a side elevation of a harvesting machine embodying my invention. Fig. 2 is a top plan view of the machine. Fig. 3 is a detail view of the derrick and the temporary binding appliances. Fig. 4 is an elevation of the crank shaft for actuating the gathering arms. Fig. 5 is an elevation of a carrier for conveying the stalks from the front to the rear end of the platform. Fig. 6 is a detail view of the hinge by means of which the carrier is pivotally connected with the frame of the machine. Fig. 7 is a detail view of the gearing for transmitting motion from the axle to the drive chain. Fig. 8 is a detail view of a lower gathering arm.

The platform 11 is straight from end to end and is arranged to occupy an approximately horizontal position, and has its sides sloping inward at the front end, and is mounted on drive wheels 2 2 placed on the ends of the axle 3 and held thereon in the usual manner common to agricultural machines. This plat-

form is practically balanced upon the axle 3 and is steadied by the caster or pilot wheel D which is journaled in the lower end of the pivoted frame C which is located in front of the machine and is vertically adjustable on a turn post E which is journaled at its ends in suitable brackets or stays *e* projected forward from the plane of the machine. The pivoted frame C is held at the required position on the said post E by means of a pin *e'* passing through one of a series of openings *e*² provided in the upper portion of said turn post. By having the frame C vertically adjustable with reference to the front end of the machine, said front end can be raised or lowered to regulate the height of the cut from the ground as will be readily understood. The pivoted frame C is provided with a clevis C' to which the team is hitched. Rising from the front end of the platform is an approximately cylindrical-shaped frame B having a tapering rear extension *b*, the latter forming passage ways between its sides and the carriers 21 through which the stalks forming the shock pass. The guards 1 located at each side of the platform are approximately triangular in shape and are stationary. These guards flare slightly at their forward ends and form passage ways A A between their inner sides and the opposing sides of cylindrical frame B. The knives 49 extend obliquely across the passage ways A A and may be of any desired pattern. The gathering arms 37 and 50 are pivotally connected midway of their ends to vibrating arms or links F and F', respectively. The upper arms F are pivotally connected at their forward ends to a pin *f*, and the lower arms F' are similarly supported. The upper arms 37 are slightly longer than the lower arms 50 and differ from said lower arms both in form and function. They have double points or tines, the one marked 44 being so placed that it will reach well out in front of the knives, grasp the stalks by being thrust between them, force them back until they will be caught by the tine 45 of the fellow arm when it is withdrawn and moved forward for a new stroke. The path of these arms is shown by the dotted lines in Fig. 2. The lower arms 50 have a single tine, as shown in Fig. 8. The lowest arm shears directly

over the knife 49 and clears it from obstruction. The crank shaft G for imparting motion to the gathering arms, is driven with such a velocity that the lower arm 50 will move backward on the machine with about the same velocity that the machine itself moves forward, thus taking advantage of the inertia of the standing corn to help cut it. By having the arms move rearwardly at the same rate of speed that the machine advances, the knives and arms will simultaneously engage with the corn, the knives on the rear side and the arms on the forward side of the corn holding the latter until cut. Suppose the arms moved to the rear at a faster rate than the forward travel of the machine, the said arms would engage with the corn in advance of the knives and bend it toward the machine. And if the said arms moved at a slower speed, the knives would engage with the corn first and would have a tendency to bend the corn forward, especially would this be the case if the said knives were dull. Hence, it is preferred to have the knives and the arms advance on the corn at the same rate of speed from opposite directions. The upper crank arms *g* of the crank shaft being longer than the lower crank arms *g'* must travel through a greater distance in the same time, the cranks turning together. This is a great help in straightening up down corn, and also that it tends to counteract the tendency of the knives to push the corn forward.

From the foregoing it will be seen that the arms 37 are essentially gathering and packing arms, while the lower arms 50 assist in the cutting of the stalks and bring the butts around in position on the platform. The upper arms 37 should be so disposed that they will act on the stalks near the ears of corn. The lower end of the crank shaft projects below the platform and is provided with a sprocket wheel *g*² around which the drive chain 8 passes. The crank shaft is composed of a coupling rod and an upper and the lower double crank, the upper crank arm *g* being longer than the lower crank arm *g'* for the purpose herein specified.

The axle A is provided near one end with the beveled gear 4 which meshes into and drives a gear wheel 5. This gear wheel 5 is provided on its outer rim with a sprocket gear 6 which engages with and operates the drive chain 8. This combined gear and sprocket wheel is mounted on a pin 7 depending from bearing 9 in which the axle 3 is journaled. This bearing 9 is bolted to a timber 10 supporting the platform 11. The drive chain 8 is located beneath the platform and after passing around the sprocket gear 6, the sprocket wheel *g*², engages the sprocket wheels 12 on the lower ends of vertical shafts 20 which actuate the traveling chains of the carriers 21, and is engaged by an idle sprocket wheel 13 by means of which said drive chain is kept under the required tension.

The carriers 21 are hinged or pivoted at

their front ends to suitable portions of the frame work, which in the present instance are the guards 1 by means of the castings 15 and 18. The casting 15 is bolted to the rear end of the guard 1 and is provided in the horizontal plane with openings 16 to receive the hub portion 17 of the casting 18. This hub 17 is provided with bore 19 to receive the upper end and form a bearing for the shaft 20 which shaft is thus held concentric with the hinge. There will be two sets of castings or hinges for each carrier, as shown most clearly in Fig. 5. The lower end of the shaft 20 extends below the platform 11 and is supplied with a sprocket wheel 12 around which the drive chain 8 passes. A spring 22 interposed between the rear ends of guards 1 and a bracket 23 projected from the carrier, serves to press the rear ends of the carriers together as shown most clearly in Fig. 2, and permits the rear ends of said carriers to separate as the shock is formed and compressed. Each carrier is composed of an upper and lower board H H' respectively, an intermediate plate H² connecting together the two boards H H', shafts 20 and 24 located at opposite ends of the carrier frames, endless chains 26 provided at intervals with hooks or carrying fingers 27 which pass around sprocket wheels 25 and 26 on the shafts 24 and 20, respectively. The shaft 24 is journaled at its ends in brackets *h* which are adjustably connected with the carrier frame so as to be moved to take up any slack in the carrier chains 26. The rear ends of the boards H and H' are expanded for the purpose of automatically disengaging the hooks or fingers 27 from the stalks, as shown most clearly in Fig. 2. Guards 28 secured to the carrier frame conform to the expanded ends of boards H and H' and assists in withdrawing the arms 27 from the stalk. These arms pass between the guards 28 and the expanded portions *h'* of the carrier frame.

A yielding support is provided in the rear of the carriers 21 to support the shock as the same emerges from between the carriers. This yielding support consists of a cord 29 which is provided at one end with the tension device, and at the opposite end with a hook 32 by means of which it may be readily attached to and detached from a suitable stop. The tension device consists of a spring 31 which is fast at one end and has the cord 29 attached to the free end. The supports for the ends of the cord 29 are preferably the standards or side pieces 30 of the derrick. This derrick consists of two standards 30, connected to the frame-work of the platform 11 by the pivots 48, and a top piece 33 rigidly connecting these side pieces. This derrick swings on the pivots 48 and is limited in its backward movement by the cords 49, which connect it with the guards 1. To one of these standards, by means of the bracket 40, is fastened a windlass 38, driven by the crank 39, and on which the ropes 36 and 37 wind.

These ropes pass over the pulleys 34 and 35, and one of them is fixed into the ring 44^a, while the other is fastened to the piece 44, which forms the bearings for the spool 42.

5 On this spool are wound the ropes 43 and 50^a, one of which terminates in the ring 45^a, while the other is fastened to the ring 44^a shown in Figs. 6 and 7. These ropes lead off from the spool in such a manner that they
10 may be simultaneously wound up or unwound. This spool has through it a square hole through which the bar 46 is free to slide. This bar is provided with a handle 47, by means of which it, and consequently, the
15 spool, may be turned.

The action of the mechanism is as follows: The shock having accumulated on the table 11, the bar 46 is thrust through it, the ropes 43 and 50 are brought around the shock, and
20 the rings 44 and 45 are placed over the point of the bar 46, thus forming a band around the shock. This band is then tightened by turning the handle 47, the friction of the various parts being sufficient to hold them from
25 coming loose. The hook 32 is now unsnapped and the shock is lifted by means of the windlass 38, 39 and the ropes 36, 37 after which the derrick swings over to the rear and is stopped by the ropes 49, the shock hanging vertically
30 and clear from the platform, as shown by dotted lines in Fig. 1. The windlass 38, 39 is then released and the shock allowed to fall to the ground, after which the shock is permanently tied and the bar 46 is withdrawn.
35 This releases the rings 44 and 45 and consequently the band around the shock. The rope 29 is then hooked up and the machine proceeds until another shock has accumulated.

40 Having thus described my invention, what I claim, and desire to secure by Letters Patent, is—

1. In a corn harvester the combination of gathering arms pivotally connected midway of their ends to vibrating arms, and having
45 double tines at each end, and means for actuating said gathering arms, substantially as set forth.

2. In a corn harvester the combination with
50 upper and lower gathering arms connected midway of their ends to vibrating arms, of a crank shaft having a double crank at each end, and having the crank arms of the upper crank longer than the crank arms of the lower
55 crank, and means for actuating said crank shaft, substantially as described.

3. In a corn harvester, the combination of upper and lower gathering arms, the lower gathering arms having a single tine and the
60 upper gathering arms having double tines the crank shaft having an upper and lower double crank, the crank arms of the upper crank being longer than the crank arms of the lower crank, and means for actuating
65 said crank shaft, substantially as and for the purpose set forth.

4. In a corn harvester the combination with the platform having guards 1 projected forwardly therefrom, and having the approximately cylindrical shaped frame B projected
70 vertically therefrom and forming passages between its sides and the opposing sides of the guards, of gathering arms connected midway of their ends to vibrating arms and adapted to have their ends work beyond
75 the opposite sides of the frame B, to carry the stalks through the said passages in a positive manner, and a single crank shaft for actuating the said gathering arms, substantially as set forth. 80

5. In a corn harvester, the combination with the cutting and gathering mechanism, of two carriers pivotally connected with the frame of the machine and held together at their rear ends, so as to yield and separate under a
85 certain lateral pressure substantially as set forth.

6. In a corn harvester the combination with the cutting and gathering mechanism, of two carriers pivotally supported at their forward
90 ends and yieldingly held together at their rear ends, and yielding support in the rear of said carriers to support the shock during the formation of the same, substantially as set forth. 95

7. In a corn harvester the combination with cutting and gathering mechanism of two carriers comprising a frame which is pivotally supported at its front end, and having the rear end expanded, and an endless conveyer
100 provided with fingers, which latter are disengaged from the stalk by the expanded end of the carrier frame, and springs for pressing the rear ends of the carriers together, substantially as set forth. 105

8. In a corn harvester, the combination with the cutting and gathering mechanism, of two carrier frames pivotally supported at their forward ends, and having guards at their rear
110 ends, a shaft at the forward end of each carrier concentric with the axes about which the carrier frames turn, an endless conveyer supported by shafts at each end of the carrier frames and springs for pressing the rear ends
115 of the carrier frames yieldingly together, substantially as set forth.

9. In a corn harvester, the combination with the cutting, gathering and shock forming mechanism, of a swinging derrick, a temporary binder, consisting of a spool mounted in
120 a frame, cords connected with said spool and having rings, and a bar passing through said spool and adapted to be thrust through the shock and receive said rings on its projecting ends, and an elevating appliance attached
125 to said temporary binder, consisting of a windlass and cord the latter being attached to the spool frame and one of the rings, respectively, substantially as herein specified.

10. In a corn harvester, the combination of
130 guards 1 projected forwardly from the platform, an approximately cylindrical shaped

frame B rising from the platform and forming passages A and having a rear tapering extension, two carriers pivotally supported at their forward ends and having guards at their rear ends, springs for yieldingly pressing together the rear ends of said carriers, a yielding support arranged in the rear of the carriers, and a swinging derrick provided with a temporary binder and shock elevating de-

vices, substantially as described for the purpose set forth.

In testimony whereof I affix my signature in presence of two witnesses.

WILLIAM K. LIGGETT.

Witnesses:

JOHN CROWE,
ISOM FINLEY.