



(51) International Patent Classification:

A61B 18/12 (2006.01) A61B 17/42 (2006.01)
A61B 17/34 (2006.01) A61M 31/00 (2006.01)
A61M 3/04 (2006.01)

(21) International Application Number:

PCT/US2012/063406

(22) International Filing Date:

2 November 2012 (02.11.2012)

(25) Filing Language:

English

(26) Publication Language:

English

(30) Priority Data:

61/555,655 4 November 2011 (04.11.2011) US

(71) Applicant (for all designated States except US):

ARQOS SURGICAL, INC. [US/US]; 20195 Stevens Creek Blvd, #120, Cupertino, CA 95014-2380 (US).

(72) Inventors; and

(71) Applicants (for US only): **GERMAIN, Aaron** [US/US]; 3563 S. Bascom Road, Apt. 2, Campbell, CA 95008 (US). **KLEIN, Kyle** [US/US]; 816 Sevin Terrace, San Jose, CA 95133 (US). **WALKER, Michael, D.** [US/US]; 414 Shrader Street, San Francisco, CA 94117 (US). **TRUCKAI, Csaba** [US/US]; 19566 Arden Court, Saratoga, CA 95070 (US). **SHADDUCK, John, H.**

[US/US]; 20195 Stevens Creek Blvd., #120, Cupertino, CA 95014-2380 (US).

(74) Agents: **HESLIN, James, M.** et al.; Wilson Sonsini Goodrich & Rosati, 650 Page Mill Road, Palo Alto, CA 94304-1050 (US).

(81) Designated States (unless otherwise indicated, for every kind of national protection available): AE, AG, AL, AM, AO, AT, AU, AZ, BA, BB, BG, BH, BN, BR, BW, BY, BZ, CA, CH, CL, CN, CO, CR, CU, CZ, DE, DK, DM, DO, DZ, EC, EE, EG, ES, FI, GB, GD, GE, GH, GM, GT, HN, HR, HU, ID, IL, IN, IS, JP, KE, KG, KM, KN, KP, KR, KZ, LA, LC, LK, LR, LS, LT, LU, LY, MA, MD, ME, MG, MK, MN, MW, MX, MY, MZ, NA, NG, NI, NO, NZ, OM, PA, PE, PG, PH, PL, PT, QA, RO, RS, RU, RW, SC, SD, SE, SG, SK, SL, SM, ST, SV, SY, TH, TJ, TM, TN, TR, TT, TZ, UA, UG, US, UZ, VC, VN, ZA, ZM, ZW.

(84) Designated States (unless otherwise indicated, for every kind of regional protection available): ARIPO (BW, GH, GM, KE, LR, LS, MW, MZ, NA, RW, SD, SL, SZ, TZ, UG, ZM, ZW), Eurasian (AM, AZ, BY, KG, KZ, RU, TJ, TM), European (AL, AT, BE, BG, CH, CY, CZ, DE, DK, EE, ES, FI, FR, GB, GR, HR, HU, IE, IS, IT, LT, LU, LV, MC, MK, MT, NL, NO, PL, PT, RO, RS, SE, SI, SK, SM, TR), OAPI (BF, BJ, CF, CG, CI, CM, GA, GN, GQ, GW, ML, MR, NE, SN, TD, TG).

[Continued on next page]

(54) Title: TISSUE EXTRACTION DEVICES AND METHODS

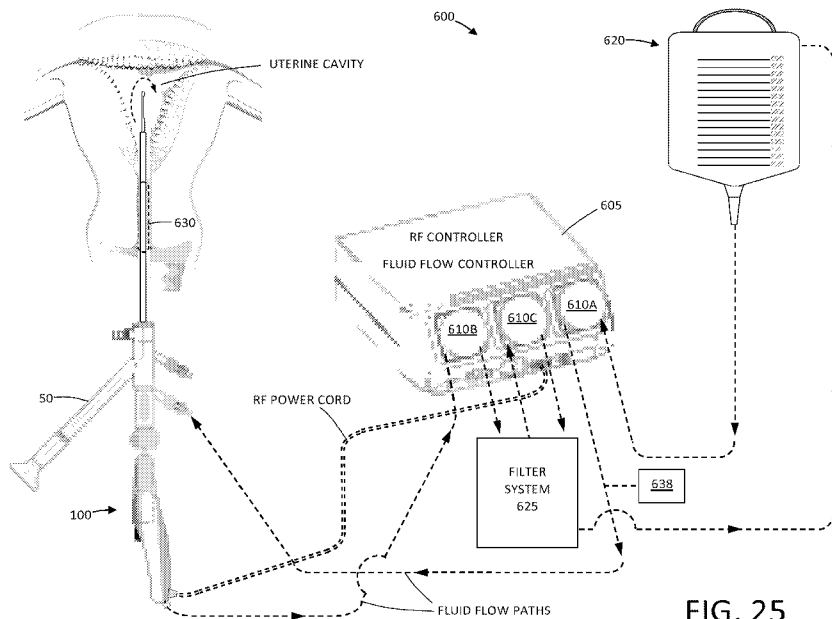

FIG. 25

(57) Abstract: Tissue may be cut and extracted from an interior location in a patient's body using a probe or tool which both effects cutting and causes vaporization of a liquid or other fluid to propel the cut tissue through an extraction lumen of the cutting device. The cutting may be achieved using an electrosurgical electrode assembly, including a first electrode on a cutting member and a second electrode within a cutting probe or tool.



Published:

— with international search report (Art. 21(3))

— before the expiration of the time limit for amending the claims and to be republished in the event of receipt of amendments (Rule 48.2(h))

TISSUE EXTRACTION DEVICES AND METHODS

CROSS-REFERENCE TO RELATED APPLICATIONS

[0001] The specification of this application includes Figs. 1-24 and the associated text from non-provisional application no. 13/277,913 (Attorney Docket No. 33291-712.201), the full disclosure of which is incorporated herein by reference.

FIELD OF THE INVENTION

[0002] The present invention relates systems and methods for the cutting and extraction of uterine fibroid tissue, polyps and other abnormal uterine tissue.

BACKGROUND OF THE INVENTION

[0003] Uterine fibroids are non-cancerous tumors that develop in the wall of uterus. Such fibroids occur in a large percentage of the female population, with some studies indicating that up to 40 percent of all women have fibroids. Uterine fibroids can grow over time to be several centimeters in diameter and symptoms can include menorrhagia, reproductive dysfunction, pelvic pressure and pain.

[0004] One current treatment of fibroids is hysteroscopic resection or myomectomy which involves transcervical access to the uterus with a hysteroscope together with insertion of a cutting instrument through a working channel in the hysteroscope. The cutting instrument may be a mechanical tissue cutter or an electrosurgical resection device such as a cutting loop. Mechanical cutting devices are disclosed in U.S. Pat. No. 7,226,459; 6,032,673 and 5,730,752 and U.S. Published Patent Appl. 2009/0270898. An electrosurgical cutting device is disclosed in U.S. Pat. No. 5,906,615.

[0005] While hysteroscopic resection can be effective in removing uterine fibroids, many commercially available instrument are too large in diameter and thus require anesthesia in an operating room environment. Conventional resectoscopes require cervical dilation to about 9 mm. What is needed is a system that can effectively cut and remove fibroid tissue through a small diameter hysteroscope.

SUMMARY OF THE INVENTION

[0006] The present invention provides methods for resecting and removing target tissue from a patient's body, such as fibroids from a uterus. The tissue is cut, captured in a probe, catheter, or other tissue-removal device, and expelled from the capture device by vaporizing a fluid, typically a liquid, adjacent to the captured tissue in order to propel the tissue from the device, typically through an extraction or other lumen present in a body or shaft of the device. Exemplary

embodiments, the tissue removal device comprise a reciprocating blade, tubular cutter, or the like, where the blade may be advanced past a cutting window on the device in order to sever a tissue strip and capture the strip within an interior volume or receptacle on the device. The liquid or other expandable fluid is also present in the device, and energy is applied to the fluid in order to cause rapid expansion, e.g. vaporization, in order to propel the severed tissue strip through the extraction lumen. In this way, the dimensions of the extraction lumen can be reduced, particularly in the distal regions of the device where size is of critical importance.

[0007] In a first method, according to the present invention, tissue is extracted from an interior of the patient's body by capturing a tissue volume in a distal portion of an interior passageway of an elongated probe. A fluid located distal to the captured tissue volume is expanded which proximally propels the tissue volume from the device. The fluid typically comprises a liquid, and the expansion typically comprises a liquid-to-vapor phase transition. In other cases, the fluid might be a gas where the expansion results from very rapid heating. In preferred embodiments, the phase transition is achieved by applying electrical energy in an amount sufficient to vaporize the liquid, typically applying RF current between first and second polarity electrodes, where at least one of the electrodes is disposed on a distal side of the captured tissue volume.

[0008] The liquid or other fluid may be provided to a working end of the probe in various ways. Often, the liquid or other fluid is provided from a fluid-filled space in the patient's body, for example from a distension fluid filled in the cavity to be treated, such as the uterus. Alternatively, the liquid or other fluid may be provided from a remote source through a passageway in the probe. The liquid volume to be vaporized is typically in the range from 0.004 mL to 0.080 mL.

[0009] The tissue may be captured in a variety of ways. For example, the tissue may be resected with a blade member or alternatively with an RF electrode. In either case, the resected tissue may then be captured or sequestered within an interior passageway within the blade itself and/or within another portion of the probe. In addition to the propulsion force caused by the vaporizing fluid, the present invention might also rely on applying a negative pressure to a proximal end of the anterior passageway to assist in drawing the tissue in a proximal direction from the extraction lumen.

[0010] In a further method according to the present invention, tissue is removed from the interior of a patient's body by engaging a tubular cutter against the targeted tissue. An RF electrode arrangement on the cutter is energized to electrosurgically cut the tissue, and the same or a different RF electrode is used to vaporize a liquid to apply a positive fluid pressure to a distal surface of the cut tissue. Usually, the same RF electrode arrangement is used to both electrosurgically cut the tissue and to vaporize the liquid. In such instances, the cutter carrying the RF electrode is usually first advanced to electrosurgically cut the tissue and thereafter advanced into the liquid to vaporize the liquid. The liquid is usually present in a chamber or other space having an active electrode at a distal end thereof, and the RF electrode arrangement

on the cutter comprises a return electrode. In this way, with the smaller active electrode on the distal side of the tissue, the energy which vaporizes the liquid will be concentrated in the chamber on the distal side of the tissue, thus causing rapid vaporization of the liquid and propulsion of the tissue through the extraction lumen.

[0011] In a third method according to the present invention, tissue is cut and extracted from the interior of a patient's body by reciprocating a cutting member within a tubular cutter body to sever a tissue strip. The severed tissue strip is captured in an extraction lumen of the tubular cutter body, and a phase transition is caused in a fluid distal to the tissue strip to thereby apply a proximally directed expelling or propulsion force to the tissue strip. The phase transition may be caused by applying energy from any one of a variety of energy sources, including an ultrasound transducer, a high-intensity focused ultrasound (HIFU) energy source, a laser energy source, a light or optical energy source, a microwave energy source, a resistive heat source, or the like. Typically, the cutter will carry the energy source, and the energy source is also used to effect cutting of the tissue. In this way the cutter can also carry the energy source into the fluid after the tissue has been cut, and the cutting and vaporization steps can be performed sequentially as the cutter first moves through the tissue and then into the liquid or other fluid to be vaporized.

[0012] In a still further method according to the present invention, tissue is cut and extracted by first cutting the tissue with a reciprocating cutting member over an extending stroke and a retracting stroke within a sleeve. The extending stroke cuts and captures tissue which has been drawn through a tissue-receiving window in the sleeve. Vaporization of a liquid distal to the captured tissue is caused by the cutting member while the cutting member is in a transition range between extension and retraction. The tissue is typically captured in the tissue extraction lumen formed at least partially in the cutter member. The cutter member typically carries a cutting electrode, and a second electrode is typically disposed at a distal end of the sleeve. Thus, RF current may be delivered to the cutting electrode and the second electrode in order to both effect cutting of the tissue over the extending stroke of the cutter and to also effect vaporization of the fluid while the cutter is in the transition range.

BRIEF DESCRIPTION OF DRAWINGS

[0013] FIG. 1 is a plan view of an assembly including a hysteroscope and a tissue-cutting device corresponding to the invention that is inserted through a working channel of the hysteroscope.

[0014] FIG. 2 is a schematic perspective view of a fluid management system used for distending the uterus and for assisting in electrosurgical tissue cutting and extraction.

[0015] FIG. 3 is a cross-sectional view of the shaft of the hysteroscope of FIG. 1 showing various channels therein.

[0016] FIG. 4 is a schematic side view of the working end of the electrosurgical tissue-cutting device of FIG. 1 showing an outer sleeve and a reciprocating inner sleeve and an electrode arrangement.

[0017] FIG. 5 is a schematic perspective view of the working end of the inner sleeve of FIG. 4 showing its electrode edge.

[0018] FIG. 6A is a schematic cut-away view of a portion of outer sleeve, inner RF cutting sleeve and a tissue-receiving window of the outer sleeve.

[0019] FIG. 6B is a schematic view of a distal end portion another embodiment of inner RF cutting sleeve.

[0020] FIG. 7A is a cross sectional view of the inner RF cutting sleeve of FIG. 6B taken along line 7A-7A of FIG. 6B.

[0021] FIG. 7B is another cross sectional view of the inner RF cutting sleeve of FIG. 6B taken along line 7B-7B of FIG. 6B.

[0022] FIG. 8 is a schematic view of a distal end portion of another embodiment of inner RF cutting sleeve.

[0023] FIG. 9A is a cross sectional view of the RF cutting sleeve of FIG. 8 taken along line 9A-9A of FIG. 8.

[0024] FIG. 9B is a cross sectional view of the RF cutting sleeve of FIG. 8 taken along line 9B-9B of FIG. 8.

[0025] FIG. 10A is a perspective view of the working end of the tissue-cutting device of FIG. 1 with the reciprocating RF cutting sleeve in a non-extended position.

[0026] FIG. 10B is a perspective view of the tissue-cutting device of FIG. 1 with the reciprocating RF cutting sleeve in a partially extended position.

[0027] FIG. 10C is a perspective view of the tissue-cutting device of FIG. 1 with the reciprocating RF cutting sleeve in a fully extended position across the tissue-receiving window.

[0028] FIG. 11A is a sectional view of the working end of the tissue-cutting device of FIG. 10A with the reciprocating RF cutting sleeve in a non-extended position.

[0029] FIG. 11B is a sectional view of the working end of FIG. 10B with the reciprocating RF cutting sleeve in a partially extended position.

[0030] FIG. 11C is a sectional view of the working end of FIG. 10C with the reciprocating RF cutting sleeve in a fully extended position.

[0031] FIG. 12A is an enlarged sectional view of the working end of tissue-cutting device of FIG. 11B with the reciprocating RF cutting sleeve in a partially extended position showing the RF field in a first RF mode and plasma cutting of tissue.

[0032] FIG. 12B is an enlarged sectional view of the working end of FIG. 11C with the reciprocating RF cutting sleeve almost fully extended and showing the RF fields switching to a second RF mode from a first RF mode shown in FIG. 12.

[0033] FIG. 12C is an enlarged sectional view of the working end of FIG. 11C with the reciprocating RF cutting sleeve again almost fully extended and showing the explosive vaporization of a captured liquid volume to expel cut tissue in the proximal direction.

[0034] FIG. 13 is an enlarged perspective view of a portion of the working end of FIG. 12C showing an interior chamber and a fluted projecting element.

[0035] FIG. 14 is a sectional view of the working end of FIG. 12C showing an interior chamber and a variation of a projecting element.

[0036] FIG. 15 is a sectional view of the working end of FIG. 12C showing an interior chamber and a variation of a projecting element configured to explosively vaporize the captured liquid volume.

[0037] FIG. 16A is a perspective view of an alternative working end with a rotational cutter in a window open position.

[0038] FIG. 16B is a perspective view of the working end of FIG. 16A with the rotating cutting element in a second position.

[0039] FIG. 16C is a view of the working end of FIGS. 16A-16B with the rotating cutting element in a third position.

[0040] FIG. 17 is an exploded view of the outer sleeve of the working end of FIGS. 16A-16C showing the mating components comprising a ceramic body and a metal tube.

[0041] FIG. 18 is a view of the inner sleeve of the working end of FIGS. 16A-16C de-mated from the outer sleeve.

[0042] FIG. 19 is an exploded view of the inner sleeve of FIG. 18 showing the mating components comprising a ceramic body and a metal tube.

[0043] FIG. 20A is a cross sectional view of the working end of FIGS. 16A-16C with the rotating inner sleeve in a first position cutting tissue in a first RF mode.

[0044] FIG. 20B is a cross sectional view of the working end of FIG. 20A with the rotating inner sleeve in a second window-closed position with a second RF mode vaporizing saline captured in the interior extraction channel.

[0045] FIG. 21 is a longitudinal sectional view corresponding to the view of FIG. 20B with the rotating inner sleeve in a window-closed position and with the second RF mode vaporizing saline captured in the interior extraction channel to expel tissue proximally.

[0046] FIG. 22 is a view of an alternative embodiment of a metal tube component of an inner sleeve.

[0047] FIG. 23 is a view of an alternative embodiment of a metal tube component of an inner sleeve.

[0048] FIG. 24 is a perspective view of an alternative probe that is configured to stop the inner rotating sleeve in a particular position.

[0049] FIG. 25 is a schematic view of another fluid management system corresponding to the invention.

[0050] FIG. 26 is a diagram showing various pump and filter components of the fluid management system of FIG. 25.

[0051] FIG. 27 is a sectional view of an RF probe that is configured to stop the inner rotating sleeve in a particular position to coagulate tissue.

DETAILED DESCRIPTION OF THE INVENTION

[0052] FIG. 1 illustrates an assembly that comprises an endoscope 50 used for hysteroscopy together with a tissue-extraction device 100 extending through a working channel 102 of the endoscope. The endoscope or hysteroscope 50 has a handle 104 coupled to an elongated shaft 105 having a diameter of 5 mm to 7 mm. The working channel 102 therein may be round, D-shaped or any other suitable shape. The endoscope shaft 105 is further configured with an optics channel 106 and one or more fluid inflow/outflow channels 108a, 108b (FIG. 3) that communicate with valve-connectors 110a, 110b configured for coupling to a fluid inflow source 120 thereto, or optionally a negative pressure source 125 (FIGS. 1-2). The fluid inflow source 120 is a component of a fluid management system 126 as is known in the art (FIG. 2) which comprises a fluid container 128 and pump mechanism 130 which pumps fluid through the hysteroscope 50 into the uterine cavity. As can be seen in FIG. 2, the fluid management system 126 further includes the negative pressure source 125 (which can comprise an operating room wall suction source) coupled to the tissue-cutting device 100. The handle 104 of the endoscope includes the angled extension portion 132 with optics to which a videoscopic camera 135 can be operatively coupled. A light source 136 also is coupled to light coupling 138 on the handle of the hysteroscope 50. The working channel 102 of the hysteroscope is configured for insertion and manipulation of the tissue-cutting and extracting device 100, for example to treat and remove fibroid tissue. In one embodiment, the hysteroscope shaft 105 has an axial length of 21 cm, and can comprise a 0° scope, or 15° to 30° scope.

[0053] Still referring to FIG. 1, the tissue-cutting device 100 has a highly elongated shaft assembly 140 configured to extend through the working channel 102 in the hysteroscope. A handle 142 of the tissue-cutting device 100 is adapted for manipulating the electrosurgical working end 145 of the device. In use, the handle 142 can be manipulated both rotationally and axially, for example, to orient the working end 145 to cut targeted fibroid tissue. The tissue-cutting device 100 has subsystems coupled to its handle 142 to enable electrosurgical cutting of

targeted tissue. A radiofrequency generator or RF source 150 and controller 155 are coupled to at least one RF electrode carried by the working end 145 as will be described in detail below. In one embodiment shown in FIG. 1, an electrical cable 156 and negative pressure source 125 are operatively coupled to a connector 158 in handle 142. The electrical cable couples the RF source 150 to the electrosurgical working end 145. The negative pressure source 125 communicates with a tissue-extraction channel 160 in the shaft assembly 140 of the tissue extraction device 100 (FIG. 4).

[0054] FIG. 1 further illustrates a seal housing 162 that carries a flexible seal 164 carried by the hysteroscope handle 104 for sealing the shaft 140 of the tissue-cutting device 100 in the working channel 102 to prevent distending fluid from escaping from a uterine cavity.

[0055] In one embodiment as shown in FIG. 1, the handle 142 of tissue-cutting device 100 includes a motor drive 165 for reciprocating or otherwise moving a cutting component of the electrosurgical working end 145 as will be described below. The handle 142 optionally includes one or more actuator buttons 166 for actuating the device. In another embodiment, a footswitch can be used to operate the device. In one embodiment, the system includes a switch or control mechanism to provide a plurality of reciprocation speeds, for example 1 Hz, 2 Hz, 3 Hz, 4 Hz and up to 8 Hz. Further, the system can include a mechanism for moving and locking the reciprocating cutting sleeve in a non-extended position and in an extended position. Further, the system can include a mechanism for actuating a single reciprocating stroke.

[0056] Referring to FIGS. 1 and 4, an electrosurgical tissue-cutting device has an elongate shaft assembly 140 extending about longitudinal axis 168 comprising an exterior or first outer sleeve 170 with passageway or lumen 172 therein that accommodates a second or inner sleeve 175 that can reciprocate (and optionally rotate or oscillate) in lumen 172 to cut tissue as is known in that art of such tubular cutters. In one embodiment, the tissue-receiving window 176 in the outer sleeve 170 has an axial length ranging between 10 mm and 30 mm and extends in a radial angle about outer sleeve 170 from about 45° to 210° relative to axis 168 of the sleeve. The outer and inner sleeves 170 and 175 can comprise a thin-wall stainless steel material and function as opposing polarity electrodes as will be described in detail below. FIGS. 6A-8 illustrate insulative layers carried by the outer and inner sleeves 170 and 175 to limits, control and/or prevent unwanted electrical current flows between certain portions of the sleeve. In one embodiment, a stainless steel outer sleeve 170 has an O.D. of 0.143" with an I.D. of 0.133" and with an inner insulative layer (described below) the sleeve has a nominal I.D. of 0.125". In this embodiment, the stainless steel inner sleeve 175 has an O.D. of 0.120" with an I.D. of 0.112". The inner sleeve 175 with an outer insulative layer has a nominal O.D. of about 0.123" to 0.124" to reciprocate in lumen 172. In other embodiments, outer and/or inner sleeves can be fabricated of metal, plastic, ceramic or a combination thereof. The cross-section of the sleeves can be round, oval or any other suitable shape.

[0057] As can be seen in FIG. 4, the distal end 177 of inner sleeve 175 comprises a first polarity electrode with distal cutting electrode edge 180 about which plasma can be generated. The electrode edge 180 also can be described as an active electrode during tissue cutting since the electrode edge 180 then has a substantially smaller surface area than the opposing polarity or return electrode. In one embodiment in FIG. 4, the exposed surfaces of outer sleeve 170 comprises the second polarity electrode 185, which thus can be described as the return electrode since during use such an electrode surface has a substantially larger surface area compared to the functionally exposed surface area of the active electrode edge 180.

[0058] In one aspect of the invention, the inner sleeve or cutting sleeve 175 has an interior tissue extraction lumen 160 with first and second interior diameters that are adapted to electrosurgically cut tissue volumes rapidly—and thereafter consistently extract the cut tissue strips through the highly elongated lumen 160 without clogging. Now referring to FIGS. 5 and 6A, it can be seen that the inner sleeve 175 has a first diameter portion 190A that extends from the handle 142 (FIG. 1) to a distal region 192 of the sleeve 175 wherein the tissue extraction lumen transitions to a smaller second diameter lumen 190B with a reduced diameter indicated at B which is defined by the electrode sleeve element 195 that provides cutting electrode edge 180. The axial length C of the reduced cross-section lumen 190B can range from about 2 mm to 20 mm. In one embodiment, the first diameter A is 0.112” and the second reduced diameter B is 0.100”. As shown in FIG. 5, the inner sleeve 175 can be an electrically conductive stainless steel and the reduced diameter electrode portion also can comprise a stainless steel electrode sleeve element 195 that is welded in place by weld 196 (FIG. 6A). In another alternative embodiment, the electrode and reduced diameter electrode sleeve element 195 comprises a tungsten tube that can be press fit into the distal end 198 of inner sleeve 175. FIGS. 5 and 6A further illustrates the interfacing insulation layers 202 and 204 carried by the first and second sleeves 170, 175, respectively. In FIG. 6A, the outer sleeve 170 is lined with a thin-wall insulative material 200, such as PFA, or another material described below. Similarly, the inner sleeve 175 has an exterior insulative layer 202. These coating materials can be lubricious as well as electrically insulative to reduce friction during reciprocation of the inner sleeve 175.

[0059] The insulative layers 200 and 202 described above can comprise a lubricious, hydrophobic or hydrophilic polymeric material. For example, the material can comprise a bio-compatible material such as PFA, TEFLON[®], polytetrafluoroethylene (PTFE), FEP (Fluorinated ethylenepropylene), polyethylene, polyamide, ECTFE (Ethylenechlorotrifluoro-ethylene), ETFE, PVDF, polyvinyl chloride or silicone.

[0060] Now turning to FIG. 6B, another variation of inner sleeve 175 is illustrated in a schematic view together with a tissue volume being resected with the plasma electrode edge 180. In this embodiment, as in other embodiments in this disclosure, the RF source operates at selected operational parameters to create a plasma around the electrode edge 180 of electrode sleeve 195 as is known in the art. Thus, the plasma generated at electrode edge 180 can cut and

ablate a path P in the tissue 220, and is suited for cutting fibroid tissue and other abnormal uterine tissue. In FIG. 6B, the distal portion of the cutting sleeve 175 includes a ceramic collar 222 which is adjacent the distal edge 180 of the electrode sleeve 195. The ceramic 222 collar functions to confine plasma formation about the distal electrode edge 180 and functions further to prevent plasma from contacting and damaging the polymer insulative layer 202 on the cutting sleeve 175 during operation. In one aspect of the invention, the path P cut in the tissue 220 with the plasma at electrode edge 180 provides a path P having an ablated width indicated at W, wherein such path width W is substantially wide due to tissue vaporization. This removal and vaporization of tissue in path P is substantially different than the effect of cutting similar tissue with a sharp blade edge, as in various prior art devices. A sharp blade edge can divide tissue (without cauterization) but applies mechanical force to the tissue and may prevent a large cross section slug of tissue from being cut. In contrast, the plasma at the electrode edge 180 can vaporize a path P in tissue without applying any substantial force on the tissue to thus cut larger cross sections or slugs strips of tissue. Further, the plasma cutting effect reduces the cross section of tissue strip 225 received in the tissue-extraction lumen 190B. FIG. 6B depicts a tissue strip to 225 entering lumen 190B which has such a smaller cross-section than the lumen due to the vaporization of tissue. Further, the cross section of tissue 225 as it enters the larger cross-section lumen 190A results in even greater free space 196 around the tissue strip 225. Thus, the resection of tissue with the plasma electrode edge 180, together with the lumen transition from the smaller cross-section (190B) to the larger cross-section (190A) of the tissue-extraction lumen 160 can significantly reduce or eliminate the potential for successive resected tissue strips 225 to clog the lumen. Prior art resection devices with such small diameter tissue-extraction lumen typically have problems with tissue clogging.

[0061] In another aspect of the invention, the negative pressure source 225 coupled to the proximal end of tissue-extraction lumen 160 (see FIGS. 1 and 4) also assists in aspirating and moving tissue strips 225 in the proximal direction to a collection reservoir (not shown) outside the handle 142 of the device.

[0062] FIGS. 7A-7B illustrate the change in lumen diameter of cutting sleeve 175 of FIG. 6B. FIG. 8 illustrates the distal end of a variation of cutting sleeve 175' which is configured with an electrode cutting element 195' that is partially tubular in contrast to the previously described tubular electrode element 195 (FIGS. 5 and 6A). FIGS. 9A-9B again illustrate the change in cross-section of the tissue-extraction lumen between reduced cross-section region 190B' and the increased cross-section region 190A' of the cutting sleeve 175' of FIG. 8. Thus, the functionality remains the same whether the cutting electrode element 195' is tubular or partly tubular. In FIG. 8A, the ceramic collar 222' is shown, in one variation, as extending only partially around sleeve 175 to cooperate with the radial angle of cutting electrode element 195'. Further, the variation of FIG. 8 illustrates that the ceramic collar 222' has a larger outside diameter than insulative layer 202. Thus, friction may be reduced since the short axial length of

the ceramic collar 222' interfaces and slides against the interfacing insulative layer 200 about the inner surface of lumen 172 of outer sleeve 170.

[0063] In general, one aspect of the invention comprises a tissue cutting and extracting device (FIGS. 10A-11C) that includes first and second concentric sleeves having an axis and wherein the second (inner) sleeve 175 has an axially-extending tissue-extraction lumen therein, and wherein the second sleeve 175 is moveable between axially non-extended and extended positions relative to a tissue-receiving window 176 in first sleeve 170 to resect tissue, and wherein the tissue extraction lumen 160 has first and second cross-sections. The second sleeve 175 has a distal end configured as a plasma electrode edge 180 to resect tissue disposed in tissue-receiving window 176 of the first sleeve 170. Further, the distal end of the second sleeve, and more particularly, the electrode edge 180 is configured for plasma ablation of a substantially wide path in the tissue. In general, the tissue-extraction device is configured with a tissue extraction lumen 160 having a distal end portion with a reduced cross-section that is smaller than a cross-section of medial and proximal portions of the lumen 160.

[0064] In one aspect of the invention, referring to FIGS. 7A-7B and 9A-9B, the tissue-extraction lumen 160 has a reduced cross-sectional area in lumen region 190A proximate the plasma cutting tip or electrode edge 180 wherein said reduced cross section is less than 95%, 90%, 85% or 80% than the cross sectional area of medial and proximal portions 190B of the tissue-extraction lumen, and wherein the axial length of the tissue-extraction lumen is at least 10 cm, 20 cm, 30 cm or 40 cm. In one embodiment of tissue-cutting device 100 for hysteroscopic fibroid cutting and extraction (FIG. 1), the shaft assembly 140 of the tissue-cutting device is 35 cm in length.

[0065] FIGS. 10A-10C illustrate the working end 145 of the tissue-cutting device 100 with the reciprocating cutting sleeve or inner sleeve 175 in three different axial positions relative to the tissue receiving window 176 in outer sleeve 170. In FIG. 10 A, the cutting sleeve 175 is shown in a retracted or non-extended position in which the sleeve 175 is at its proximal limit of motion and is prepared to advance distally to an extended position to thereby electro-surgically cut tissue positioned in and/or suctioned into window 176. FIG. 10B shows the cutting sleeve 175 moved and advanced distally to a partially advanced or medial position relative to tissue cutting window 176. FIG. 10C illustrates the cutting sleeve 175 fully advanced and extended to the distal limit of its motion wherein the plasma cutting electrode 180 has extended past the distal end 226 of tissue-receiving window 176 at which moment the resected tissue strip 225 is excised from tissue volume 220 and captured in reduced cross-sectional lumen region 190A.

[0066] Now referring to FIGS. 10A-10C, FIGS. 11A-11C and FIGS. 12A-12C, another aspect of the invention comprises "tissue displacement" mechanisms provided by multiple elements and processes to "displace" and move tissue strips 225 (FIG. 12A) in the proximal direction in lumen 160 of cutting sleeve 175 to thus ensure that tissue does not clog the lumen of the inner sleeve 175. As can be seen in FIG. 10A and the enlarged views of FIGS. 11A-11C, one tissue

displacement mechanism comprises a projecting element 230 that extends proximally from distal tip 232 which is fixedly attached to outer sleeve 170. The projecting element 230 extends proximally along central axis 168 in a distal chamber 240 defined by outer sleeve 170 and distal tip 232. In one embodiment depicted in FIG. 11A, the shaft-like projecting element 230, in a first functional aspect, comprises a mechanical pusher that functions to push a captured tissue strip 225 proximally from the small cross-section lumen 190B of cutting sleeve 175 (FIG. 12A) as the cutting sleeve 175 moves to its fully advanced or extended position.

[0067] In a second functional aspect, the chamber 240 in the distal end of sleeve 170 is configured to capture a volume of saline distending fluid 244 (FIG. 12A) from the working space, and wherein the existing RF electrodes of the working end 145 are further configured to explosively vaporize the captured fluid 244 to generate proximally-directed forces on tissue strips 225 resected and disposed in lumen 160 of the cutting sleeve 175 (FIGS. 12B and 12C). Both of these functional elements and processes (tissue displacement mechanisms) can apply a substantial mechanical force on the captured tissue strips 225 by means of the explosive vaporization of liquid in chamber 240 and can function to move tissue strips 225 in the proximal direction in the tissue-extraction lumen 160. It has been found that using the combination of multiple functional elements and processes can virtually eliminate the potential for tissue clogging the tissue extraction lumen 160.

[0068] More particularly, FIGS. 12A-12C illustrate the functional aspects of the tissue displacement mechanisms and the subsequent explosive vaporization of fluid captured in chamber 240. In FIG. 12A, the reciprocating cutting sleeve 175 is shown in a medial position advancing distally wherein plasma at the cutting electrode edge 180 is cutting a tissue strip 225 that is disposed within lumen 160 of the cutting sleeve 175. In FIG. 12A-12C, it can be seen that the system operates in first and second electrosurgical modes corresponding to the reciprocation and axial range of motion of cutting sleeve 175 relative to the tissue-receiving window 176. As used herein, the term “electrosurgical mode” refers to which electrode of the two opposing polarity electrodes functions as an “active electrode” and which electrode functions as a “return electrode”. The terms “active electrode” and “return electrode” are used in accordance with convention in the art—wherein an active electrode has a smaller surface area than the return electrode which thus focuses RF energy density about such an active electrode. In the working end 145 of FIGS. 10A-11C, the cutting electrode element 195 and its cutting electrode edge 180 must comprise the active electrode to focus energy about the electrode to generate the plasma for tissue cutting. Such a high-intensity, energetic plasma at the electrode edge 180 is needed throughout stroke X indicated in FIG. 12A-12B to cut tissue. The first mode occurs over an axial length of travel of inner cutting sleeve 175 as it crosses the tissue-receiving window 176, at which time the entire exterior surface of outer sleeve 170 comprises the return electrode indicated at 185. The electrical fields EF of the first RF mode are indicated generally in FIG. 12A.

[0069] FIG. 12 B illustrates the moment in time at which the distal advancement or extension of inner cutting sleeve 175 entirely crosses the tissue-receiving window 176 (FIG. 12A). At this time, the electrode sleeve 195 and its electrode edge 180 are confined within the mostly insulated-wall chamber 240 defined by the outer sleeve 170 and distal tip 232. At this moment, the system is configured to switch to the second RF mode in which the electric fields EF switch from those described previously in the first RF mode. As can be seen in FIG. 12B, in this second mode, the limited interior surface area 250 (FIG. 12C) of distal tip 232 that interfaces chamber 240 functions as an active electrode and the distal end portion of cutting sleeve 175 exposed to chamber 240 acts as a return electrode. In this mode, very high energy densities occur about surface 250 and such a contained electric field EF can explosively and instantly vaporize the fluid 244 captured in chamber 240. The expansion of water vapor can be dramatic and can thus apply tremendous mechanical forces and fluid pressure on the tissue strip 225 to move the tissue strip in the proximal direction in the tissue extraction lumen 160. FIG. 12C illustrates such explosive or expansive vaporization of the distention fluid 244 captured in chamber 240 and further shows the tissue strip 225 being expelled in the proximal direction the lumen 160 of inner cutting sleeve 175.

[0070] FIG. 14 shows the relative surface areas of the active and return electrodes at the extended range of motion of the cutting sleeve 175, again illustrating that the surface area of the non-insulated distal end surface 250 is small compared to surface 255 of electrode sleeve which comprises the return electrode.

[0071] Still referring to FIGS. 12A-12C, it has been found that a single power setting on the RF source 150 and controller 155 can be configured both (i) to create plasma at the electrode cutting edge 180 of electrode sleeve 195 to cut tissue in the first mode, and (ii) to explosively vaporize the captured distention fluid 244 in the second mode. Further, it has been found that the system can function with RF mode-switching automatically at suitable reciprocation rates ranging from 0.5 cycles per second to 8 or 10 cycles per second. In bench testing, it has been found that the tissue-cutting device described above can cut and extract tissue at the rate of from 4 grams/min to 8 grams/min without any potential for tissue strips 225 clogging the tissue-extraction lumen 160. In these embodiments, the negative pressure source 125 also is coupled to the tissue-extraction lumen 160 to assist in applying forces for tissue extraction.

[0072] Of particular interest, the fluid-capture chamber 240 defined by sleeve 170 and distal tip 232 can be designed to have a selected volume, exposed electrode surface area, length and geometry to optimize the application of expelling forces to resected tissue strips 225. In one embodiment, the diameter of the chamber is 3.175 mm and the length is 5.0 mm which taking into account the projecting element 230, provided a captured fluid volume of approximately 0.040 mL. In other variations, the captured fluid volume can range from 0.004 mL to 0.080 mL.

[0073] In one example, a chamber 240 with a captured liquid volume of 0.040 mL together with 100% conversion efficiency in and instantaneous vaporization would require 103 Joules to

heat the liquid from room temperature to water vapor. In operation, since a Joule is a $W \cdot s$, and the system reciprocate at 3 Hz, the power required would be on the order of 311 W for full, instantaneous conversion to water vapor. A corresponding theoretical expansion of 1700x would occur in the phase transition, which would result in up to 25,000 psi instantaneously ($14.7 \text{ psi} \times 1700$), although due to losses in efficiency and non-instantaneous expansion, the actual pressures would be much less. In any event, the pressures are substantial and can apply significant expelling forces to the captured tissue strips 225.

[0074] Referring to FIG. 12A, the interior chamber 240 can have an axial length from about 0.5 mm to 10 mm to capture a liquid volume ranging from about 0.004 mL to 0.01 mL. It can be understood in FIG. 12A, that the interior wall of chamber 240 has an insulator layer 200 which thus limits the electrode surface area 250 exposed to chamber 240. In one embodiment, the distal tip 232 is stainless steel and is welded to outer sleeve 170. The post element 248 is welded to tip 232 or machined as a feature thereof. The projecting element 230 in this embodiment is a non-conductive ceramic.

[0075] FIG. 13 shows the cross-section of the ceramic projecting element 230 which may be fluted, and which in one embodiment has three flute elements 260 and three corresponding axial grooves 262 in its surface. Any number of flutes, channels or the like is possible, for example from two to about 20. The fluted design increases the available cross-sectional area at the proximal end of the projecting element 230 to push the tissue strip 225, while at the same time the three grooves 262 permit the proximally-directed jetting of water vapor to impact the tissue exposed to the grooves 262. In one embodiment, the axial length D (FIG. 12A) of the projecting element 230 is configured to push tissue entirely out of the reduced cross-sectional region 190B of the electrode sleeve element 195. In another embodiment, the volume of the chamber 240 is configured to capture liquid that when explosively vaporized provided a gas (water vapor) volume sufficient to expand into and occupy at least the volume defined by a 10% of the total length of extraction channel 160 in the device, usually at least 20% of the extraction channel 160, often at least 40% of the extraction channel 160, sometimes at least 60% of the extraction channel 160, other times at least 80% of the extraction channel 160, and sometimes at least 100% of the extraction channel 160.

[0076] As can be understood from FIGS. 12A to 12C, the distending fluid 244 in the working space replenishes the captured fluid in chamber 240 as the cutting sleeve 175 moves in the proximal direction or towards its non-extended position. Thus, when the cutting sleeve 175 again moves in the distal direction to cut tissue, the interior chamber 240 is filled with fluid 244 which is then again contained and is then available for explosive vaporization as described above when the cutting sleeve 175 closes the tissue-receiving window 176. In another embodiment, a one-way valve can be provided in the distal tip 232 to draw fluid directly into interior chamber 240 without the need for fluid to migrate through window 176.

[0077] FIG. 15 illustrates another variation in which the active electrode surface area 250' in the second mode comprises a projecting element 230 with conductive regions and non-conductive regions 260 which can have the effect of distributing the focused RF energy delivery over a plurality of discrete regions each in contact with the captured fluid 244. This configuration can more efficiently vaporize the captured fluid volume in chamber 240. In one embodiment, the conductive regions 250' can comprise metal discs or washers on post 248. In other variation (not shown) the conductive regions 250' can comprise holes, ports or pores in a ceramic material 260 fixed over an electrically conductive post 248.

[0078] In another embodiment, the RF source 150 and controller 155 can be programmed to modulate energy delivery parameters during stroke X and stroke Y in FIGS. 12A-12C to provide the optimal energy (i) for plasma cutting with electrode edge 180, and (ii) for explosively vaporizing the captured fluid in chamber 240.

[0079] FIGS. 16A-16C illustrate another embodiment RF cutting probe 700 with working end 702 comprising a tubular cutter adapted for electrosurgical cutting and extracting targeted tissue from the interior of a patient's body. However, in this embodiment, the inner cutting sleeve is configured to rotate instead of reciprocate as in the previously-described embodiments.

[0080] Referring to FIG. 16A, the outer sleeve 705 comprises a metal tubular member 708 that extends from a handle (not shown) to a working end 702 that again carries a distal dielectric body 710 defining a window 712 therein. The inner second sleeve or cutting sleeve 715 comprises a metal tubular member 718 that carries a distal dielectric body 720 with a windowed side 724 that is adapted to cooperate with window 712 in the outer sleeve 705.

[0081] FIGS. 16B-16C show the working end 702 of probe 700 with the rotating cutting sleeve 715 and RF electrode edge 725 in two different rotational positions with respect to outer sleeve 705 and window 712. In FIG. 16B, the inner sleeve 715 is rotated approximately 90° relative to the outer sleeve 705. In FIG. 16C, the inner sleeve 715 is rotated 180° to a position relative to inner sleeve 715 to effectively close the window 712 defined by the outer sleeve 705. It can easily be understood how rotation of electrode edge 725 thus can cut tissue during rotation and capture the tissue in the window-closed position within the tissue-receiving lumen 730 of the probe.

[0082] In this embodiment of FIGS. 16A-16C, the RF electrode edge 725 of the inner sleeve 715 comprises a first polarity electrode. The exterior surface 732 of the outer sleeve 705 comprises a second polarity electrode as described in previous embodiments. As can be understood from FIGS. 16A-16C, it is critical that the first and second polarity electrode surfaces (725 and 732) are spaced apart by a predetermined dimension throughout the rotation of inner sleeve 715 relative to outer sleeve 705. In one aspect the invention, the distal ends of the inner and outer sleeves comprise ceramic bodies 710 and 720 with an interface 740 therebetween. In other words, the ceramic bodies 710 and 720 rotate about interface 740 and the bodies provide exact electrode spacing ES between the first and second polarity electrodes 725 and 732.

[0083] Now referring to FIG. 17, it can be seen how the outer sleeve 705 comprises as an assembly between the tubular metal sleeve 708 and the dielectric body 710, which in this variation can be a ceramic such as zirconium. In FIG. 17, it can be seen that the ceramic body 710 has a thin wall 742 which can range in thickness from about 0.003" and 0.010" wherein the ceramic extends 360° around window 712. Ceramic body 710 can thus be slidably inserted into and bonded to bore 728 in metal sleeve 708.

[0084] Now turning to FIG. 18, the distal end of inner sleeve 715 is shown de-mated from the outer sleeve assembly 705 (see FIG. 16A). The tubular metal sleeve 718 of FIG. 18 is fabricated to allow insertion of the ceramic body 720 which supports the electrode edge 725 and provides a rotational bearing surface about the interface 740 (see FIG. 16A). FIG. 19 shows an exploded view of the inner sleeve assembly of FIG. 18. In FIG. 19, it can be seen that ceramic body 720 has a hemispherical cross-sectional shape and includes an elongated slots 744 for receiving and supporting an electrode edge 725. FIG. 19 further shows metal sleeve 718 without ceramic body 720 wherein the electrode edge 725 is cut from a rounded end sleeve 718. It can be understood that the slot 744 can receive ceramic body 720 and thus the electrode edge 725 extends in a loop and under rotation will have a leading edge 745 and a trailing edge 745' depending on the direction of rotation. As used herein, the term 'leading edge' refers to the electrode edge 725 extending around the distal end of the sleeve 715 to its centerline on its rotational axis.

[0085] In one aspect of the invention, the tissue cutting probe 700 comprises an outer sleeve 705 and an inner sleeve 715 that is rotatable to provide window-open and window-closed positions and wherein the distal ends of the first and second sleeves 705, 715 include ceramic bodies 710, 720 that provide surfaces on either side of a rotational interface 740. Further, the first and second sleeves provide ceramic bodies 710, 720 that contact one another on either side of the rotational interface 740 and thus provide a predetermined electrode spacing ES (FIG. 16A). In one variation, the wall thickness of the ceramic body 710 is from 0.003" to 0.004". Likewise, the wall thickness of ceramic body 720 can be from 0.003" to 0.004". Thus, the radial dimension between the first and second polarity electrodes at a minimum in this variation is 0.006". In another variation in which the inner sleeve 715 carries an outer polymeric dielectric layer which can be 0.001" in thickness to thus provide an electrode spacing dimension ES of 0.004". In other variations having a larger diameter, the dimension between the first and second polarity electrodes can range up to 0.030". In general, the scope of the invention includes providing a rotational tubular cutter with bi-polar electrodes spaced apart between 0.004" inches and 0.030" inches wherein the cutting sleeve 715 rotates about an interface 740 having dielectric materials on either side thereof.

[0086] In the embodiment shown in FIGS. 16A-16C, the length of the window can range from about 5 mm to 30 mm. The diameter of the probe working end can range from about 3 mm to 6 mm or more. The rotational speed of the inner sleeve can range from 100 rpm to 5,000 rpm. In

one embodiment, a rotation ranging from about 200 rpm to 500 rpm cut tissue efficiently and allowed for effective tissue extraction as described below.

[0087] In another aspect of the invention, referring to FIGS. 17, 20A and 20B, it can be seen that an opening 748 is provided in ceramic body 710 which provides exposure through the ceramic body 701 to metal sleeve 708 which comprises the first polarity electrode when assembled. Thus, the metal sleeve provides an interior electrode surface 750 that is exposed to interior chamber 730. It can be understood that in this variation, the working end 702 can function in two RF modes as described in the previous reciprocating probe embodiments (see FIGS. 12A-12C). In the first RF mode, the exterior surface 732 of outer sleeve 705 functions as a first polarity electrode in the interval when the inner sleeve 715 and its second polarity electrode edge 725 rotates from the window-open position of FIG. 16A toward the window-closed position of FIG. 16B. FIG. 20A depicts this interval of rotation, wherein it can be seen that the first RF mode operates for approximately 180° of rotation of the inner cutting sleeve 715. In this position depicted in FIG. 20A, the leading edge 745 and trailing edge 745' of electrode edge 725 are exposed to the open window 712 and electric fields EF extend to the first polarity electrode surface 732 about the exterior of the probe and plasma is formed at leading electrode edge 745 to cut tissue.

[0088] The second RF mode is shown in FIG. 20B, wherein the inner sleeve 715 rotates to the window-closed position and the probe switches instantly to such a second RF mode since the electrode edge 725 is exposed only to the tissue-receiving lumen 730. It can be understood that the second RF mode operates only when the window 712 is closed as in FIGS. 16C and 20B which causes the instant explosive vaporization of captured saline in the lumen 730. In FIG. 20B, it can be seen that the electrode edge 725 is exposed only to the interior of lumen 730 and electric fields EF extend between the leading and trailing electrode edges (745 and 745') to the exposed electrode surface 750 to thus cause the explosive vaporization of captured saline. The vaporization occurs instantly within limited degrees of rotation of the inner sleeve, e.g., 5° to 20° of rotation, upon closing the window 712 to thereby expel the resected tissue in the proximal direction as described previously. It has been found that saline captured in the interior channel 730 can be distal to the resected tissue or adjacent to the resected tissue in the lumen and the fluid expansion in the liquid-to-vapor transition will instantly expel the resected tissue outwardly or proximally in lumen 730.

[0089] FIG. 21 is a longitudinal sectional view of the working end 702 corresponding to FIG. 20B wherein the electrical fields EF are confined within the interior lumen 730 to thus cause the explosive vaporization of captured saline. Thus, the second RF mode and the vaporization of captured saline 754 as depicted in FIG. 20B will expel the resected tissue 755 proximally within the tissue extraction channel 730 that extends proximally through the probe to a collection reservoir as described in previous embodiments. In general, a method of the invention includes capturing a tissue volume in a closed distal portion of an interior passageway of an elongate

probe and causing a phase transition in a fluid proximate to the captured tissue volume to expand the fluid to apply a proximally directed expelling force to the tissue volume. The time interval for providing a closed window to capture the tissue and for causing the explosive vaporization can range from about 0.01 second to 2 seconds. A negative pressure source also can be coupled to the proximal end of the extraction lumen as described previously.

[0090] Now turning to FIG. 22, another variation of inner sleeve 715' is shown. In this embodiment, the leading edge 745 and the trailing edge 745' of electrode edge 725 are provided with different electrical characteristics. In one variation, the leading edge 745 is a highly conductive material suited for plasma ignition as described previously. In this same variation shown in FIG. 22, the trailing edge 745' comprises a different material which is less suited for plasma formation, or entirely not suited for plasma formation. In one example, the trailing edge 745' comprises a resistive material (e.g., a resistive surface coating) wherein RF current ignites plasma about the leading edge 745 but only resistively heats the trailing 745' edge to thus provide enhanced coagulation functionality. Thus, the leading edge 745 cuts and the trailing edge 745' is adapted to coagulate the just-cut tissue. In another variation, the trailing edge 745' can be configured with a capacitive coating which again can be used for enhancing tissue coagulation. In yet another embodiment, the trailing edge 745' can comprise a positive temperature coefficient of resistance (PTCR) material for coagulation functionality and further for preventing tissue sticking. In another variation, the trailing edge 745' can have a dielectric coating that prevents heating altogether so that the leading edge 745 cut tissues and the trailing edge 745' has no electrosurgical functionality.

[0091] FIG. 23 illustrates another embodiment of inner sleeve component 718' in which the electrode edge 725 has a leading edge 745 with edge features for causing a variable plasma effect. In this embodiment, the projecting edges 760 of the leading edge 745 electrode will create higher energy density plasma than the scalloped or recessed portions 762 which can result to more efficient tissue cutting. In another embodiment, the electrode surface area of the leading edge 745 and trailing edge 745' can differ, again for optimizing the leading edge 745 for plasma cutting and the trailing edge 745' for coagulation. In another embodiment, the trailing edge 745' can be configured for volumetric removal of tissue by plasma abrasion of the just-cut surface since it wiped across the tissue surface. It has been found that a substantial amount of tissue (by weight) can be removed by this method wherein the tissue is disintegrated and vaporized. In general, the leading edge 745 and trailing edge 745' can be dissimilar with each edge optimized for a different effect on tissue.

[0092] FIG. 24 illustrates another aspect of the invention that can be adapted for selective cutting or coagulating of targeted tissue. In this variation, a rotation control mechanism is provided to which can move the inner sleeve 715 to provide the leading electrode edge 745 in an exposed position and further lock the leading edge 745 in such an exposed position. In this locked (non-rotating) position, the physician can activate the RF source and controller to ignite

plasma along the exposed leading edge 745 and thereafter the physician can use the working end as a plasma knife to cut tissue. In another variation, the physician can activate the RF source and controller to provide different RF parameters configured to coagulate tissue rather than to cut tissue. In one embodiment, a hand switch or foot switch can upon actuation move and lock the inner sleeve in the position shown in FIG. 24 and thereafter actuate the RF source to deliver energy to tissue.

[0093] FIGS. 25 and 26 are schematic illustrations and block diagrams of one embodiment of fluid management system 600 corresponding to the invention that is configured for hysteroscopic use with the probes as described above. As can be seen in FIG. 21, the hysteroscope 50 and tissue cutting probe 100 can deliver a cavity-distending fluid to the uterine cavity as described previously. In one embodiment, the fluid management system 600 includes a controller 605 that carries first, second and third peristaltic pumps 610A, 610B and 610C. The peristaltic pump can control pressures throughout the system and provide predetermined flow rates into the uterine cavity and outward from the uterine cavity. A predetermined flow rate and/or pressure can be used to distend the uterine cavity to thereby allow the physician to view tissue targeted for treatment. Of particular interest, the system 600 as shown in FIGS. 25 and 26 eliminates the need to weigh fluid volumes to determine fluid deficit (and potential intravasation) which is found in prior art systems. The fluid management system 600 in FIG. 25 comprises fluid-in/fluid-out system in which a volume of fluid is recirculated from a fluid source 620 into the uterine cavity and then outward from the uterine cavity into a filtering and sterilization subsystem 625. After the fluid is filtered and sterilized, it is returned to the fluid source 620 which is typically a gravity-feed saline bag as illustrated in FIGS. 25 and 26.

[0094] In using the fluid management system 600 of FIG. 25, the physician only needs to monitor the change in volume of fluid in the saline source or bag 620 to determine the fluid deficit. A cervical seal 630 is provided to prevent any substantial saline leakage outward from the uterine cavity around the hysteroscope 50. Similarly, the hysteroscope has a seal 630 in its working channel to prevent leakage around the shaft of the tissue cutting probe 100.

[0095] In one embodiment as shown in FIG. 25, the plurality of peristaltic pumps 610A-610C are utilized to provide saline inflows into the uterine cavity as well comprising a negative pressure source (pump 610B) to withdraw saline and resected tissue from the uterine cavity.

[0096] As can be seen in FIG. 26, a first peristaltic pump 610A is configured as a saline inflow pump and is positioned below the saline bag or source 620. In one variation, a section of polyurethane tubing is engaged by the peristaltic pump 610A which can consist of 3/8" OD; 1/4" ID tubing. Other flexible inflow tubing 635 not engaged by peristaltic pump 610A can consist of 1/4" OD 1/8" ID tubing of PVC. A pressure sensor 638 is provided downstream from the peristaltic pump 610A used for saline infusion. The pressure sensor 638 is coupled to the controller 605 and can pressure feedback signals can be used to modulate fluid inflows into the uterine cavity.

[0097] Still referring to FIG. 26, it can be seen that pump 610B is configured as a negative pressure pump mechanism to extract fluid and resected tissue through flexible tubing 640, for example a 3/8" OD; 1/4" ID tubing rating as a vacuum tubing. In FIG. 22, the second peristaltic pump 610B or vacuum pump is provided to withdraw fluid from the probe 100 as well as drive the fluid into a first tissue collection filter 650. In one embodiment, the tissue collection filter 650 is a coarse filter that can have any suitable form factor and can contain melt spun polypropylene fibers that provide a 1 μ filtering pore size. In one example, the filter 650 can be a McMaster Carr product having item number 5165K21 which has a diameter of about 2.5" and a length of about 9.75". As can be seen in FIG. 26, resected tissue 652 is collected in the bottom of the filter assembly 650 for later collection for biopsy purposes.

[0098] The third peristaltic pump 610C comprises a high-pressure pump and is downstream from the coarse filter 650. The high-pressure pump 610C is adapted to drive the coarsely filtered fluid through a molecular filter 660 which is capable of removing all cells, blood constituents and the like in the fluid flow. In one embodiment, the molecular filter 660 is a Nephros DSU filter available from Nephros, Inc., 41 Grand Ave., River Edge, NJ 07661. As can be further seen in FIG. 22, downstream from the molecular filter 660 is a return flow tubing 662 that returns the cleansed and sterilized fluid to the saline source or bag 620.

[0099] Of particular interest, molecular filter 660 is configured to allow re-infusion of a distending fluid into the patient. In effect, the molecular filter 660 is capable of cold sterilization of the saline or other fluid before it returned to the saline source or bag 620.

[00100] The pressure sensor 638 can be used to measure in-line pressures and can be used to modulate the pressure inside the uterus via the controller. In one variation, the pressure sensor is air pressure sensor (converted from the water pressure through a balloon within a pulse dampener) to measure and control the pressure inside the uterus. In another embodiment, the probe 100 or hysteroscope 50 can carry a pressure sensor for measuring uterine cavity pressure and can be operatively connected to the controller 605.

[00101] In an other aspect of the invention, referring again to FIG. 25, a method of use for cutting tissue from a targeted site in a space or potential space in a patient's body comprise utilizing the controller to modulate RF parameters in response to rates of fluid flow into an out of the space in the patient's body. This aspect of the invention is enabled by the fact that a single controller is provided (i) to control the RF cutting probe and (ii) to control the saline fluid inflows and outflow. More in particular, a method of the invention for cutting tissue in a body space comprises circulating a fluid through the space with a first flow into the space and a second flow out of the space to thereby occupy or distend the space; actuating an RF probe to perform a cutting procedure at the site; and modulating an operating parameter of the RF probe in response to a rate of the first or second flow.

[00102] Additional aspects of the method of cutting tissue include accessing the space with an endoscope, providing a first flow of conductive fluid into the space with the pump mechanism

comprising a peristaltic pump. A second flow of fluid is provide to move fluid out of the space which is again assisted by another peristaltic pump. The non-compliant aspects of the peristaltic pumps are important for controlling distending pressure in the body cavity, for example a uterine cavity. Further, the fact that the second flow through the probe varies depending on whether the cutting window is opened or closed and whether tissue contact is substantial or insubstantial make it important to have the capability to adjust an RF parameter in response to inflows and outflow, or a derivative parameter such as intra-cavity pressure.

[00103] Thus, in the method described above, the operating parameter of the RF probe can comprise RF power applied through the probe to tissue. In another embodiment, the operating parameter of the RF probe comprises the movement of an RF cutting component, which may be rotational speed of the RF cutting component, the speed of reciprocation of the RF cutting component, or axial-rotational oscillation of the RF cutting component. In another embodiment, the operating parameter of the RF probe can comprise movement of a non-RF component of the working end such as a moveable outer or inner sleeve (or partial sleeve) or other element for cleaning tissue from the electrode surface. In another embodiment, the operating parameter of the RF probe can comprise a duty cycle or pulse rate of the applied RF energy or duty cycle of the movement of the RF cutting component.

[00104] In another aspect of the invention, an operating parameter of the RF probe comprises a position of an RF cutting component relative to a tissue-receiving window. Referring to FIG. 27, a method corresponding to the invention comprises rotating the inner sleeve and stopping the sleeve in the maximum window-open position with the RF delivery off, applying suction to the central channel to suction tissue into the window, and then applying RF power to the bi-polar electrodes to coagulate tissue stabilized and captured in and about the window.

[00105] The methods described above are applicable to any space or potential space in a patient's body and are particularly suited for fibroid removal from a uterine cavity or removing tissue from within a joint.

[00106] In a fibroid treatment, the system utilizes a flow rate for saline inflows into the uterine cavity that ranges between about 100 ml/min and 1,600 ml/min. In one embodiment, the fluid management system is configured to maintain a selected distending pressure it the uterine cavity by modulating only inflow rates provided by a first peristaltic pump controlled by the controller, with a constant outflow rate provided by a second peristaltic pump, with controller algorithms responsive to RF probe parameters including: (i) the degree of window-open or window-closed positions which affects outflow volume; (ii) whether RF power is ON or OFF, and (iii) the degree of tissue contact or engagement with the window which can be measured by impedance or capacitive signals from the bi-polar RF electrodes or other dedicated electrodes.

[00107] In another method of the invention for cutting tissue from a targeted site in a uterine cavity, the measured or calculated pressure in the cavity can be used to modulate an operating parameter. In general, a method comprises circulating a fluid though the space with a fluid

inflow into the space and a fluid outflow from the space to thereby occupy or distend the space, actuating an RF probe to perform a cutting procedure at the site and modulating an operating parameter of an RF probe and/or the fluid management system in response to fluid pressure in the space. The operating parameter of the RF probe can be at least one of the following: applied RF power, RF pulse rate, RF duty cycle, rotational and/or axial movement of an RF electrode component of the probe, rotational and/or axial movement of a non-RF component of the probe, fluid inflow into the space, or fluid outflow from the space.

[00108] Another method of treating tissue in a targeted site in a space in a patient's body, comprising the steps of positioning the working end of an RF probe in the space, applying RF current to tissue from a moving RF electrode to perform a cutting procedure at the site and applying RF current to tissue from a non-moving RF electrode to perform a coagulation procedure at the site. The system and method include providing and utilizing a controller to selectively move or terminate movement of the RF electrode cutting component. Thus, the probe suctions tissue into the window of the working end to permit the moving RF electrode to cut tissue and optionally suctions tissue into the window of the working end to permit the non-moving RF electrode to coagulate tissue.

[00109] It should be appreciated that while an RF source is suitable for causing explosive vaporization of the captured fluid volume to expel or extract tissue as described above, any other energy source can be used and falls within the scope of the invention, such as an ultrasound transducer, HIFU, a laser or light energy source, a microwave or a resistive heat source.

[00110] In another embodiment, the probe can be configured with a lumen in communication with a remote liquid source to deliver fluid to the interior chamber 240.

[00111] Although particular embodiments of the present invention have been described above in detail, it will be understood that this description is merely for purposes of illustration and the above description of the invention is not exhaustive. Specific features of the invention are shown in some drawings and not in others, and this is for convenience only and any feature may be combined with another in accordance with the invention. A number of variations and alternatives will be apparent to one having ordinary skills in the art. Such alternatives and variations are intended to be included within the scope of the claims. Particular features that are presented in dependent claims can be combined and fall within the scope of the invention. The invention also encompasses embodiments as if dependent claims were alternatively written in a multiple dependent claim format with reference to other independent claims.

WHAT IS CLAIMED IS:

1. A system for cutting tissue from a targeted site in a space or potential space in a patient's body, comprising:
 - means for circulating a fluid through the space with a first flow into the space and a second flow out of the space to thereby occupy or distend the space;
 - means for actuating an RF probe to perform a cutting procedure at the site; and
 - means for modulating an operating parameter of the RF probe in response to a rate of the first or second flow.
2. The system of claim 1 including means for accessing the space with an endoscope.
3. The system of claim 1 wherein the means for circulating a first flow into the space comprises a peristaltic pump.
4. The system of claim 1 wherein the means for circulating a second flow out of the space is assisted by a peristaltic pump.
5. The system of claim 1 wherein the means for modulating modulates power.
6. The system of claim 1 wherein the means for modulating modulates movement of an RF cutting component.
7. The system of claim 1 wherein the means for modulating modulates rotational speed of an RF cutting component.
8. The system of claim 1 wherein the means for modulating modulates speed of reciprocation of an RF cutting component.
9. The system of claim 1 wherein the means for modulating modulates movement of a non-RF component.

10. The system of claim 1 wherein the means for modulating modulates a duty cycle or pulse rate.
11. The system of claim 1 wherein the means for modulating modulates a position of an RF cutting component relative to a tissue-receiving window.
12. The system of claim 1 wherein the probe is configured to be introduced into a uterine cavity.
13. The system of claim 1 wherein the probe is configured to be introduced into a joint.
14. The system of claim 1 wherein the first flow has a rate of at least 100 ml/min.
15. The system of claim 1 wherein the fluid comprises saline.
16. The system of claim 15 further comprising a saline source having a volume of less than about 3 liters.
17. The system of claim 1 wherein the second flow is passed through at least one filter and returned the saline source.
18. A system treating tissue in a targeted site in a space in a patient's body, comprising the steps of:
 - means for RF probe in the space;
 - means for applying RF current to tissue from a moving RF electrode to perform a cutting procedure at the site; and
 - means for applying RF current to tissue from a non-moving RF electrode to perform a coagulation procedure at the site.
19. The system of claim 18 further comprising a controller to selectively move or terminate movement of the RF electrode.

20. The method of claim 18 further comprising means for suctioning tissue into the window of the working end to permit the moving RF electrode to cut tissue.

21. The system of claim 18 further comprising means for circulating a conductive fluid through the space with a fluid inflow into the space at a rate of at least 100 ml/min.

22. The system of claim 21 wherein the conductive fluid is saline.

1/29

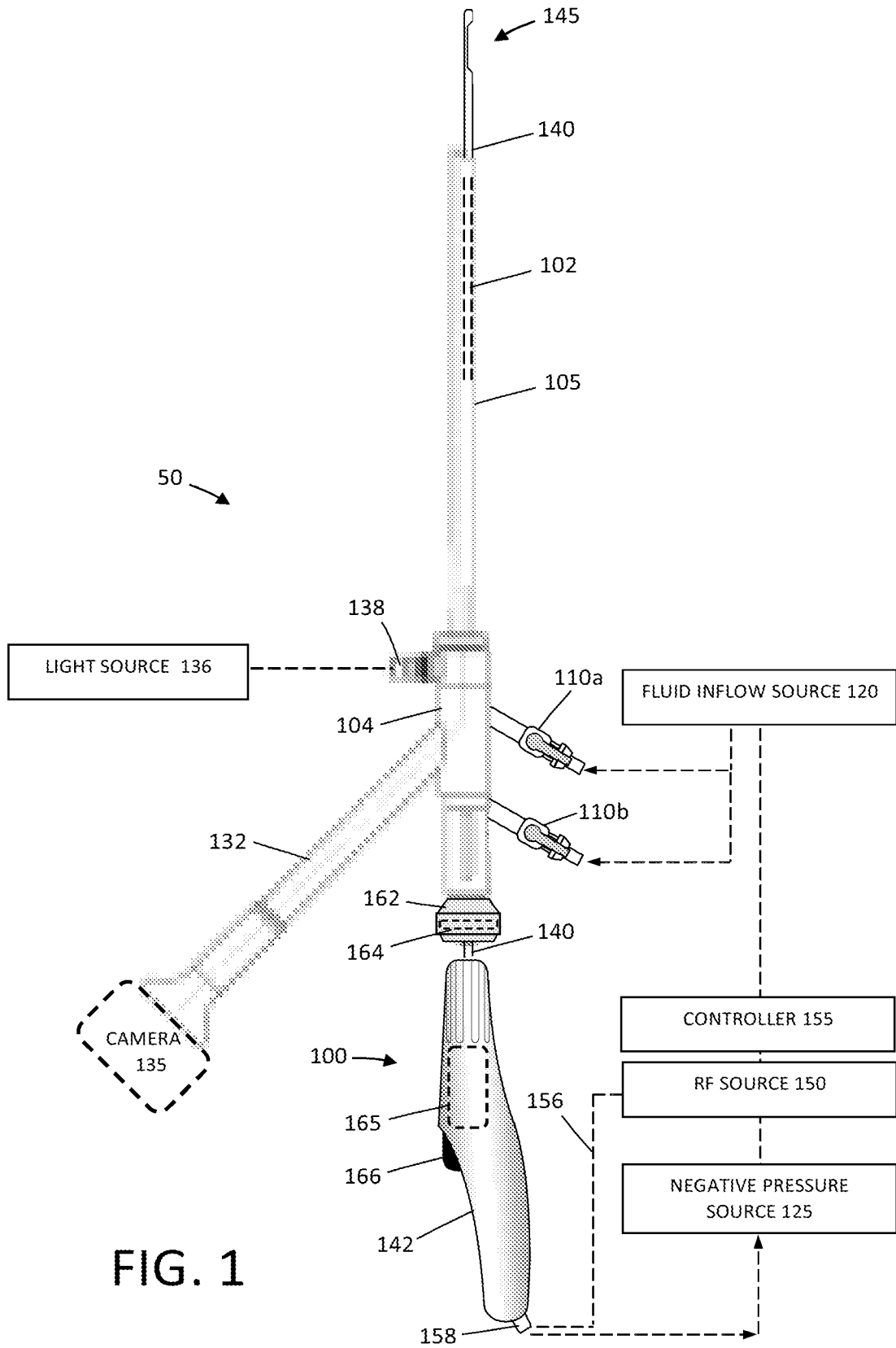

FIG. 1

FLUID MANAGEMENT
SYSTEM 126

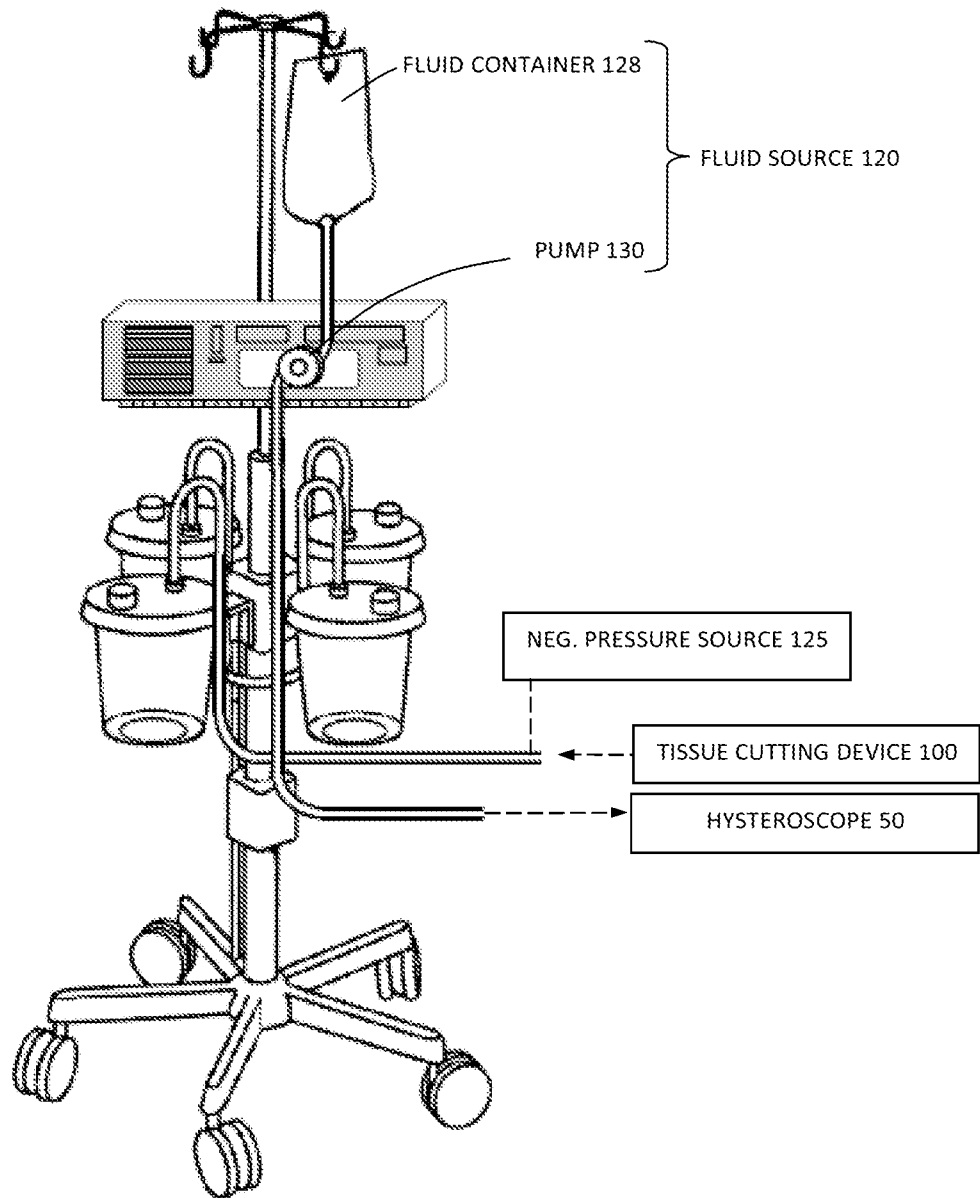

FIG. 2

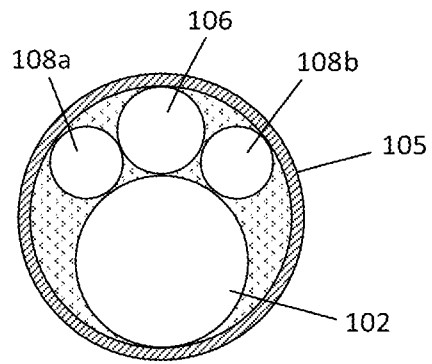

FIG. 3

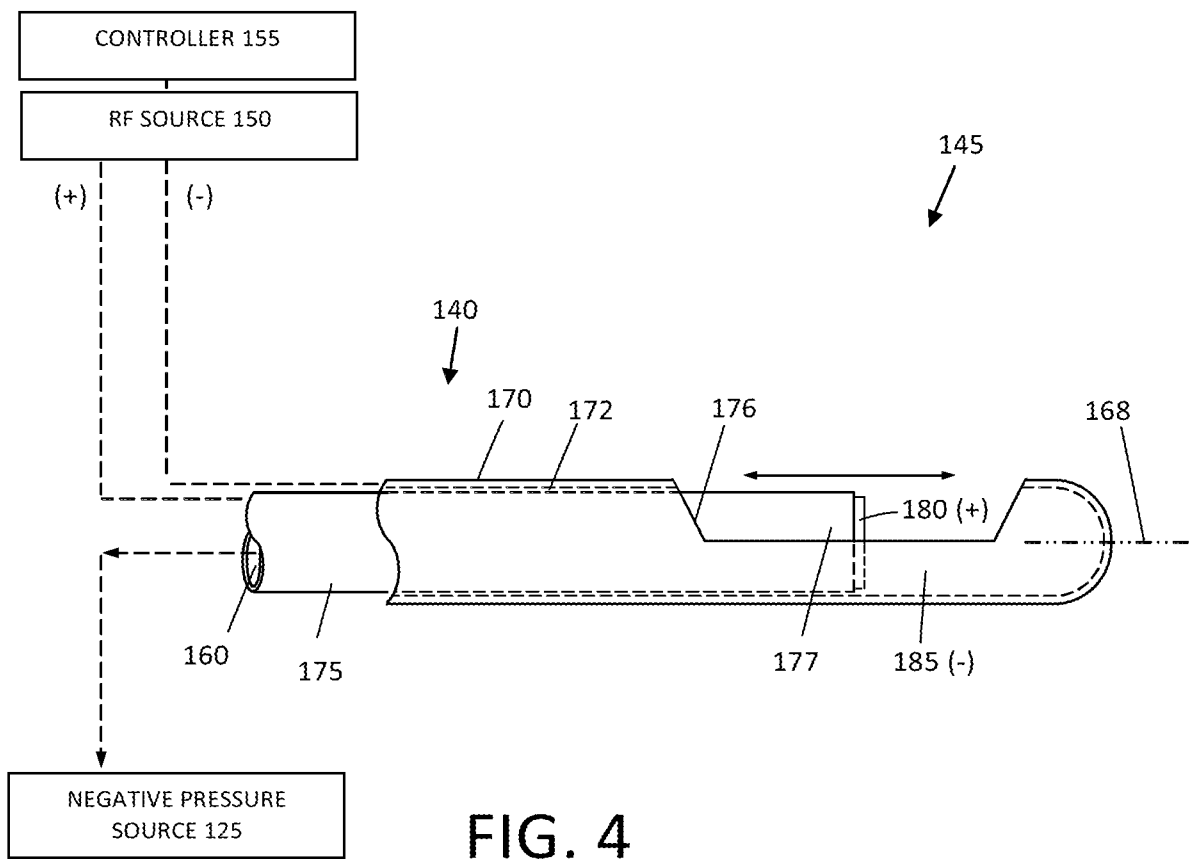

FIG. 4

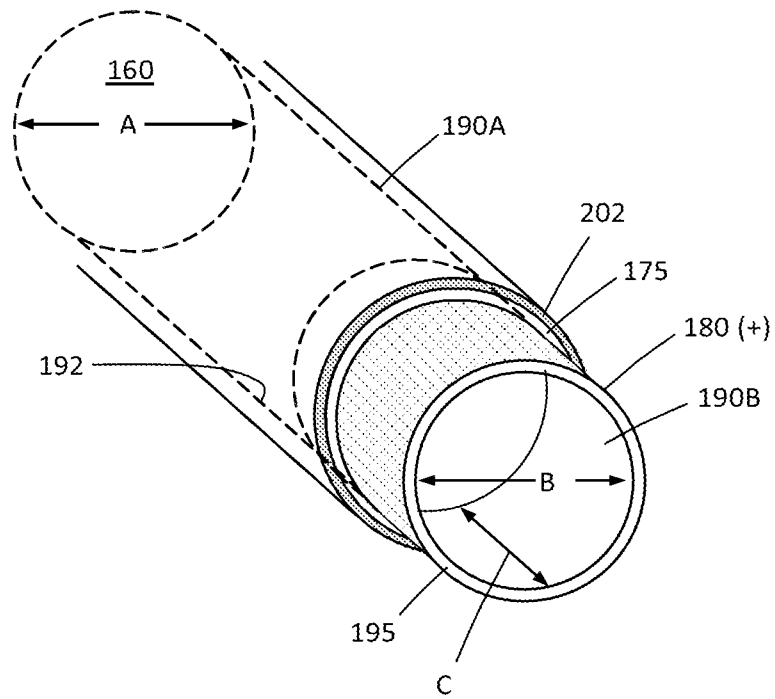

FIG. 5

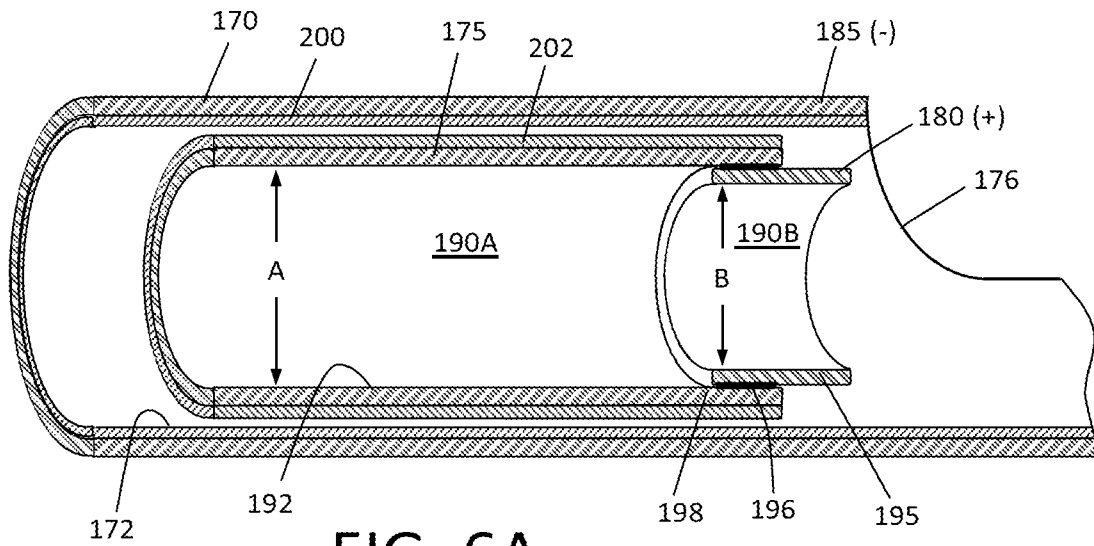

FIG. 6A

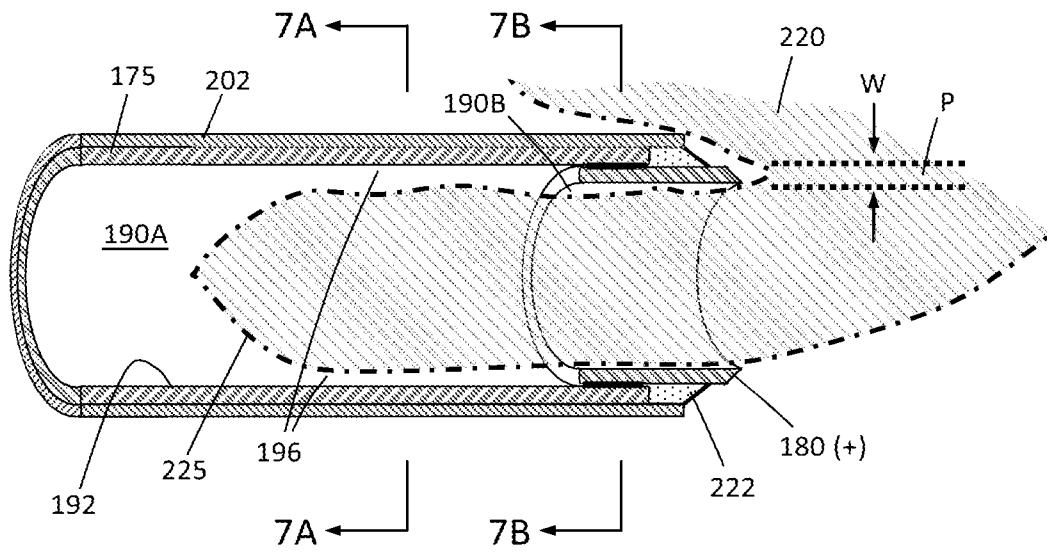

FIG. 6B

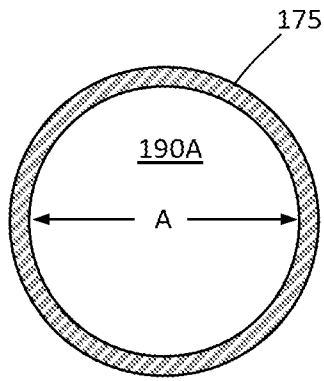

FIG. 7A

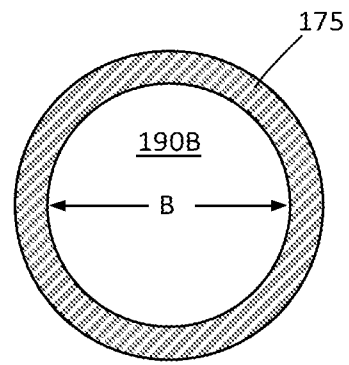

FIG. 7B

8/29

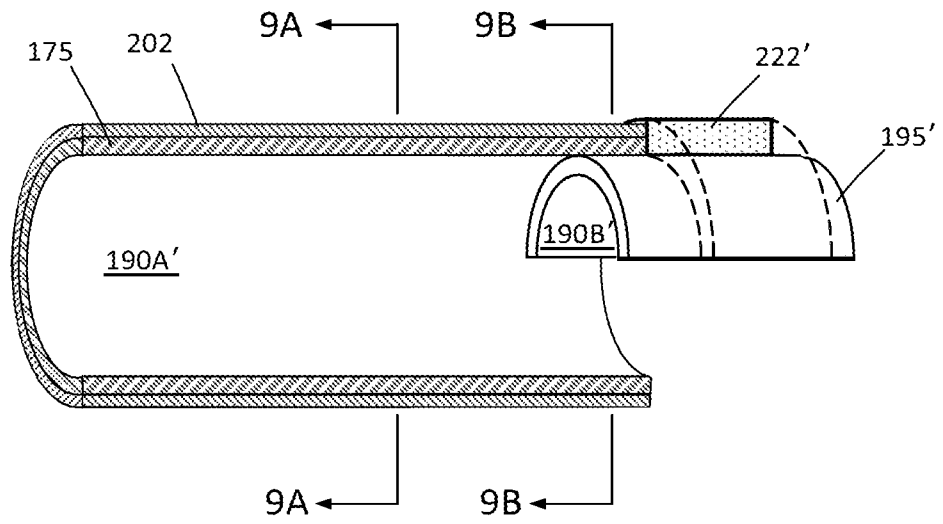

FIG. 8

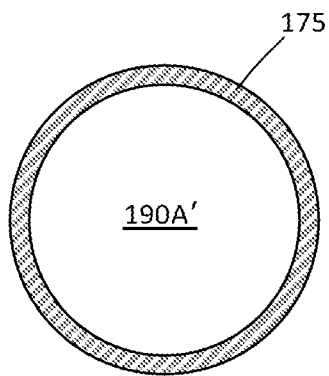

FIG. 9A

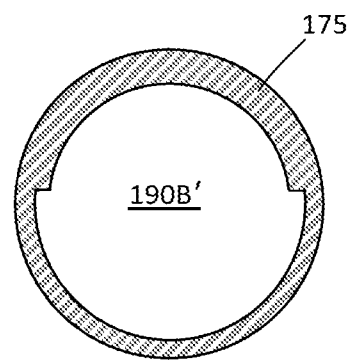

FIG. 9B

9/29

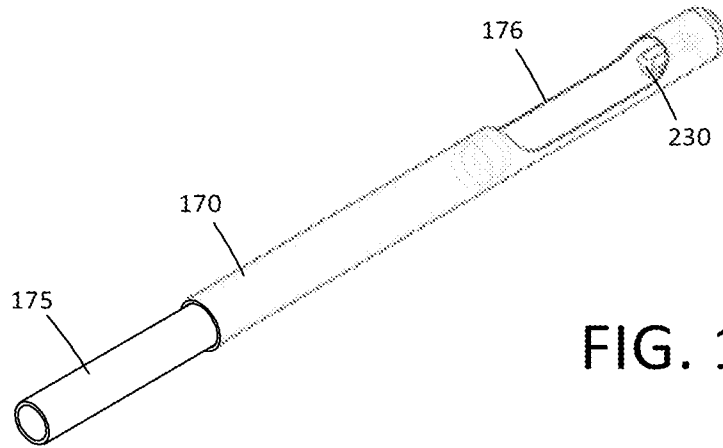

FIG. 10A

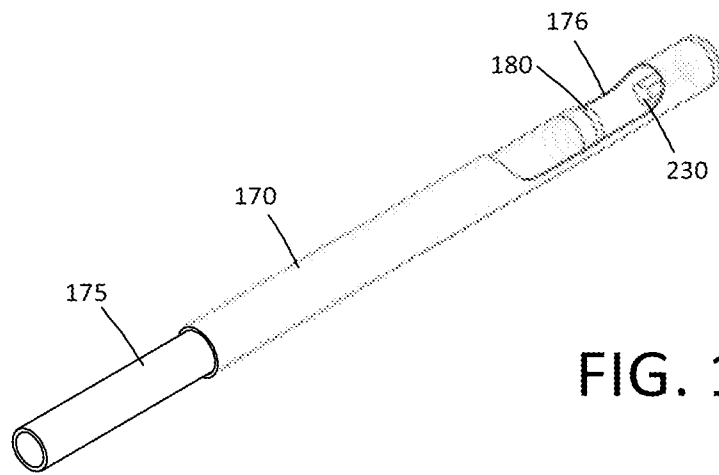

FIG. 10B

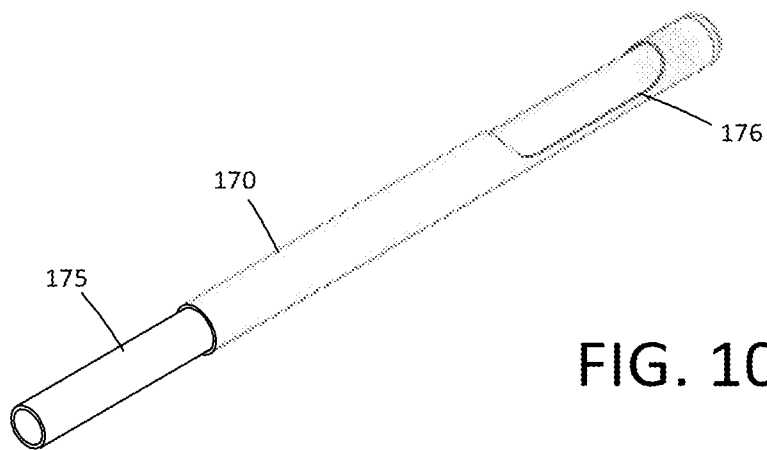

FIG. 10C

10/29

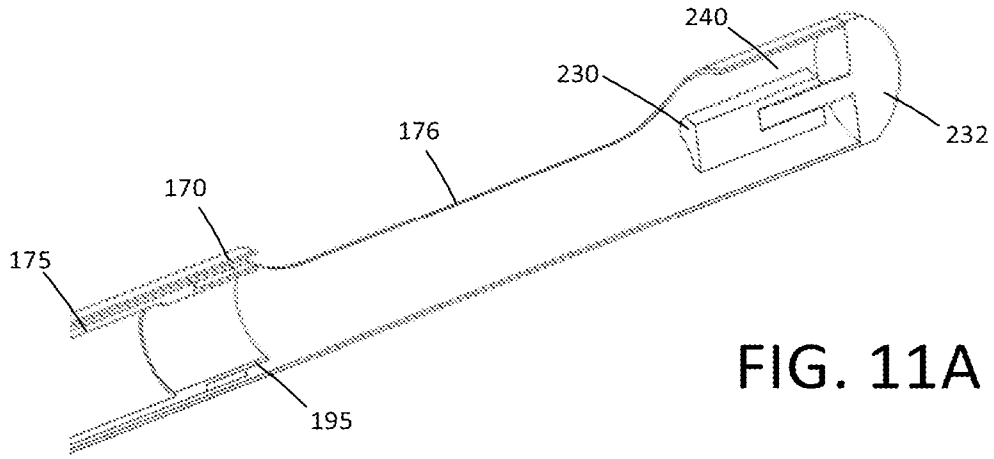

FIG. 11A

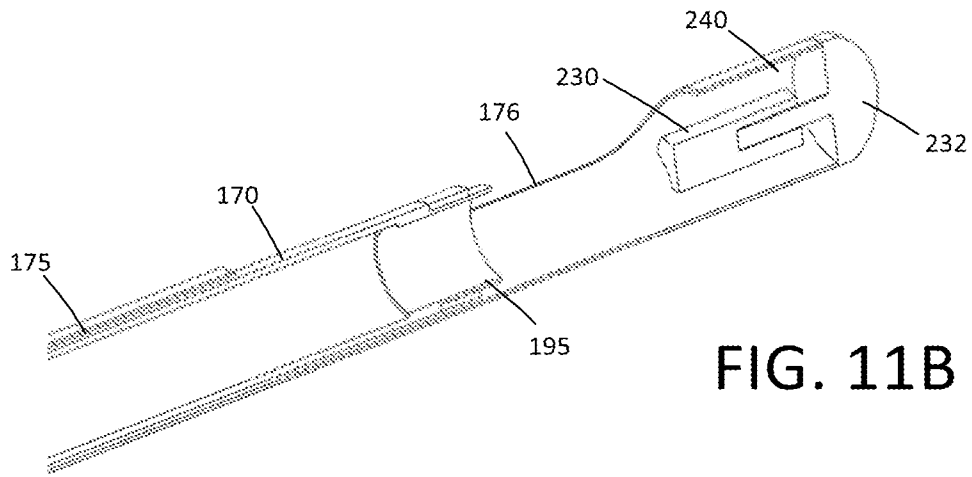

FIG. 11B

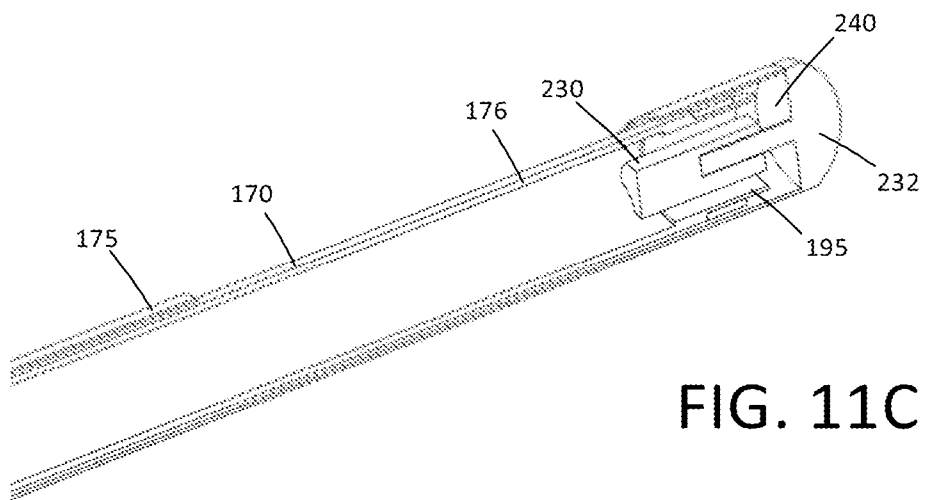

FIG. 11C

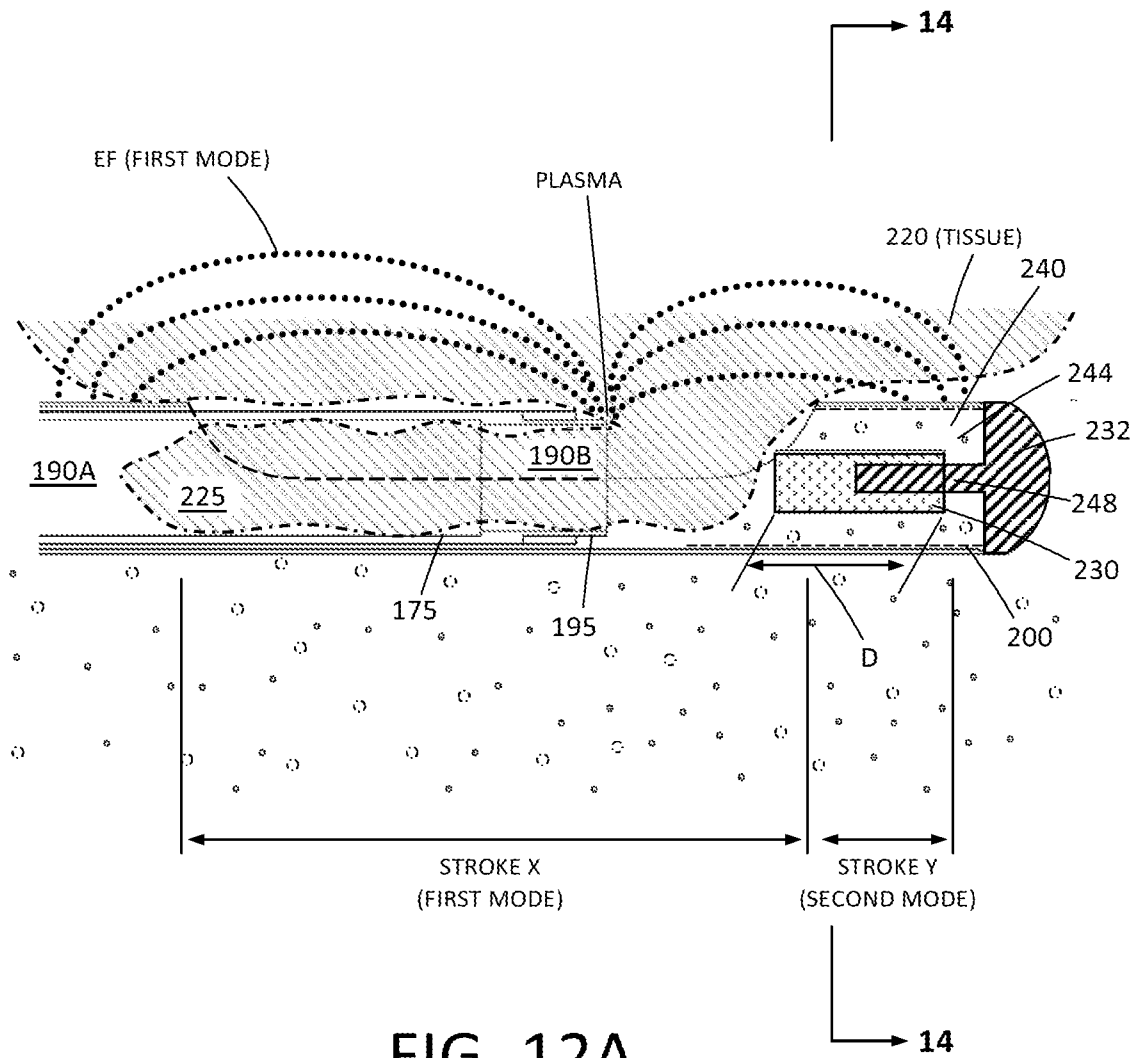

FIG. 12A

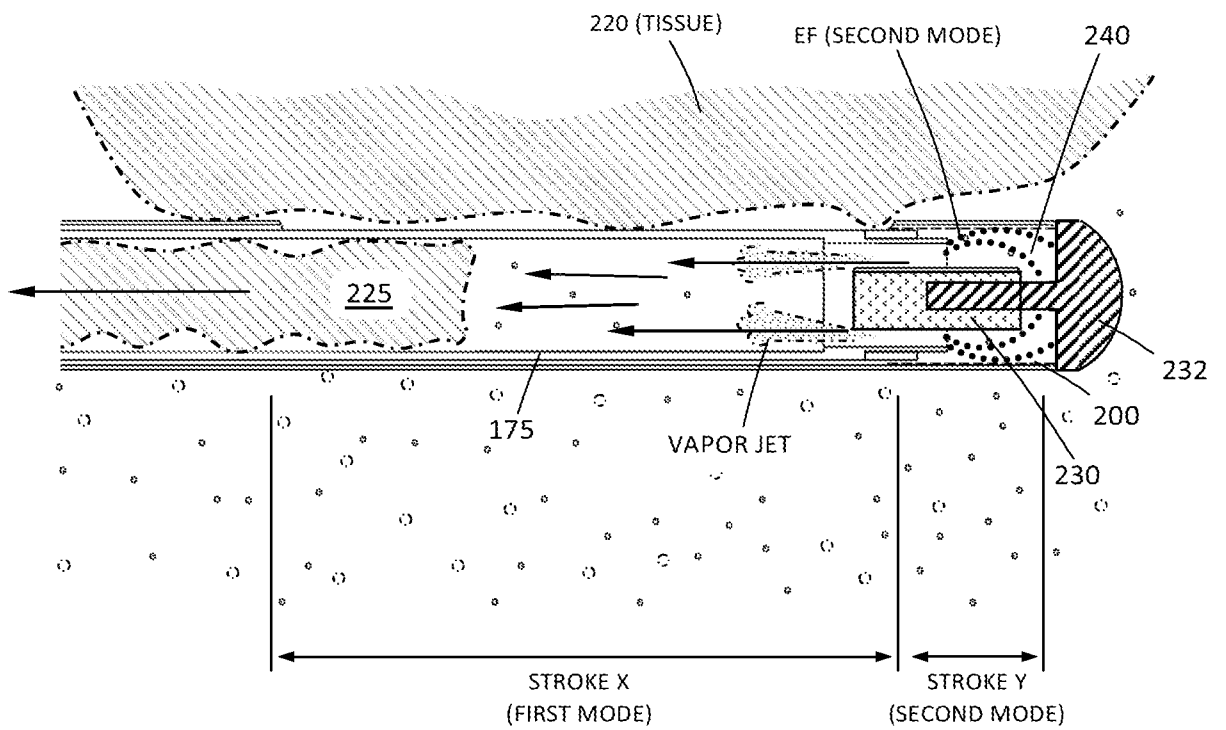

FIG. 12C

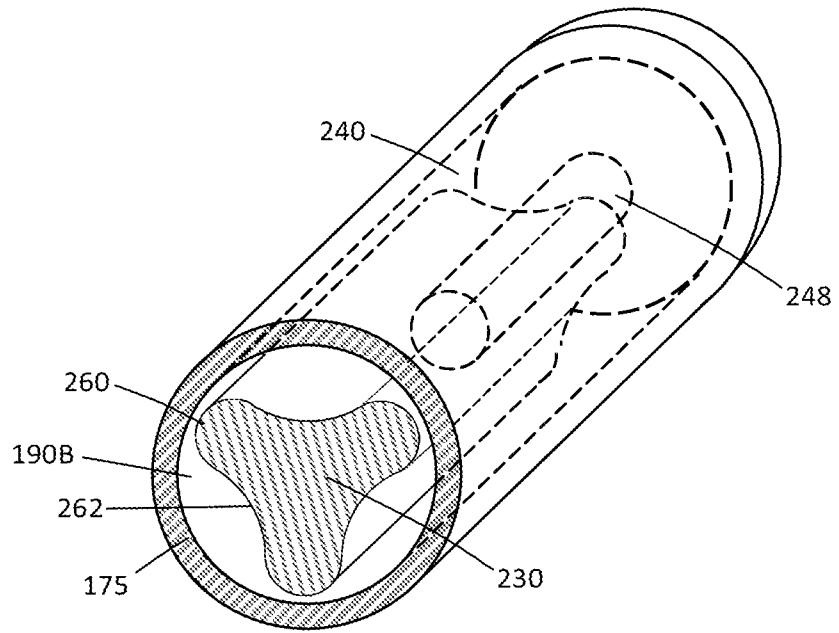

FIG. 13

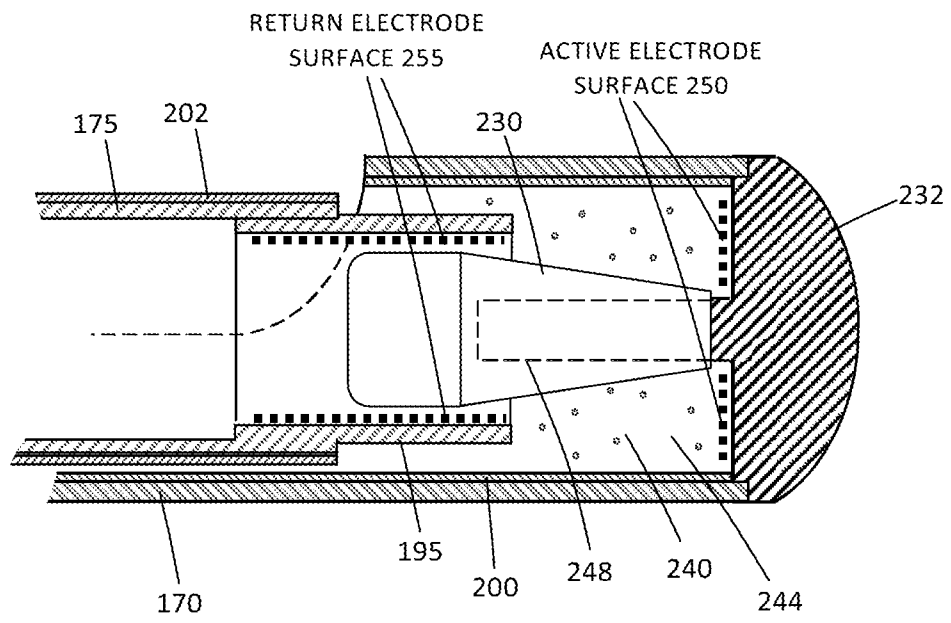

FIG. 14

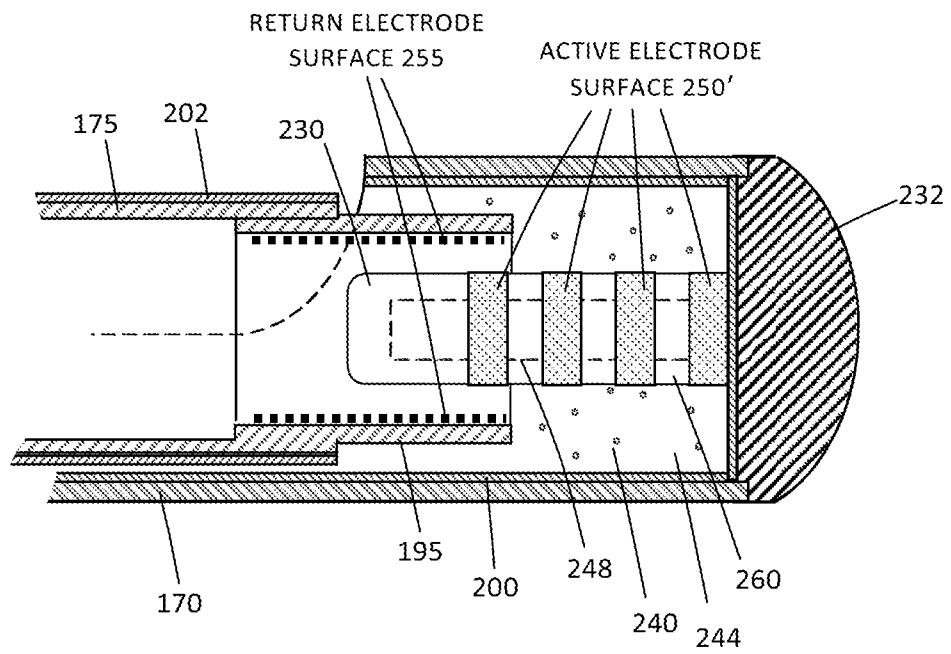

FIG. 15

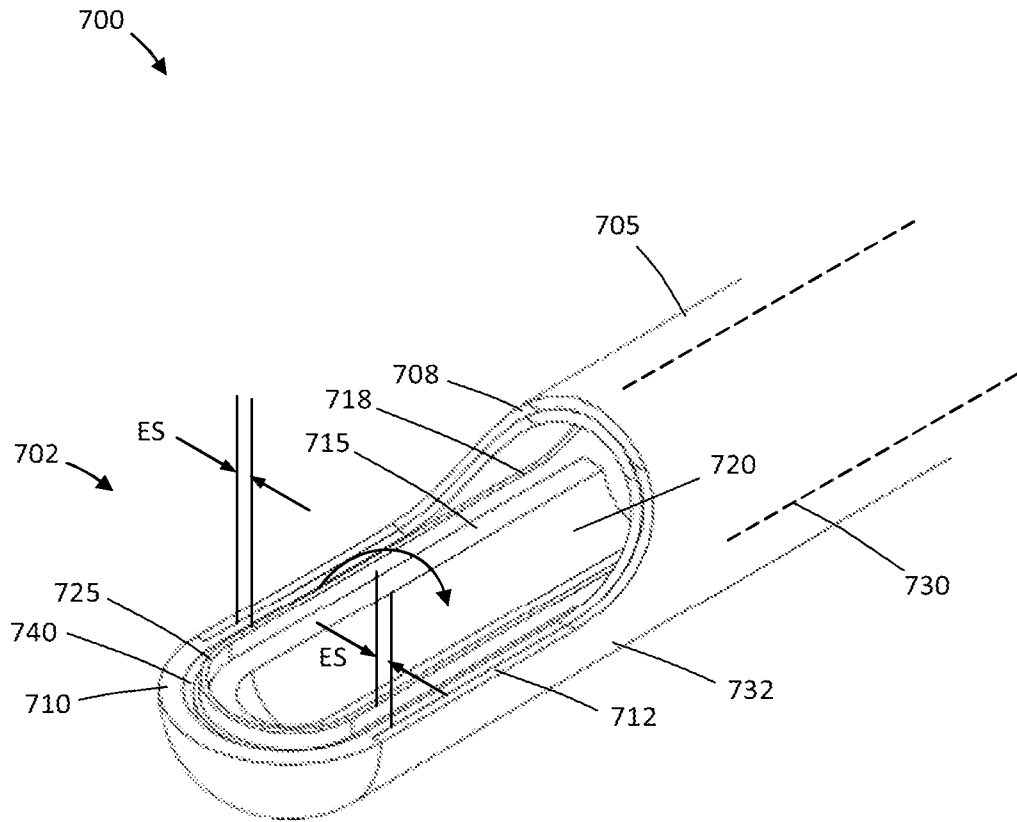

FIG. 16A

18/29

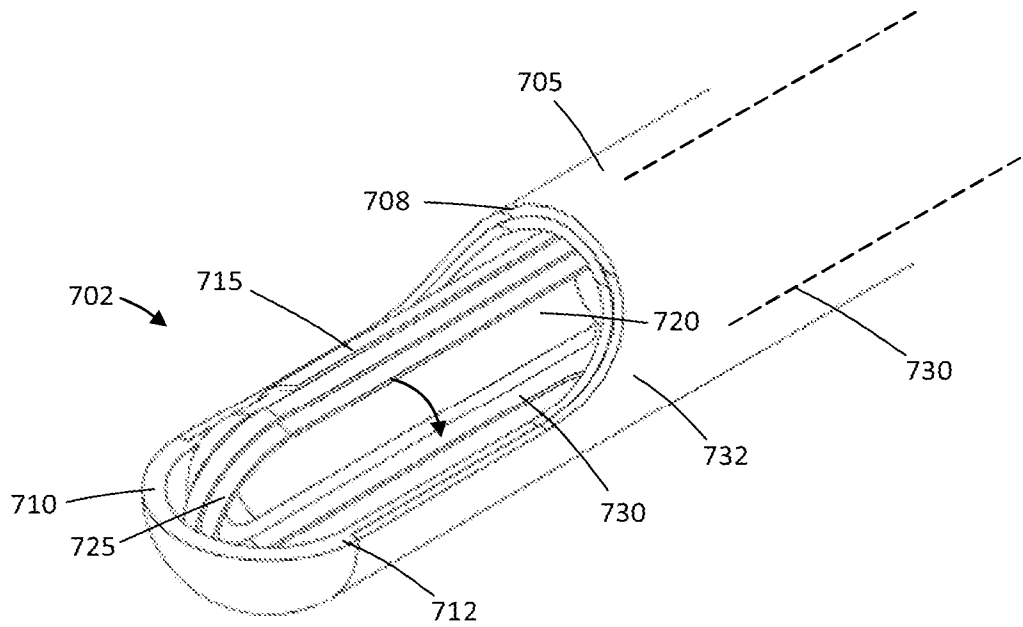

FIG. 16B

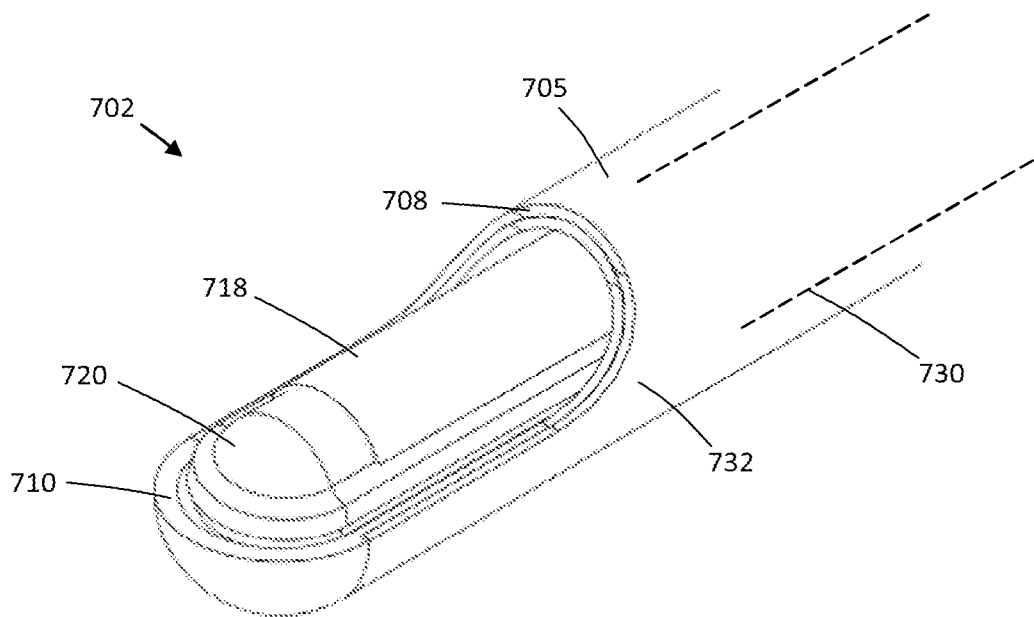

FIG. 16C

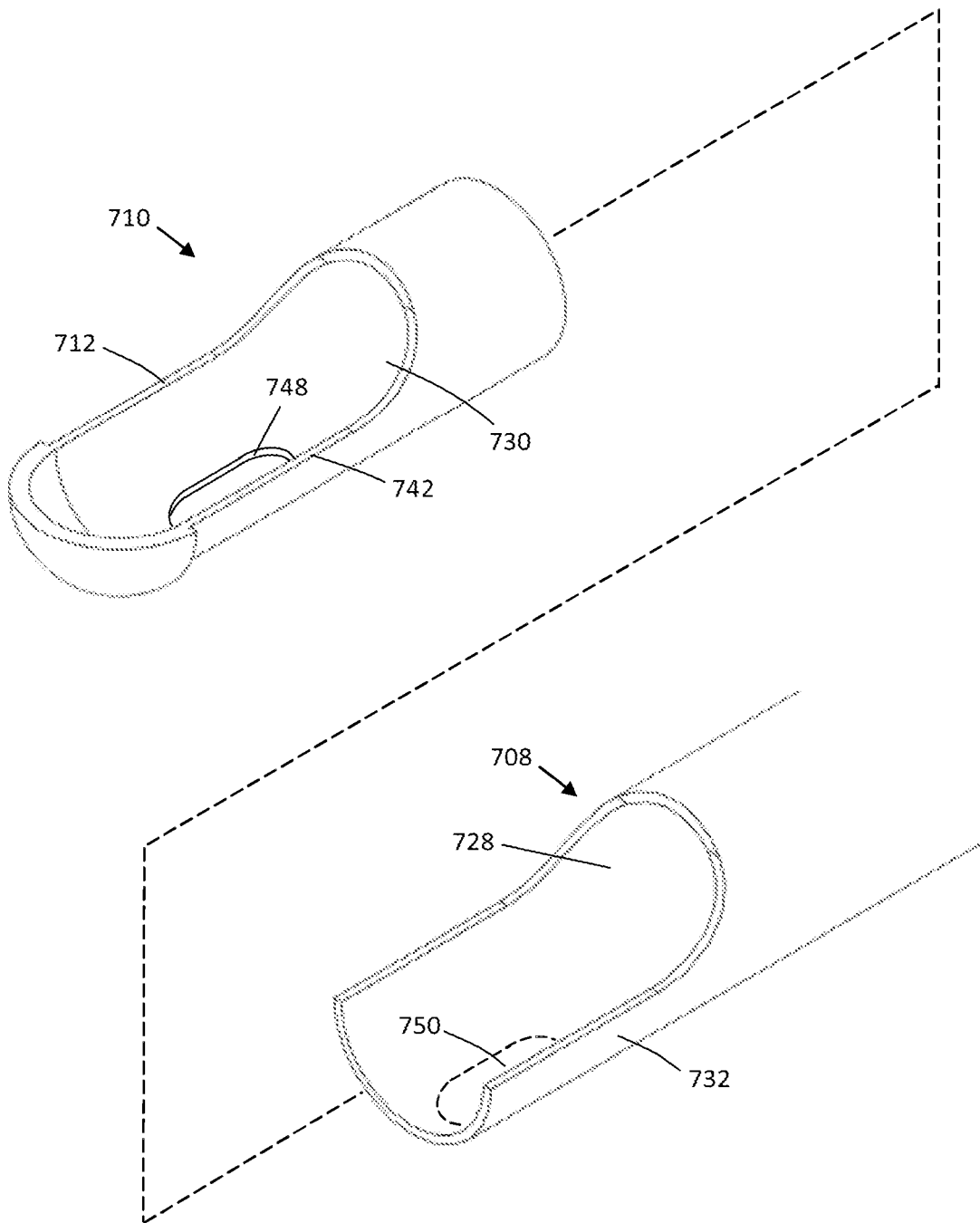

FIG. 17

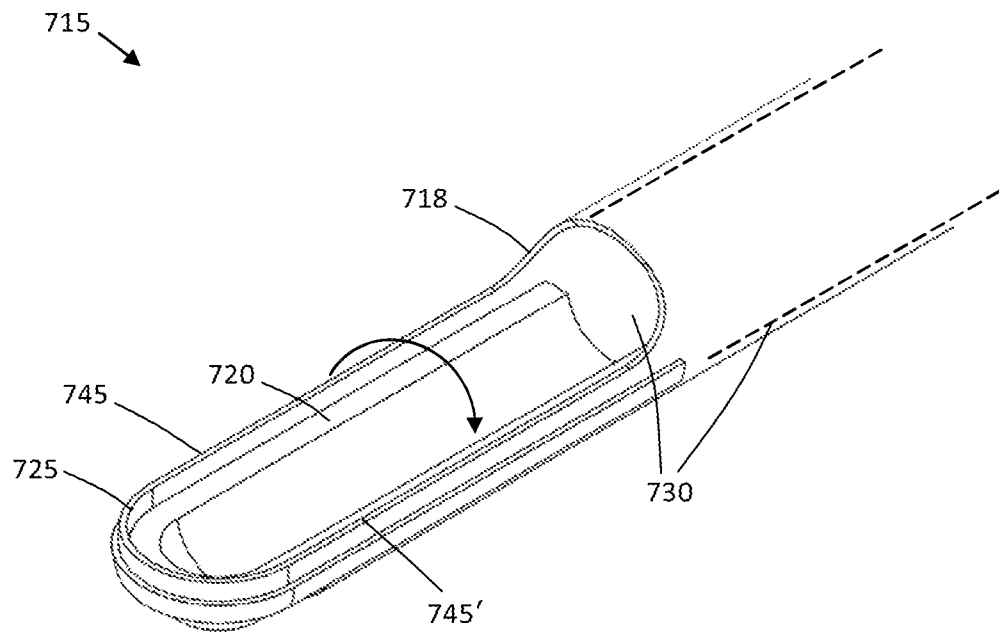

FIG. 18

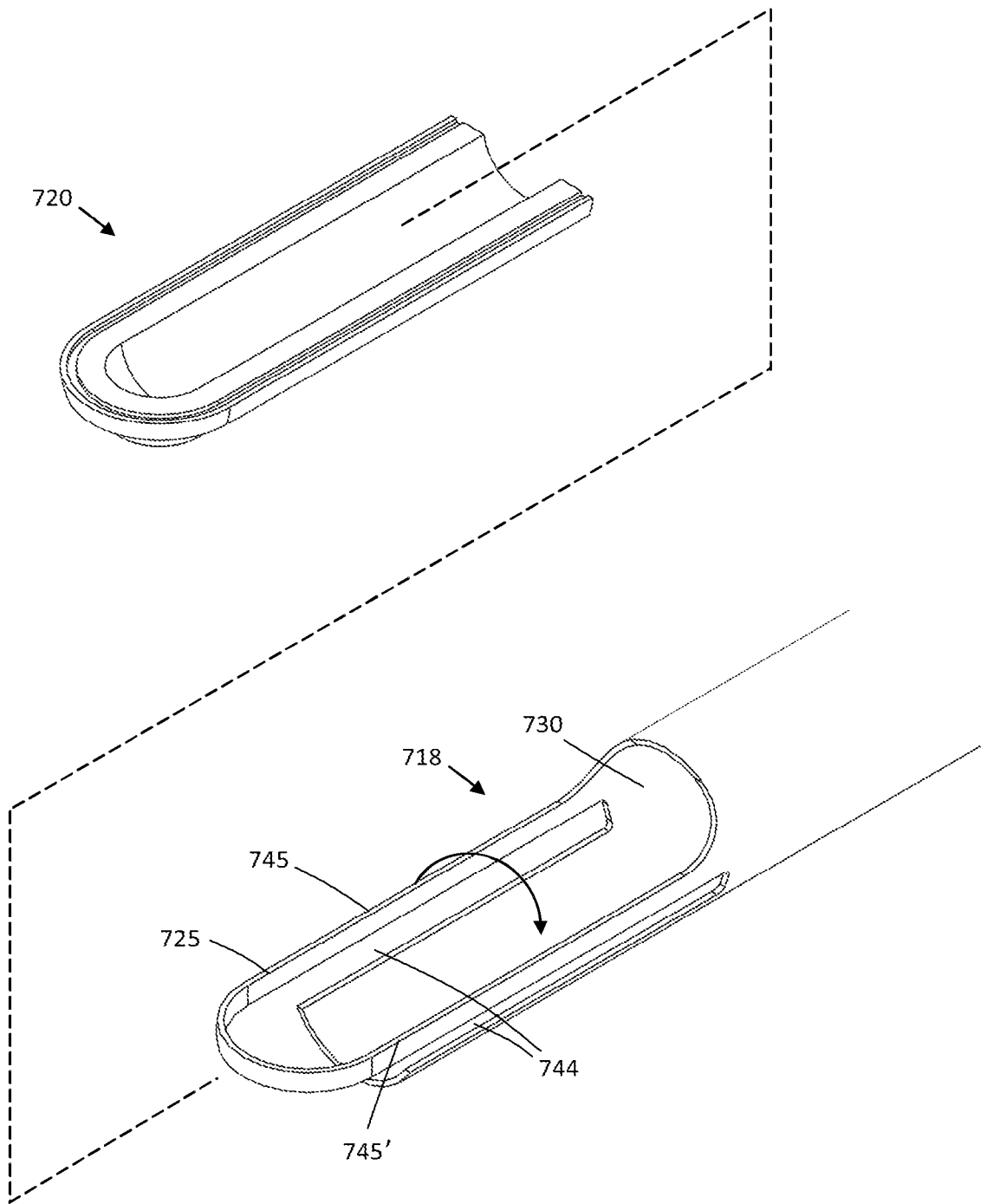

FIG. 19

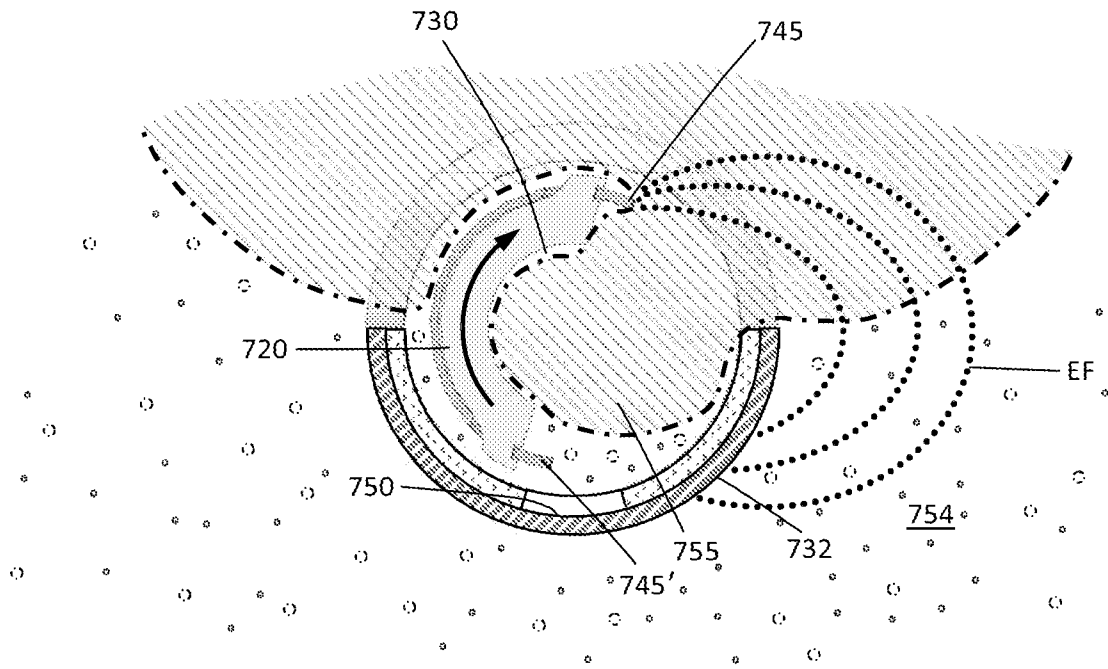

FIG. 20A

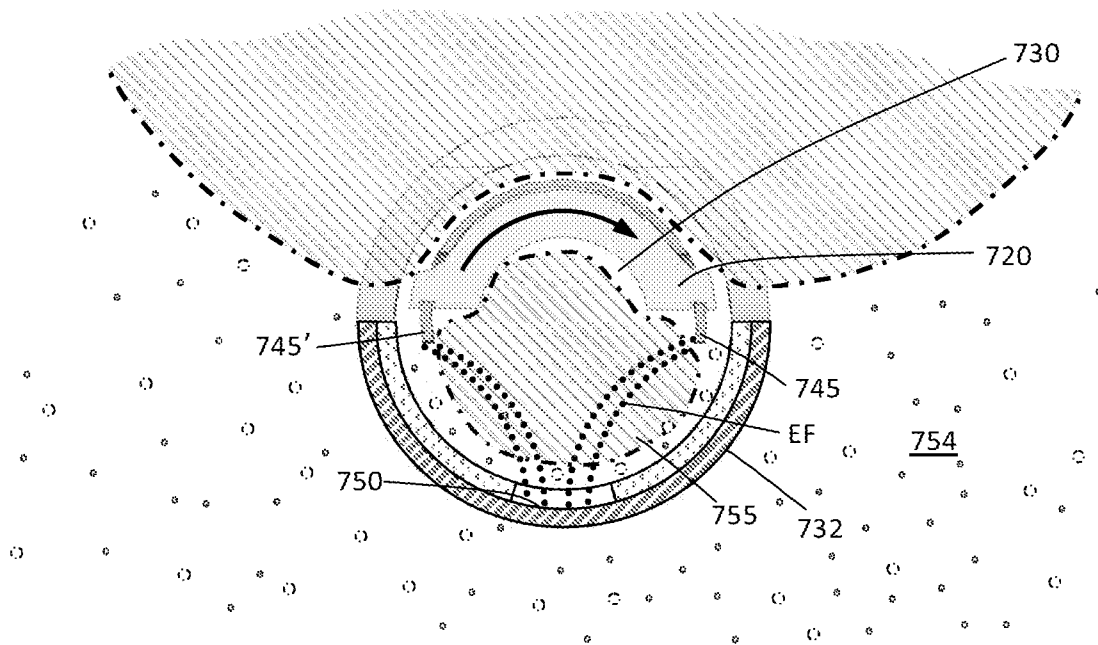

FIG. 20B

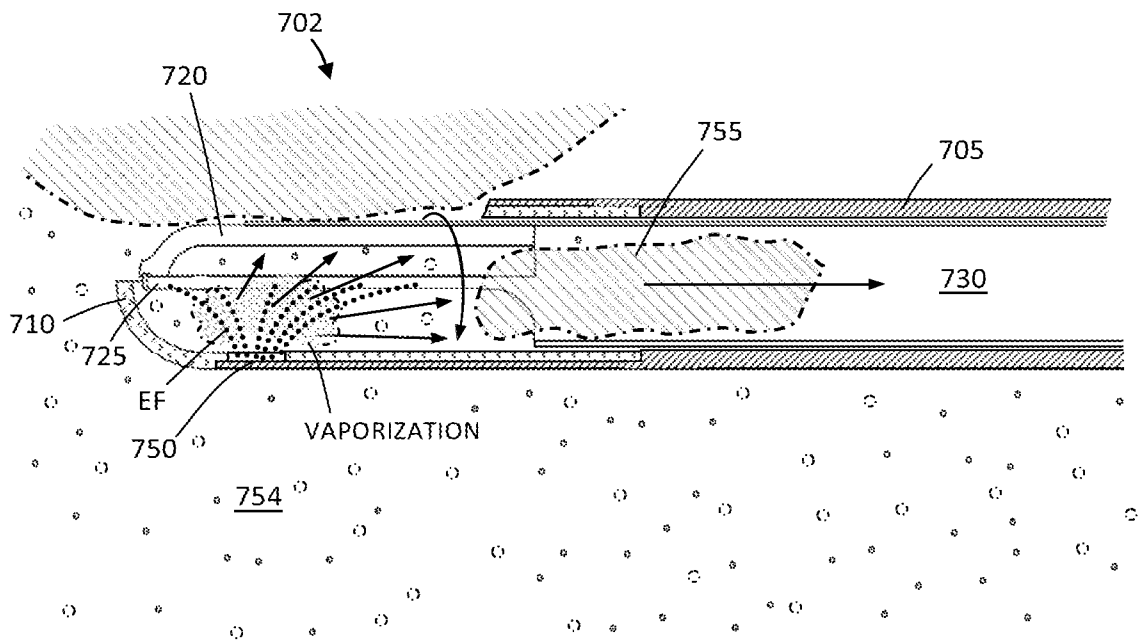

FIG. 21

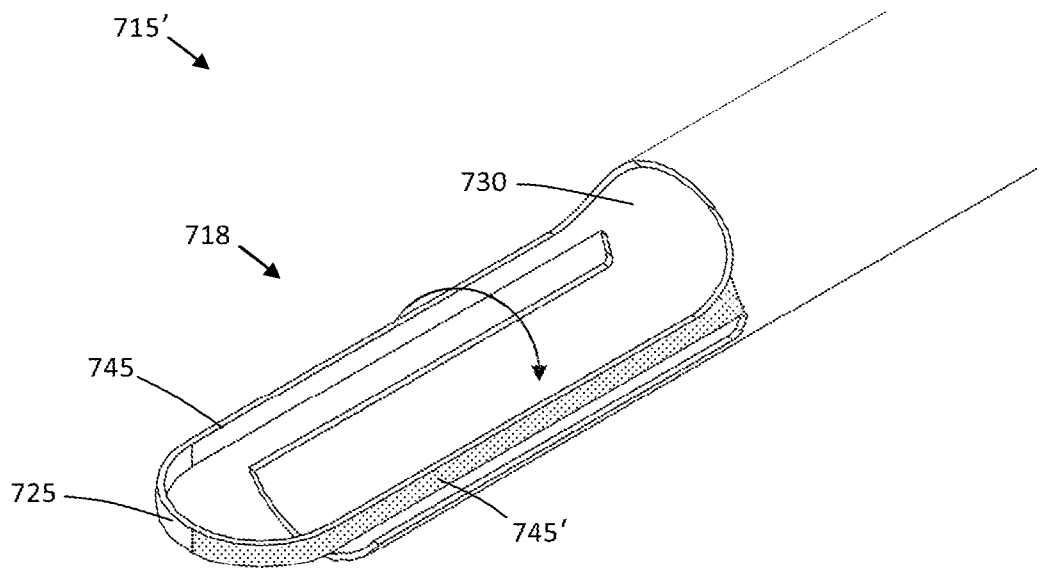

FIG. 22

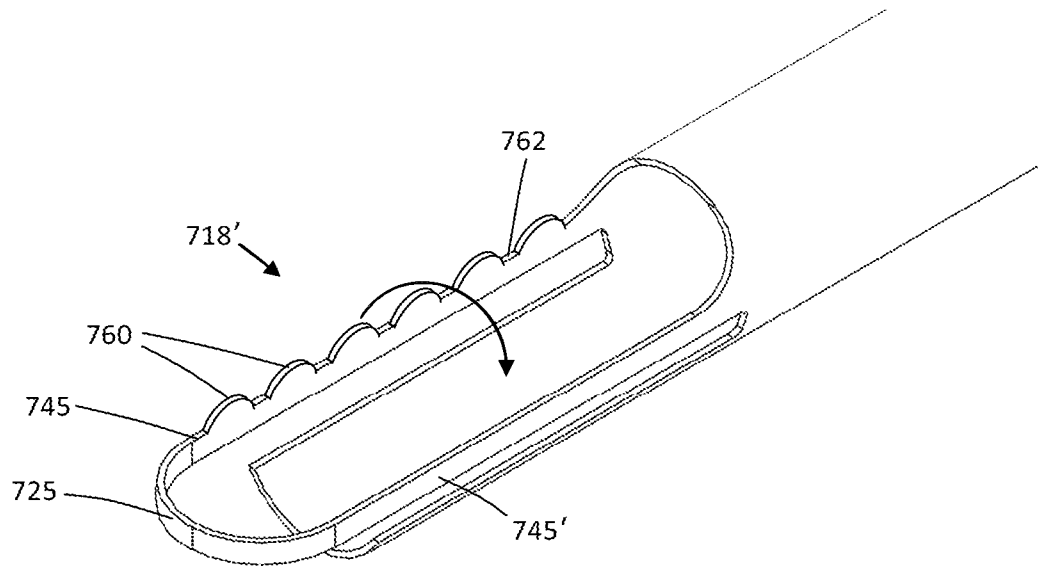

FIG. 23

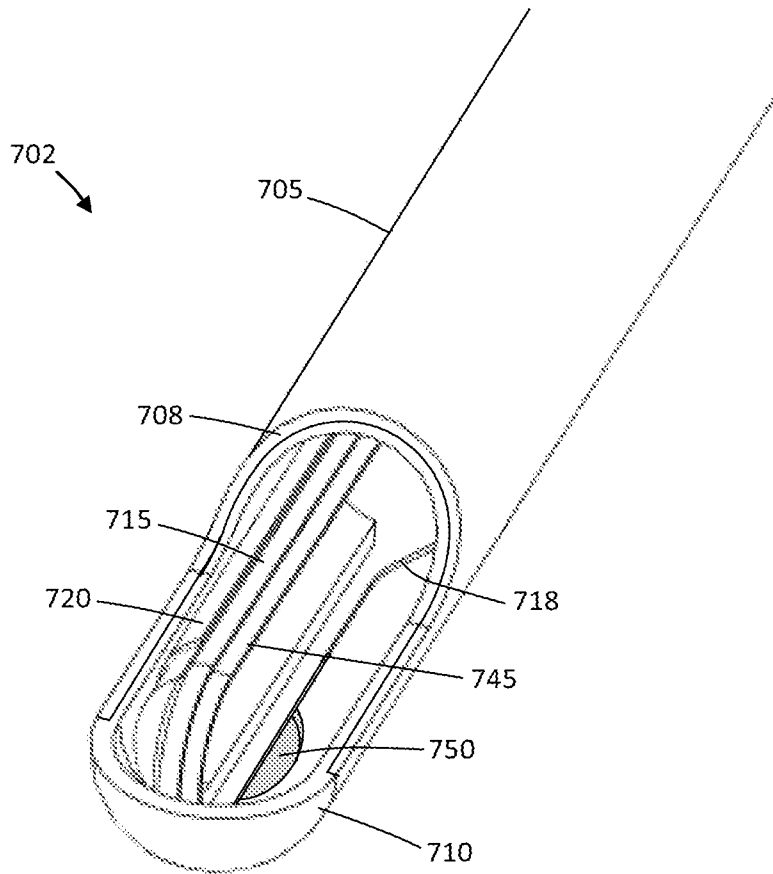

FIG. 24

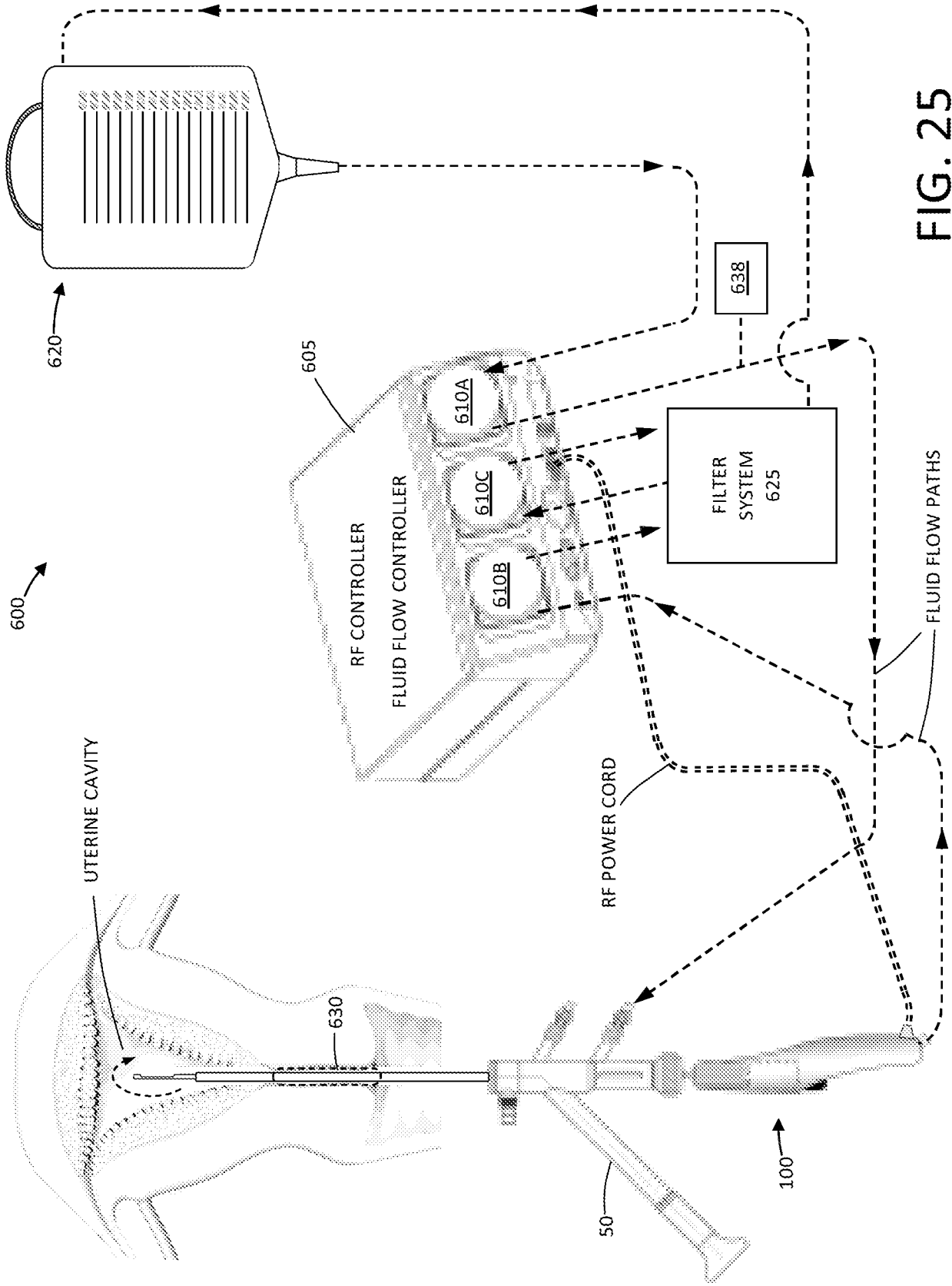

FIG. 25

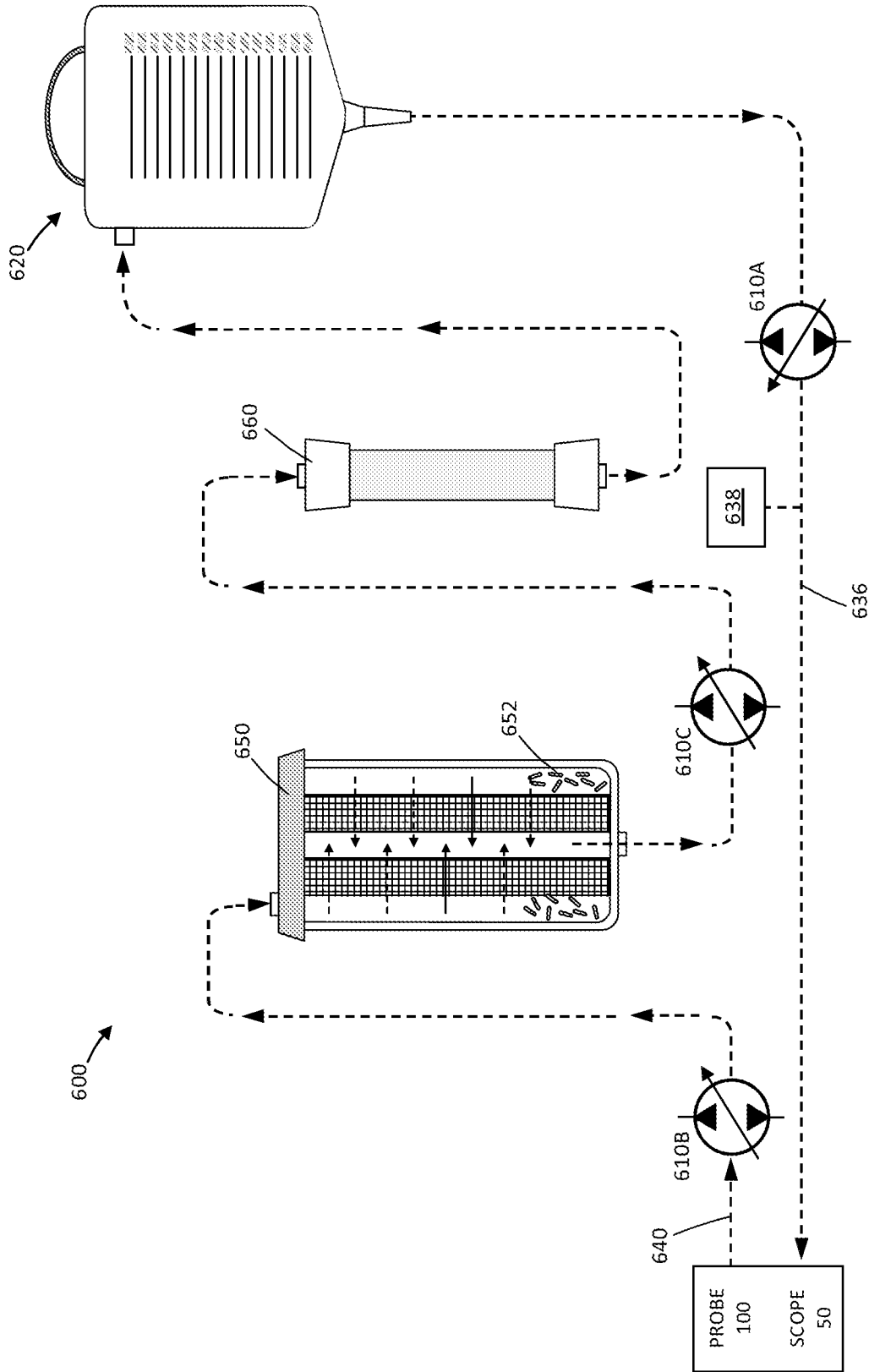

FIG. 26

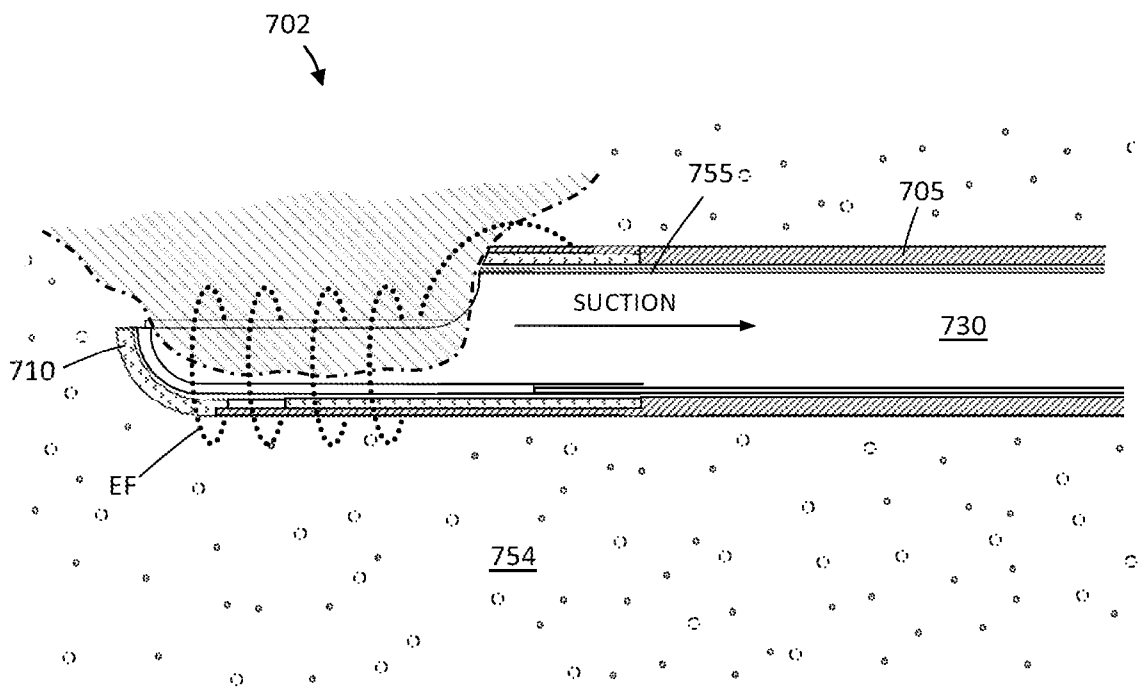

FIG. 27

A. CLASSIFICATION OF SUBJECT MATTER*A61B 18/12(2006.01)i, A61B 17/34(2006.01)i, A61M 3/04(2006.01)i, A61B 17/42(2006.01)i, A61M 31/00(2006.01)i*

According to International Patent Classification (IPC) or to both national classification and IPC

B. FIELDS SEARCHED

Minimum documentation searched (classification system followed by classification symbols)

A61B 18/12; A61B 18/14; A61B 18/18; A61F 7/00

Documentation searched other than minimum documentation to the extent that such documents are included in the fields searched

Korean utility models and applications for utility models

Japanese utility models and applications for utility models

Electronic data base consulted during the international search (name of data base and, where practicable, search terms used)

eKOMPASS(KIPO internal) & keywords: tissue extraction, RF cutting component, radio frequency, RF electrode, fluid flow, peristaltic pump, controller

C. DOCUMENTS CONSIDERED TO BE RELEVANT

Category*	Citation of document, with indication, where appropriate, of the relevant passages	Relevant to claim No.
X	US 2007-0016182 A1 (LIPSON, D. et al.) 18 January 2007	1,3-5,14-17
Y	See paragraphs [0003], [0006], [0007], [0014], [0017], [0079], [0086], [0087], [0144], [0182]; figures 2, 3, 4.	2,12,13
A		6-11,18-22
Y	US 2004-0102770 A1 (GOBLE, N. M.) 27 May 2004	2,12,13
A	See paragraph [0121], claims 1, 6, 26, 34, figures 1, 10.	1,3-11,14-22
A	US 2003-0060862 A1 (GOBLE, C. C. O. et al.) 27 March 2003	1-22
	See abstract, claim 7, figures 1, 2.	
A	US 2004-0267255 A1 (AUGE II, W. K. et al.) 30 December 2004	1-22
	See claims 6, 16, 36, figure 2.	
A	US 2002-0010463 A1 (MULIER, P. M. J. et al.) 24 January 2002	1-22
	See abstract, claims 1, 2, figure 1.	
A	US 6109268 A (THAPLIYAL, HIRA V. et al.) 29 August 2000	1-22
	See abstract, column 16, line 56 - column 17, line 14, figure 1.	

 Further documents are listed in the continuation of Box C. See patent family annex.

* Special categories of cited documents:

"A" document defining the general state of the art which is not considered to be of particular relevance

"E" earlier application or patent but published on or after the international filing date

"L" document which may throw doubts on priority claim(s) or which is cited to establish the publication date of citation or other special reason (as specified)

"O" document referring to an oral disclosure, use, exhibition or other means

"P" document published prior to the international filing date but later than the priority date claimed

"T" later document published after the international filing date or priority date and not in conflict with the application but cited to understand the principle or theory underlying the invention

"X" document of particular relevance; the claimed invention cannot be considered novel or cannot be considered to involve an inventive step when the document is taken alone

"Y" document of particular relevance; the claimed invention cannot be considered to involve an inventive step when the document is combined with one or more other such documents, such combination being obvious to a person skilled in the art

"&" document member of the same patent family

Date of the actual completion of the international search

12 MARCH 2013 (12.03.2013)

Date of mailing of the international search report

13 MARCH 2013 (13.03.2013)

Name and mailing address of the ISA/KR

Korean Intellectual Property Office
189 Cheongsu-ro, Seo-gu, Daejeon Metropolitan
City, 302-701, Republic of Korea

Facsimile No. 82-42-472-7140

Authorized officer

HAN, In Ho

Telephone No. 82-42-481-3362



INTERNATIONAL SEARCH REPORT

Information on patent family members

International application No.

PCT/US2012/063406

Patent document cited in search report	Publication date	Patent family member(s)	Publication date
US 2007-0016182 A1	18.01.2007	AU 2001-39987 A1	17.09.2001
		AU 2001-92972 A1	02.04.2002
		AU 2002-339884 A8	18.03.2003
		AU 2003-220598 A1	13.10.2003
		AU 2003-239473 A1	02.12.2003
		EP 1263341 A2	11.12.2002
		EP 1263341 B1	11.06.2008
		EP 1318758 A1	18.06.2003
		EP 1318758 B1	15.04.2009
		EP 1435865 A2	14.07.2004
		EP 1435867 A1	14.07.2004
		EP 1435867 B1	17.11.2010
		EP 1487365 A1	22.12.2004
		EP 1503687 A2	09.02.2005
		EP 1827275 A2	05.09.2007
		EP 1827275 B1	10.08.2011
		EP 1946716 A1	23.07.2008
		EP 2011446 A2	07.01.2009
		EP 2011446 A3	25.02.2009
		EP 2275050 A1	19.01.2011
		EP 2305160 A1	06.04.2011
		JP 2004-500207 A	08.01.2004
		JP 2004-508875 A	25.03.2004
		JP 2005-501609 A	20.01.2005
		JP 2005-502424 A	27.01.2005
		JP 2005-521465 A	21.07.2005
		JP 2005-525861 A	02.09.2005
		JP 2008-520382 A	19.06.2008
		JP 2011-156383 A	18.08.2011
		US 2001-0032002 A1	18.10.2001
		US 2002-0062123 A1	23.05.2002
		US 2002-0128650 A1	12.09.2002
		US 2003-0114850 A1	19.06.2003
		US 2003-0216733 A1	20.11.2003
		US 2004-0019350 A1	29.01.2004
		US 2004-0138655 A1	15.07.2004
		US 2004-0162552 A1	19.08.2004
		US 2005-0010212 A1	13.01.2005
		US 2005-0015085 A1	20.01.2005
		US 2005-0033278 A1	10.02.2005
		US 2005-0059966 A1	17.03.2005
		US 2005-0090816 A1	28.04.2005
		US 2006-0100619 A1	11.05.2006
		US 2006-0106379 A1	18.05.2006
		US 2006-0116675 A1	01.06.2006
		US 2006-0149225 A1	06.07.2006
		US 2007-0049920 A1	01.03.2007
		US 2008-0058796 A1	06.03.2008
		US 2009-0264879 A1	22.10.2009

INTERNATIONAL SEARCH REPORT

Information on patent family members

International application No.

PCT/US2012/063406

Patent document cited in search report	Publication date	Patent family member(s)	Publication date
		US 2010-0100095 A1	22.04.2010
		US 2011-0028965 A1	03.02.2011
		US 6558385 B1	06.05.2003
		US 6689131 B2	10.02.2004
		US 6702810 B2	09.03.2004
		US 6953461 B2	11.10.2005
		US 7115139 B2	03.10.2006
		US 7604635 B2	20.10.2009
		US 7645277 B2	12.01.2010
		US 7651494 B2	26.01.2010
		US 7811282 B2	12.10.2010
		US 7815634 B2	19.10.2010
		US 7909820 B2	22.03.2011
		US 7951148 B2	31.05.2011
		US 7976544 B2	12.07.2011
		US 7998140 B2	16.08.2011
		US 8038670 B2	18.10.2011
		US 8048070 B2	01.11.2011
		US 8361068 B2	29.01.2013
		WO 02-071966 A1	19.09.2002
		WO 03-020339 A2	13.03.2003
		WO 03-024349 A1	27.03.2003
		WO 03-082134 A1	09.10.2003
		WO 03-096880 A2	27.11.2003
		WO 2004-080278 A2	23.09.2004
		WO 2004-080278 A3	04.11.2004
		WO 2006-057966 A2	01.06.2006
US 2004-0102770 A1	27.05.2004	AU 1998-83497 B2	29.03.2001
		AU 1998-83498 B2	10.05.2001
		AU 1998-83508 B2	05.04.2001
		AU 2000-19910 A1	01.08.2000
		CA 2297075 A1	28.01.1999
		CA 2297078 A1	28.01.1999
		CA 2297081 A1	28.01.1999
		CN 1336812 A0	20.02.2002
		EP 0923907 A1	23.06.1999
		EP 0996376 A1	03.05.2000
		EP 0996377 A1	03.05.2000
		EP 0996378 A1	03.05.2000
		EP 0996378 B1	30.06.2004
		EP 1139895 A1	10.10.2001
		GB 2327350 A	27.01.1999
		GB 2327351 A	27.01.1999
		GB 2327352 A	27.01.1999
		JP 11-244298 A	14.09.1999
		JP 2001-510066 A	31.07.2001
		JP 2001-510067 A	31.07.2001
		JP 2001-510068 A	31.07.2001
		KR 10-2001-0021980 A	15.03.2001

INTERNATIONAL SEARCH REPORT

Information on patent family members

International application No.

PCT/US2012/063406

Patent document cited in search report	Publication date	Patent family member(s)	Publication date
		KR 10-2001-0021982 A	15.03.2001
		KR 10-2001-0021983 A	15.03.2001
		US 2002-0095150 A1	18.07.2002
		US 2004-0030333 A1	12.02.2004
		US 2005-0090819 A1	28.04.2005
		US 6336926 B1	08.01.2002
		US 6565560 B1	20.05.2003
		US 6923803 B2	02.08.2005
		US 7001380 B2	21.02.2006
		US 7278994 B2	09.10.2007
		WO 00-41638 A1	20.07.2000
		WO 99-03407 A1	28.01.1999
		WO 99-03408 A1	28.01.1999
		WO 99-03409 A1	28.01.1999
US 2003-0060862 A1	27.03.2003	EP 1427340 A1	16.06.2004
		EP 1427340 B1	18.08.2010
		GB 2379878 A	26.03.2003
		GB 2379878 B	10.11.2004
		US 7052494 B2	30.05.2006
		WO 03-024339 A1	27.03.2003
US 2004-0267255 A1	30.12.2004	AU 2002-316304 A8	02.01.2003
		AU 2002-335647 A8	03.03.2003
		AU 2003-243456 A1	22.12.2003
		AU 2003-243534 A1	22.12.2003
		CA 2736704 A1	08.10.2011
		EP 2374426 A1	12.10.2011
		EP 2442716 A2	25.04.2012
		EP 2488123 A2	22.08.2012
		US 2002-0022846 A1	21.02.2002
		US 2003-0036753 A1	20.02.2003
		US 2003-0175251 A1	18.09.2003
		US 2004-0167244 A1	26.08.2004
		US 2005-0182449 A1	18.08.2005
		US 2005-0187542 A1	25.08.2005
		US 2005-0228369 A1	13.10.2005
		US 2007-0293852 A1	20.12.2007
		US 2009-0030410 A1	29.01.2009
		US 2009-0306645 A1	10.12.2009
		US 2010-0069975 A1	18.03.2010
		US 2010-0087815 A1	08.04.2010
		US 2010-0262136 A1	14.10.2010
		US 2010-0324550 A1	23.12.2010
		US 2011-0034914 A1	10.02.2011
		US 2011-0087308 A1	14.04.2011
		US 2011-0288547 A1	24.11.2011
		US 6547794 B2	15.04.2003
		US 6902564 B2	07.06.2005
		US 7066932 B1	27.06.2006

INTERNATIONAL SEARCH REPORT

Information on patent family members

International application No.

PCT/US2012/063406

Patent document cited in search report	Publication date	Patent family member(s)	Publication date
		US 7105011 B2	12.09.2006
		US 7354438 B2	08.04.2008
		US 7445619 B2	04.11.2008
		US 7549989 B2	23.06.2009
		US 7713269 B2	11.05.2010
		US 7771422 B2	10.08.2010
		US 7819861 B2	26.10.2010
		US 7819864 B2	26.10.2010
		US 7955296 B1	07.06.2011
		US 8235979 B2	07.08.2012
		WO 02-102438 A2	27.12.2002
		WO 03-015865 A2	27.02.2003
		WO 03-103521 A1	18.12.2003
		WO 03-103522 A1	18.12.2003
		WO 2010-148199 A2	23.12.2010
		WO 2011-047148 A3	21.04.2011
US 2002-0010463 A1	24.01.2002	AU 697542 B2	08.10.1998
		AU 7514096 A	22.05.1997
		CA 2234676 A1	09.05.1997
		CA 2376365 A1	09.05.1997
		EP 1245196 A1	02.10.2002
		EP 1245196 B1	02.01.2004
		EP 1411846 A1	28.04.2004
		EP 1450712 A1	01.09.2004
		EP 1450712 B1	04.05.2011
		EP 2204133 A1	07.07.2010
		US 2001-0051804 A1	13.12.2001
		US 2002-0058933 A1	16.05.2002
		US 2002-0151884 A1	17.10.2002
		US 2003-0073989 A1	17.04.2003
		US 2004-0092926 A1	13.05.2004
		US 2004-0215183 A1	28.10.2004
		US 2004-0236324 A1	25.11.2004
		US 2006-0074414 A1	06.04.2006
		US 2007-0118114 A1	24.05.2007
		US 2007-0208332 A1	06.09.2007
		US 2008-0015563 A1	17.01.2008
		US 2008-0300593 A1	04.12.2008
		US 6328736 B1	11.12.2001
		US 6358248 B1	19.03.2002
		US 6409722 B1	25.06.2002
		US 6475216 B2	05.11.2002
		US 6537272 B2	25.03.2003
		US 6585732 B2	01.07.2003
		US 6716211 B2	06.04.2004
		US 6736810 B2	18.05.2004
		US 6764487 B2	20.07.2004
		US 6849073 B2	01.02.2005
		US 6949098 B2	27.09.2005

INTERNATIONAL SEARCH REPORT

Information on patent family members

International application No.

PCT/US2012/063406

Patent document cited in search report	Publication date	Patent family member(s)	Publication date
		US 7166105 B2	23.01.2007
		US 7169144 B2	30.01.2007
		US 7247155 B2	24.07.2007
		US 7364579 B2	29.04.2008
		US 7422588 B2	09.09.2008
		US 7794460 B2	14.09.2010
		WO 03-005918 A1	23.01.2003
		WO 03-047446 A1	12.06.2003
US 06109268 A	29.08.2000	AU 1996-60266 B2	10.06.1999
		AU 1997-10545 B2	04.03.1999
		AU 1997-10571 B2	09.09.1999
		AU 1997-24724 B2	07.10.1999
		AU 1998-97829 A1	27.04.1999
		AU 1999-11124 A1	10.05.1999
		AU 1999-11940 A1	10.05.1999
		AU 1999-14640 A1	15.06.1999
		AU 1999-19990 A1	05.07.1999
		AU 1999-32961 A1	06.09.1999
		AU 1999-39758 A1	23.11.1999
		AU 1999-48429 A1	17.01.2000
		AU 1999-52554 A1	28.02.2000
		AU 1999-57736 A1	06.03.2000
		AU 2000-16334 A1	19.06.2000
		AU 2000-39129 A1	09.10.2000
		AU 2000-42233 A1	02.11.2000
		AU 2000-46507 A1	02.11.2000
		AU 2000-51429 A1	12.12.2000
		AU 2001-43151 A1	27.08.2001
		AU 2001-61637 A1	18.02.2002
		AU 2001-61726 A1	24.12.2001
		CA 2129745 A1	08.07.1993
		CA 2162395 A1	24.11.1994
		CA 2221330 A1	19.12.1996
		CA 2237947 A1	29.05.1997
		CA 2287206 A1	17.12.1998
		CA 2318891 A1	26.08.1999
		CN 1187820 A0	15.07.1998
		EP 0624076 A1	28.10.1998
		EP 0624076 B1	02.12.1998
		EP 0917482 A1	05.01.2005
		EP 0917482 A4	22.12.1999
		EP 0917482 B1	09.09.2009
		EP 0921759 A1	07.02.2001
		EP 0921759 B1	31.08.2011
		EP 0998248 A1	10.05.2000
		EP 1009343 A1	21.06.2000
		EP 1018994 A1	19.07.2000
		EP 1018994 B1	21.09.2005
		EP 1024769 A1	09.08.2000

INTERNATIONAL SEARCH REPORT

Information on patent family members

International application No.

PCT/US2012/063406

Patent document cited in search report	Publication date	Patent family member(s)	Publication date
		EP 1024769 B1	25.02.2009
		EP 1026996 A1	16.08.2000
		EP 1026996 B1	10.10.2007
		EP 1027020 A1	16.08.2000
		EP 1027020 A4	21.11.2001
		EP 1027020 B1	16.11.2005
		EP 1036547 A2	20.09.2000
		EP 1036547 A3	27.12.2000
		EP 1039862 A1	04.10.2000
		EP 1039862 B1	21.05.2008
		EP 1041933 A1	11.10.2000
		EP 1041933 A4	27.12.2000
		EP 1041933 B1	31.03.2004
		EP 1061857 A1	27.12.2000
		EP 1061857 A4	21.11.2001
		EP 1061857 B1	19.12.2007
		EP 1079746 A1	07.03.2001
		EP 1079746 B1	21.03.2007
		EP 1080680 A1	07.03.2001
		EP 1080682 A1	07.03.2001
		EP 1080682 B1	08.07.2009
		EP 1174093 A1	23.01.2002
		EP 1178757 A1	13.02.2002
		EP 1178758 A1	13.02.2002
		EP 1178758 B1	27.10.2010
		EP 1179320 A2	13.02.2002
		EP 1179320 A3	03.12.2003
		EP 1187570 A1	20.03.2002
		EP 1257221 A1	20.11.2002
		EP 1289438 A1	12.03.2003
		EP 1309282 A1	14.05.2003
		EP 1309282 A4	08.03.2006
		EP 1404236 A1	07.04.2004
		EP 1404236 A4	05.01.2005
		EP 1404236 B1	14.09.2011
		EP 1411847 A2	28.04.2004
		EP 1411847 B1	06.06.2012
		EP 1503688 A1	09.02.2005
		EP 1571969 A2	14.09.2005
		EP 1571969 A3	21.09.2005
		EP 1571969 A4	05.07.2006
		EP 1571969 B1	08.02.2012
		EP 1637087 A2	22.03.2006
		EP 1637087 A3	10.05.2006
		EP 1637087 B1	10.08.2011
		EP 1880686 A2	23.01.2008
		EP 1880686 A3	26.01.2011
		EP 2055253 A2	06.05.2009
		EP 2055253 A3	03.02.2010
		EP 2055254 A2	06.05.2009

INTERNATIONAL SEARCH REPORT

Information on patent family members

International application No.

PCT/US2012/063406

Patent document cited in search report	Publication date	Patent family member(s)	Publication date
		EP 2055254 A3	10.02.2010
		EP 2057954 A1	13.05.2009
		EP 2057954 B1	16.03.2011
		JP 2000-060868 A	29.02.2000
		JP 2000-515798 A	28.11.2000
		JP 2001-513395 A	04.09.2001
		JP 2001-518352 A	16.10.2001
		JP 2001-520081 A	30.10.2001
		JP 2001-522252 A	13.11.2001
		JP 2001-523513 A	27.11.2001
		JP 2002-503508 A	05.02.2002
		JP 2002-508214 A	19.03.2002
		JP 2002-513619 A	14.05.2002
		JP 2002-514097 A	14.05.2002
		JP 2002-541902 A	10.12.2002
		JP 2002-541904 A	10.12.2002
		JP 2003-500099 A	07.01.2003
		JP 2003-527875 A	24.09.2003
		JP 2004-505663 A	26.02.2004
		JP 2008-220988 A	25.09.2008
		JP 2008-296034 A	11.12.2008
		JP 2011-045756 A	10.03.2011
		JP 4713613 B2	29.06.2011
		JP 4756179 B2	24.08.2011
		KR 10-1998-0703800 A	05.12.1998
		US 05366443 A	22.11.1994
		US 05419767 A	30.05.1995
		US 05681282 A	28.10.1997
		US 05683366 A	04.11.1997
		US 05697281 A	16.12.1997
		US 05697536 A	16.12.1997
		US 05697882 A	16.12.1997
		US 05697909 A	16.12.1997
		US 05766153 A	16.06.1998
		US 05810764 A	22.09.1998
		US 05843019 A	01.12.1998
		US 05860951 A	19.01.1999
		US 05871469 A	16.02.1999
		US 05873855 A	23.02.1999
		US 05888198 A	30.03.1999
		US 05891095 A	06.04.1999
		US 05902272 A	11.05.1999
		US 05925663 A	20.07.1999
		US 05941722 A	24.08.1999
		US 06024733 A	15.02.2000
		US 06032674 A	07.03.2000
		US 06045532 A	04.04.2000
		US 06053172 A	25.04.2000
		US 06063079 A	16.05.2000
		US 06066134 A	23.05.2000

INTERNATIONAL SEARCH REPORT

Information on patent family members

International application No.

PCT/US2012/063406

Patent document cited in search report	Publication date	Patent family member(s)	Publication date
		US 06080776 A	27.06.2000
		US 06086585 A	11.07.2000
		US 06102046 A	15.08.2000
		US 06105581 A	22.08.2000
		US 06109268 A	29.08.2000
		US 06113597 A	05.09.2000
		US 06117109 A	12.09.2000
		US 06142992 A	07.11.2000
		US 06149620 A	21.11.2000
		US 06159194 A	12.12.2000
		US 06159208 A	12.12.2000
		US 6179824 B1	30.01.2001
		US 6179836 B1	30.01.2001
		US 6183469 B1	06.02.2001
		US 6190381 B1	20.02.2001
		US 6203542 B1	20.03.2001
		US 6210402 B1	03.04.2001
		US 6224592 B1	01.05.2001
		US 6228078 B1	08.05.2001
		US 6228082 B1	08.05.2001
		US 6235020 B1	22.05.2001
		US 6235765 B1	22.05.2001
		US 6238391 B1	29.05.2001
		US 6254600 B1	03.07.2001
		US 6264650 B1	24.07.2001
		US 6264651 B1	24.07.2001
		US 6264652 B1	24.07.2001
		US 6277112 B1	21.08.2001
		US 6283961 B1	04.09.2001
		US 6296636 B1	02.10.2001
		US 6296638 B1	02.10.2001
		US 6309387 B1	30.10.2001
		US 6312408 B1	06.11.2001
		US 6355032 B1	12.03.2002
		US 6363937 B1	02.04.2002
		US 6379351 B1	30.04.2002
		US 6391025 B1	21.05.2002
		US 6416507 B1	09.07.2002
		US 6416508 B1	09.07.2002
		US 6432103 B1	13.08.2002
		US 6461350 B1	08.10.2002
		US 6461354 B1	08.10.2002
		US 6464695 B2	15.10.2002
		US 6468270 B1	22.10.2002
		US 6468274 B1	22.10.2002
		US 6482201 B1	19.11.2002
		US 6500173 B2	31.12.2002
		US 6540741 B1	01.04.2003
		US 6544261 B2	08.04.2003
		US 6557559 B1	06.05.2003

INTERNATIONAL SEARCH REPORT

Information on patent family members

International application No.

PCT/US2012/063406

Patent document cited in search report	Publication date	Patent family member(s)	Publication date
		US 6575968 B1	10.06.2003
		US 6582423 B1	24.06.2003
		US 6589237 B2	08.07.2003
		US 6595990 B1	22.07.2003
		US 6602248 B1	05.08.2003
		US 6620155 B2	16.09.2003
		US 6623454 B1	23.09.2003
		US 6632193 B1	14.10.2003
		US 6632220 B1	14.10.2003
		US 6659106 B1	09.12.2003
		US 6712811 B2	30.03.2004
		US 6719754 B2	13.04.2004
		US 6726684 B1	27.04.2004
		US 6746447 B2	08.06.2004
		US 6749604 B1	15.06.2004
		US 6763836 B2	20.07.2004
		US 6770071 B2	03.08.2004
		US 6772012 B2	03.08.2004
		US 6773431 B2	10.08.2004
		US 6805130 B2	19.10.2004
		US 6832996 B2	21.12.2004
		US 6837887 B2	04.01.2005
		US 6837888 B2	04.01.2005
		US 6855143 B2	15.02.2005
		US 6856511 B1	15.02.2005
		US 6896672 B1	24.05.2005
		US 6896674 B1	24.05.2005
		US 6915806 B2	12.07.2005
		US 6929640 B1	16.08.2005
		US 6949096 B2	27.09.2005
		US 6960204 B2	01.11.2005
		US 6974453 B2	13.12.2005
		US 6991631 B2	31.01.2006
		US 7070596 B1	04.07.2006
		US 7090672 B2	15.08.2006
		US 7094215 B2	22.08.2006
		US 7104986 B2	12.09.2006
		US 7131969 B1	07.11.2006
		US 7169143 B2	30.01.2007
		US 7179255 B2	20.02.2007
		US 7186234 B2	06.03.2007
		US 7192428 B2	20.03.2007
		US 7201750 B1	10.04.2007