



US00D711533S

(12) **United States Design Patent**
Ting

(10) **Patent No.:** **US D711,533 S**

(45) **Date of Patent:** **** Aug. 19, 2014**

(54) **REFLEX HAMMER**

- (71) Applicant: **MDF Instruments USA, Inc.**, Agoura Hills, CA (US)
 - (72) Inventor: **Darren Talun Chiao Ting**, Malibu, CA (US)
 - (73) Assignee: **MDF Instruments USA, Inc.**, Agoura Hills, CA (US)
 - (**) Term: **14 Years**
 - (21) Appl. No.: **29/450,755**
 - (22) Filed: **Mar. 21, 2013**
 - (51) **LOC (10) Cl.** **24-02**
 - (52) **U.S. Cl.**
USPC **D24/142**
 - (58) **Field of Classification Search**
USPC D24/142; 600/552-553, 557; 601/107;
D7/682; 15/143.1, 144.3, 244.1;
181/131
- See application file for complete search history.

(56) **References Cited**

U.S. PATENT DOCUMENTS

- 1,478,388 A * 12/1923 Gray 601/107
- 1,973,768 A * 9/1934 Knapp 601/107

(Continued)

OTHER PUBLICATIONS

MDF Instruments Blood Pressure Unit Collection and Reflex Hammer Collection Brochure, dated earlier than Mar. 2012 (exact date unknown).

(Continued)

Primary Examiner — Wan Laymon

(74) *Attorney, Agent, or Firm* — The Law Office of Patrick F. O'Reilly III, LLC

(57) **CLAIM**

The ornamental design for a reflex hammer, as shown and described.

DESCRIPTION

FIG. 1 is a front-left perspective view of a reflex hammer showing my new design, wherein the telescoping handle of the reflex hammer is in an unextended state, and the rotatable head is disposed parallel to the telescoping handle; FIG. 2 is a right side elevational view thereof, an elevational view of the left side being a mirror image thereof; FIG. 3 is a front end view thereof shown at a slightly enlarged scale; FIG. 4 is a rear end view thereof shown at an enlarged scale; FIG. 5 is a top plan view thereof; FIG. 6 is a bottom plan view thereof; FIG. 7 is a partial top plan view thereof, illustrating a head locking collar in a locked position shown at an enlarged scale; FIG. 8 is a partial top plan view thereof, illustrating the head locking collar in a pulled-back position shown at an enlarged scale; FIG. 9 is a top-left perspective view thereof, wherein a detachable brush of the reflex hammer is shown removed from an end of the telescoping handle; FIG. 10 is a top-right perspective view thereof, wherein the telescoping handle of the reflex hammer is in an extended state, and the rotatable head is disposed parallel to the telescoping handle shown at a slightly reduced scale; FIG. 11 is a bottom plan view thereof, wherein the telescoping handle of the reflex hammer is in an unextended state, and the rotatable head is disposed perpendicular to the telescoping handle; FIG. 12 is a right side elevational view thereof, wherein the telescoping handle of the reflex hammer is in an unextended state, and the rotatable head is disposed perpendicular to the telescoping handle; an elevational view of the left side being a mirror image thereof; FIG. 13 is a bottom plan view thereof, wherein the telescoping handle of the reflex hammer is in an extended state, and the rotatable head is disposed perpendicular to the telescoping handle shown at a slightly reduced scale; FIG. 14 is a partial bottom plan view thereof, wherein the rotatable head is disposed perpendicular to the telescoping handle; and the head locking collar in a locked position shown at an enlarged scale; and, FIG. 15 is a partial right side elevational view thereof, wherein the rotatable head is disposed parallel to the telescoping handle; and the head locking collar is in a pulled-back position, an elevational view of the left side being a mirror image thereof shown at an enlarged scale.

1 Claim, 15 Drawing Sheets

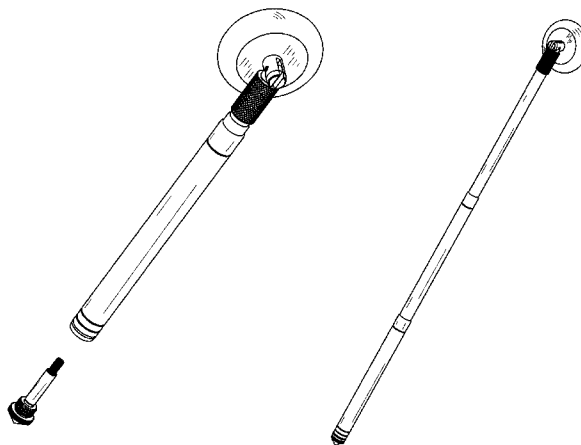

(56)

References Cited

U.S. PATENT DOCUMENTS

2,054,849	A *	9/1936	Briggs	601/107
2,532,093	A *	11/1950	Field et al.	600/553
2,858,898	A *	11/1958	Cinquini	181/137
D252,283	S *	7/1979	Reeves-Saunders	D24/142
4,324,261	A *	4/1982	Mark et al.	600/553
5,909,495	A *	6/1999	Andrea	181/131
6,406,436	B1 *	6/2002	Schiffman	600/557
D535,025	S	1/2007	Bhavnani	
D583,942	S	12/2008	Mandel	
D682,424	S *	5/2013	Hasbun	D24/142

OTHER PUBLICATIONS

MDF Instruments Product Brochure, dated earlier than Apr. 2012 (exact date unknown).

Printout of product packaging for MDF 535 Babinski Reflex Hammer, dated Sep. 13, 2011 or before.

Printout of webpage from www.adctoday.com depicting a ADC Telescoping Babinski Hammer, dated May 28, 2013 or before.

Printout of webpage from www.amazon.com depicting various types of Babinski Reflex Hammers, dated May 28, 2013 or before.

Printout of webpage from www.mdfinstruments.com depicting a MDF 535 Babinski Reflex Hammer, dated May 28, 2013 or before.

Printout of webpage from www.medisave.net depicting a Babinski Telescoping Reflex Hammer, dated May 28, 2013 or before.

Printout of webpage from www.studentmedicalshop.com depicting a Reflex Hammer—Telescoping Babinski, dated May 28, 2013 or before.

* cited by examiner

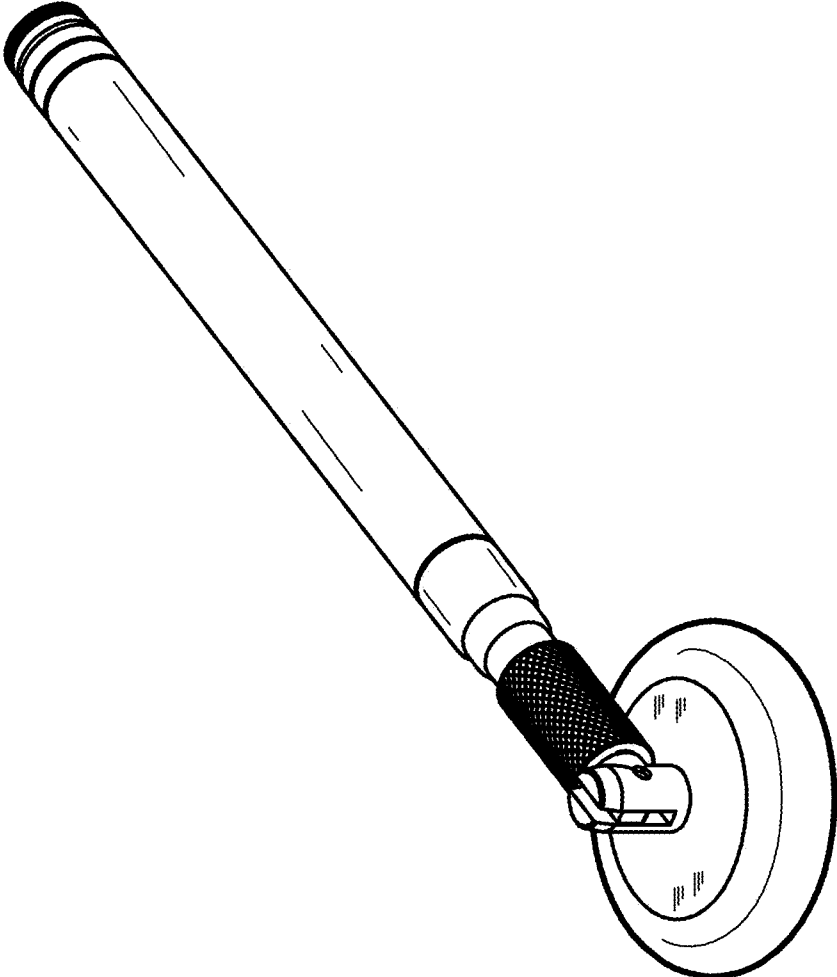

FIG. 1

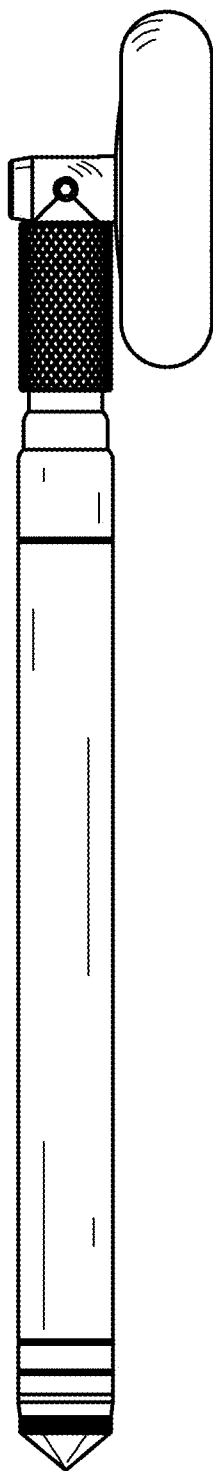

FIG. 2

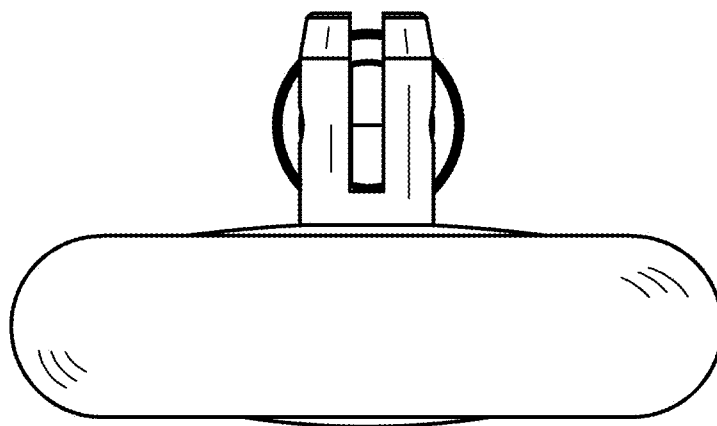

FIG. 3

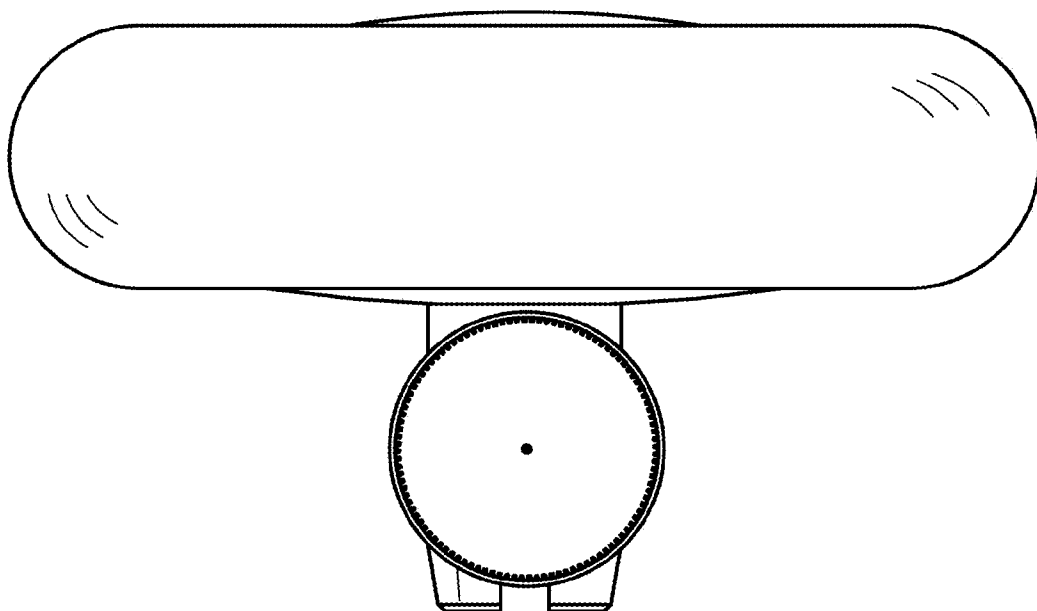

FIG. 4

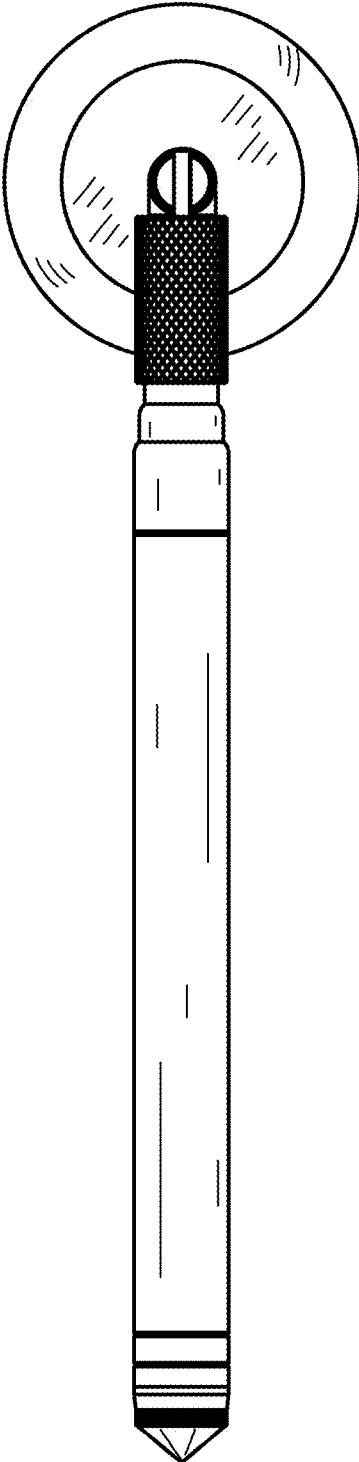

FIG. 5

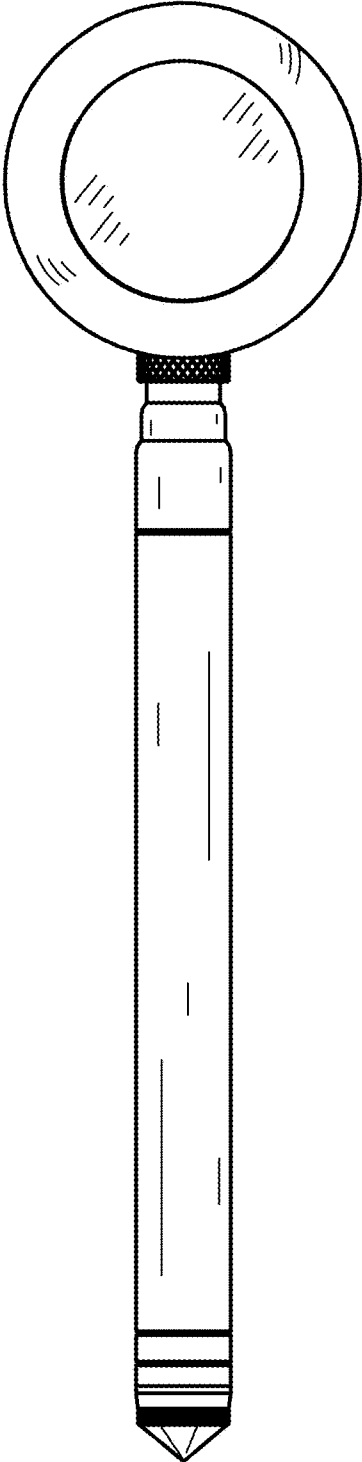

FIG. 6

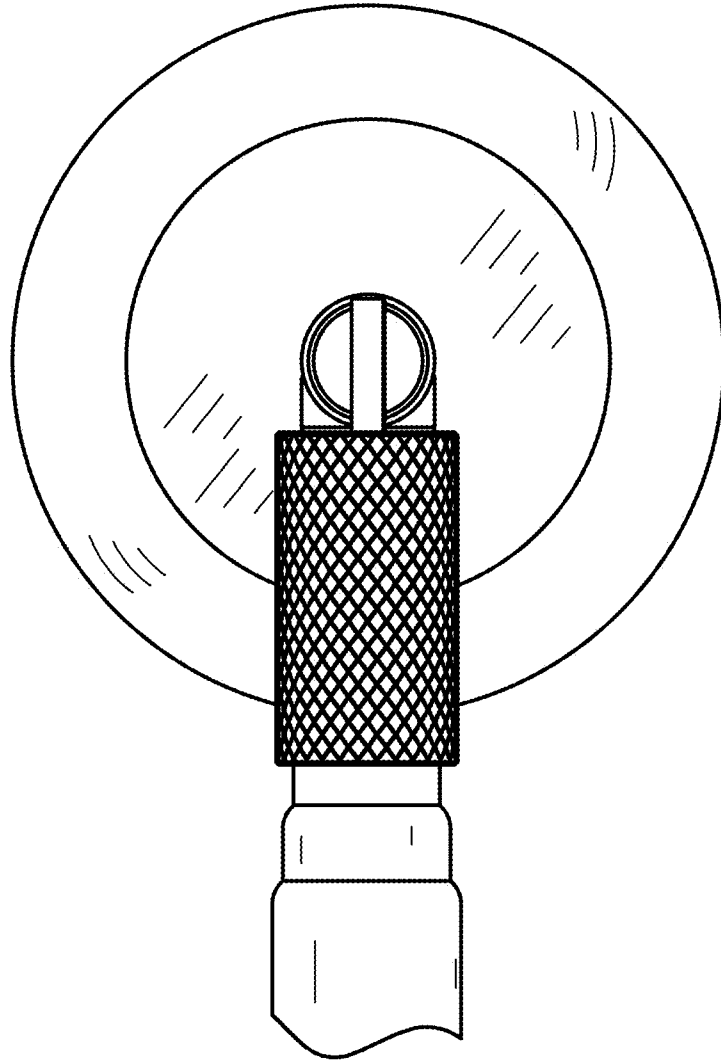

FIG. 7

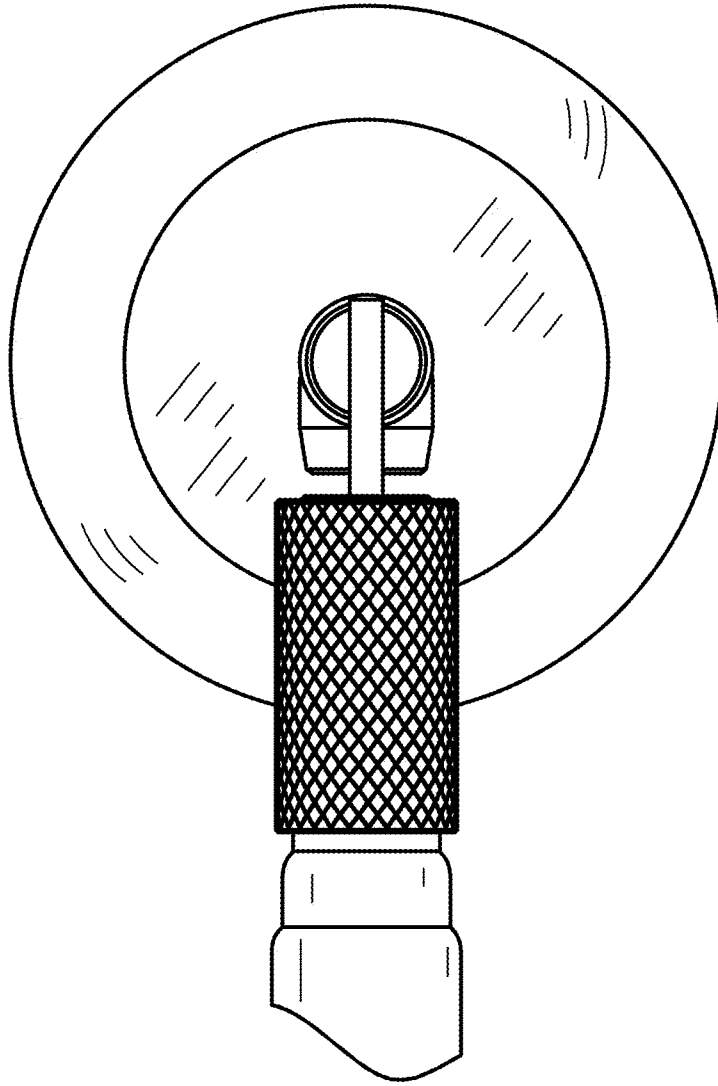
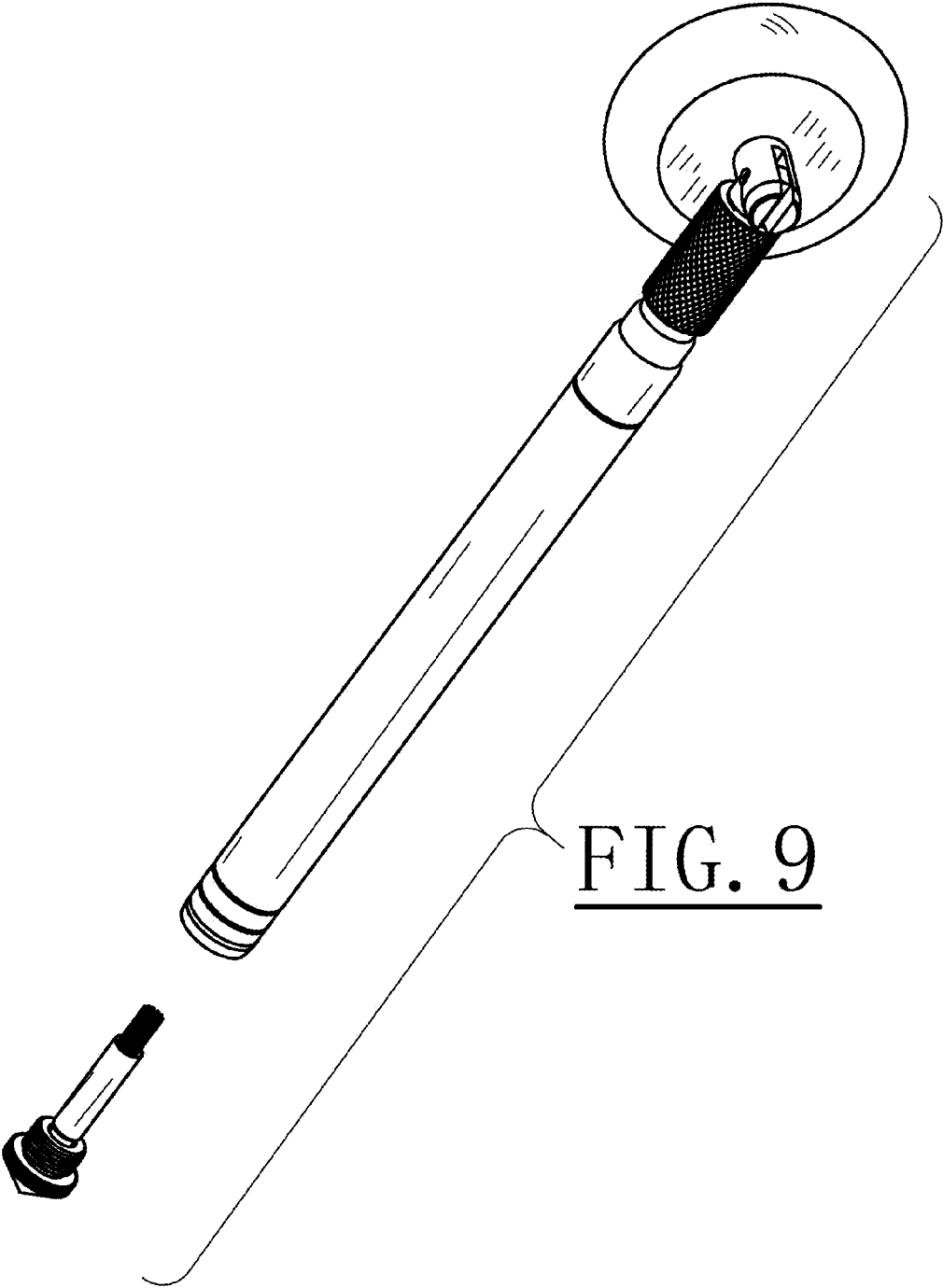

FIG. 8



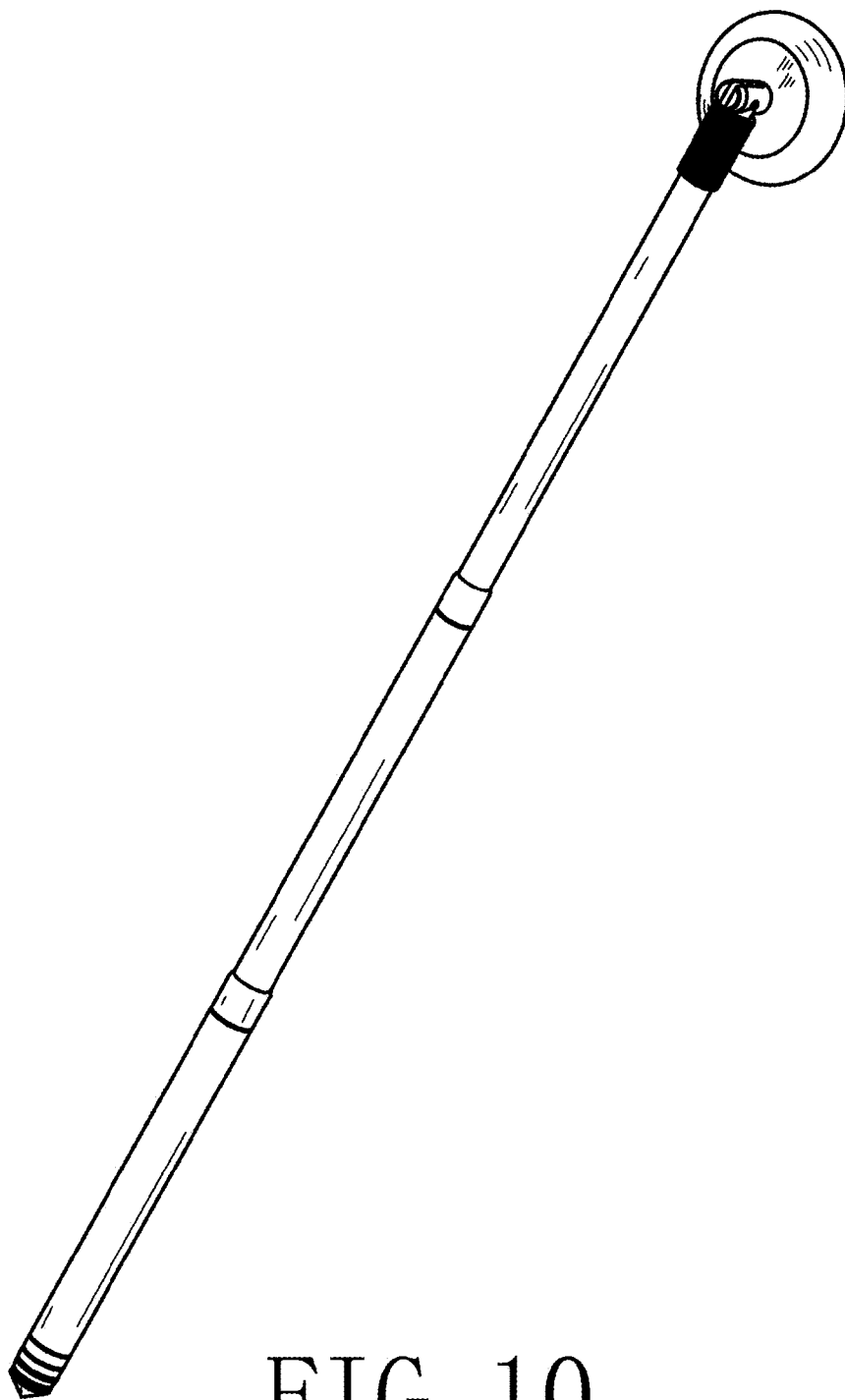

FIG. 10

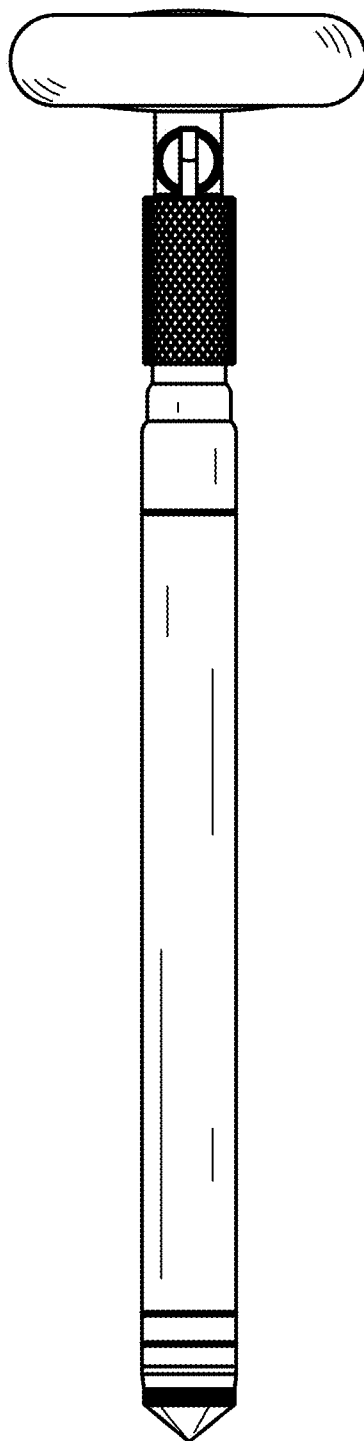

FIG. 11

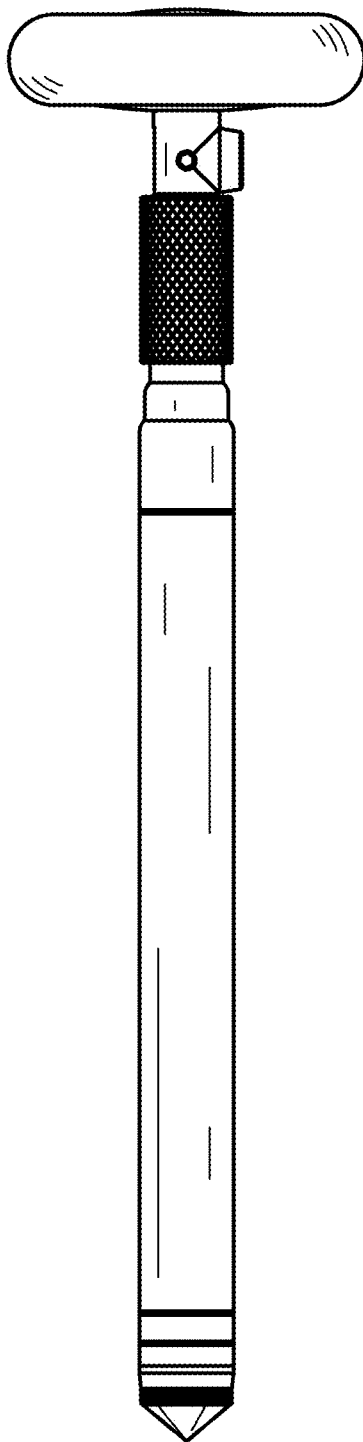

FIG. 12

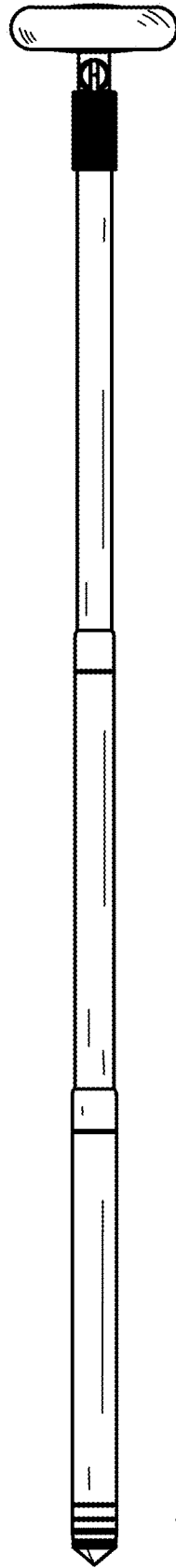

FIG. 13

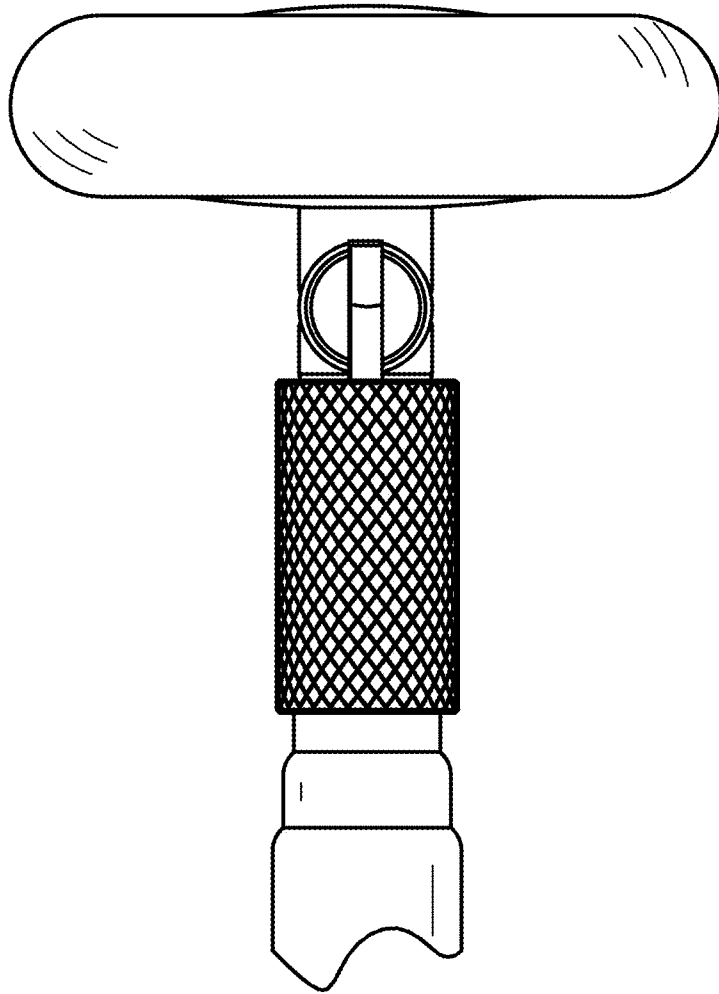

FIG. 14

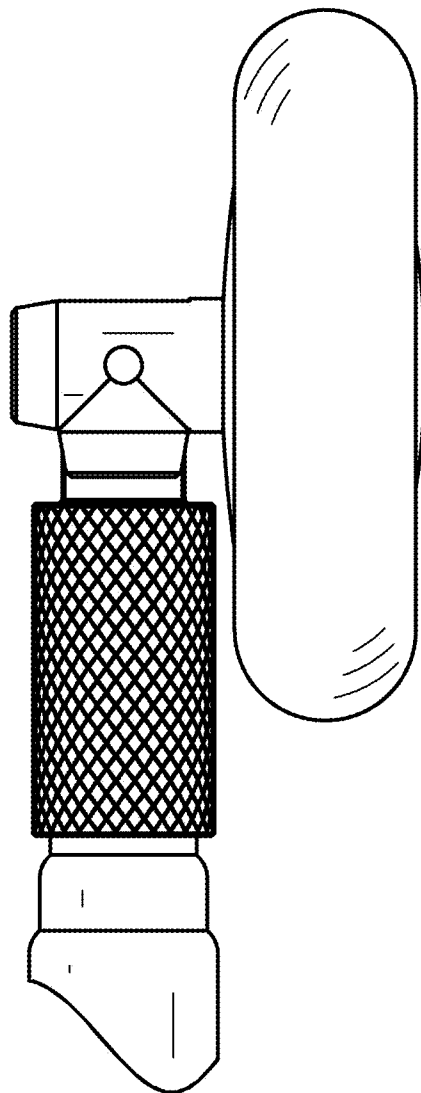

FIG. 15