

April 14, 1964

H. LIENER-KUNDE

3,129,042

DRAWER GUIDE

Filed Feb. 23, 1962

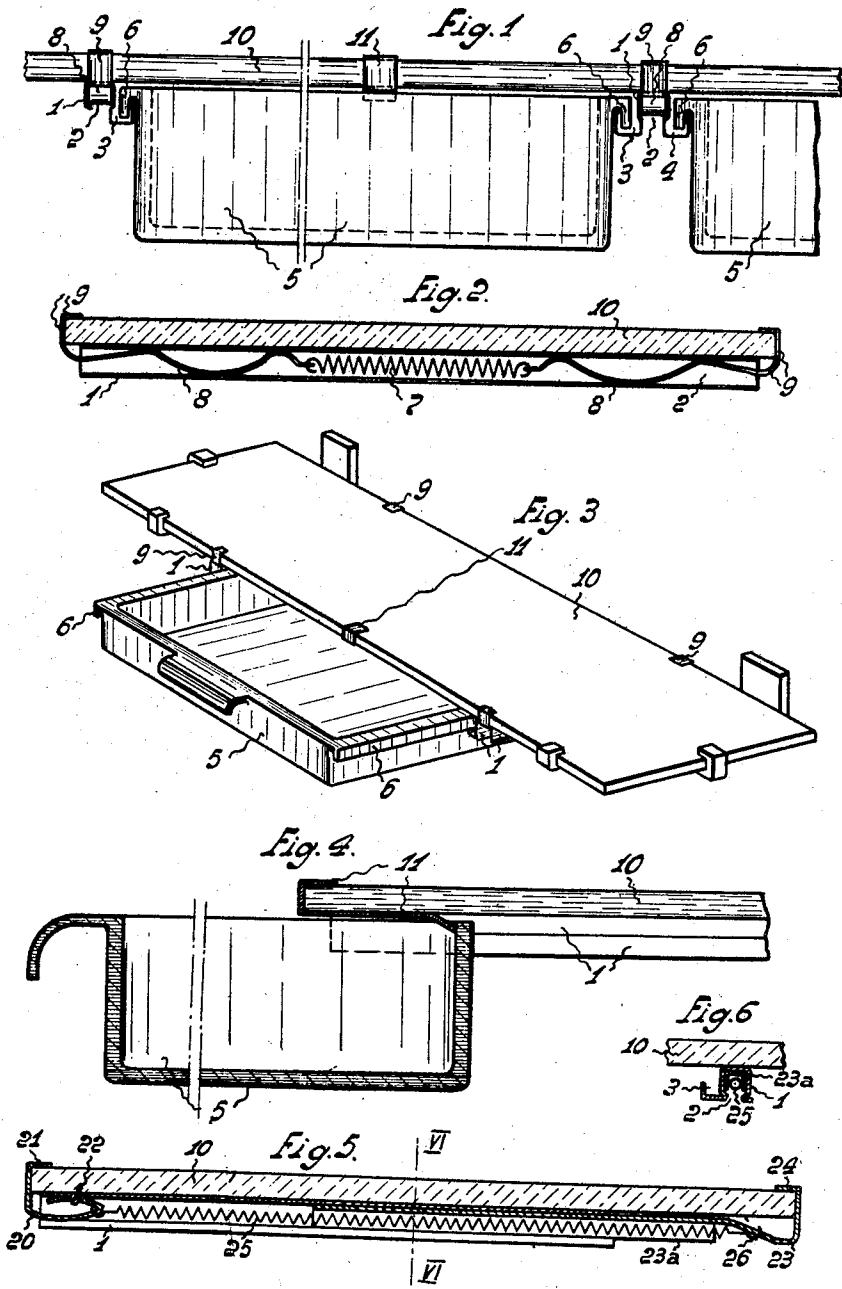

1

3,129,042

**DRAWER GUIDE**

Henriette Liener-Kunde, Hofstrasse 79,  
Zurich 7, Switzerland

Filed Feb. 23, 1962, Ser. No. 175,215

Claims priority, application Switzerland Feb. 24, 1961  
6 Claims. (Cl. 312-246)

The invention relates to a drawer guide for drawers to be mounted on the underside of a shelf, with guide bars provided on the drawer for engaging with guide bars on the drawer guide.

The drawer guide according to the invention has a profile rail with holding members guiding in it at both ends and having hook-shaped ends for attaching over opposite edges of a shelf, at least one of these holding members being movable in the profile rail against the force of a tension-spring and the holding members being formed in such a way that the free portions of the hooked ends to engage the upper side of the shelf tend to move resiliently toward the upper side of the profile rail.

The holding members may, for instance, be connected to each other by one common tension-spring, or a special spring attached to the profile rail can be provided for each holding member. Also, only one holding member may be movable in the profile rail, whilst the other is held fixed in the profile rail.

In order that the drawer guide may be used with shelves of different widths, it is of advantage for the movable holding member, guided in the rear end of the profile rail, to be extended forwardly beyond the point of attachment of the tension-spring, in order to guide this holding member when partly drawn out of the profile rail and nevertheless to make it possible to give the tension spring a sufficient length.

Preferably the profile rail has a part of C-shaped cross-section for taking and guiding the holding members, and on one or both sides of this part, a channel of U-shaped cross-section intended for receiving guide bars arranged on the drawer.

Two embodiments of the drawer guide according to the invention are represented by way of example in the accompanying drawing, in which:

FIG. 1 is a front view of a drawer guide arranged on a shelf in position of use and with a drawer pushed in,

FIG. 2 a longitudinal section through the drawer guide, fitted on a shelf represented in cross-section,

FIG. 3 a view of a laboratory glass shelf with drawer guides arranged thereon and a drawer pulled half way out,

FIG. 4 a cross-section through the shelf according to FIG. 3, with drawer guide and drawer,

FIG. 5 a longitudinal section corresponding to FIG. 2 of another embodiment of the drawer guide, and

FIG. 6 a cross-section on the line VI-VI in FIG. 5.

The illustrated drawer guides have a profile rail 1 of drawn metal, or bent-over sheet metal, or molded plastics.

The profile rail 1 has a channel 2 of C-shaped cross-section and on one or both sides of it a channel 3 and/or of U-shaped cross-section. Two channels 3 and 4 are provided on drawer guides for two drawers arranged alongside each other, as shown in FIG. 1. The free edge of the channel 3 and/or 4 serves as guide for guide bars 6 provided at the sides of a drawer 5.

According to FIG. 2, two holding members 8 with hook-like ends 9 are movably guided in the channel 2 against the force of a tension-spring 7. The hook-like ends 9 are intended for attaching over opposite edges of a shelf 10.

The holding member 8, bent from spring strip, has such shape that the spring strip rests at one place on flanges

2

provided at the lower edges of the channel 2 and at another place on the upper wall of the channel, so that the hook-shaped end 9 rests with the free hook part resiliently on the upper side of the shelf 10, whereby the guide is pressed against the under side of the shelf.

Instead of one common tension-spring 7, a special spring may be provided for each of the members 8, one end of each spring being fixed to the profile rail 1.

As stop to prevent the drawer from being completely pulled out of the guides, a U-shaped spring clip 11 is provided, which can be pushed over the front edge of the shelf 10.

The drawer 5 may, for instance, be made of pressed or molded plastics, or of metal or wood.

FIGS. 5 and 6 show a drawer guide which can be mounted on shelves of different widths.

Here too, a profile rail 1 with C-shaped channel 2 and U-shaped channel 3 is provided. In the front end of the profile rail 1, a holding member with a hook-shaped end 21 is guided. In order that the profile rail 1 always remains near the front edge of the shelf, when shelves of different widths are used, the holding member 20 is held fixed in the profile rail 1. For this purpose a cam 22 is formed on the inside of the rail 1, which cooperates with a bore in the holding member 20.

A holding member 23 with a hook-shaped end 24 is guided in the rear end of the profile rail 1. The holding member 23 is movable in the profile rail 1 against the force of a draw-spring 25, which engages with the holding member 23 at 26 and the other end of which is fixed to the front holding member 20. It will be clear that the front end of spring 25 could also be fixed to the profile rail 1 or to another part connected to this rail.

For guiding the rear holding member 23 in the profile rail 1, an extension 23a of U-shaped cross-section is provided on the holding member 23. This extension is slidable in the C-shaped channel 2 and extends forwardly beyond the point 26 where the spring is attached to the holding member.

One will recognize that the rear holding member 23 can be drawn far out of the profile rail 1 without the extension 23a losing its guiding engagement in the profile rail. In spite of that, the spring 25 is sufficiently long to allow such pulling-out without any undue increase in the force of the spring. It will be apparent therefore, that the drawer guide according to FIGS. 5 and 6 is suitable for using on shelves of different widths. In order to further reduce the increase in the force of the spring when mounting the guide on a relatively wide shelf, the front end of spring 25 may also be fixed to a special holding part, which is guided in the profile rail like the front holding member 20 and which can be held fixed in the rail at different places, for instance by a cam collaborating with holes in the profile rail.

Since the extension 23a of the rear holding member 23 is U-shaped in cross-section, this extension is particularly well guided in the C-shaped channel 2 of the profile rail. At the same time space is available within the extension 23a for the spring 25, which runs approximately in the longitudinal axis of the extension.

What I claim is:

1. A drawer guide for drawers to be mounted on the underside of a shelf, with guide bars provided on the drawer for engaging with the drawer guide, said drawer guide consisting of a profile rail, holding members guided in both ends of said rail with hook-shaped ends for attaching over opposite edges of a shelf, at least one of said holding members being movable in said profile rail against the force of a tension-spring and the holding members being formed in such a way that the free portions of the hooked ends to engage the upper side of the shelf tend to move resiliently toward the upper side of the profile rail.

3

2. A drawer guide as claimed in claim 1, said profile rail having a channel of C-shaped cross-section for taking and guiding the holding members, and on one or both sides of said C-shaped channel, a channel of U-shaped cross-section, for receiving guide bars arranged on the drawer.

3. A drawer guide as claimed in claim 2, each of said holding members consisting of a strip spring with a hook-shaped end and having within the channel of C-shaped cross-section of the profile rail, such a bend that the free, hook-shaped end is resiliently pressed toward the upper side of the guide by the engagement of parts of the strip spring with lower and upper portions of the C-shaped channel.

4. A drawer guide as claimed in claim 1, in which the holding member guided in the front end of the profile rail is firmly held in the profile rail, whilst the holding member guided in the rear end of the profile rail is movable against the force of a tension-spring which is attached at

4

one end to said rear holding member and at the other end to the profile rail.

5. A drawer guide as claimed in claim 1, in which the movable member guided in the rear end of the profile rail projects forwardly beyond the point of attachment of the tension-spring, in order to guide said holding member when moved out of the profile rail.

6. A drawer guide as claimed in claim 5, in which the part of the rear holding member projecting beyond the point of attachment of the spring has an extension U-shaped in cross-section, and in which the tension-spring is arranged within said U-profile.

#### References Cited in the file of this patent

#### UNITED STATES PATENTS

735,716	Dahlquist	Aug. 11, 1903
1,774,313	Braeutigam	Aug. 26, 1930
2,673,601	Fischer et al.	Mar. 30, 1954