



J. SOSS.  
 MACHINE FOR MOLDING BUILDING BLOCKS.  
 APPLICATION FILED NOV. 1, 1907.

903,908.

Patented Nov. 17, 1908.

2 SHEETS—SHEET 2.

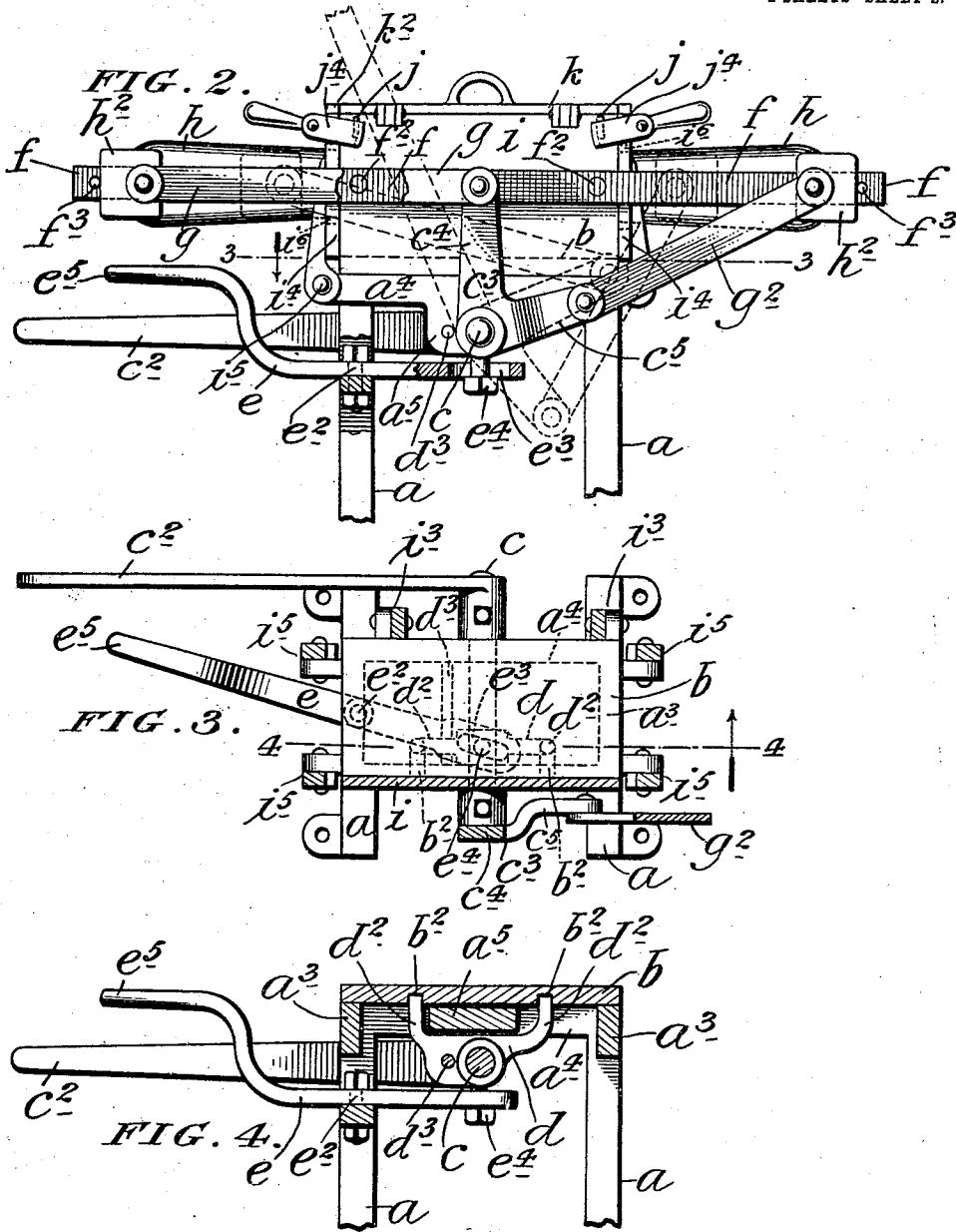

WITNESSES,  
*C. E. Mulhearny*  
*M. E. Doody*

INVENTOR,  
*Joseph Soss,*  
 BY *Edgar Tate & Co.*  
 ATTORNEYS..

# UNITED STATES PATENT OFFICE,

JOSEPH SOSS, OF NEW YORK, N. Y.

## MACHINE FOR MOLDING BUILDING-BLOCKS.

No. 903,908.

Specification of Letters Patent.

Patented Nov. 17, 1908.

Application filed November 1, 1907. Serial No. 400,155.

*To all whom it may concern:*

Be it known that I, JOSEPH SOSS, a citizen of the United States, and residing at New York, in the county of New York and State of New York, have invented certain new and useful Improvements in Machines for Molding Building-Blocks, of which the following is a specification, such as will enable those skilled in the art to which it appertains to make and use the same.

This invention relates to the manufacture of building blocks composed of concrete or similar material, and the object thereof is to provide an improved machine for molding building blocks of this class; a further object being to provide a machine of this class designed particularly for molding my improved inter-locking building bricks or blocks, and with these and other objects in view my invention consists in a machine of the class specified constructed as hereinafter described and claimed.

The invention is fully disclosed in the following specification of which the accompanying drawing forms a part, in which the separate parts of my improvement are designated by suitable reference characters in each of the views, and in which;—

Figure 1 is a perspective view of my improved machine showing the same open and showing also a building block resting on the bed plate of the machine. Fig. 2 a back view of the machine showing the same closed and showing part of the construction broken away. Fig. 3 a sectional plan view on the line 3, 3 of Fig. 2, and;—Fig. 4 a partial sectional view on the line 4, 4 of Fig. 3.

In the practice of my invention as shown in the drawing I provide a main frame comprising upright end members  $a$  connected by a rectangular open work top portion, the form of which is indicated by dotted lines in Fig. 3, and the top portion of the frame is composed of transverse end portions  $a^3$ , and front and back portions  $a^4$ , and the front and back portions  $a^4$  are connected by a plate  $a^5$ .

Mounted on the top of the main frame is a plate  $b$ , which constitutes the bed plate of the mold proper, and mounted horizontally beneath the plate  $a^5$  of the frame and parallel therewith and ranging forwardly and backwardly of the machine is a shaft  $c$ , to the front end of which is secured an arm  $c^2$ , and to the rear end of which is secured a

crank lever  $c^3$ . The front and back top plates  $a^4$  of the main frame are provided with hangers  $a^6$  in which the shaft  $c$  has bearings, and mounted on said shaft is a yoke  $d$ , the arms  $d^2$  of which extend upwardly and are movable in grooves  $b^2$  formed in the bottom of the plate  $b$ , and which open backwardly through the rear edge of said plate, and mounted parallel with the shaft  $c$  is a rod  $d^3$  which passes through the cross head portion of the yoke  $d$  and serves to hold said yoke in proper position in the operation of the machine as hereinafter described.

A lever  $e$  is pivoted at  $e^2$  to the right hand side of the main frame and this lever is provided with a longitudinal slot  $e^3$  through which passes a headed pin  $e^4$  connected with the yoke  $d$ , and the outer end of said lever is curved upwardly and formed into a handle  $e^5$  which ranges in the same general direction as the arm  $c^2$  and by means of this lever the bed plate  $b$  may be moved forwardly when the machine mold is open as shown in Fig. 1, and the grooves  $b^2$  permit the removal of the plate  $b$  when desired.

Mounted at the back of the machine is a bar  $f$ , which is rigidly secured to the back portion of the mold proper as shown at  $f^2$ , and which ranges longitudinally of the machine and projects beyond the opposite ends thereof, and connected with one arm  $c^4$  of the crank lever  $c^3$  is a link  $g$  and connected with the other arm  $c^5$  of said crank lever is another link  $g^2$ . At the opposite ends of the mold portion of the machine and forming part of said mold are cores  $h$  provided at their outer ends with backwardly directed lugs  $h^2$ , to which the links  $g$  and  $g^2$  are pivoted and the bar  $f$  passes loosely through the lugs  $h^2$  and the cores  $h$  are freely movable on said bar, and said cores are also preferably tapered from their outer to their inner ends and are cylindrical in cross section, and the outer movement of the cores  $h$  is limited by pins or stops  $f^3$  in the ends of the bar  $f$ .

The mold proper of which the plate  $b$  forms the bottom is composed of said plate, a stationary back jaw member  $i$  connected with the top portion of the main frame, a front jaw member  $i^2$  hinged to the front of the top portion of the main frame as shown at  $i^3$ , and end jaw members  $i^4$  hinged to the top end portions of the main frame at  $i^5$ , and the hinged end jaw members are pro-

vided with central circular apertures  $i^5$  through which the cores  $h$  pass.

The stationary back jaw member  $i$  of the mold is provided adjacent to the top back  
5 corners thereof with segmental lugs  $j$ , and the end jaw members  $i^4$  of the mold are provided with outwardly directed ears  $j^2$  in  
10 which are mounted shafts  $j^3$  provided at their rear ends with locking arms  $j^4$  which are adapted to engage the lugs  $j$ , and said shafts are provided at their front ends with locking arms  $j^5$  which are adapted to engage lugs  $j^6$  on the front hinged jaw  $i^2$  of the  
15 mold, and the locking arms  $j^5$  are provided with handles  $j^7$  by which they, the shafts  $j^3$  and the arms  $j^4$  may be operated.

The locking arms  $j^5$  are provided with inwardly directed flanges  $j^8$  at their ends which engage the lugs  $j^6$ , and the arms  $j^4$   
20 are provided with similar flanges which engage the lugs  $j$ .

The front hinged jaw member  $i^2$  of the mold is provided on its inner face with elevations  $m$  and corresponding depressions  $m^2$ ,  
25 said elevations and depressions being arranged in transverse longitudinal and diagonal rows and the central elevation  $m$  is pyramidal and truncated in form, while the side elevations are semi-pyramidal and truncated in form. The central depressions  $m^2$   
30 are pyramidal and truncated in form, while the side depressions are semi-pyramidal and truncated in form, and the corner depressions represent one quarter of a pyramidal and truncated depression.

The stationary back jaw member  $i$  is provided with elevations and depressions  $m$  and  $m^2$ , which are the counterparts of the elevations and depressions in the hinged jaw  
40 member  $i^2$ , or in other words the elevations  $m$  on the stationary back jaw member  $i$  correspond with the depressions in the hinged jaw member  $i^2$  while the depressions in the hinged jaw member  $i$  correspond with the  
45 elevations on the jaw member  $i^2$ . I have also shown at  $l$  in Fig. 1 a building brick or block mounted on the bed plate  $b$  of the mold, and the opposite sides or bedding surface of said brick or block are provided  
50 with elevations and depressions corresponding with the elevations and depressions on the inner surfaces of the parts  $i$  and  $i^2$  of the mold, and building bricks or blocks made in this manner may be inter-locked in any desired  
55 position as long as said building bricks or blocks are placed longitudinally or transversely of each other.

The top plate or cover  $k$  of the mold which is hinged to the stationary back jaw  
60 member  $i$  is of the same form and dimensions as the top plane surface of the brick or block  $l$ , another plane surface being formed by the base plate  $b$ , and said cover  $k$  is provided at its opposite ends with lugs or  
65 projections  $k^2$ , and at its front or free edge

with a similar lug or projection  $k^3$  and when the hinged front jaw  $i^2$  and the end jaw member  $i^4$  of the mold are closed, and the top plate or cover  $k$  also closed, the lugs or projections  $k^2$  will rest on the hinged end  
70 members or jaws  $i^4$  while the lug or projection  $k^3$  will rest on the front jaw member  $i^2$ .

The front jaw member  $i^2$  is also provided with lugs or projections  $o^2$  which bear on the end jaw members  $i^4$  when the parts of the  
75 mold are closed and said jaw member  $i^2$  is also provided centrally with an outwardly directed projection  $n$ , which forms a handle by which said jaw member may be raised into the closed position, or lowered into the open  
80 position as shown in Fig. 1.

The operation will be readily understood from the foregoing description when taken in connection with the accompanying drawing and the following statement thereof.  
85 Suppose the mold to be open as shown in Fig. 1. If it is desired to make a brick or block, the end jaw members  $i^4$  are swung into the closed position as shown in Fig. 2, the shafts  $j^3$  forming handles for this purpose. The  
90 front jaw member  $i^2$  is then raised into the closed position and the said parts are locked together or to the back jaw member  $i$  by means of the locking arms  $j^5$  the locking arms  $j^4$  and the shafts  $j^3$ , the arms  $j^5$  and  $j^4$  engaging the lugs or projections  $j^6$  on the front  
95 jaw member  $i^2$ , while the arms  $j^4$  engage the lugs  $j$  on the stationary jaw member  $i$ . The arm  $c^2$  is then operated so as to swing the crank lever  $c^3$  into the position shown in  
100 dotted lines in Fig. 2, in which operation the links  $g$  and  $g^2$  are also thrown into the position shown in dotted lines in said figure, and the corresponding cores  $h$  are forced inwardly into the middle portion of the mold.  
105 The inner ends of these cores when in their innermost position abut, and when the parts of the mold have been forced into the position above described the mold is filled with the concrete or other material from which  
110 the brick or block is to be made, after which the top plate or cover  $k$  is closed down on the concrete or other material. The top plate or cover  $k$  is not essential in molding the brick or block and is used principally for stamping  
115 or molding in the surface of the brick or block any design, advertisement or other information that may be desired and the surface of the concrete or other material in the mold may be smoothed off with a straight  
120 edge or other device before lowering the top plate or cover  $k$  if preferred. After the brick or block has been formed in the manner described the operation of closing the parts of the mold is reversed, the front jaw  $i^2$  is  
125 thrown open as shown in Fig. 1, the arm  $c^2$  is operated to throw the links  $g$  and  $g^2$  into the position shown in full lines in Fig. 2; the cores  $h$  are forced outwardly as shown in said figure and the lever  $e$  is operated to move the  
130

base plate *b* of the mold forwardly as shown in Fig. 1, after which the said plate *b* with the brick or block thereon is removed. In practice, a large number of the plates *b* are provided and in removing the bricks or blocks from the machine they are retained on their respective base plates and are allowed to become hard and the material thereof to be fully set before they are removed from said plates.

The object of the cores *h* is to form central longitudinal bores or openings *o*<sup>3</sup> in the bricks or blocks *l*, and while my improved building brick or block molding machine is designed particularly for the manufacture of my improved inter-locking building bricks or blocks, the same may be employed for making other styles of building bricks or blocks, in which event the inner face of the jaw *i* and *i*<sup>2</sup> may be smooth or of any other form, and either the base plate *b* of the mold or the top plate or cover *k* may be provided with means for marking the building brick or block formed in the mold if desired.

Having fully described my invention, what I claim as new and desire to secure by Letters Patent, is:—

1. In a brick molding machine, a main frame, and a mold comprising a base plate placed on the main frame and movable forwardly and backwardly, a back jaw, a hinged front jaw, oppositely arranged hinged end jaws, cores movable longitudinally through said end jaws, and means for operating said cores, means for locking the end and front jaws in a closed position, the adjacent faces of the front and back jaws being provided with elevations and depressions arranged in transverse longitudinal and diagonal rows, the elevations and depressions with which one of said jaws is provided being the coun-

ter-part of those with which the other jaw is provided.

2. In a block molding machine, a main frame and a mold composed of a base plate movable forwardly and backwardly on the top of the frame, means for operating said plate, a back jaw, a front jaw hinged to the main frame, oppositely arranged end jaws hinged to the main frame, a bar secured to the back jaw, cores slidably mounted on said bar and movable through the end jaws, means for operating said cores, and means for locking the front jaw and the end jaws in a closed position.

3. In a block molding machine, a main frame and a mold composed of a base plate movable forwardly and backwardly on the top of the frame, means for operating said plate, a back jaw, a front jaw hinged to the main frame, oppositely arranged end jaws hinged to the main frame, a bar secured to the back jaw, cores slidably mounted on said bar and movable through the end jaws, means for operating said cores, and means for locking the front jaw and the end jaws in a closed position, the inner surfaces of the front and back jaws being provided with elevations and depressions arranged in transverse longitudinal and diagonal rows, the elevations and depressions with which one of said jaws is provided being the counter-parts of those with which the other jaw is provided substantially as shown and described.

In testimony that I claim the foregoing as my invention I have signed my name in presence of the subscribing witnesses this 30th day of October, 1907.

JOSEPH SOSS.

Witnesses:

C. E. MULREANY,  
M. E. DOODY.