

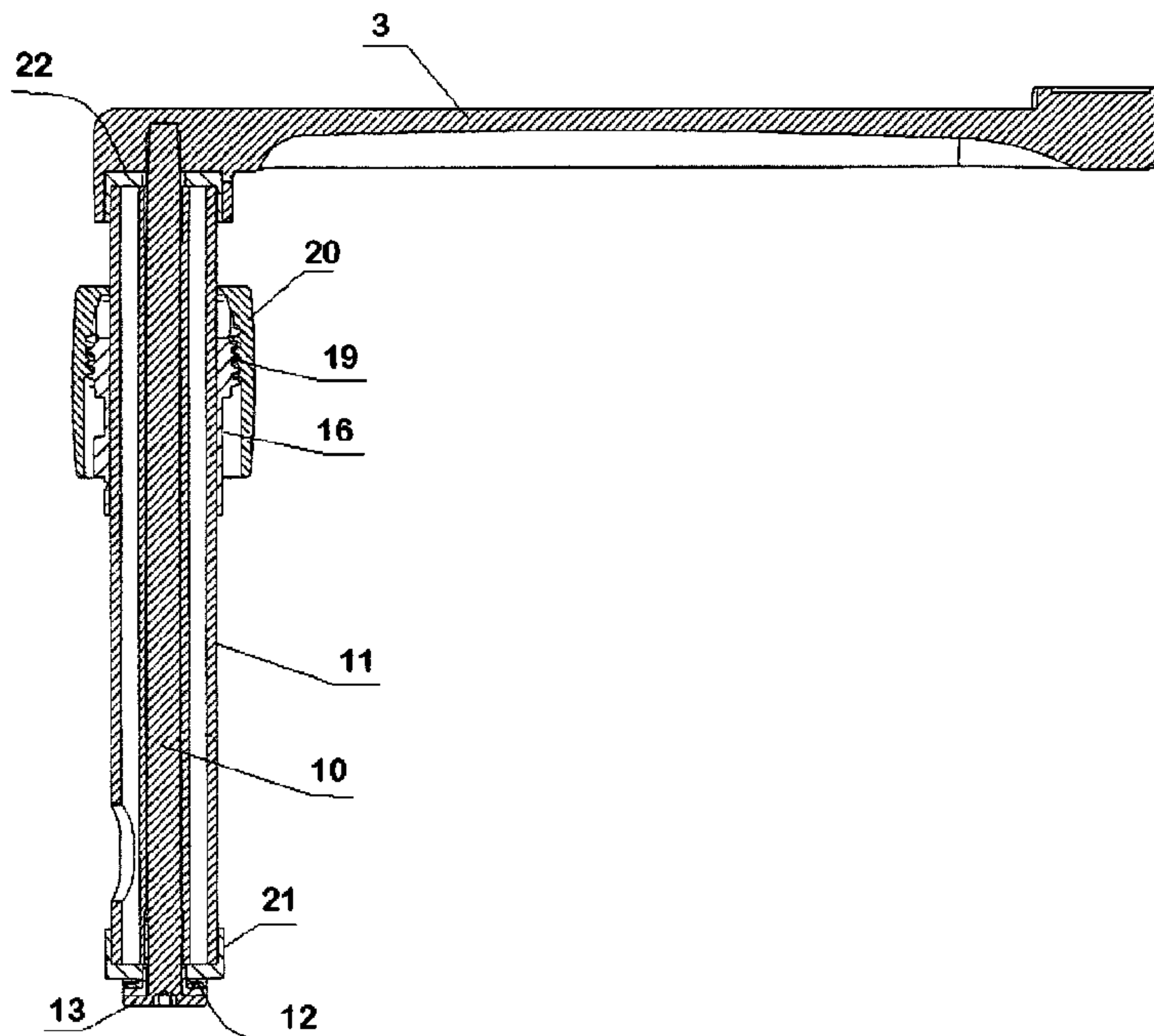

(86) **Date de dépôt PCT/PCT Filing Date:** 2010/10/19
 (87) **Date publication PCT/PCT Publication Date:** 2011/04/28
 (45) **Date de délivrance/Issue Date:** 2016/10/11
 (85) **Entrée phase nationale/National Entry:** 2012/03/21
 (86) **N° demande PCT/PCT Application No.:** NO 2010/000366
 (87) **N° publication PCT/PCT Publication No.:** 2011/049458
 (30) **Priorité/Priority:** 2009/10/19 (NO20093169)

(51) **Cl.Int./Int.Cl. A47B 17/03** (2006.01),
A47B 21/03 (2006.01), **A47B 23/02** (2006.01),
A47B 83/02 (2006.01), **A47B 96/18** (2006.01),
A47C 7/70 (2006.01)
 (72) **Inventeur/Inventor:**
 JARNES, WEBJOERN, NO
 (73) **Propriétaire/Owner:**
 EKORNES ASA, NO
 (74) **Agent:** DENNISON ASSOCIATES

(54) **Titre : BRAS TELESCOPIQUE POUR TABLETTE DE SUPPORT D'ORDINATEUR PERSONNEL**
 (54) **Title: TELESCOPIC ARM FOR A PC TABLE**



(57) **Abrégé/Abstract:**

Rotating telescopic column that includes an outer sleeve (7) with a number of interior cams, a telescopic sleeve (11) located inside the outer sleeve (7) and that has a corresponding number of outer slots (15), as the cams in the outer sleeve (7) is designed to intervene in the slots (15) in the telescopic sleeve (11) and thereby prevents the telescopic sleeve from turning relative to the outer sleeve, a locking clamping mechanism attached to the outer sleeve (7), and grip the telescopic sleeve (11), and is designed to lock the telescopic sleeve to the outer sleeve when the telescopic sleeve is in a selected position relative to the outer sleeve, an axle (10) located inside the telescopic sleeve (11) and is rotatable in relation to this.

(12) INTERNATIONAL APPLICATION PUBLISHED UNDER THE PATENT COOPERATION TREATY (PCT)

(19) World Intellectual Property Organization
International Bureau(43) International Publication Date
28 April 2011 (28.04.2011)(10) International Publication Number
WO 2011/049458 A1

(51) International Patent Classification:

A47B 17/03 (2006.01) A47B 21/03 (2006.01)
A47B 83/02 (2006.01) A47B 23/02 (2006.01)
A47B 96/18 (2006.01) A47C 7/70 (2006.01)

(21) International Application Number:

PCT/NO2010/000366

(22) International Filing Date:

19 October 2010 (19.10.2010)

(25) Filing Language:

English

(26) Publication Language:

English

(30) Priority Data:

20093169 19 October 2009 (19.10.2009) NO

(71) Applicant (for all designated States except US): **EKO-RNES ASA** [NO/NO]; N-6222 Ikornnes (NO).

(72) Inventor; and

(75) Inventor/Applicant (for US only): **JARNES, Webjørn** [NO/NO]; Sørestrandveien 790, N-6222 Ikornnes (NO).(74) Agent: **OSLO PATENTKONTOR AS**; Postboks 7007 M, N-0306 Oslo (NO).

(81) Designated States (unless otherwise indicated, for every kind of national protection available): AE, AG, AL, AM, AO, AT, AU, AZ, BA, BB, BG, BH, BR, BW, BY, BZ, CA, CH, CL, CN, CO, CR, CU, CZ, DE, DK, DM, DO, DZ, EC, EE, EG, ES, FI, GB, GD, GE, GH, GM, GT, HN, HR, HU, ID, IL, IN, IS, JP, KE, KG, KM, KN, KP, KR, KZ, LA, LC, LK, LR, LS, LT, LU, LY, MA, MD, ME, MG, MK, MN, MW, MX, MY, MZ, NA, NG, NI, NO, NZ, OM, PE, PG, PH, PL, PT, RO, RS, RU, SC, SD, SE, SG, SK, SL, SM, ST, SV, SY, TH, TJ, TM, TN, TR, TT, TZ, UA, UG, US, UZ, VC, VN, ZA, ZM, ZW.

(84) Designated States (unless otherwise indicated, for every kind of regional protection available): ARIPO (BW, GH, GM, KE, LR, LS, MW, MZ, NA, SD, SL, SZ, TZ, UG, ZM, ZW), Eurasian (AM, AZ, BY, KG, KZ, MD, RU, TJ, TM), European (AL, AT, BE, BG, CH, CY, CZ, DE, DK, EE, ES, FI, FR, GB, GR, HR, HU, IE, IS, IT, LT, LU, LV, MC, MK, MT, NL, NO, PL, PT, RO, RS, SE, SI, SK, SM, TR), OAPI (BF, BJ, CF, CG, CI, CM, GA, GN, GQ, GW, ML, MR, NE, SN, TD, TG).

Published:

— with international search report (Art. 21(3))

[Continued on next page]

(54) Title: TELESCOPIC ARM FOR A PC TABLE

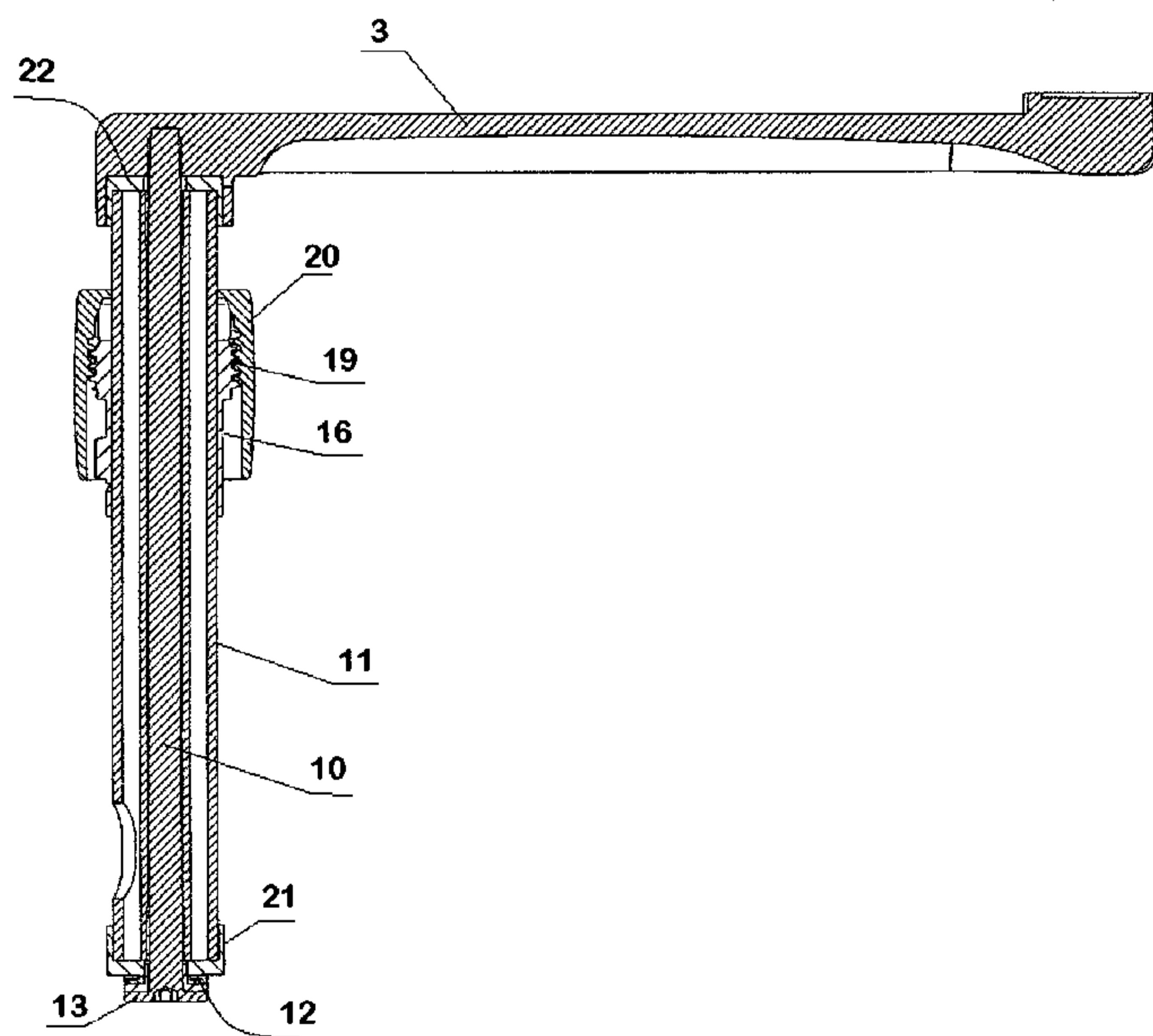

Fig. 3

(57) Abstract: Rotating telescopic column that includes an outer sleeve (7) with a number of interior cams, a telescopic sleeve (11) located inside the outer sleeve (7) and that has a corresponding number of outer slots (15), as the cams in the outer sleeve (7) is designed to intervene in the slots (15) in the telescopic sleeve (11) and thereby prevents the telescopic sleeve from turning relative to the outer sleeve, a locking clamping mechanism attached to the outer sleeve (7), and grip the telescopic sleeve (11), and is designed to lock the telescopic sleeve to the outer sleeve when the telescopic sleeve is in a selected position relative to the outer sleeve, an axle (10) located inside the telescopic sleeve (11) and is rotatable in relation to this.

WO 2011/049458 A1 

- *before the expiration of the time limit for amending the claims and to be republished in the event of receipt of amendments (Rule 48.2(h))*

Telescopic arm for a PC table

Technical field

The present invention regards a rotatable telescopic column. The column has a general application, but is particularly suitable for use in furniture, and more specifically in the PC table.

Background

The applicant markets a PC table which includes a table top that can carry a computer, more specifically a laptop computer, often called a laptop. The PC table includes an arm that carries the table top itself. The arm is attached to a column that has adjustable height and is rotatable, and which in turn is attached to a piece of furniture. The arm must be swung in and out of the workspace of the user, so that it easily can be placed in the correct working position and can be swung away when not in use. The height adjustable column includes a clamp coupling that locks the column in the desired height and with an appropriate friction so that the arm can be rotated. The prior art column has a weakness in that the friction does not remain constant during use. Wear occurs in the clamp coupling, and it is easily loosened when the joint pivots back and forth.

It is therefore a need for an improved telescopic bar that is more stable in use, where the friction can be easily adjusted, respectively, that can be locked, and where the settings are retained over time.

Summary

The present invention is intended to produce such a column. This is achieved with a telescopic column according to the present invention. The scope of the invention is shown in the following patent claims. Specifically, it is arranged a rotatable telescopic column that includes an outer sleeve, a telescopic sleeve which is located inside the outer sleeve, a locking clip mechanism attached to the outer sleeve and that grabs around the telescopic sleeve and is designed to lock the telescopic sleeve to the outer sleeve when the telescopic sleeve is in a selected position relative to the outer sleeve and a shaft located inside the telescopic sleeve and is rotatable in relation to this. It is thereby achieved that the functions for length adjustment and turning of the column are separated and do not affect each other. The column is therefore more stable in use. The clamping mechanism will not loosen during use, while the turning feature becomes very strong because of the continuous shaft.

Brief description of the drawings

An embodiment of the present invention will now be described in detail by reference to the enclosed figures, where:

5 Figure 1 is a drawing of a PC table,

Figure 2 is a perspective sketch of a telescopic column according to the invention,

Figure 3 shows a cross sectional view through the telescopic column.

Detailed description

Figure 1 shows a PC table including a table top 1. The table top is attached to a swivel
10 joint 2, which in turn is attached to an upper arm 3. The upper arm is attached to a
swivel arm or a telescopic column 4, which in turn is attached to a lower arm 5 and a
clamp attachment 6. The telescopic column 4 may be varied in length, and can rotate
around the vertical axis with appropriate friction.

The telescopic column 4 includes an outer sleeve 7 which is attached to the lower arm 5,
15 and a swivel and clamping mechanism which is located inside the outer sleeve 7. The
inner mechanism is illustrated in Figure 2, as an exploded view. The mechanism includes
a shaft 10 which is attached to the upper arm 3, for example with threads. The shaft 10
runs in a telescopic sleeve 11. The shaft is rotatable relative to the sleeve and the friction
between the shaft and the sleeve is determined by the spring washers 12, which located
20 between the screw head 13 on the shaft 10 and the end of the sleeve.

The telescopic sleeve 11 is in the form of a dual walled profile with an outer and an inner
tube connected in the same hub and a number of longitudinal bridges. Furthermore the
telescopic sleeve 11 is equipped with a number of longitudinal slots 15 that are designed
to intervene in the corresponding cams inside the outer sleeve 7. The sleeves cannot
25 thereby turn relative to each other. This means that all the turning movement occurs
between the shaft 10 and the telescopic sleeve 11, while the longitudinal telescopic
movement occurs between the outer sleeve 7 and the telescopic sleeve 11.

The telescoping column also includes a locking sleeve 16 which is arranged to be fas-
tened in the outer sleeve 7. The locking sleeve can, for this purpose, include a knob de-
30 signed to intervene in a recess, slot or opening in the outer sleeve 7. The locking sleeve
16 has a number of cams 17 on the inside designed to intervene in the tracks 15 on the
telescopic sleeve, and also include a threaded section 18 on the outside, and locking
knobs 19. Furthermore, there is a locking ring 20 that is oriented to be turned on the

locking sleeve 16 and the clamp locking knobs 19 against the telescopic sleeve 11 when the telescopic column is locked in a particular length. The other details shown in the figure may include end caps 21, 22 which act as bearings for the rotary movement, as well as the bushings 23, 24, 25.

- 5 Figure 3 shows the mechanism in the mounted condition, ready to be put into the outer casing and locked to it.

In a simpler version of the PC table, it is conceivable that the telescopic column is arranged directly between the clamp attachment 6 and attached to the table top 1.

- 10 The telescopic column according to the invention has been described applied to a PC table. However, it may find other applications, such as in a rotating mechanism for the seat on a chair, or other general applications outside the furniture industry.

Claims
(Amended 19 August 2011)

1. Rotating telescopic column, comprising:
an outer sleeve (7),
- 5 a telescopic sleeve (11) located inside the outer sleeve (7),
a lockable clamp mechanism that is attached to the outer sleeve (7) and grips the telescopic sleeve (11) and is designed to lock the telescopic sleeve to the outer sleeve when the telescopic sleeve is in a selected position relative to the outer sleeve,
- 10 a shaft (10) located inside the telescopic sleeve (11) and which is rotatable in relation to this,
c h a r a c t e r i z e d i n that the outer sleeve has a number of internal cams, said telescopic sleeve has a corresponding number of outer slots (15), as the
15 cams in the outer sleeve (7) are designed to intervene in the slots (15) in the telescopic sleeve (11) and thereby prevent the telescopic sleeve from turning relative to the outer sleeve.
2. Rotating telescopic column according to claim 1, where the lockable clamping mechanism includes a locking sleeve (16) with a number of locking knobs (19), as the locking sleeve (16) is attached to the outer sleeve (7), and a locking
20 ring (20) arranged to clamp the locking tabs (19) against the telescopic sleeve (11).
3. Rotating telescopic column according to claim 1, as it further includes a number of spring washers (12) arranged between a screw head (13) on shaft (10) and one end of the telescopic sleeve (11), and which serves to determine the
25 friction between the shaft and telescopic sleeve.
4. Rotating telescopic column according to claim 1, as it further includes first (21) and second (22) end caps mounted on the ends of the telescopic sleeve (11) and acts as bearings for the axle (10).
5. Rotating telescopic column according to claim 1, where the telescopic sleeve
30 consists of an outer and an inner tube connected by a number of longitudinal bridges.

4

6. PC table comprising a table top (1) and a fastening mechanism such as a clamp attachment (6), having a rotatable telescopic column according to one of claims 1 - 5 is arranged between the table top and the fastening mechanism.

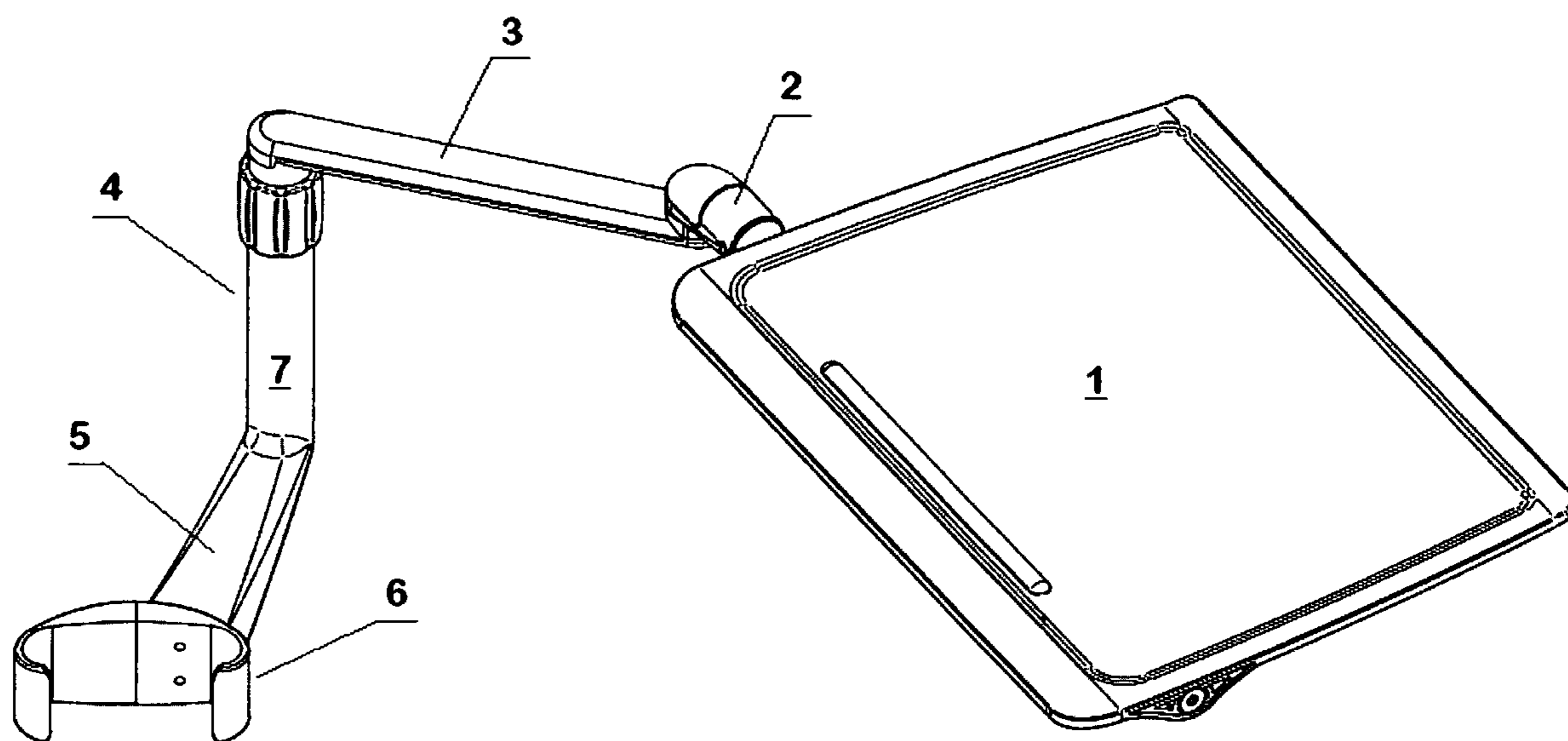

Fig. 1

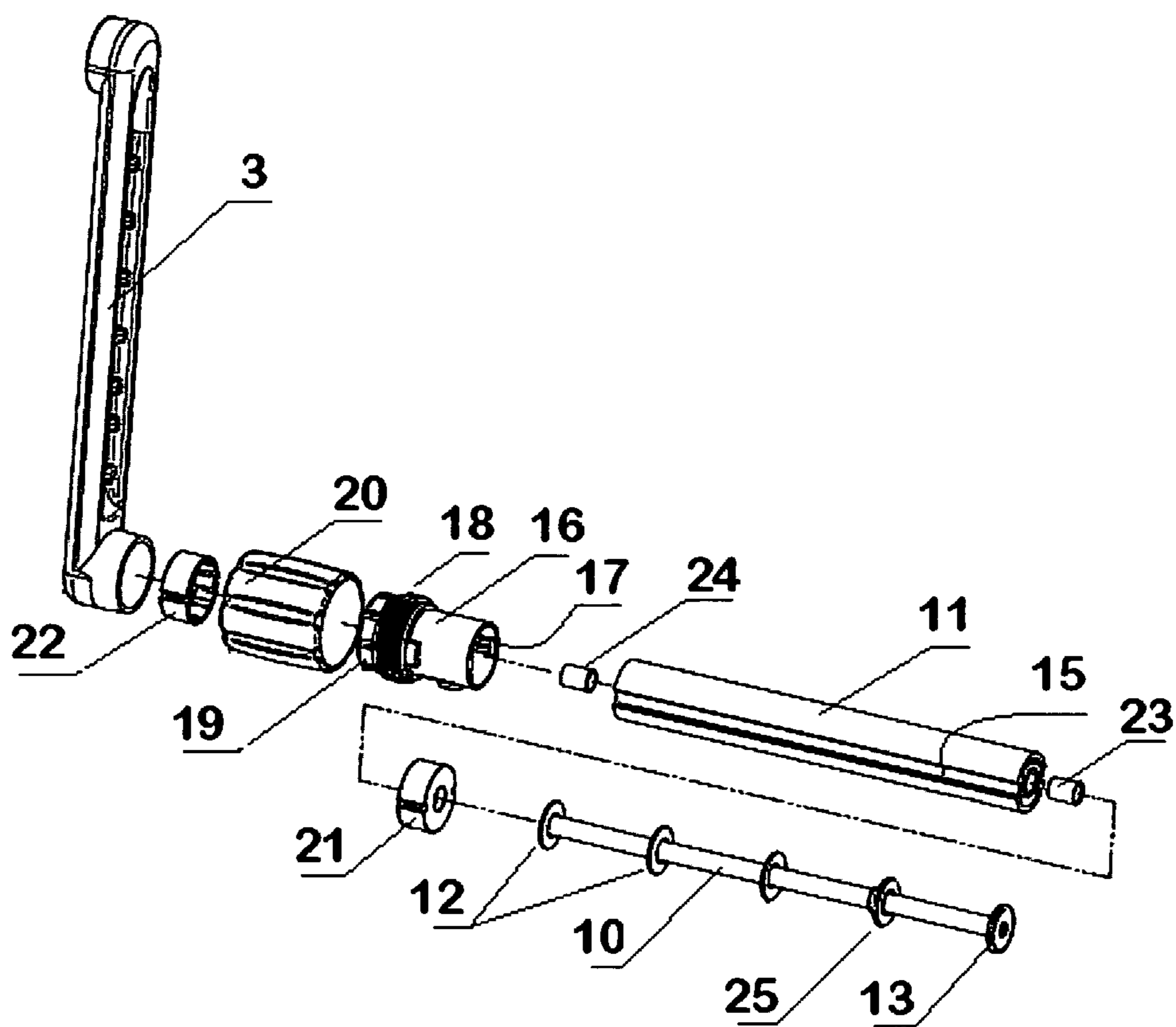

Fig. 2

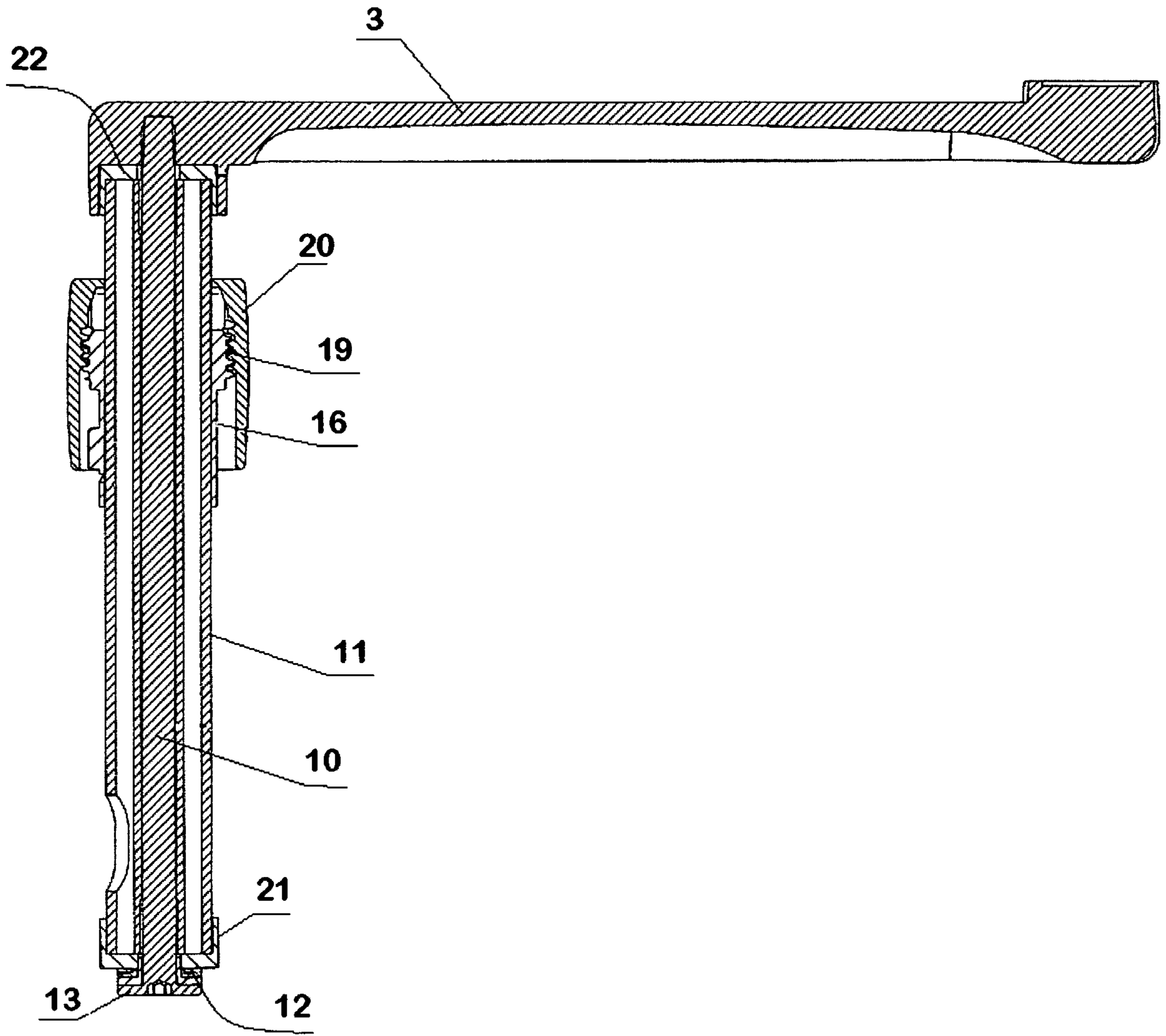

Fig. 3

