



## INTERNATIONAL APPLICATION PUBLISHED UNDER THE PATENT COOPERATION TREATY (PCT)

<b>(51) International Patent Classification <sup>6</sup> :</b> <b>H04R 25/00, G02C 11/06</b>	<b>A1</b>	<b>(11) International Publication Number:</b> <b>WO 99/21400</b> <b>(43) International Publication Date:</b> 29 April 1999 (29.04.99)
<p><b>(21) International Application Number:</b> PCT/NL98/00602</p> <p><b>(22) International Filing Date:</b> 20 October 1998 (20.10.98)</p> <p><b>(30) Priority Data:</b>          1007321                      20 October 1997 (20.10.97)                      NL</p> <p><b>(71) Applicants (for all designated States except US):</b> TECHNISCHE UNIVERSITEIT DELFT [NL/NL]; P.O. Box 5046, NL-2600 GA Delft (NL). STICHTING VOOR DE TECHNISCHE WETENSCHAPPEN [NL/NL]; P.O. Box 3021, NL-3502 GA Utrecht (NL).</p> <p><b>(72) Inventors; and</b>  <b>(75) Inventors/Applicants (for US only):</b> BOONE, Marinus, Marias [NL/NL]; Voorweg 105A, NL-2715 NG Zoetermeer (NL). BERKHOUT, Augustinus, Johannes [NL/NL]; Nieuwe Parklaan 30, NL-2597 LD Den Haag (NL). MERKS, Ivo, Léon, Diane, Marie [NL/NL]; Dakarhof 56, NL-2622 CR Delft (NL).</p> <p><b>(74) Agent:</b> DE BRUIJN, Leendert, C.; Nederlandsch Octrooibureau, Scheveningseweg 82, P.O. Box 29720, NL-2502 LS The Hague (NL).</p>		<p><b>(81) Designated States:</b> AL, AM, AT, AU, AZ, BA, BB, BG, BR, BY, CA, CH, CN, CU, CZ, DE, DK, EE, ES, FI, GB, GD, GE, GH, GM, HR, HU, ID, IL, IS, JP, KE, KG, KP, KR, KZ, LC, LK, LR, LS, LT, LU, LV, MD, MG, MK, MN, MW, MX, NO, NZ, PL, PT, RO, RU, SD, SE, SG, SI, SK, SL, TJ, TM, TR, TT, UA, UG, US, UZ, VN, YU, ZW, ARIPO patent (GH, GM, KE, LS, MW, SD, SZ, UG, ZW), Eurasian patent (AM, AZ, BY, KG, KZ, MD, RU, TJ, TM), European patent (AT, BE, CH, CY, DE, DK, ES, FI, FR, GB, GR, IE, IT, LU, MC, NL, PT, SE), OAPI patent (BF, BJ, CF, CG, CI, CM, GA, GN, GW, ML, MR, NE, SN, TD, TG).</p> <p><b>Published</b>  <i>With international search report.</i>  <i>In English translation (filed in Dutch).</i></p>

**(54) Title:** HEARING AID COMPRISING AN ARRAY OF MICROPHONES

**(57) Abstract**

Hearing aid for improving the hearing ability of the hard of hearing, comprising an array of microphones, the electrical output signals of which are fed to at least one transmission path belonging to an ear. Means are provided for deriving two array output signals from the output signals of the microphones, the array having two main sensitivity directions running at an angle with respect to one another and each of which is associated to an array output signal. Each array output signal is fed to its own transmission path belonging to one ear of a person who is hard of hearing.

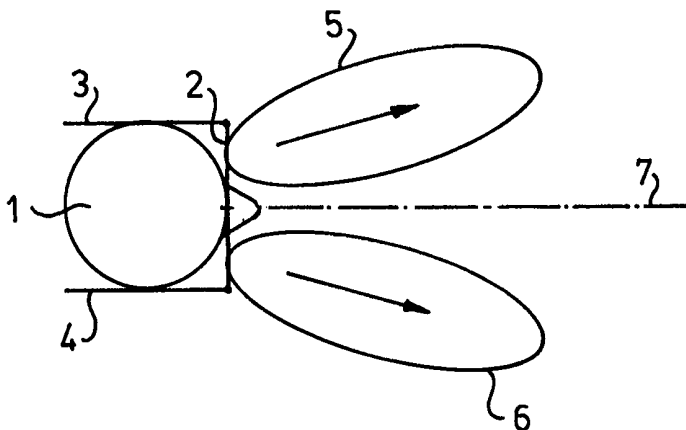

**FOR THE PURPOSES OF INFORMATION ONLY**

Codes used to identify States party to the PCT on the front pages of pamphlets publishing international applications under the PCT.

<b>AL</b>	Albania	<b>ES</b>	Spain	<b>LS</b>	Lesotho	<b>SI</b>	Slovenia
<b>AM</b>	Armenia	<b>FI</b>	Finland	<b>LT</b>	Lithuania	<b>SK</b>	Slovakia
<b>AT</b>	Austria	<b>FR</b>	France	<b>LU</b>	Luxembourg	<b>SN</b>	Senegal
<b>AU</b>	Australia	<b>GA</b>	Gabon	<b>LV</b>	Latvia	<b>SZ</b>	Swaziland
<b>AZ</b>	Azerbaijan	<b>GB</b>	United Kingdom	<b>MC</b>	Monaco	<b>TD</b>	Chad
<b>BA</b>	Bosnia and Herzegovina	<b>GE</b>	Georgia	<b>MD</b>	Republic of Moldova	<b>TG</b>	Togo
<b>BB</b>	Barbados	<b>GH</b>	Ghana	<b>MG</b>	Madagascar	<b>TJ</b>	Tajikistan
<b>BE</b>	Belgium	<b>GN</b>	Guinea	<b>MK</b>	The former Yugoslav Republic of Macedonia	<b>TM</b>	Turkmenistan
<b>BF</b>	Burkina Faso	<b>GR</b>	Greece	<b>ML</b>	Mali	<b>TR</b>	Turkey
<b>BG</b>	Bulgaria	<b>HU</b>	Hungary	<b>MN</b>	Mongolia	<b>TT</b>	Trinidad and Tobago
<b>BJ</b>	Benin	<b>IE</b>	Ireland	<b>MR</b>	Mauritania	<b>UA</b>	Ukraine
<b>BR</b>	Brazil	<b>IL</b>	Israel	<b>MW</b>	Malawi	<b>UG</b>	Uganda
<b>BY</b>	Belarus	<b>IS</b>	Iceland	<b>MX</b>	Mexico	<b>US</b>	United States of America
<b>CA</b>	Canada	<b>IT</b>	Italy	<b>NE</b>	Niger	<b>UZ</b>	Uzbekistan
<b>CF</b>	Central African Republic	<b>JP</b>	Japan	<b>NL</b>	Netherlands	<b>VN</b>	Viet Nam
<b>CG</b>	Congo	<b>KE</b>	Kenya	<b>NO</b>	Norway	<b>YU</b>	Yugoslavia
<b>CH</b>	Switzerland	<b>KG</b>	Kyrgyzstan	<b>NZ</b>	New Zealand	<b>ZW</b>	Zimbabwe
<b>CI</b>	Côte d'Ivoire	<b>KP</b>	Democratic People's Republic of Korea	<b>PL</b>	Poland		
<b>CM</b>	Cameroon	<b>KR</b>	Republic of Korea	<b>PT</b>	Portugal		
<b>CN</b>	China	<b>KZ</b>	Kazakstan	<b>RO</b>	Romania		
<b>CU</b>	Cuba	<b>LC</b>	Saint Lucia	<b>RU</b>	Russian Federation		
<b>CZ</b>	Czech Republic	<b>LI</b>	Liechtenstein	<b>SD</b>	Sudan		
<b>DE</b>	Germany	<b>LK</b>	Sri Lanka	<b>SE</b>	Sweden		
<b>DK</b>	Denmark	<b>LR</b>	Liberia	<b>SG</b>	Singapore		
<b>EE</b>	Estonia						

## HEARING AID COMPRISING AN ARRAY OF MICROPHONES

The invention relates to a hearing aid for improving the  
5 hearing ability of the hard of hearing, comprising an array of  
microphones, the electrical output signals of which are fed to  
at least one transmission path belonging to an ear.

A device of this type is known from the article entitled  
"Development of a directional hearing instrument based on array  
10 technology" published in the "Journal of the Acoustical Society  
of America", Vol. 94, Edition 2, Pt. 1, pages 785-798, August  
1993.

It is generally known that loss of hearing in people can be  
compensated for by means of a hearing aid, in which  
15 amplification of the received sound is used. In environments  
with background noise, for example when several people are  
speaking at once, as is the case at a cocktail party, the  
hearing aid amplifies both the desired speech and the noise, as  
a result of which the ability to hear is not improved.

20 In the abovementioned article the authors describe an  
improvement proposal. The hearing aid disclosed in the article  
consists of an array of, for example, five directional  
microphones, as a result of which it is possible for the person  
who is hard of hearing to understand someone who is speaking  
25 directly opposite him or her. The background noise which  
emanates from other directions is suppressed by the array.

The aim of the invention is to provide a hearing aid of the  
type mentioned in the preamble with which the abovementioned  
disadvantages are avoided and the understandability and the  
30 naturalness of the reproduction is improved in a simple manner.

Said aim is achieved according to the invention in that  
means are provided for deriving two array output signals from  
the output signals of the microphones, the array having two  
main sensitivity directions running at an angle with respect to  
35 one another and each of which is associated to an array output  
signal, and in that each array output signal is fed to its own  
transmission path belonging to one ear of a person who is hard  
of hearing.

With this arrangement the signals from the microphones of the array are combined to give a signal for the left ear and a signal for the right ear. The array has two main sensitivity directions or main lobes running at an angle with respect to one another, the left ear signal essentially representing the sound originating from the first main sensitivity direction and the right ear signal representing that from the other main sensitivity direction. The array output signals, that is to say the left ear signal and the right ear signal, are fed via their own transmission path to the left ear and the right ear, respectively. Amplification of the signal and conversion of the electrical signal into a sound signal is employed in said transmission path.

The different main lobes introduce a difference in level between the signals to be fed to the ears. It has been found that it is not only possible to localise sound sources better, but that background noise is also suppressed as a result of the directional effect, as a result of which the understandability of speech is improved despite the existing noise.

The array can advantageously be mounted on the front of a spectacle frame and/or on the arms or springs.

In the case of an embodiment which is preferably to be used, each spectacle arm is also provided with an array of microphones, the output signals from the one array being fed to the one transmission path and the output signals from the other array being fed to the other transmission path.

What is achieved by this means is that understandability is improved not only at high frequencies in the audible sound range but also at relatively low frequencies.

Further embodiments of the invention are described in the subsidiary claims.

The invention will be explained in more detail below with reference to the drawings. In the drawings:

Figure 1 shows an embodiment of the hearing aid according to the invention;

Figure 2 shows a more detailed embodiment of the hearing aid according to the invention;

Figure 3 shows another embodiment of the hearing aid according

to the invention;

Figure 4 shows an embodiment of the hearing aid according to Figure 4 in which a combination of arrays is used, which embodiment is preferably to be used;

5 Figure 5 shows a polar diagram of a combined array from Figure 1 at 500 and 1000 Hz;

Figure 6 shows a polar diagram of an embodiment from Figure 1 at 2000 and 4000 Hz; and

Figure 7 shows the directional index of the embodiment in  
10 Figure 4 as a function of the frequency.

The hearing aid according to the invention comprises an array of microphones. Said array can have any shape.

Said array has two array output signals which are each fed along their own transmission path, one to the left ear and the  
15 other to the right ear of the person hard of hearing. In said transmission path amplification and conversion of the electrical signal from the array to sound vibrations are employed in the conventional manner.

The array has two main sensitivity directions running at an  
20 angle with respect to one another, the various features being such that the first array output signal is essentially a reflection of the sound from the first main sensitivity direction, whilst the second array output signal essentially represents the sound from the second main sensitivity  
25 direction. As a result the left ear as it were listens in a restricted first main sensitivity direction, whilst the right ear listens in the second main sensitivity direction.

The main sensitivity directions associated with the array output signals can be achieved by focusing or bundling the  
30 microphone signals.

The array of microphones can be attached in a simple manner to spectacle frames. Figure 1 shows an embodiment of an array of microphones on the front of the spectacle frames, bundling being employed.

35 In Figure 1 the head of a person hard of hearing is indicated diagrammatically by reference numeral 1. The spectacles worn by this person are shown diagrammatically by straight lines, which spectacles consist, in the conventional

manner, of a front 2 and two spectacle arms or springs 3, 4.

The main lobe 5 for the left ear and the main lobe 6 for the right ear are also shown in Figure 1 as ellipses. Said main lobes are at an angle with respect to one another and with respect to the main axis 7 of the spectacles.

As a result of the main lobes used above and the separate assignment thereof to the ears, a difference between the level of the array output signals is artificially introduced depending on the location of the sound source and also for the noise. As a result of said artificial difference in the levels of the array output signals, the person hard of hearing is able to localise the sound source, but it has been found that said difference also improves the understandability of speech in the presence of noise.

Positioning the array of microphones on one or both of the spectacle arms is also advantageous.

The association of the array output signals to the associated main lobes of the array can be achieved in a simple manner by means of a so-called parallel or serial construction.

In the case of the parallel construction, the means for deriving the array output signals comprise a summing device, the microphone output signals being fed to the inputs of said summing device via a respective frequency-dependent or frequency-independent weighting factor device. An array output signal can then be taken off at the output of the summing device. A main sensitivity direction associated with the relevant array output signal can be obtained by sizing the weighting factor devices.

In the case of the so-called serial construction, the means for deriving the array output signals contain a number of summing devices and weighting factor devices, the weighting factor devices in each case being connected in series with the input and output of the summing devices. With this arrangement one outermost microphone is connected to an input of a weighting factor device, the output of which is then connected to an input of a summing device. The output of the microphone adjacent to the said outermost microphone is connected to the input of the summing device. The output of the summing device

is connected to the input of the next weighting factor device, the output of which is connected to the input of the next summing device. The output of the next microphone is, in turn, connected to the other input of this summing device.

5 This configuration is continued as far as the other outermost microphone of the array. An array output signal, for example the left ear signal, can be taken off from the output of the last summing device, the input of which is connected to the output of the last-mentioned outermost microphone. It could  
10 also be possible to derive the array output signal from the output of the said last summing device via a further weighting factor device.

In a further development, the weighting factor device comprises a delay device, optionally supplemented by an  
15 amplitude-adjustment device.

In another development, the weighting factor device consists of a phase adjustment device, optionally supplemented by an amplitude-adjustment device.

Figure 2 shows the parallel construction with delay  
20 devices. The microphones 8, 9, 10, 11 and 12 are shown on the right of Figure 2, which microphones are connected by a line in the drawing to indicate that it is an array that is concerned here. The outputs of the microphones 8-12 are connected to the inputs of the respective delay devices 13, 14, 15, 16 and 17.  
25 The outputs of said delay devices 13-17 are connected to the inputs of the summing device 18, at the output of which an array output signal, for example a left ear signal, can be derived. An amplitude-adjustment device, which can consist of an amplifier or a attenuator, can be incorporated, in a manner  
30 which is not shown, in each path between a microphone and an input of the summing device. Preferably, the signal of the  $n^{\text{th}}$  microphone is delayed by a period  $n\tau_t$ . Figure 2 shows that the output signal from the microphone 8 is fed to the input of the summing device 18 with a delay period 0, whilst the output  
35 signal from the microphone 9 is fed to the next input of the summing device 18 with a delay  $\tau_t$ . The corresponding delays apply in the case of the microphones 10, 11 and 12; that is to say delay periods of  $2\tau_t$ ,  $3\tau_t$  and  $4\tau_t$  respectively. The delay

period  $\tau_t$  is chosen such that sound emanating from the direction which makes an angle of  $\theta$  with respect to the main axis of the array is summed in phase. Then:  $\tau_t = d \sin \theta / c$ , where  $d$  is the distance between two microphones and  $c$  is the wave propagation rate.

A similar arrangement can be designed for the right ear signal.

Figure 3 shows the so-called serial construction with delay devices.

In the case of this embodiment shown a series circuit of 4 delay devices 18-21 and 4 summing devices 22-24 is used. The delay devices and summing devices are connected alternately in series. The microphone 12 is connected to the input of the delay device 21, whilst the outputs of the microphones 8-11 are connected to the respective summing devices 23-26.

With this embodiment as well the signal from the microphone 12 is delayed by a delay period of 4 times  $\tau_t$ , if each delay device produces a delay of  $\tau_t$ . After adding in the summing device 26, the output signal from the microphone 11 is delayed by a delay period of 3 times  $\tau_t$ . Corresponding delays apply in respect of the microphones 9 and 10. The output signal from the microphone 8 is not delayed. If desired, a further delay device can be incorporated behind the summing device 23.

With this so-called serial construction as well it is possible to incorporate amplitude-adjustment devices in the form of amplifiers or attenuators in each part of the series circuit, each amplitude-adjustment device being associated with an output signal from a specific microphone in the array. The delay device used can simply be an all-pass filter of the first order, which can be adjusted by means of a potentiometer.

A microphone array 14 cm long can be used as a practical embodiment. As a consequence of the means described above for deriving the output signals from the microphones which are each associated with one main sensitivity direction, the microphones used can be very simple microphones of omnidirectional sensitivity. If desired, cardioid microphones can be used to obtain additional directional sensitivity.

If the angle between the two main sensitivity directions or



main lobes becomes greater, the difference between the audible signals, i.e. the inter-ear level difference, will become greater. Consequently the localisability will in general become better.

5           However, as the said angle between the main lobes becomes greater, the attenuation of a sound signal will increase in the direction of a main axis of the array. The choice of the angle between the main lobes will thus, in practice, be a compromise between a good inter-ear level difference and an acceptable  
10           attenuation in the main direction of the array. This choice will preferably be determined experimentally.

          Furthermore, on enlarging the angle between the main lobes, the main lobes will each be split into two lobes beyond a certain angle. This phenomenon can be avoided by use of an  
15           amplitude-weighting function for the microphone signals.

          In the case of an embodiment of the invention that is preferably to be used, an array attached to the front of the spectacle frames and two arrays, each attached to one arm of the spectacles, are used. An example with eleven microphones is  
20           shown in Figure 4. The microphones 26, 27 and 28, which form the left array, are attached to the left arm of the spectacles and the microphones 34, 35 and 36 of the right array are attached to the right arm of the spectacles. The microphones 29-33 are attached to the front of the spectacle frames.

25           The signals from the microphones 29-33 are fed in the manner described above to the transmission paths for the left and the right ear, respectively. The signals from the microphones 26, 27, 28 are coupled to the transmission path for the left ear, whilst the signals from the microphones 34-36 are  
30           fed via the other transmission path to the right ear.

          At high frequencies an inter-ear level difference is created with the aid of bundling the array at the front of the spectacle frames and the shadow effect of the arrays on the arms of the spectacles has an influence. At low frequencies an  
35           inter-ear time difference is created by means of the arrays on the arms of the spectacles. An inter-ear time difference is defined as the difference in arrival time between the signals at the ears as a consequence of the difference in propagation

time.

Figure 5 shows the directional characteristics of the combination of arrays in Figure 4 at a frequency of 500 Hz, indicated by a dash-and-dot line, and at 1000 Hz, indicated by a continuous line. The directional characteristics in Figure 5 are obtained with the arrays on the arms of the spectacles. The array on the front of the spectacles is thus switched off since it yields little additional directional effect at low frequencies. In this way an inter-ear time difference is thus created.

Figure 6 shows the directional characteristics of the combination of arrays at 2000 Hz, indicated by a dash-and-dot line, and at 4000 Hz, indicated by a continuous line. In the mid and high frequency region of the audible sound range the main lobes are directed at  $11^\circ$ , so that once again an inter-ear level difference is created.

Figure 7 shows the directivity index as a function of the frequency for 3 optimised frequency ranges. The continuous line applies for the low frequencies, optimised at 500 Hz. The broken line applies for optimisation at 4000 Hz and the dash-and-dot line for optimisation at 2300 Hz.

It is also pointed out that an inter-ear level difference can also be produced with the arrays on the arms of the spectacles as with the array on the front of the spectacle frames.

## CLAIMS

1. Hearing aid for improving the hearing ability of the hard of hearing, comprising an array of microphones, the electrical output signals of which are fed to at least one transmission path belonging to an ear, characterised in that means are provided for deriving two array output signals from the output signals of the microphones, the array having two main sensitivity directions running at an angle with respect to one another and each of which is associated to an array output signal, and in that each array output signal is fed to its own transmission path belonging to one ear of a person who is hard of hearing.

2. Hearing aid according to Claim 1, characterised in that the array is mounted on the front of a pair of spectacles.

3. Hearing aid according to Claim 1 or 2, characterised in that the array is mounted on an arm of a pair of spectacles.

4. Hearing aid according to Claim 2, characterised in that each arm of the spectacles is provided with an array of microphones and in that the output signals from said arrays are each fed to the one or, respectively, the other transmission path.

5. Hearing aid according to Claim 1, 2, 3, or 4, characterised in that the means for deriving the array output signals contain a summing device, from the output of which an array output signal can be taken off and to the inputs of which the microphone output signals are fed via a respective weighting factor device.

6. Hearing aid according to Claim 1, 2, 3 or 4, characterised in that the means for deriving the array output signals contain a series circuit of a number of summing devices and weighting factor devices, the outputs of the microphones arranged between the two outermost microphones being connected to the other inputs of the summing devices, which other inputs are not connected to a weighting factor device, in that one of the outermost microphones of the array is connected via a weighting factor device to the input of the summing device associated with the adjacent microphone and in that the input

of a weighting factor device is connected to the output of the summing device of the microphone adjacent to the other outermost microphone, the one input of a summing device being connected to the output of said weighting factor device, the  
5 output of the last-mentioned microphone being connected to the other input of the summing device and it being possible to derive an array output signal at the output of the summing device.

7. Hearing aid according to Claim 6, characterised in that  
10 the array output signal is derived via a further weighting factor device.

8. Hearing aid according to Claim 5, 6 or 7, characterised in that the weighting factor device comprises a delay device.

9. Hearing aid according to Claim 8, characterised in that  
15 the weighting factor device comprises an amplitude-adjustment device.

10. Hearing aid according to Claim 5, 6 or 7, characterised in that the weighting factor device comprises a phase-adjustment device.

20 11. Hearing aid according to Claim 10, characterised in that the weighting factor device comprises an amplitude-adjustment device.

fig-1

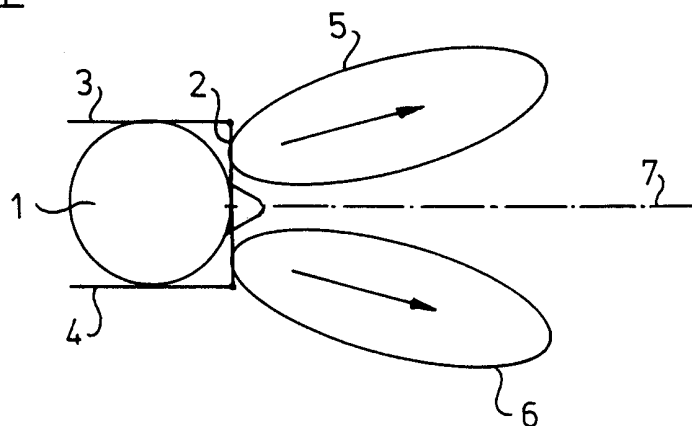

fig-2

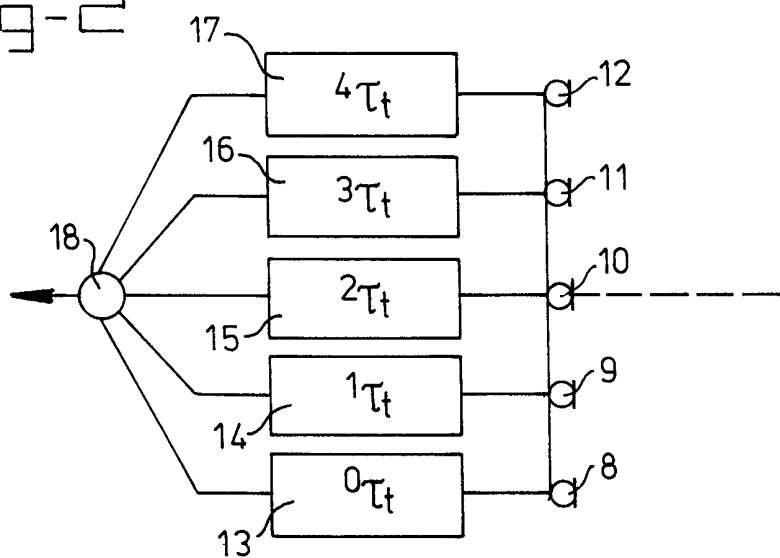

fig-3

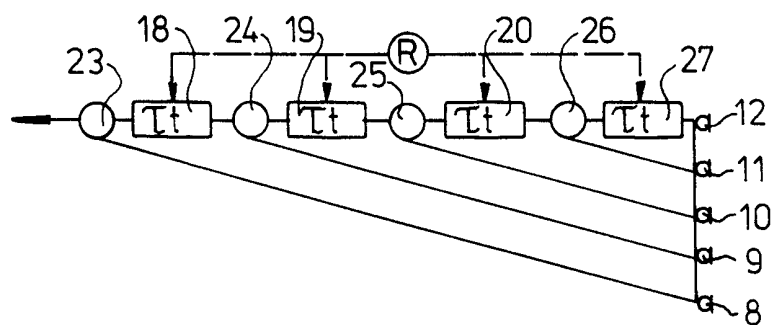

fig - 4

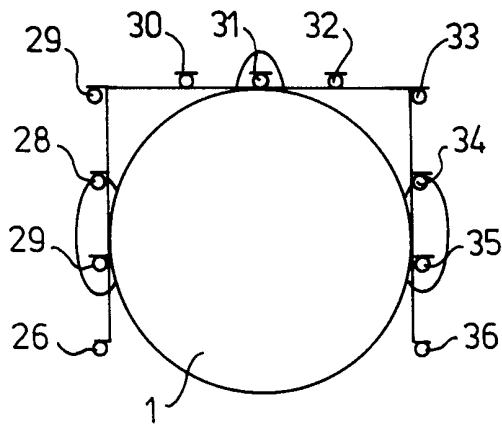

fig - 5

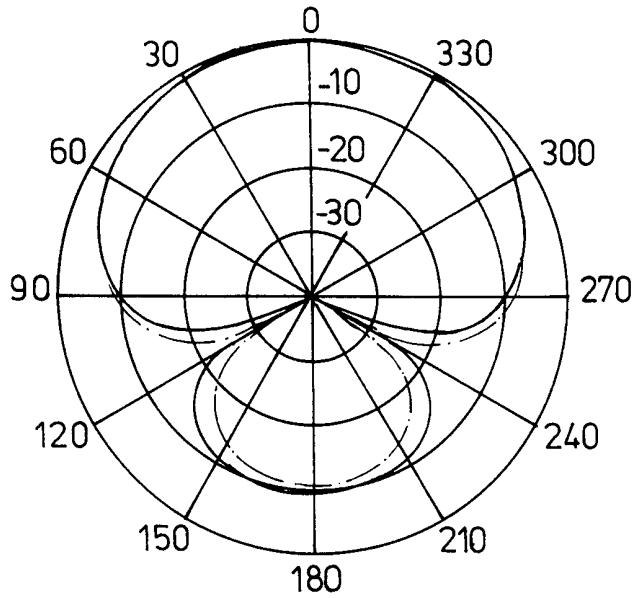

fig - 6

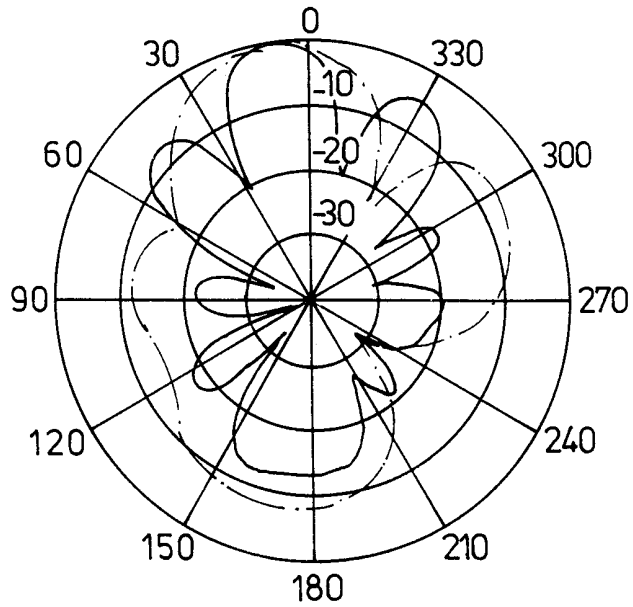
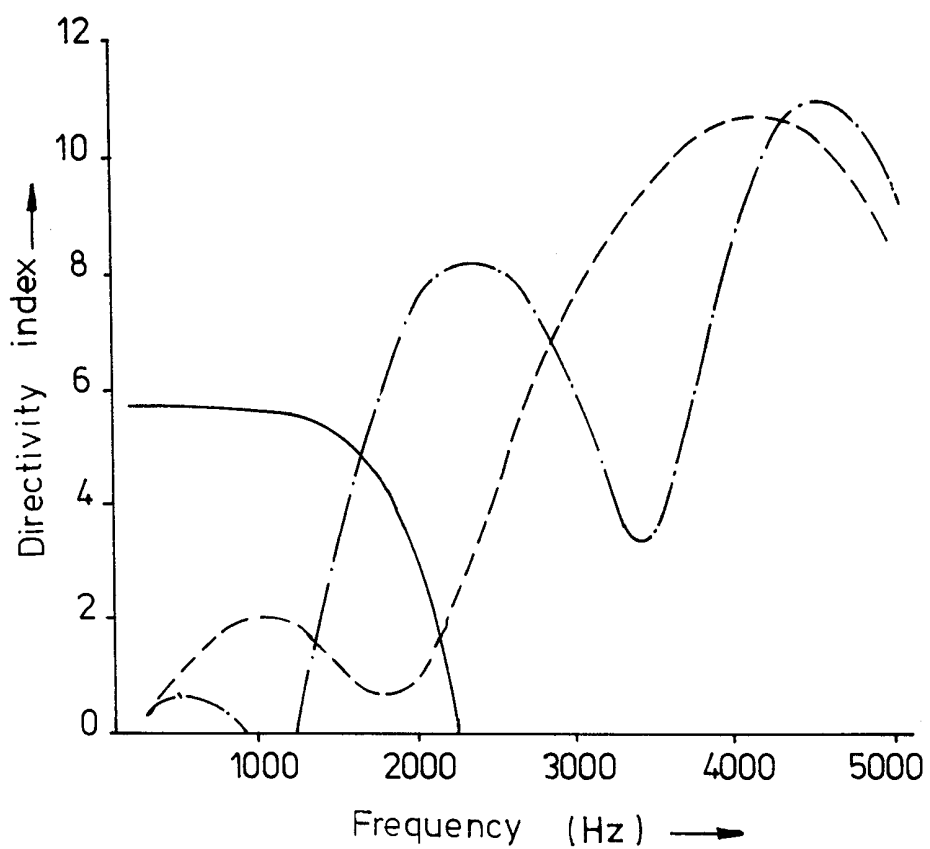

fig-7



# INTERNATIONAL SEARCH REPORT

International Application No  
PCT/NL 98/00602

<b>A. CLASSIFICATION OF SUBJECT MATTER</b> IPC 6 H04R25/00 G02C11/06				
According to International Patent Classification (IPC) or to both national classification and IPC				
<b>B. FIELDS SEARCHED</b>				
Minimum documentation searched (classification system followed by classification symbols) IPC 6 H04R G02C				
Documentation searched other than minimum documentation to the extent that such documents are included in the fields searched				
Electronic data base consulted during the international search (name of data base and, where practical, search terms used)				
<b>C. DOCUMENTS CONSIDERED TO BE RELEVANT</b>				
Category °	Citation of document, with indication, where appropriate, of the relevant passages	Relevant to claim No.		
A	SOEDE W ET AL: "DEVELOPMENT OF A DIRECTIONAL HEARING INSTRUMENT BASED ON ARRAY TECHNOLOGY" JOURNAL OF THE ACOUSTICAL SOCIETY OF AMERICA, vol. 94, no. 2 PART 01, 1 August 1993, pages 785-798, XP000387744 cited in the application see the whole document ---	1		
A	US 5 483 599 A (ZAGORSKI MICHAEL A) 9 January 1996 see column 5, line 27 - line 47; figure 8 ---	1		
A	US 5 511 128 A (LINDEMANN ERIC) 23 April 1996 see column 2, line 35 - column 4, line 19; figures ---	1		
-/--				
<input checked="" type="checkbox"/> Further documents are listed in the continuation of box C.				
<input checked="" type="checkbox"/> Patent family members are listed in annex.				
° Special categories of cited documents :				
<table style="width: 100%; border: none;"> <tr> <td style="width: 50%; border: none; vertical-align: top;">                     "A" document defining the general state of the art which is not considered to be of particular relevance                      "E" earlier document but published on or after the international filing date                      "L" document which may throw doubts on priority claim(s) or which is cited to establish the publication date of another citation or other special reason (as specified)                      "O" document referring to an oral disclosure, use, exhibition or other means                      "P" document published prior to the international filing date but later than the priority date claimed                 </td> <td style="width: 50%; border: none; vertical-align: top;">                     "T" later document published after the international filing date or priority date and not in conflict with the application but cited to understand the principle or theory underlying the invention                      "X" document of particular relevance; the claimed invention cannot be considered novel or cannot be considered to involve an inventive step when the document is taken alone                      "Y" document of particular relevance; the claimed invention cannot be considered to involve an inventive step when the document is combined with one or more other such documents, such combination being obvious to a person skilled in the art.                      "&amp;" document member of the same patent family                 </td> </tr> </table>			"A" document defining the general state of the art which is not considered to be of particular relevance "E" earlier document but published on or after the international filing date "L" document which may throw doubts on priority claim(s) or which is cited to establish the publication date of another citation or other special reason (as specified) "O" document referring to an oral disclosure, use, exhibition or other means "P" document published prior to the international filing date but later than the priority date claimed	"T" later document published after the international filing date or priority date and not in conflict with the application but cited to understand the principle or theory underlying the invention "X" document of particular relevance; the claimed invention cannot be considered novel or cannot be considered to involve an inventive step when the document is taken alone "Y" document of particular relevance; the claimed invention cannot be considered to involve an inventive step when the document is combined with one or more other such documents, such combination being obvious to a person skilled in the art. "&" document member of the same patent family
"A" document defining the general state of the art which is not considered to be of particular relevance "E" earlier document but published on or after the international filing date "L" document which may throw doubts on priority claim(s) or which is cited to establish the publication date of another citation or other special reason (as specified) "O" document referring to an oral disclosure, use, exhibition or other means "P" document published prior to the international filing date but later than the priority date claimed	"T" later document published after the international filing date or priority date and not in conflict with the application but cited to understand the principle or theory underlying the invention "X" document of particular relevance; the claimed invention cannot be considered novel or cannot be considered to involve an inventive step when the document is taken alone "Y" document of particular relevance; the claimed invention cannot be considered to involve an inventive step when the document is combined with one or more other such documents, such combination being obvious to a person skilled in the art. "&" document member of the same patent family			
Date of the actual completion of the international search  <div style="text-align: center; font-weight: bold;">29 January 1999</div>		Date of mailing of the international search report  <div style="text-align: center; font-weight: bold;">05/02/1999</div>		
Name and mailing address of the ISA European Patent Office, P.B. 5818 Patentlaan 2 NL - 2280 HV Rijswijk Tel. (+31-70) 340-2040, Tx. 31 651 epo nl, Fax: (+31-70) 340-3016		Authorized officer  <div style="text-align: center; font-weight: bold;">Gastaldi, G</div>		



# INTERNATIONAL SEARCH REPORT

International Application No  
PCT/NL 98/00602

C.(Continuation) DOCUMENTS CONSIDERED TO BE RELEVANT		
Category °	Citation of document, with indication, where appropriate, of the relevant passages	Relevant to claim No.
A	US 4 956 867 A (ZUREK PATRICK M ET AL) 11 September 1990 see column 2, line 12 - column 3, line 14; figures -----	1

# INTERNATIONAL SEARCH REPORT

Information on patent family members

International Application No

PCT/NL 98/00602

Patent document cited in search report	Publication date	Patent family member(s)	Publication date
US 5483599 A	09-01-1996	US 5243660 A CA 2097136 A	07-09-1993 29-11-1993
US 5511128 A	23-04-1996	AU 1833395 A EP 0740893 A WO 9520305 A	08-08-1995 06-11-1996 27-07-1995
US 4956867 A	11-09-1990	WO 9013215 A	01-11-1990