



Europäisches Patentamt  
European Patent Office  
Office européen des brevets



Publication number: **0 401 996 A3**

**EUROPEAN PATENT APPLICATION**

Application number: **90305432.8**

Int. Cl.<sup>5</sup>: **B41J 2/05, B41J 2/16**

Date of filing: **18.05.90**

Priority: **08.06.89 IT 6745889**

Applicant: **Ing. C. Olivetti & C., S.p.A.**  
**Via G. Jervis 77**  
**I-10015 Ivrea(IT)**

Date of publication of application:  
**12.12.90 Bulletin 90/50**

Inventor: **Conta, Renato**  
**Via Lago, S Michele 12**  
**I-10015 Ivrea(IT)**

Designated Contracting States:  
**DE FR GB**

Date of deferred publication of the search report:  
**04.12.91 Bulletin 91/49**

Representative: **Abnett, Richard Charles et al**  
**REDDIE & GROSE 16 Theobalds Road**  
**London WC1X 8PL(GB)**

**Process for the manufacture of thermal ink jet printing heads and heads obtained in this way.**

Each thermal ink jet printing head (1) comprises a multi-layer plate in which layers of metals and of insulating materials are successively deposited under vacuum on a silicon base plate (20). The ink is contained in expulsion chambers (4) formed by a photolithographic process in a layer of photosensitive resin (74) and is expelled by the effect of rapid heating of resistive elements (8) contained within the expulsion chambers through nozzles (5) disposed in

two rows side by side and produced in a metal lamina stuck to the resin layer. The expulsion chambers communicate with a main reservoir through a common ink feed duct (14) in the form of a slot or groove disposed between the two rows of nozzles and cut through the silicon plate (20) partly by an etching process and partly by a sandblasting process or with a special type of laser (excimer).

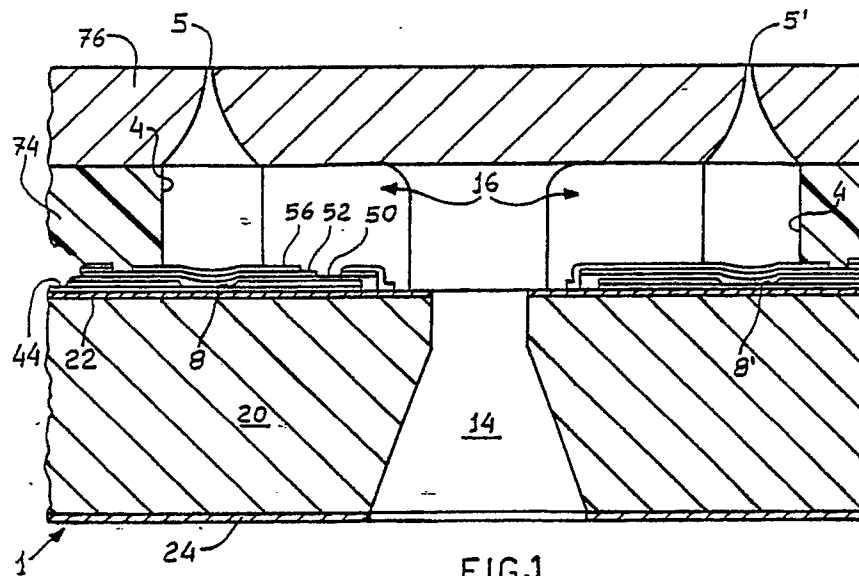

**EP 0 401 996 A3**



DOCUMENTS CONSIDERED TO BE RELEVANT			EP 90305432.8
Category	Citation of document with indication, where appropriate, of relevant passages	Relevant to claim	CLASSIFICATION OF THE APPLICATION (Int. Cl.5)
A	<u>US - A - 4 789 425</u> (DRAKE) * Totality * --	1-3, 9-16	B 41 J 2/16 B 41 J 2/05
A	<u>US - A - 4 835 553</u> (TORPEY) * Totality * --	1-3, 9-16	
A	<u>EP - A2 - 0 197 723</u> (XEROX CORP.) * Totality * --	1-3, 9-16	
A	<u>EP - A2 - 0 224 937</u> (HEWLETT-PACKARD) * Totality * -----	16	
			<b>TECHNICAL FIELDS SEARCHED (Int. Cl.5)</b>
			B 41 J G 01 D
The present search report has been drawn up for all claims			
Place of search VIENNA	Date of completion of the search 01-10-1991	Examiner WITTMANN	
<b>CATEGORY OF CITED DOCUMENTS</b> X : particularly relevant if taken alone Y : particularly relevant if combined with another document of the same category A : technological background O : non-written disclosure P : intermediate document		T : theory or principle underlying the invention E : earlier patent document, but published on, or after the filing date D : document cited in the application L : document cited for other reasons ..... & : member of the same patent family, corresponding document	