

~~ORIGINAL~~

## ABSTRACT

Disclosed herein is a water treatment system, including: a raw water storage tank; a TiO<sub>2</sub> supply unit introducing TiO<sub>2</sub> into the raw water storage tank; an LED-UV irradiation unit receiving raw water containing TiO<sub>2</sub> from the raw water storage tank, irradiating the raw water with LED-UV and then discharging the raw water, the LED-UV irradiation unit being provided therein with at least one LED-UV lamp; and a membrane receiving the raw water irradiated with LED-UV from the LED-UV irradiation unit and then recovering TiO<sub>2</sub> from the raw water.

WE claim that:

1. A water treatment system, comprising:  
a raw water storage tank;  
a TiO<sub>2</sub> supply unit introducing TiO<sub>2</sub> into the raw water storage tank;  
an LED-UV irradiation unit receiving raw water containing TiO<sub>2</sub> from the raw water storage tank, irradiating the raw water with LED-UV and then discharging the raw water, the LED-UV irradiation unit being provided therein with at least one LED-UV lamp; and  
a membrane receiving the raw water irradiated with LED-UV from the LED-UV irradiation unit and then recovering TiO<sub>2</sub> from the raw water.

2. The water treatment system as claimed in claim 1, wherein the LED-UV irradiation unit is provided with a water inlet at a lower portion thereof and a water outlet at an upper portion thereof such that raw water flows upward.

3. The water treatment system as claimed in claim 2, wherein the LED-UV irradiation unit has a rectangular parallelepiped shape, is provided with the water inlet at a lower corner of one side thereof and is provided with the water outlet at an upper corner of another side thereof facing the one side such that the water outlet is positioned diagonally opposite to the water inlet.

4. The water treatment system as claimed in claim 3, wherein the LED-UV irradiation unit having a rectangular parallelepiped shape is configured such that LED-UV lamps are disposed at regular intervals throughout at least one of six inner sides thereof.

5. The water treatment system as claimed in claim 4, wherein the LED-UV irradiation

unit having a rectangular parallelepiped shape is configured such that LED-UV lamps are disposed at regular intervals on four of six inner sides thereof.

6. The water treatment system as claimed in claim 1, wherein the LED-UV lamp is an LED-UVA lamp.

7. The water treatment system as claimed in claims 1, wherein the LED-UV irradiation unit is provided with an ultrasonic generator.

8. The water treatment system as claimed in claim 7, wherein the ultrasonic generator is disposed at a bottom of the LED-UV irradiation unit.

*Dated this 5<sup>th</sup> day of March 2012*

*U. dike*  
OF ANAND AND ANAND ADVOCATES  
ATTORNEY FOR THE APPLICANT

00320112  
05 MAR 2012

FIG. 1

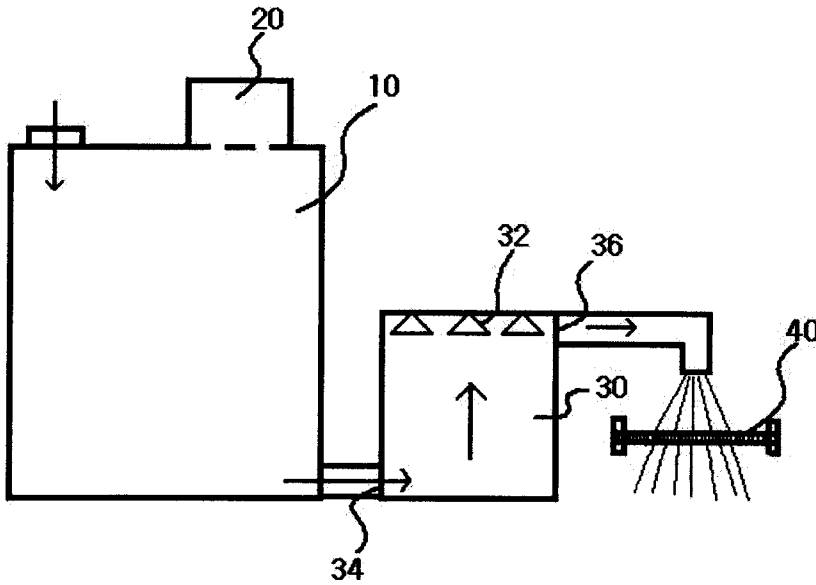
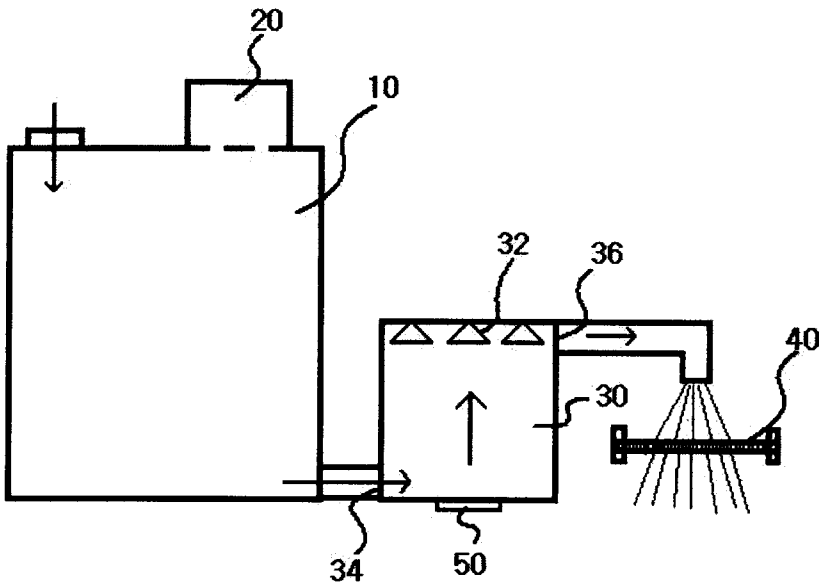

FIG. 2



*Shanker*

Archana Shanker  
of Anand and Anand Advocates  
Agent for the Applicant

5 Sheets  
Sheet 2  
06320112  
05 MAR 2012

FIG. 3

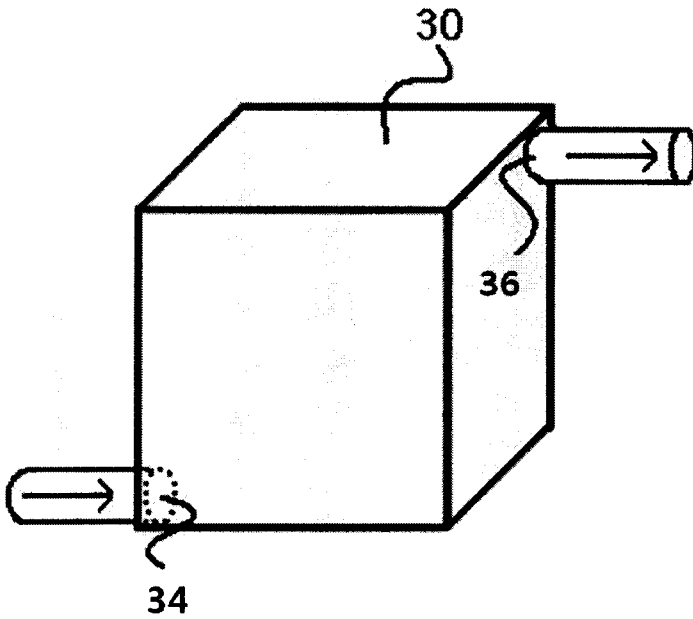
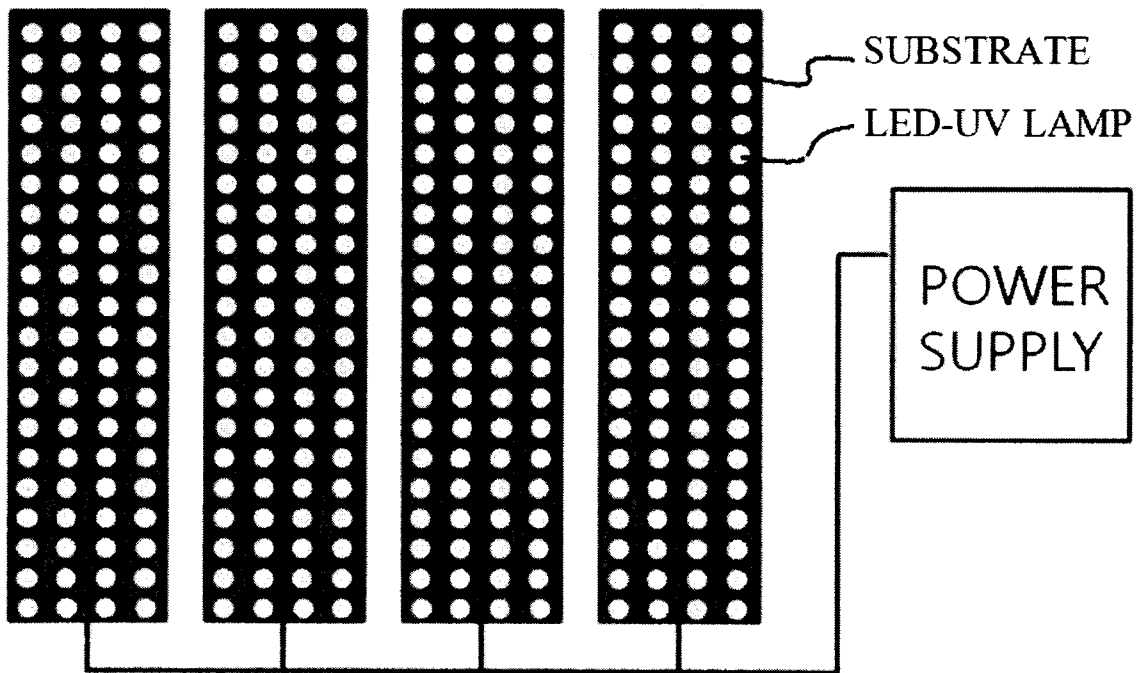

FIG. 4



*Shanker*  
Archana Shanker  
of Anand and Anand Advocates  
Agent for the Applicant

05 MAR 2012

FIG. 5

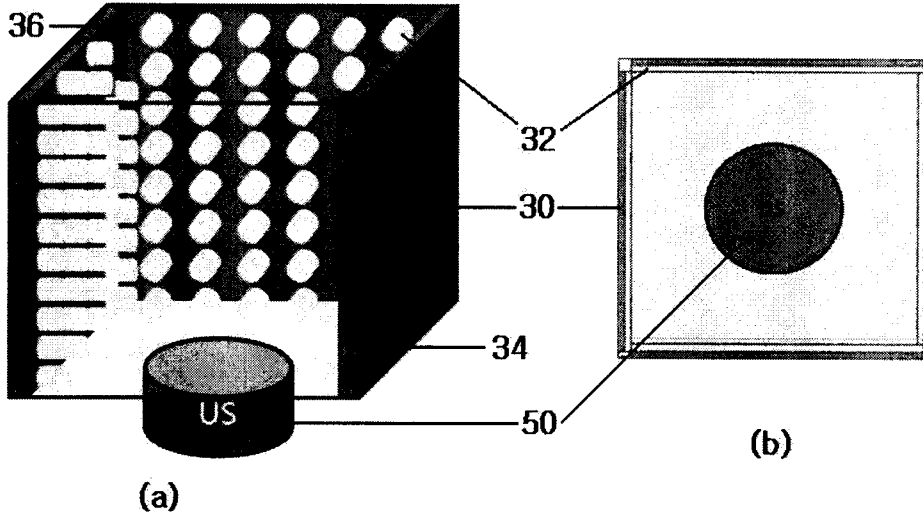
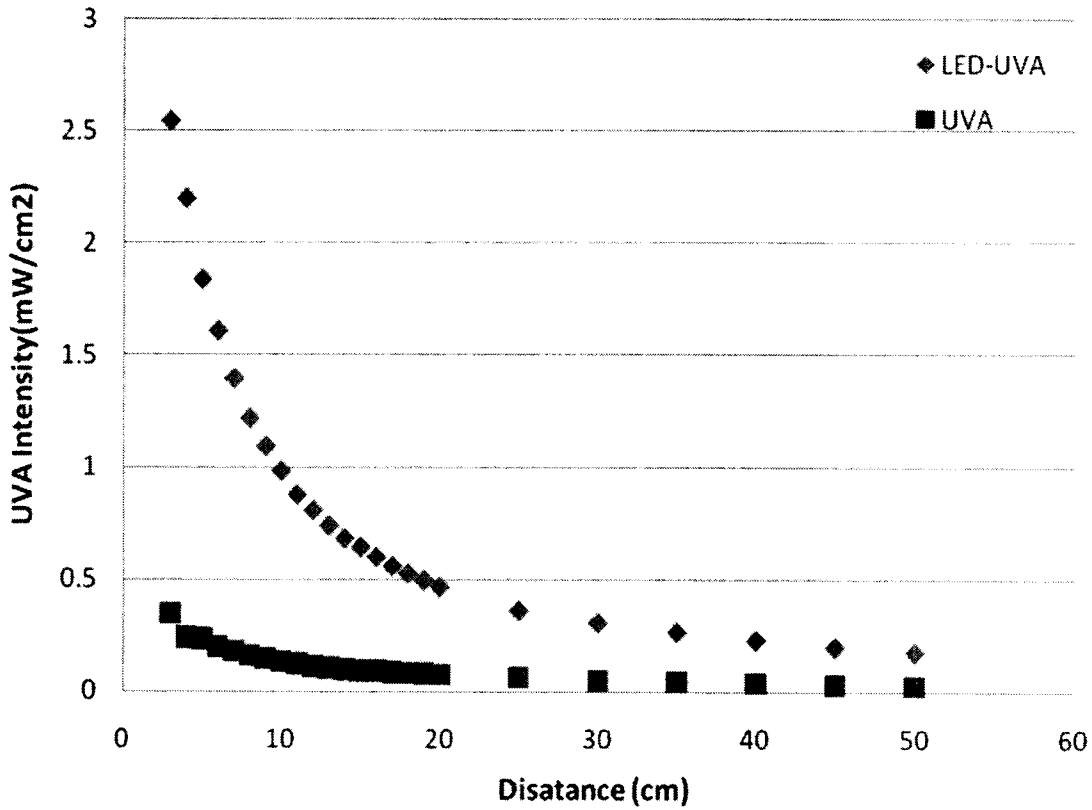

FIG. 6



*Shanker*  
Archana Shanker  
of Anand and Anand Advocates  
Agent for the Applicant

0632 DEL 12  
5  
Sheet 4

05 MAR 2012

FIG. 7

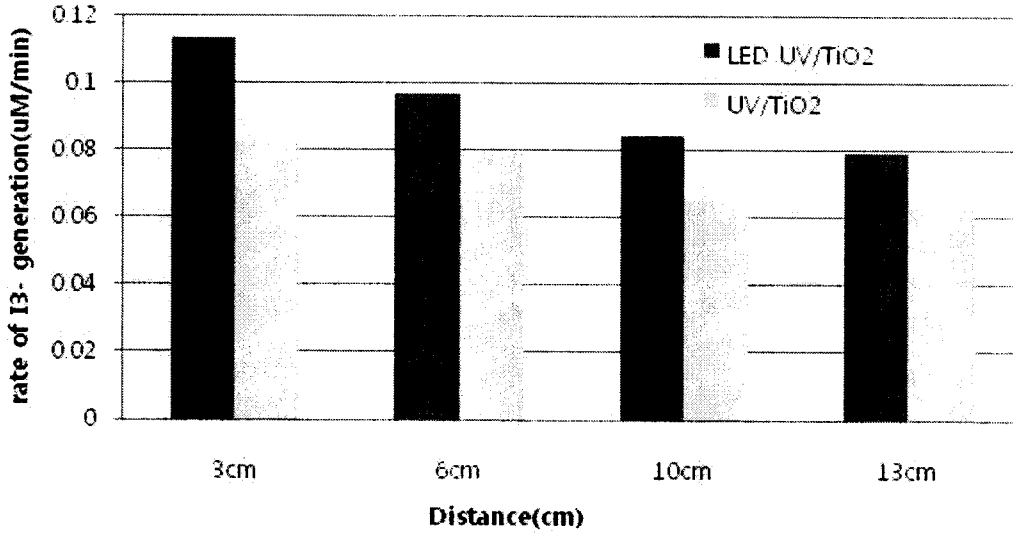
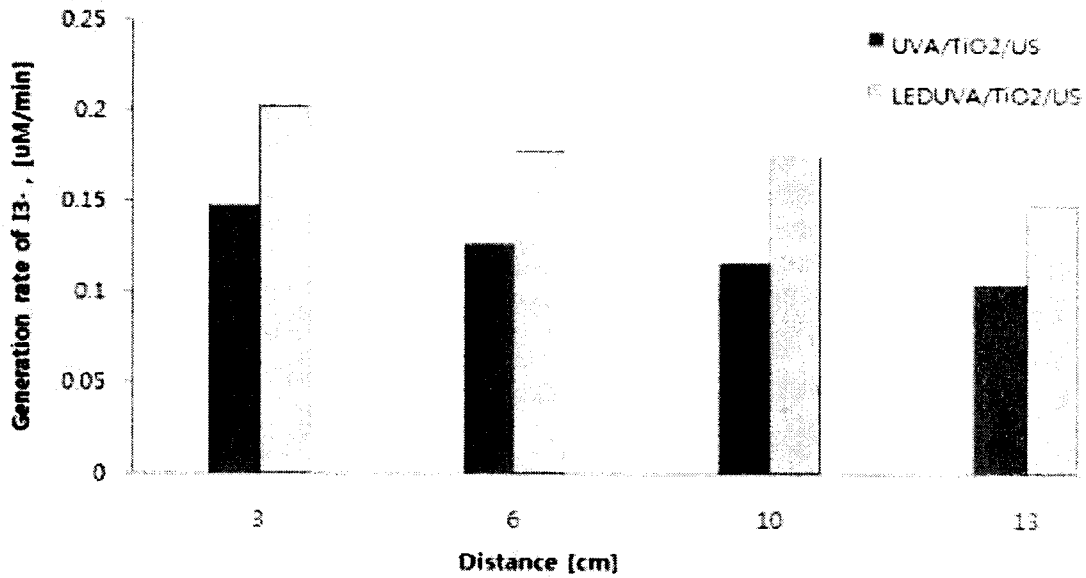

FIG. 8



*Shanker*  
Archana Shanker  
of Anand and Anand Advocates  
Agent for the Applicant

06320112  
05 MAR 2012

FIG. 9

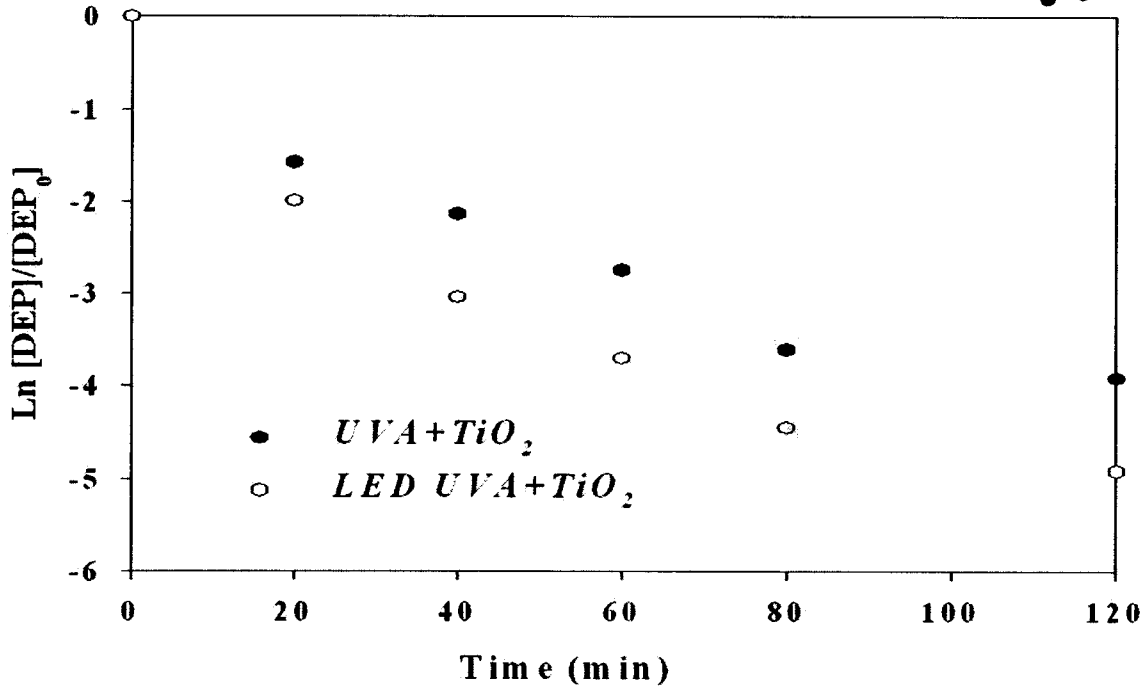
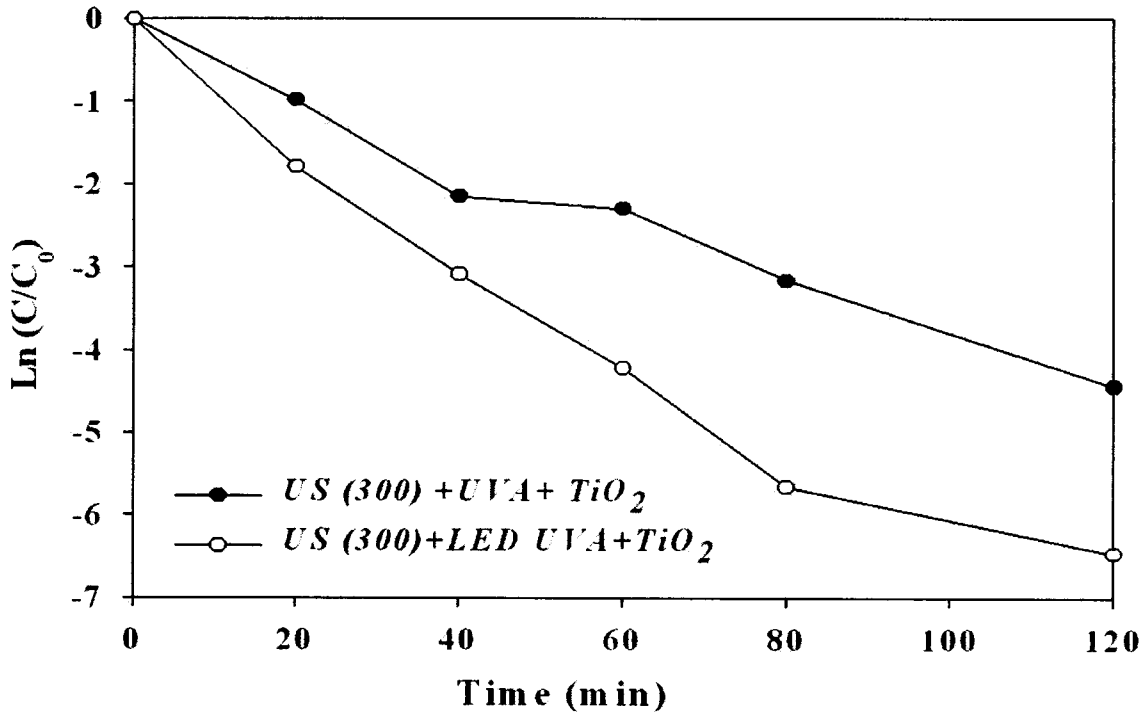

FIG. 10



*Archer*

Archana Shanker  
of Anand and Anand Advocates  
Agent for the Applicant

# WATER TREATMENT SYSTEM USING LED-UV LAMP AND PHOTOCATALYST

## BACKGROUND OF THE INVENTION

### 1. Technical Field

**[0001]** The present invention relates to a water treatment system using an LED-UV lamp and a photocatalyst.

### 2. Description of the Related Art

**[0002]** Currently, water treatment technologies using ultraviolet (UV) rays of various wavelength bands are being used commercially. The UV rays (100 nm ~ 380 nm) generally used in the field of water treatment may include UVC (100 nm ~ 280 nm) and UVA (320 nm ~ 380 nm), and they are used in combination with TiO<sub>2</sub> (photocatalyst) and/or ultrasound. For example, UV rays are used in the treatment of service water, intermediate water or sewage water by combining UVA or UVC with TiO<sub>2</sub>, combining UVA or UVC with ultrasound or combining UVA or UVC with and TiO<sub>2</sub> and ultrasound. Concretely, the above combinations are used to oxidize persistent organic pollutants from service water, intermediate water or sewage water or to sterilize and disinfect service water, intermediate water or sewage water.

**[0003]** However, most of currently-used UV lamps cause environmental pollution because they must include harmful chemicals such as mercury (Hg) and the like in order to produce a stable output and wavelength, and have a very short lifecycle because they produce low output. Therefore, it is not suitable for these UV lamps to be directly used in water treatment.

**[0004]** Moreover, disadvantages of conventional water treatment systems using the UV lamp include low water treatment efficiency due to problems with the efficiency the system itself and output of the UV lamp.

## SUMMARY OF THE INVENTION

[0005] Accordingly, the present invention has been devised to solve the above-mentioned problems, and an object of the present invention is to provide a water treatment system which can greatly improve water treatment efficiency by realizing an efficient water treatment mechanism using a persistent, stable and high-power LED-UV lamp together with a photocatalyst ( $\text{TiO}_2$ ).

[0006] In order to accomplish the above object, an aspect of the present invention provides a water treatment system, including: a raw water storage tank; a  $\text{TiO}_2$  supply unit introducing  $\text{TiO}_2$  into the raw water storage tank; an LED-UV irradiation unit receiving raw water containing  $\text{TiO}_2$  from the raw water storage tank, irradiating the raw water with LED-UV and then discharging the raw water, the LED-UV irradiation unit being provided therein with at least one LED-UV lamp; and a membrane receiving the raw water irradiated with LED-UV from the LED-UV irradiation unit and then recovering  $\text{TiO}_2$  from the raw water.

[0007] In the water treatment system, the LED-UV irradiation unit may be provided with a water inlet at a lower portion thereof and a water outlet at an upper portion thereof such that raw water flows upward.

[0008] Further, the LED-UV irradiation unit may have a rectangular parallelepiped shape, may be provided with the water inlet at a lower corner of one side thereof and may be provided with the water outlet at an upper corner of another side thereof facing the one side such that the water outlet is positioned diagonally opposite to the water inlet.

[0009] Further, the LED-UV irradiation unit having a rectangular parallelepiped shape may be configured such that LED-UV lamps are disposed at regular intervals throughout at least one of six inner sides thereof.

**[0010]** Further, the LED-UV irradiation unit having a rectangular parallelepiped shape may be configured such that LED-UV lamps are disposed at regular intervals on four of six inner sides there of.

**[0011]** Further, the LED-UV lamp may be an LED-UVA lamp.

**[0012]** Further, the LED-UV irradiation unit may be provided with an ultrasonic generator, and the ultrasonic generator may be disposed at a bottom of the LED-UV irradiation unit.

### BRIEF DESCRIPTION OF THE DRAWINGS

**[0013]** The above and other objects, features and advantages of the present invention will be more clearly understood from the following detailed description taken in conjunction with the accompanying drawings, in which:

**[0014]** FIG. 1 is a schematic view showing a water treatment system according to an embodiment of the present invention;

**[0015]** FIG. 2 is a schematic view showing a water treatment system including an ultrasonic generator according to another embodiment of the present invention;

**[0016]** FIG. 3 is a schematic view showing an LED-UV irradiation unit of the water treatment system of the present invention;

**[0017]** FIG. 4 is a schematic view showing plate-type LED-UV lamps used in the water treatment system of the present invention;

**[0018]** FIG. 5 shows schematic views of an LED-UV irradiation unit of the water treatment system of the present invention, wherein FIG. 5A is a perspective view and FIG. 5B is a plan view;

**[0019]** FIG. 6 is a graph showing the difference in light intensity between a UVA lamp and an LED-UVA lamp;

[0020] FIG. 7 is a graph showing the difference in hydroxyl radical generation rate between a conventional combination of UV/TiO<sub>2</sub> and a combination of LED-UV/TiO<sub>2</sub> of the present invention;

[0021] FIG. 8 is a graph showing the difference in hydroxyl radical generation rate between a conventional combination of US(ultrasound)/UVA/TiO<sub>2</sub> and a combination of US(ultrasound)/LED-UVA/TiO<sub>2</sub> of the present invention;

[0022] FIG. 9 is a graph comparing the capacity of treating a persistent pollutant (diethyl phthalate (DEP)) of a conventional combination of UV/TiO<sub>2</sub> with that of a combination of LED-UV/TiO<sub>2</sub> of the present invention; and

[0023] FIG. 10 is a graph comparing the capacity of treating a persistent pollutant (diethyl phthalate (DEP)) of a conventional combination of US(ultrasound)/UVA/TiO<sub>2</sub> with that of a combination of US(ultrasound)/LED-UVA/TiO<sub>2</sub> of the present invention.

#### DESCRIPTION OF THE PREFERRED EMBODIMENTS

[0024] Hereinafter, preferred embodiments of the present invention will be described in detail with reference to the attached drawings. Prior to the description of the present invention, when it is determined that the detailed description of the related art would obscure the gist of the present invention, the description thereof will be omitted.

[0025] FIG. 1 is a schematic view showing a water treatment system according to an embodiment of the present invention. That is, the water treatment system of the present invention includes: a raw water storage tank 10; a TiO<sub>2</sub> supply unit 20 introducing TiO<sub>2</sub> into the raw water storage tank 10; an LED-UV irradiation unit 30 receiving raw water containing TiO<sub>2</sub> from the raw water storage tank 10, irradiating the raw water with LED-UV and then discharging the raw water, the LED-UV irradiation unit 30 being provided therein with at least

one LED-UV lamp 32; and a membrane 40 receiving the water irradiated with LED-UV from the LED-UV irradiation unit 30 and then recovering TiO<sub>2</sub> from the raw water.

[0026] Since the water treatment system can treat all of service water, intermediate water and sewage water, the raw water storage tank 10 may store service water, intermediate water or sewage water.

[0027] The TiO<sub>2</sub> supply unit 20 serves to introduce a predetermined amount of TiO<sub>2</sub> powder into the raw water storage tank 10, and may be fabricated in the form of a commonly-known container.

[0028] In the water treatment system of the present invention, the raw water storage tank 10 may be provided therein with a stirrer in order to mix raw water with TiO<sub>2</sub> powder.

[0029] The LED-UV irradiation unit 30 functions to irradiate a mixed solution of raw water and TiO<sub>2</sub> powder with UV to decompose a very small amount of persistent organic pollutants included in the mixed solution and functions to sterilize and disinfect the mixed solution. The LED-UV irradiation unit 30 is provided therein with one or more LED-UV lamps 32.

[0030] The LED-UV lamp 32 used in the present invention emits light having a wavelength of 100 nm ~ 380 nm, and includes an LED-UVC lamp (100 nm ~ 280 nm) and an LED-UVA lamp (320 nm ~ 380 nm). Here, the use of the LED-UVA lamp is more preferable because it is used in combination with TiO<sub>2</sub> and can effectively decompose persistent organic pollutants.

[0031] The LED-UV lamp 32 has the following advantages: 1) it has high luminous efficiency and can obtain high power at low current, 2) its power consumption is low because it is small lightweight and has a long life, and 3) it is environment-friendly because it does not use mercury (Hg). Therefore, the water treatment system of the present invention, which uses the LED-UV lamp 32 as a light source, can stably and effectively treat a very small amount of persistent organic pollutants and can exhibit excellent sterilizing and disinfecting functions.

[0032] The membrane 40 serves to recover  $\text{TiO}_2$  from the mixed solution of raw water and  $\text{TiO}_2$ . The type of membrane 40 used is not subject to any limitation although it should be commonly known in the related field.

[0033] FIG. 2 is a schematic view showing a water treatment system further including an ultrasonic generator 50 according to another embodiment of the present invention.

[0034] The ultrasonic generator 50 serves to decompose persistent organic pollutants using ultrasonic waves and to exhibit sterilizing ability. The type of ultrasonic generator 50 used may be free of limitation although it should be commonly known in the related field.

[0035] The location at which the ultrasonic generator 50 is to be disposed can be freely determined depending on the form of the LED-UV irradiation unit 30 and the speed and direction of the flow of the raw water. However, as shown in FIG. 2, it is more effective for the ultrasonic generator 50 to be disposed at the bottom of the LED-UV irradiation unit 30.

[0036] As described above, when raw water is treated by combining the LED-UV lamp 32 and the photocatalyst ( $\text{TiO}_2$ ) with the ultrasonic generator 50, the function of decomposing persistent organic pollutants and the function of sterilizing and disinfecting raw water can be greatly improved.

[0037] FIG. 3 is a schematic view showing an LED-UV irradiation unit 30 of the water treatment system of the present invention.

[0038] As shown in FIG. 3, the LED-UV irradiation unit 30 may have a structure wherein a water inlet 34 is disposed at the lower portion thereof and a water outlet 36 is disposed at the upper portion thereof such that raw water flows upward. However, the structure of the LED-UV irradiation unit 30 is not limited thereto.

[0039] When the LED-UV irradiation unit 30 has such a structure, raw water is sufficiently exposed to UV while flowing upward, so that the persistent organic pollutants present in the raw water can be effectively, reliably and uniformly decomposed and raw water can be effectively

sterilized and disinfected. In particular, such a structure is efficient when continuously moving and treating raw water.

**[0040]** Further, as shown in FIG. 3, when the LED-UV irradiation unit 30 has a rectangular parallelepiped shape, is provided with a water inlet 34 at the lower corner of one side thereof and is provided with a water outlet 36 at the upper corner of another side thereof facing the one side thereof such that the water outlet 34 is positioned diagonally opposite to the water inlet, raw water flows upward so that raw water can be uniformly irradiated with UV rays by the LED-UV lamp 32, thereby more effectively decomposing persistent organic pollutants and sterilizing and disinfecting the raw water.

**[0041]** In the present invention, the LED-UV irradiation unit 30 having a rectangular parallelepiped shape may be configured such that LED-UV lamps are disposed at regular intervals throughout at least one of six inner sides thereof. In relation to this, FIG. 4 schematically shows a plate-type LED-UV lamp module used in the water treatment system of the present invention.

**[0042]** Further, FIG. 5 schematically shows an LED-UV irradiation unit 30 of the water treatment system of the present invention, wherein the LED-UV irradiation unit has a rectangular parallelepiped shape and is configured such that LED-UV lamps are disposed at regular intervals on four of six inner sides thereof. In FIG. 5, FIG. 5A is a perspective view in which the front and top sides thereof are transparent such that the inside thereof can be observed, and FIG. 5B is a plan view.

**[0043]** As such, when LED-UV lamps are disposed at regular intervals on four of six inner sides thereof, a sufficient amount of UV light can be effectively applied to the raw water to be treated.

**[0044]** In the water treatment system of the present invention, the number and location of LED-UV lamps can be freely determined depending on the form of the LED-UV irradiation unit 30 and the speed and direction of the flow of raw water.

**[0045]** A water treatment process using the water treatment system of the present invention, as shown in FIGS. 1 and 2, may include the steps of: introducing  $\text{TiO}_2$  into a raw water storage tank 10 from a  $\text{TiO}_2$  supply unit 20 and then mixing the  $\text{TiO}_2$  with raw water; supplying the raw water containing  $\text{TiO}_2$  from the raw water storage tank 10 to an LED-UV irradiation unit 30 to irradiate the raw water with LED-UV and then discharge the raw water irradiated with LED-UV; and passing the discharged raw water irradiated with LED-UV through a membrane 40 to recover the  $\text{TiO}_2$ . In this case, if the LED-UV irradiation unit 30 is provided with an ultrasonic generator 50, persistent organic pollutants can be more effectively decomposed and raw water can also be more effectively sterilized and disinfected because raw water is irradiated with LED-UV, and ultrasonic waves can be simultaneously applied to the raw water.

**[0046]** Hereinafter, the present invention will be described in more detail with reference to FIGS. 6 to 10. The data shown in FIGS. 6 to 10 were measured by a method commonly used in the related field.

**[0047]** FIG. 6 is a graph showing the difference in light intensity between a UVA lamp and an LED-UVA lamp. As shown in FIG. 6, it can be seen that the light intensity of an LED-UVA lamp used in the present invention is remarkably different from that of a conventional UVA lamp.

**[0048]** FIG. 7 is a graph showing the difference in hydroxyl radical generation rate between a conventional combination of UV/ $\text{TiO}_2$  and a combination of LED-UV/ $\text{TiO}_2$  of the present invention. As shown in FIG. 7, it can be seen that the hydroxyl radical generation rate of the combination of LED-UV/ $\text{TiO}_2$  of the present invention is remarkably different from that of a conventional combination of UV/ $\text{TiO}_2$ .

**[0049]** FIG. 8 is a graph showing the difference in hydroxyl radical generation rate between a conventional combination of US(ultrasound)/UVA/TiO<sub>2</sub> and a combination of US(ultrasound)/LED-UVA/TiO<sub>2</sub> of the present invention. As shown in FIG. 8, it can be seen that the hydroxyl radical generation rate of the combination of US(ultrasound)/LED-UVA/TiO<sub>2</sub> of the present invention is remarkably different from that of a conventional combination of US(ultrasound)/UVA/TiO<sub>2</sub>.

**[0050]** FIG. 9 is a graph comparing the capacity of treating a persistent pollutant (diethyl phthalate (DEP)) of a conventional combination of UV/TiO<sub>2</sub> with that of a combination of LED-UV/TiO<sub>2</sub> of the present invention. As shown in FIG. 9, it can be seen that the capacity of treating a persistent pollutant (diethyl phthalate (DEP)) of the combination of LED-UVA/TiO<sub>2</sub> of the present invention is remarkably different from that of a conventional combination of UVA/TiO<sub>2</sub>.

**[0051]** FIG. 10 is a graph comparing the capacity of treating a persistent pollutant (diethyl phthalate (DEP)) of a conventional combination of US(ultrasound)/UVA/TiO<sub>2</sub> with that of a combination of US(ultrasound)/LED-UVA/TiO<sub>2</sub> of the present invention. As shown in FIG. 10, it can be seen that the capacity of treating a persistent pollutant (diethyl phthalate (DEP)) of the combination of US(ultrasound)/LED-UVA/TiO<sub>2</sub> of the present invention is remarkably different from that of a conventional combination of US(ultrasound)/UVA/TiO<sub>2</sub>.

**[0052]** As described above, since the water treatment system of the present invention uses a persistent, stable and high-power LED-UV lamp together with a photocatalyst (TiO<sub>2</sub>), it can effectively treat persistent organic pollutants included in service water, intermediate water or sewage water and can efficiently sterilize and disinfect service water, intermediate water or sewage water.

**[0053]** Further, the improved water treatment system of the present invention can greatly increase water treatment efficiency because the operational mechanism of the LED-UV lamp and the photocatalyst (TiO<sub>2</sub>) can be improved.

[0054] Although the preferred embodiments of the present invention have been disclosed for illustrative purposes, those skilled in the art will appreciate that various modifications, additions and substitutions are possible, without departing from the scope and spirit of the invention as disclosed in the accompanying claims.