

(19) World Intellectual Property
Organization
International Bureau



(43) International Publication Date
8 January 2004 (08.01.2004)

PCT

(10) International Publication Number
WO 2004/002280 A1

(51) International Patent Classification⁷: A47J 37/12, 27/00

(21) International Application Number: PCT/EP2003/003532

(22) International Filing Date: 4 April 2003 (04.04.2003)

(25) Filing Language: English

(26) Publication Language: English

(30) Priority Data: MI2002 A 001431 28 June 2002 (28.06.2002) IT

(71) Applicant (for all designated States except US): DE' LONGHI S.p.A. [IT/IT]; Via L. Seitz, 47, I-31100 Treviso (IT).

(72) Inventor; and

(75) Inventor/Applicant (for US only): DE' LONGHI, Giuseppe [IT/IT]; Vicolo Rovero, 1, I-31100 Treviso (IT).

(74) Agent: RAPISARDI, Mariacristina; Ufficio Brevetti Rapisardi S.r.l., Via Serbelloni, 12, I-20122 Milano (DE).

(81) Designated States (national): AE, AG, AL, AM, AT, AU, AZ, BA, BB, BG, BR, BY, BZ, CA, CH, CN, CO, CR, CU, CZ, DE, DK, DM, DZ, EC, EE, ES, FI, GB, GD, GE, GH, GM, HR, HU, ID, IL, IN, IS, JP, KE, KG, KP, KR, KZ, LC, LK, LR, LS, LT, LU, LV, MA, MD, MG, MK, MN, MW, MX, MZ, NO, NZ, OM, PH, PL, PT, RO, RU, SC, SD, SE, SG, SK, SL, TJ, TM, TN, TR, TT, TZ, UA, UG, US, UZ, VC, VN, YU, ZA, ZM, ZW.

(84) Designated States (regional): ARIPO patent (GH, GM, KE, LS, MW, MZ, SD, SL, SZ, TZ, UG, ZM, ZW), Eurasian patent (AM, AZ, BY, KG, KZ, MD, RU, TJ, TM), European patent (AT, BE, BG, CH, CY, CZ, DE, DK, EE, ES, FI, FR, GB, GR, HU, IE, IT, LU, MC, NL, PT, RO, SE, SI, SK, TR), OAPI patent (BF, BJ, CF, CG, CI, CM, GA, GN, GQ, GW, ML, MR, NE, SN, TD, TG).

Declaration under Rule 4.17:
— of inventorship (Rule 4.17(iv)) for US only

Published:
— with international search report

For two-letter codes and other abbreviations, refer to the "Guidance Notes on Codes and Abbreviations" appearing at the beginning of each regular issue of the PCT Gazette.

(54) Title: COOKING DEVICE AND PROCEDURE

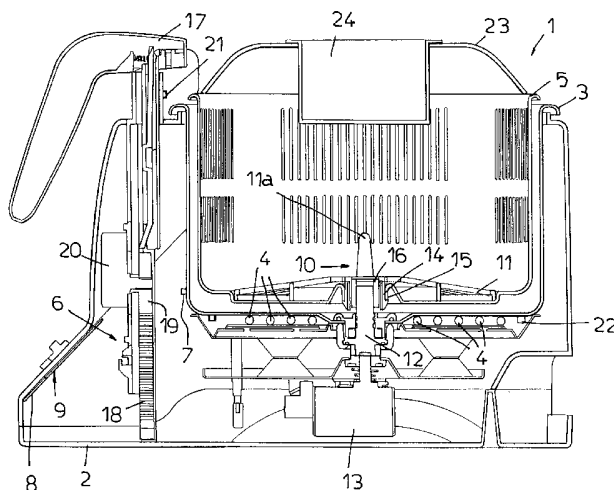

(57) Abstract: The cooking device (1) comprises a body (2) which carries a bowl (3) with electrical heating means (4) and containing a basket (5) for food. The basket is connected to drive means (6) suitable for moving it between a position inside the bowl and a position at least partially outside of it. The device also comprises a first sensor (7) of the temperature of at least a portion of the bowl and a timer (8) connected to means (9) for controlling the drive means, for moving the basket in relation to signals that the control means receives from the temperature sensor and from the timer. In the procedure for cooking through the indicated device the heating means heats the water contained in the bowl taking it up to a predetermined temperature, at which point the first sensor detects that such a predetermined temperature has been reached and the basket is lowered and, at the same time, the timer is started for a preset time period, at the end of which the control means deactivates the heating means and commands the removal of the basket from the bowl.

WO 2004/002280 A1

COOKING DEVICE AND PROCEDURE

DESCRIPTION

The present invention refers to a cooking device and procedure.

In particular, hereafter reference shall be made to a device and a procedure for cooking pasta. Nevertheless, it is clear that they are also equally applicable for cooking other dishes such as, for example, Chinese-style rice, Italian-style risotto, etc.

Currently, the cooking of pasta is carried out through pans containing water which is usually made to boil through hob plates.

When the water boils the pasta is thrown into the pan and is left to cook for the necessary time.

Then, when cooking is complete, the pasta is drained through a drainer.

The devices of the conventional type have numerous drawbacks which can be summed up as the following.

The use of hob plates, often gas-fired, can be dangerous in particular when the pan is not watched over. An unforeseen bubbling over of water or froth from the pan could, indeed, put out the flame without interrupting the gas supply. The consequences in this case are easy to imagine.

Moreover, conventional devices need to be watched over continuously also because the active presence of an operator to throw in the pasta, to stir, to drain, etc., is necessary. Otherwise the food obtained is of a very poor quality.

Moreover, conventional devices require substantial experience to achieve good results in particular with reference how much the pasta is cooked. In many cases, indeed, precisely due to lack of experience, the pasta is cooked for too long with very poor results.

The technical task proposed of the present invention is, therefore, that of realising a cooking device and procedure which allow the aforementioned technical drawbacks of the prior art to be eliminated.

In this technical task a purpose of the invention is that of realising a cooking device which can function, in complete safety and ensuring the quality of the food cooked, without the presence of a user being necessary to continuously watch over and/or actively operate, for example stirring the food.

Another purpose of the invention is that of realising a device which is very safe and which, in particular, does not require the use of flammable gas.

The last but not least purpose of the invention is that of realising a device and a procedure which allow various types of food, in particular pasta, to be cooked in an optimal manner, also when the user has very limited cooking experience and even allows people without any experience at all to cook pasta and other food in an optimal manner.

The technical task, as well as these and other purposes, according to the present invention are achieved through a cooking device characterised in that it comprises a body which carries a bowl with electrical heating means and

containing a basket for containing food to be cooked, said basket being connected to drive means suitable for moving it between a position inside said bowl and a position at least partially outside of it, said device also comprising a first sensor of the temperature of at least a portion of said bowl and a timer connected to means for controlling said drive means, for moving said basket, in relation to signals that said control means receives from said temperature sensor and from said timer.

Suitably, the present finding also refers to a procedure for cooking through a device according to claim 1, characterised in that said heating means heats the water contained in the bowl taking it up to a predetermined temperature, at which point the first sensor detects that such a predetermined temperature has been reached and the basket is plunged into said water and, at the same time, the timer is started for a preset time period, at the end of which the control means deactivates the heating means and command the removal of the basket from said bowl.

Other characteristics of the present invention are, moreover, defined in the other claims.

Further characteristics and advantages of the invention shall become clearer from the description of a preferred but not exclusive embodiment of the cooking device and procedure according to the present finding, where the device is illustrating for indicating and not limiting purposes in the attached drawings, in which:

- figure 1 shows a cross-section of the device according to the present finding;
- figure 2 shows a partial section perspective view of the device according to the finding;
- figure 3 shows a detail of a different embodiment of the device;
- figure 4 shows a diagram of the device with control and drive means of the electromechanical type;
- figure 5 shows a circuit diagram of the device of figure 4;
- figure 6 shows a partial section view of a device equipped with an anti-rotation element for the pasta; and
- figure 7 shows a drive group.

With reference to the aforementioned figures, a cooking device is shown wholly indicated with reference numeral 1.

The device 1 comprises a body 2 which carries a bowl 3 having electrical heating means 4, for example consisting of shielded resistances, and containing a basket 5 for containing the food to be cooked.

The basket 5 is connected to drive means 6 suitable for moving it between a position inside said bowl and a position at least partially outside of it.

The device also comprises a first sensor 7 of the temperature of at least a portion of said bowl and a timer 8 connected to control means 9 (for example realised through a circuit board or else electromechanically) which, in turn, are connected to drive means 6 so as to move the basket 5 in relation to the signals which the control means 9 receives from the

temperature sensor 7 and from the timer 8, between the position inside the bowl 3 and the position at least partially outside of it.

Moreover, the device 1 comprises means 10 for stirring the food contained inside the basket 5 which is also connected to the control means 9.

In particular, the mixing means 10 comprises an element 11 rotatably connected to the basket 5 and removably connected to a drive group 12 which protrudes from the body 2 and is connected to a first motor 13.

Preferably, the rotatable element 11 comprises a disc, for example with a grid, (figure 1) substantially conical, from which protruding paddles 11a extend, having a widened central portion 14 rotatably connected in a through-seat 15 realised on the base of the basket 5.

Moreover, the widened central portion 14 defines a seat 16 suitable for receiving a portion of the drive group 12.

Figure 3 shows a different embodiment, in which the rotatable element 11 comprises a shaft from which the protruding paddle 11a extend.

The rotatable element 11 has the central portion 14 raised and rotatably connected in the through-seat 15 realised on the base of the basket 5.

The raised central portion 14 defines the seat 16 suitable for receiving a portion of the drive group 12.

The drive means comprises a support for the basket 17 which has a rack 18 operatively connected to a pinion 19 capable of

being actuated through a second motor 20, which is connected to the control means 9.

Suitably, the device 1 comprises at least one second sensor 21 suitable for detecting the position of the basket 5, for example consisting of a microswitch, a photocell or a magnetic sensor.

Moreover, the bowl 3 is removably connected to the body 2, i.e. in a way so that it can be taken apart and put back together again. In this way the bowl 3 can be removed for easy emptying of the water and cleaning.

Advantageously, to ensure safety, the device 1 comprises at least a third sensor 22 of the presence of the bowl 3 and a closing cover 23 applied above the basket 5 to allow the basket 5 itself to be moved without hindrance from the cover 23.

Advantageously, moreover, the cover 23 comprises at least one anti-foaming hatch (not shown for the sake of simplicity in the attached figures), free to oscillate from an open position to a closed position and vice-versa when the pressure inside the bowl 3 exceeds a predetermined value.

In this way, during the cooking of pasta, when the typical cooking foam forms inside the bowl 3, the internal pressure tends to open the hatch allowing a large intake of air inside the bowl 3 and, therefore, the reduction in foam.

Moreover, through the hatch 20 it is also possible to control the progression of the cooking of the pasta or else to pick out a piece of pasta to taste it and check how much it is

cooked, in the case in which one prefers pasta which is more or less cooked with respect to the optimal cooking instructions.

The cover 23 has a central hole in which a container 24 is housed suspended in the basket 5.

For example, the container 23 is used for the sauce, so as to heat or cook the sauce at the same time as the pasta.

The device is also equipped with a control panel (not represented for the sake of simplicity), which allows the cooking times to be programmed and detected even in the timespan of 24 hours. In this way it is possible to freely set the moment when one wishes to have the pasta drained. Suitably, moreover, when the device is not used the timer shows the time of day and functions as a clock.

The operation of the cooking device 1 according to the invention is clear from that which has been described and illustrated and, in particular, is substantially the following.

Hereafter, reference shall be made to the case in which the cooking of pasta is carried out immediately after the programming of the device and then the case in which the pasta is cooked at a predetermined time of day, for example the device is programmed and prepared in the morning to obtain the cooked and drained pasta at lunch.

In the first case (i.e. pasta cooked immediately after the programming of the device), beforehand the bowl 3 is filled with salted water, the pasta is inserted in the basket 5

which is in raised position and the cooking time of the pasta is set.

Then the device is switched on and the water is heated so that it boils.

In practice, the boiling temperature is recognised when the sensor 7 detects, after switching on, a stable temperature below a predetermined temperature.

When the sensor 7 detects that the water is substantially close to boiling, the control means 9 commands the lowering of the basket 5 and the starting of the timer 8. At the same time a sound is also emitted through a buzzer (not represented).

After a certain time from the lowering of the basket into the bowl 3 the control means 9 actuates the motor 13 of the stirring means 10, to prevent the pasta from sticking.

Advantageously, moreover, the control means 9 cyclically activates and deactivates the heating means 4 and stirring means 10, so as to partialise the power transmitted to the water and to obtain a less turbulent boiling movement of the water producing less foam obtaining a better stirring.

Suitably, a minute before the end of the set time, the buzzer is again activated by the control means 9 and emits an other sound.

The cooking proceeds until the timer 8, when it detects the end of the set time, sends a signal to the control means 9 which commands the deactivation of the heating means 4 and the lifting of the basket 5.

In the second case (i.e. pasta cooked at a predetermined time of day) the control means 9 activates the heating means 3 at the set time, the control means checks (through the temperature sensor 7) the increase in temperature of the water (which depends upon the amount of water to be heated) and, in the case in which it is too quick, it interrupts the power supply to the electric means and calculates the waiting time before starting to heat again.

Then the whole thing is carried out as described previously, with the heating means which takes the water to a temperature close to boiling and the basket which is lowered into the water for the cooking of the pasta and, when cooking is complete, it is removed.

Advantageously, the present invention also refers to a procedure for cooking through a device of the type described previously.

The sensor 7 also functions as a safety element since when it detects a temperature higher than a safety temperature it interrupts the operation of the device.

According to the procedure the heating means 4 heats the water contained in the bowl 3 up to a predetermined temperature, for example close to boiling.

When the first sensor 7 detects that such a predetermined temperature has been reached the basket 5 is lowered into the water and, at the same time, the timer 8 is started for a preset period of time.

When the timer 8 reaches the end of such a preset period of

time the control means 9 deactivates the heating means 4 and commands the removal of the basket 5 from the bowl 3.

Advantageously, moreover, after a predetermined period of time from the lowering of the basket 5 into the bowl 3 the stirring means 10 is actuated. Preferably, moreover, the heating means 4 and/or stirring means 0 are activated discontinuously, so as to partialise the power, to reduce the turbulence of the water and to reduce the production of foam. Figures 4 and 5 show a different embodiment of the device 1 in which the control means 9 and the drive means 6 are of the electromechanical type.

With particular reference to figure 4, an electromechanical timer 25 connected to the device 1 has a toothed portion 26 and two portions equipped with cams, a first cam 27 which protrudes and a second cam 28 which is grooved.

The toothed portion 26 is associated with an arm 29 which has a toothed end kept in contact with the toothed portion 26 by a counter spring 30, and another end connected to a microswitch 31.

The tothing of the portion 26 is of the type which allows the teeth of the portion 26 and of the arm 29 to be locked when the timer tends to turn in one direction (i.e. it prevents the rotation of the timer in one direction) whereas it allows the sliding of the teeth one on top of the other in the opposite direction (therefore, for example, when the arm 29 and the toothed portion 26 are connected to each other the timer can rotate only in anti-clockwise direction, as

indicated by the arrow F).

The microswitch 31, moreover, is arranged on the path of the rack 18, so that the rack 18, during its motion downwards (to lower the basket 5), actuates the microswitch 31 which interrupts the power supply to the motor 20 and locks the basket 5 inside the bowl 3 sunk in the water.

The cam 27 is suitable for actuating the microswitch 32 (the microswitch 32 is closed when it is connected to the cam) which commands the start of the power supply to the motor 20 and, then, the lifting of the basket 5.

In practice, when the cam 27 is connected to the microswitch 32 it closes the electric circuit of the device whereas when the cam 27 is not connected to the microswitch 32 (for example when the timer is set to cook pasta) the electric circuit of the device is open.

The grooved cam 28 is associated with a pin 33 connected to a further microswitch 34.

The microswitch 34 is suitable for being connected to a protruding portion 35 of the rack 18 so that, when the pin 33 is inserted in the grooved cam 28 and the basket is in lifted position, the microswitch 34 is connected to the portion 35 of the rack 18 and the electric circuit of the device is open, whereas when the pin 33 is in contact with the cylindrical drum outside of the grooved cam 28, the microswitch 34 is not connected to the portion 35 and the electric circuit of the device 1 is closed.

The operation of the device 1 in this embodiment happens as

substantially indicated hereafter, with particular reference to figure 5 which schematically shows the electric circuit of the device.

In rest position, i.e. when the device 1 is not used, the configuration of the switches is the one shown with a full line (microswitch 31 closed, microswitch 32 closed, microswitch 34 open, sensor 7 open, the sensor 7 being of the THS type and being suitable for operating as a switch controlled by the temperature detected).

When the timer 25 is set the power supply to the heating means 3 and to the motor for the shaft 13 begins. The microswitch 32 is closed, the microswitch 31 remains closed (with the arm 29 which keeps the timer 25 locked) and the microswitch 34 is closed (since it is taken away from the portion 35), (microswitch 31 closed, microswitch 32 open, microswitch 34 closed, sensor 7 open).

The temperature increases until, when around boiling temperature is reached, the sensor 7 closes and allows the power supply to the motor 20 (through the microswitch 31 and 34) which lowers the basket into the bowl 3 (microswitch 31 closed, microswitch 32 open, microswitch 34 closed, sensor 7 closed).

During the downwards motion the rack 18 meets the microswitch 31, opens it (interrupting the flow of current) and stopping the basket 5 inside the bowl 3 (microswitch 31 open, microswitch 32 open, microswitch 34 closed, sensor 7 closed).

At the same time the rack 18 displaces the arm 29 moving it

away from the toothed portion 26 and allowing the start of the counting by the timer of the cooking time of the pasta. During the counting of the timer 25, the cams 27 and 28 rotate. When the timer has almost stopped counting the cam 27 closes the microswitch 32 and actuates the motor 20 which lifts the basket 5 removing it from the bowl 3. At the same time the pin 33 starts to lower down since it starts to insert inside the grooved cam 28 (microswitch 31 open, microswitch 32 closed, microswitch 34 closed, sensor 7 closed).

When during lifting the portion 35 opens the microswitch 34, the power supply to the motor 20 is interrupted and the basket 5 remains suspended on the bowl 3 out of the water (the microswitches go back into the starting configuration - microswitch 31 closed, microswitch 32 closed, microswitch 34 open).

Figures 3 and 6 show another embodiment of the device according to the finding equipped with anti-rotation means 36 for the pasta.

In particular, the anti-rotation means 36 comprises a fixed anti-rotation element connected to a fixed part of the device 1 and inserted inside the basket 5 and the bowl 3.

Preferably, such a fixed anti-rotation element 36 has an end placed between the trajectories of the paddles 11a and has a portion connected to the top of the support 17, consisting of a handle.

In the attached figures as an example the space taken up by

spaghetti is also represented, wholly indicated with reference numeral 37.

Advantageously, when the stirring means 10 (such as the shaft) rotates, the anti-rotation means prevents the pasta from rotating together with it and ensures excellent stirring.

Figure 7 shows a drive group 12 comprising a pin guide 38 slidably connected to the basket 5 and having an inner hole 39 which is at least partially faceted and a threaded lower portion 40. A pin 41 is inserted in the hole 39 (without the possibility of rotating). The pin 41 has a faceted portion 42 and two throats 43 which house seals (not shown). The lower part 44 of the pin is widened and is coated in teflon to promote sliding. The pin 41, at the bottom, has a perimetric edge 45 and a blade 46 suitable for connecting to a connection element 47 of the motor 13.

The pin 41 is connected to the pin guide 38 (and thus to the basket 5) by the nut 48. The connection element 47 comprises a disc 49 which has four protruding pins 50 (for example with a triangular section) and a square hole 51 in which the drive shaft 52 (also square) of the motor 13 is slidably inserted. Moreover, a spring 53, which allows gaps to be closed, is placed between the case of the motor 13 and the disc 49.

When the basket 5 is lowered the blade 46 inserts between the pins 50 and ensures the connection and the actuation of the stirring means 10. If the blade 46 locks above the pins 50 the rotation of the disc 49 and the push of the spring 53

take the drive group 12 back to correct configuration.

In practice, it has been noted how the cooking device and procedure according to the invention are particularly advantageous because they allow the cooking of pasta in particular, but also other dishes, without the need for it to be watched over continuously and always ensuring optimal results.

For example, indeed, the device according to the present finding also allows rice, custard, mousses, soups, polenta, etc. to be cooked. Moreover, advantageously, the device can also be used for steam-cooking food.

The cooking device and procedure thus conceived are susceptible to numerous modifications and variants, all covered by the inventive concept. Moreover, all of the details can be replaced with technically equivalent elements. In practice, the materials used, as well as the sizes, can be whatever according to the requirements and the state of the art.

CLAIMS

1. Cooking device characterised in that it comprises a body which carries a bowl with electrical heating means and containing a basket for containing food to be cooked, said basket being connected to drive means suitable for moving it between a position inside said bowl and a position at least partially outside of it, said device also comprising a first sensor of the temperature of at least a portion of said bowl and a timer connected to means for controlling said drive means, for moving said basket, in relation to signals that said control means receives from said temperature sensor and from said timer.

2. Cooking device according to claim 1, characterised in that it comprises means for stirring said food contained inside said basket and connected to said control means.

3. Cooking device according to one or more of the previous claims, characterised in that said stirring means comprises an element rotatably connected to said basket and removably connected to a drive group which protrudes from said body and is connected to a first motor.

4. Cooking device according to one or more of the previous claims, characterised in that said rotatable element comprises a substantially conical disc, with a widened central portion rotatably connected in a through-seat realised on the base of said basket, said widened central portion defining a seat suitable for receiving said drive group.

5. Cooking device according to one or more of the previous claims, characterised in that said rotatable element comprises a shaft which has a central portion rotatably connected in a through-seat realised on the base of said basket, said central portion defining a seat suitable for receiving a portion of said drive group.

6. Cooking device according to one or more of the previous claims, characterised in that said drive means comprises a support for said basket which has a rack operatively connected to a pinion which can be actuated through a second motor, said second motor being connected to said control means.

7. Cooking device according to one or more of the previous claims, characterised in that it comprises at least one second sensor suitable for detecting the position of said basket.

8. Cooking device according to one or more of the previous claims, characterised in that said bowl is removably connected to said body.

9. Cooking device according to one or more of the previous claims, characterised in that it comprises at least one third sensor of the presence of said bowl.

10. Cooking device according to one or more of the previous claims, characterised in that it comprises a closing cover applied on said basket.

11. Cooking device according to one or more of the previous claims, characterised in that said cover comprises at least

one anti-foam door, free to oscillate from an open position to a closed position and vice-versa when the pressure inside said bowl exceeds a predetermined value.

12. Cooking device according to one or more of the previous claims, characterised in that said cover has a hole in which a container is housed suspended in said basket.

13. Cooking device according to one or more of the previous claims, characterised in that said control means and said drive means are of the electromechanical type.

14. Cooking device according to one or more of the previous claims, characterised in that said control means comprises a timer operatively connected to one or more microswitches.

15. Cooking device according to one or more of the previous claims, characterised in that it comprises anti-rotation means for the pasta.

16. Cooking device according to one or more of the previous claims, characterised in that said anti-rotation means comprises a fixed anti-rotation element connected to a fixed part of the device and inserted into said basket and said bowl.

17. Cooking device according to one or more of the previous claims, characterised in that said fixed anti-rotation element has an end placed between trajectories of said paddles.

18. Cooking device according to one or more of the previous claims, characterised in that said fixed element has a portion connected above said support.

19. Cooking device according to one or more of the previous claims, characterised in that said drive group comprises a pin guide slidably connected to said basket and with a hole and a threaded lower portion, in said hole being inserted a pin with a blade suitable for connecting to a connection element of said first motor.

20. Cooking device according to one or more of the previous claims, characterised in that said connection element comprises a disc which has a plurality of protruding pins and a hole in which a drive shaft of said first motor is slidably inserted, where a spring, which allows gaps to be closed, is placed between the casing of said first motor and said disc.

21. Procedure for cooking through a device according to claim 1, characterised in that said heating means heats the water contained in the bowl taking it up to a predetermined temperature, at which point the first sensor detects that such a predetermined temperature has been reached and the basket is plunged into said water and, at the same time, the timer is started for a preset time period, at the end of which the control means deactivates the heating means and commands the removal of the basket from said bowl.

22. Procedure according to the previous claim, characterised in that after a predetermined period of time from the lowering of the basket into the bowl the stirring means is actuated.

23. Procedure according to one or more of claims 19 and thereafter, characterised in that said heating means is

activated discontinuously, so as to partialise the power, to decrease the turbulence of the water and to reduce the production of foam.

24. Procedure according to one or more of claims 19 and thereafter, characterised in that when the pasta is cooked at a predetermined time of day, said control means activates said heating means at a set time and checks the increase in temperature of the water and, in the case in which it is too fast, it interrupts the power supply to the electrical heating means and calculates the waiting time before starting to heat again.

25. Cooking device and procedure as described, represented in the attached figures and claimed.

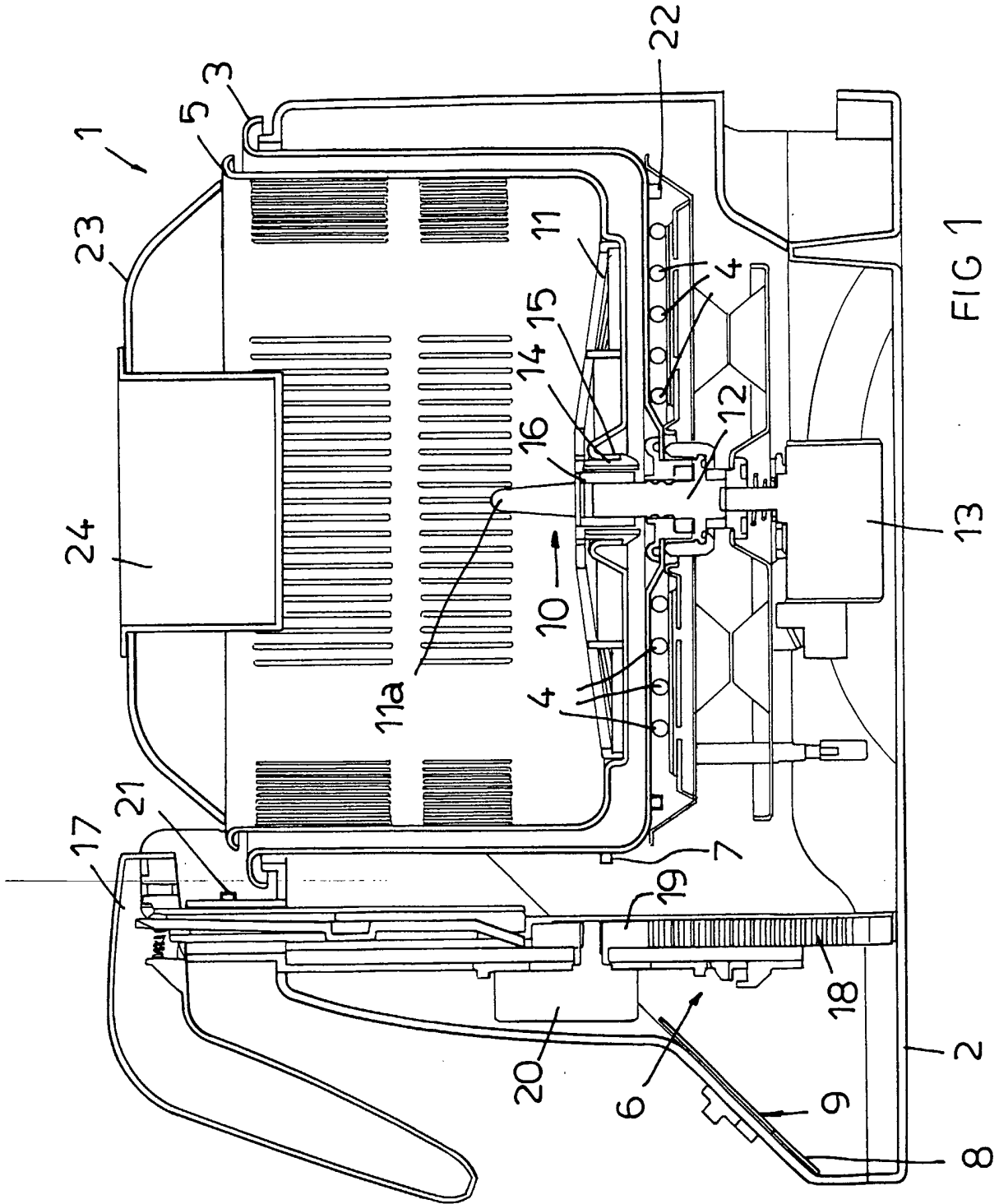

FIG 1

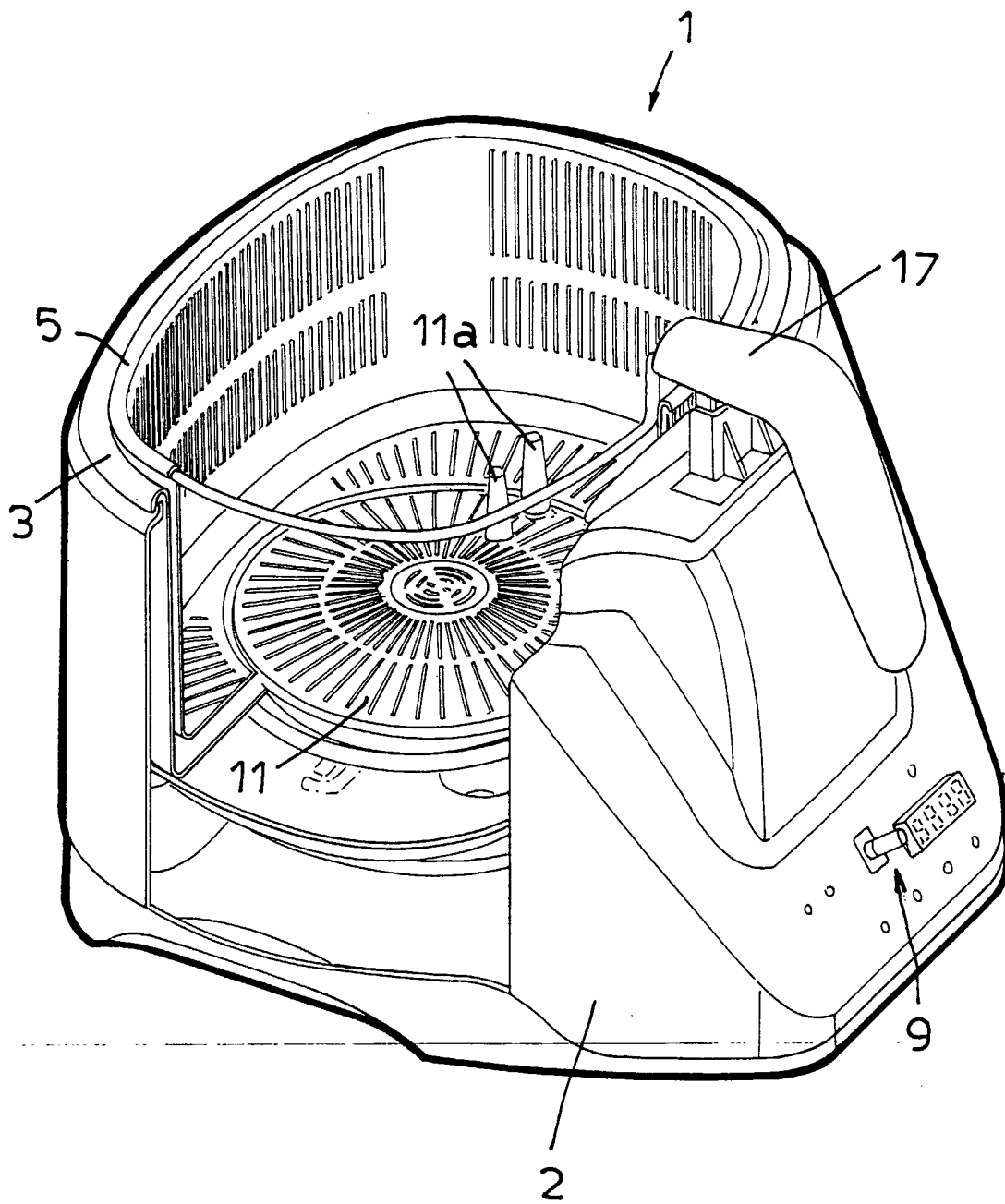

FIG 2

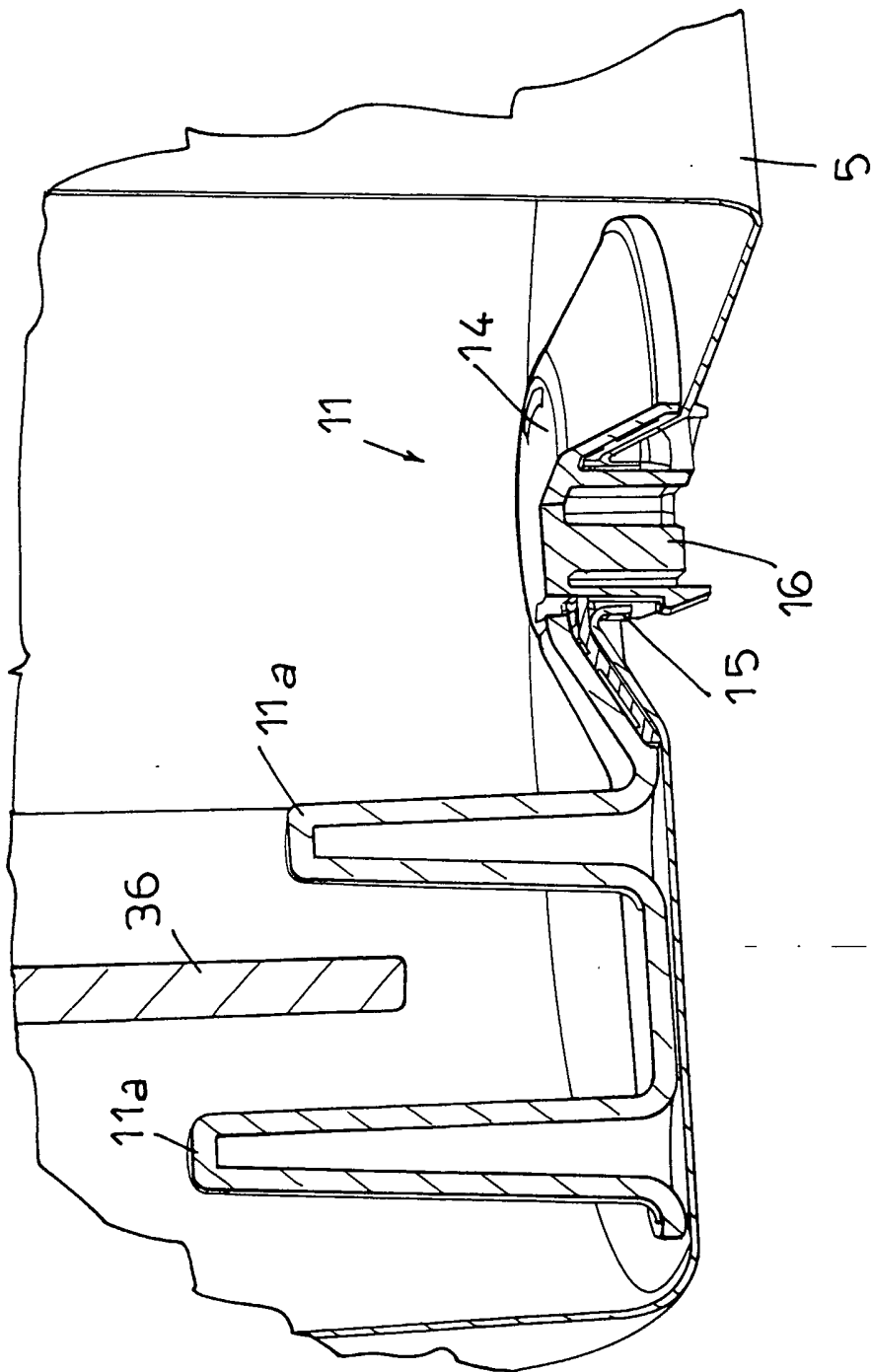

FIG 3

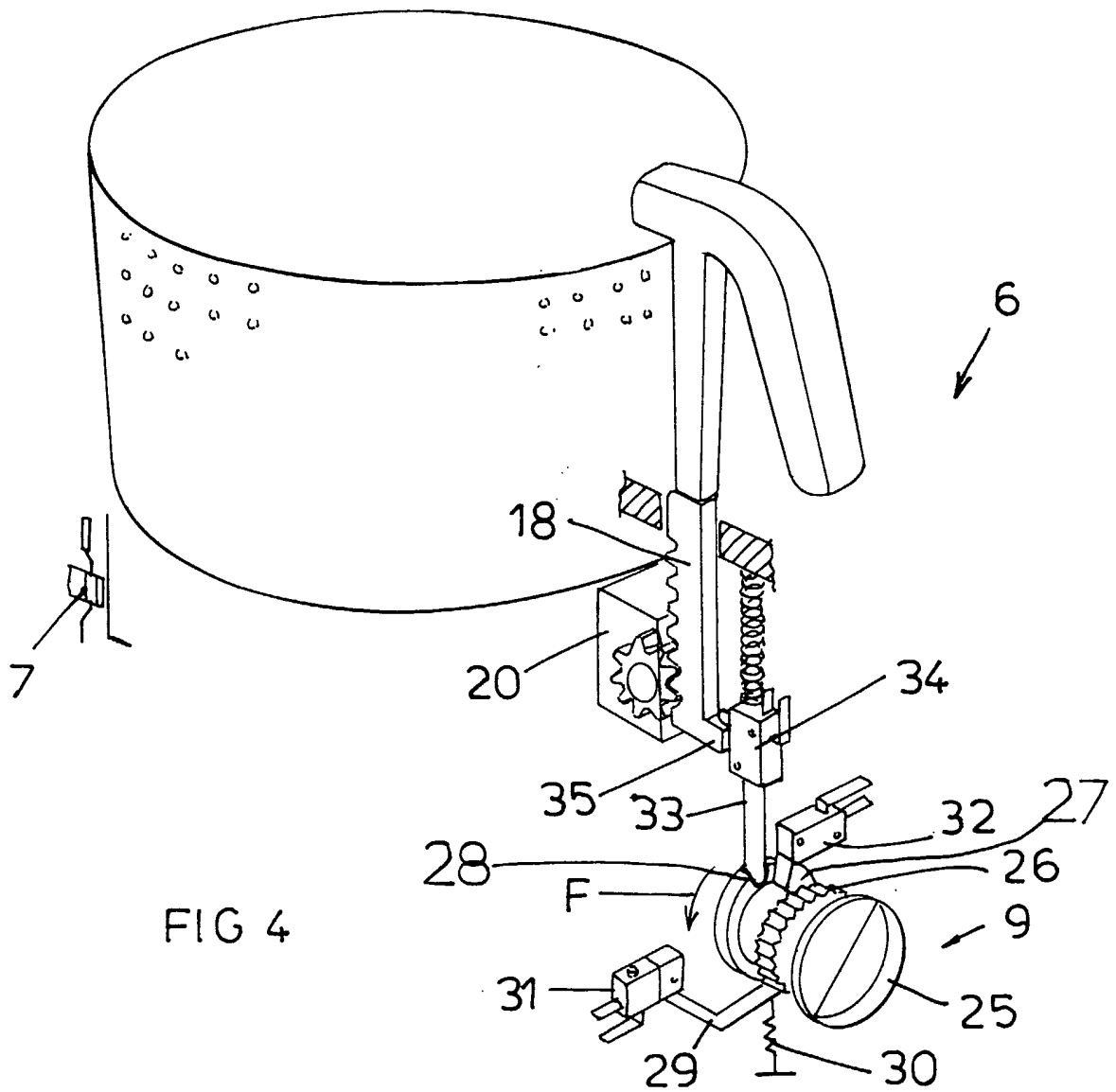

FIG 4

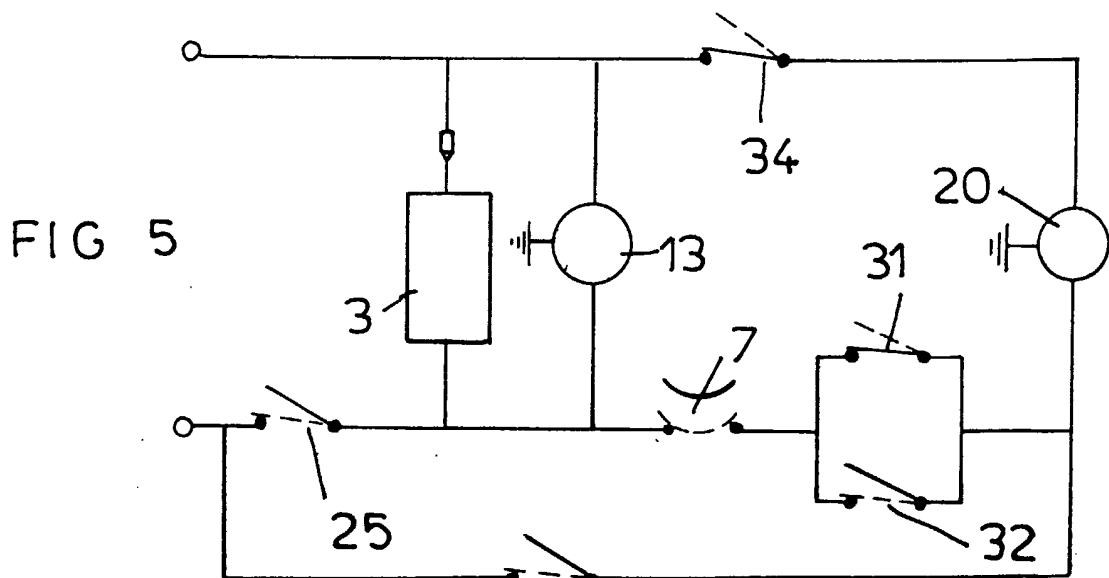

FIG 5

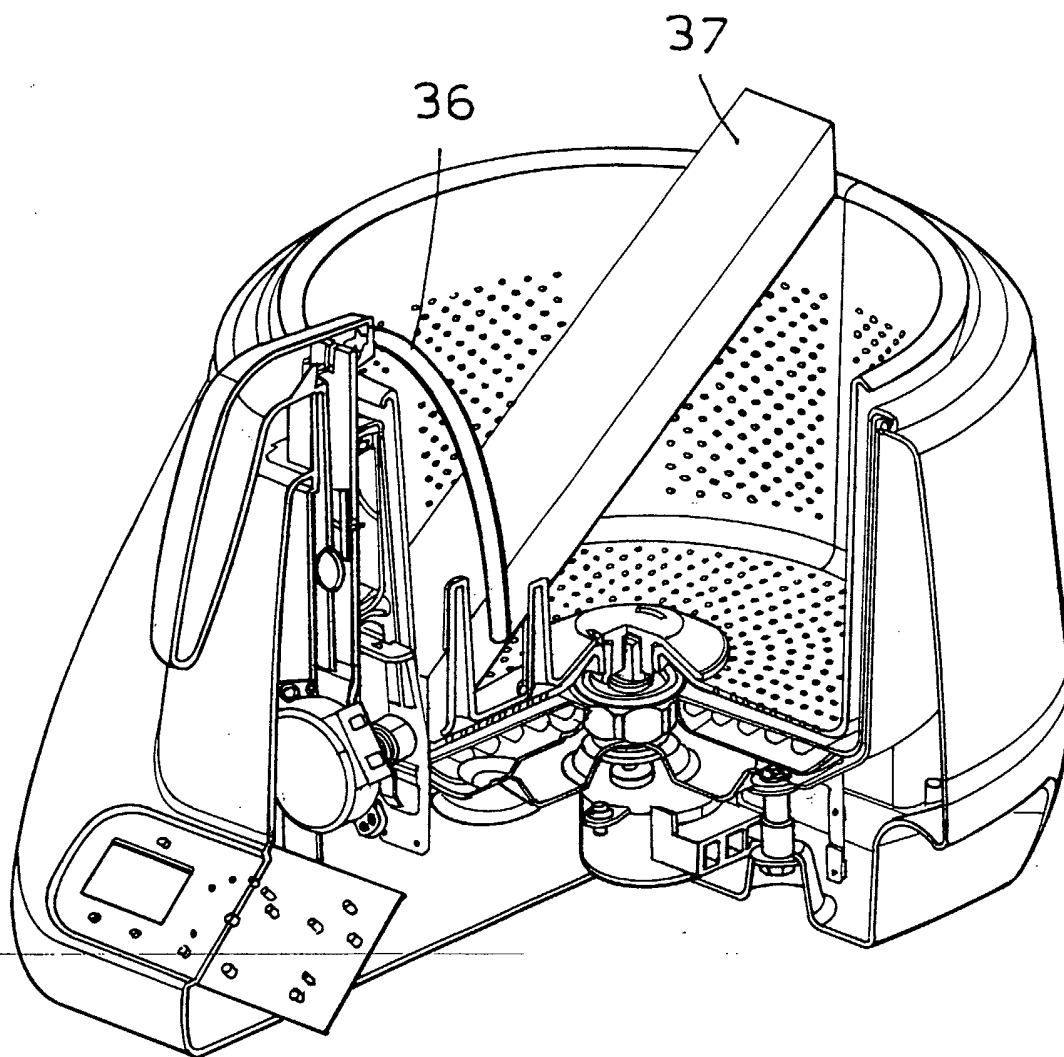

FIG 6

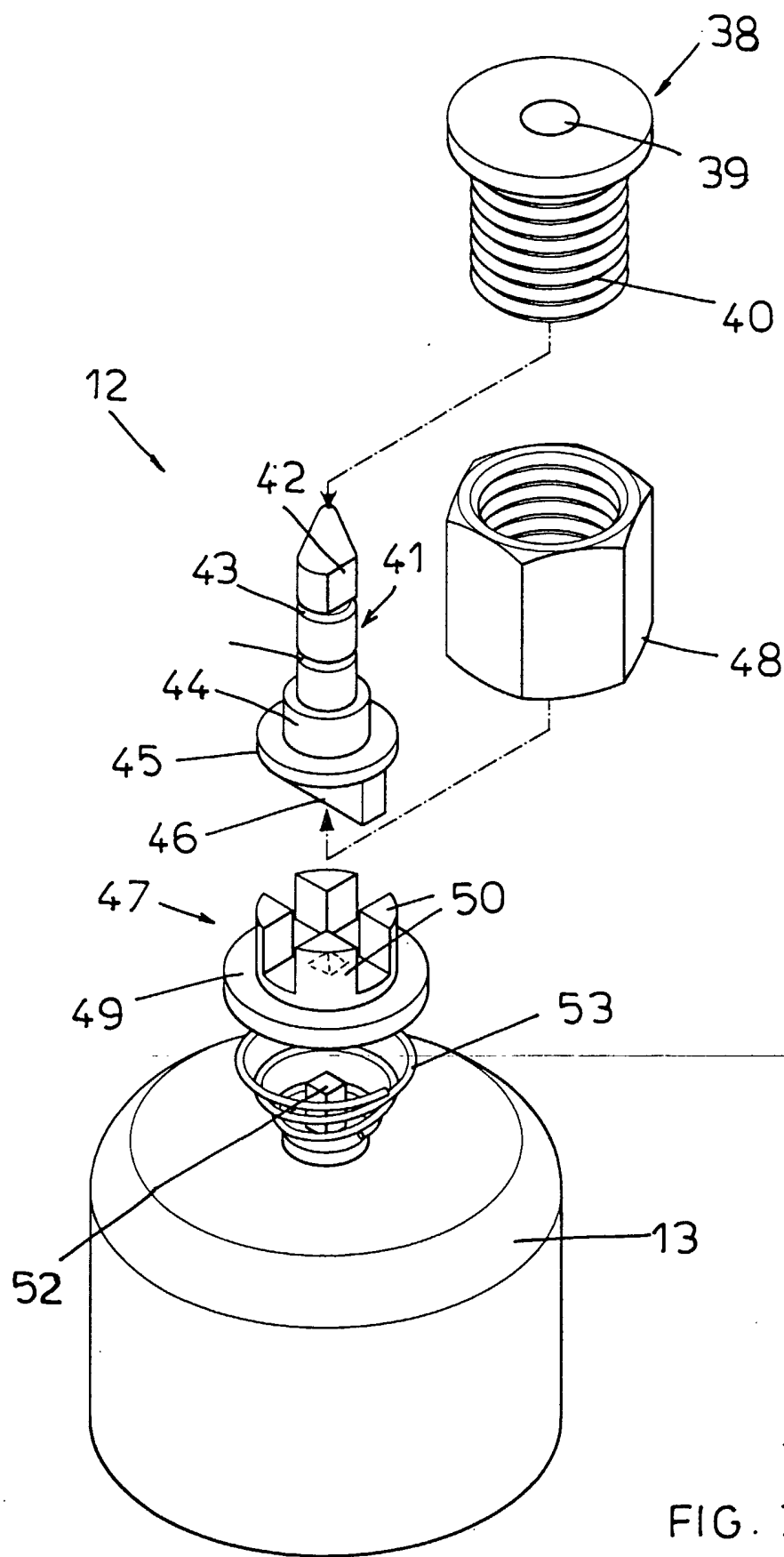

FIG. 7

INTERNATIONAL SEARCH REPORT

International Application No

PCT/EP 03/03532

A. CLASSIFICATION OF SUBJECT MATTER
 IPC 7 A47J37/12 A47J27/00

According to International Patent Classification (IPC) or to both national classification and IPC

B. FIELDS SEARCHED

Minimum documentation searched (classification system followed by classification symbols)

IPC 7 A47J

Documentation searched other than minimum documentation to the extent that such documents are included in the fields searched

Electronic data base consulted during the international search (name of data base and, where practical, search terms used)

EPO-Internal, WPI Data, PAJ

C. DOCUMENTS CONSIDERED TO BE RELEVANT

Category °	Citation of document, with indication, where appropriate, of the relevant passages	Relevant to claim No.
X	US 4 951 558 A (FIGLIUZZI VINCENT D) 28 August 1990 (1990-08-28) column 2, line 16 - line 50 column 3, line 47 -column 7, line 16; figures 1-4,10-12	1,8,13, 14,21,25
Y	---	7,9
A	---	22
Y	EP 0 716 827 A (FRYMASTER CORP) 19 June 1996 (1996-06-19) abstract	7,9
X	US 5 590 583 A (HARRISON ROBERT G) 7 January 1997 (1997-01-07) column 2, line 66 -column 5, line 32; figures 1,6,7	1,8,10, 11,13, 14,25

	-/--	

Further documents are listed in the continuation of box C.

Patent family members are listed in annex.

° Special categories of cited documents :

- *A* document defining the general state of the art which is not considered to be of particular relevance
- *E* earlier document but published on or after the international filing date
- *L* document which may throw doubts on priority claim(s) or which is cited to establish the publication date of another citation or other special reason (as specified)
- *O* document referring to an oral disclosure, use, exhibition or other means
- *P* document published prior to the international filing date but later than the priority date claimed

- *T* later document published after the international filing date or priority date and not in conflict with the application but cited to understand the principle or theory underlying the invention
- *X* document of particular relevance; the claimed invention cannot be considered novel or cannot be considered to involve an inventive step when the document is taken alone
- *Y* document of particular relevance; the claimed invention cannot be considered to involve an inventive step when the document is combined with one or more other such documents, such combination being obvious to a person skilled in the art.
- *&* document member of the same patent family

Date of the actual completion of the international search

11 August 2003

Date of mailing of the international search report

20/08/2003

Name and mailing address of the ISA

European Patent Office, P.B. 5818 Patentlaan 2
 NL - 2280 HV Rijswijk
 Tel. (+31-70) 340-2040, Tx. 31 651 epo nl,
 Fax: (+31-70) 340-3016

Authorized officer

Lehe, J

INTERNATIONAL SEARCH REPORT

International Application No
PCT/EP 03/03532

C.(Continuation) DOCUMENTS CONSIDERED TO BE RELEVANT		
Category °	Citation of document, with indication, where appropriate, of the relevant passages	Relevant to claim No.
A	US 5 010 805 A (FERRARA DANIEL A) 30 April 1991 (1991-04-30) column 2, line 37 -column 4, line 55; figures 1,7,8 ---	2
A	US 5 611 265 A (RONCI FERNANDO F ET AL) 18 March 1997 (1997-03-18) column 4, line 15 -column 6, line 17; figures 1,4-8 -----	1

INTERNATIONAL SEARCH REPORT

Information on patent family members

International Application No

PCT/EP 03/03532

Patent document cited in search report		Publication date	Patent family member(s)	Publication date
US 4951558	A	28-08-1990	NONE	
EP 0716827	A	19-06-1996	US 5544567 A AT 172365 T CA 2163046 A1 DE 69505488 D1 DE 69505488 T2 EP 0716827 A1	13-08-1996 15-11-1998 17-06-1996 26-11-1998 11-03-1999 19-06-1996
US 5590583	A	07-01-1997	US 5526734 A US 5588352 A AU 4088596 A CA 2144213 A1 DE 19600937 A1 GB 2296849 A ,B	18-06-1996 31-12-1996 25-07-1996 14-07-1996 18-07-1996 17-07-1996
US 5010805	A	30-04-1991	NONE	
US 5611265	A	18-03-1997	NONE	