

⑫ **EUROPEAN PATENT SPECIFICATION**

- ④⑤ Date of publication of patent specification: **20.04.88** ⑤① Int. Cl.⁴: **B 65 B 17/02**
②① Application number: **85300222.8**
②② Date of filing: **11.01.85**

⑤④ **Applicator device for applying carrier cartons to grouped articles.**

- | | |
|---|---|
| <p>③⑩ Priority: 12.01.84 GB 8400748</p> <p>④③ Date of publication of application:
07.08.85 Bulletin 85/32</p> <p>④⑤ Publication of the grant of the patent:
20.04.88 Bulletin 88/16</p> <p>④④ Designated Contracting States:
BE DE FR GB IT LU NL</p> <p>⑤① References cited:
GB-A-1 427 510
US-A-3 492 778</p> | <p>⑦③ Proprietor: THE MEAD CORPORATION
Mead World Headquarters Courthouse Plaza
Northeast
Dayton Ohio 45463 (US)</p> <p>⑦② Inventor: Heynen, Johan
Klain Molenbeek 15
Bergen op Zoom (NL)</p> <p>⑦④ Representative: Hepworth, John Malcolm
J.M. Hepworth & Co. 36 Regent Place
Rugby Warwickshire CV21 2PN (GB)</p> |
|---|---|

EP 0 150 944 B1

Note: Within nine months from the publication of the mention of the grant of the European patent, any person may give notice to the European Patent Office of opposition to the European patent granted. Notice of opposition shall be filed in a written reasoned statement. It shall not be deemed to have been filed until the opposition fee has been paid. (Art. 99(1) European patent convention).

Description

This invention relates to an applicator device for simultaneously applying a plurality of so-called top-gripping type of carriers onto a number of articles arranged in a group. The invention is particularly suitable for applying top gripping carriers to bottles which are accommodated in a crate so that several multi-bottle packages are formed whereafter individual packages may be grasped and removed from the crate. The applicator device which comprises a reciprocal head is, but need not be, adapted to receive known top gripping carriers.

A known applicator for applying a top gripping type of paperboard carrier onto grouped bottles is disclosed in GB—A—1 427 510 in which arresting means are provided for engagement with a carrier within a locating zone of the applicator. The arresting means automatically engage and hold the carrier during application of the carrier on the bottles to be secured together and then automatically release the carrier.

The present invention utilises natural resilience of the paperboard carrier, which tends to return the carrier to its non-erected condition, to hold the carrier against an arresting lip in the applicator from which it is released during loading by being displaced by the bottle necks introduced into the carrier.

The invention provides an applicator device for applying at least one paperboard article carrier to a group of articles such as bottles which device comprises a base plate formed to provide a locating zone for each article carrier, each locating zone being adapted to receive an erected article carrier having apertured top and bottom walls interconnected by spaced side walls to form a generally tubular structure, said base plate having a plurality of spaced apertures formed in each of said locating zones for registry with like spaced apertures formed in the top and base walls of said carrier and arresting means carried by said base plate in each of said locating zones for engagement with the carrier adjacent one of the carrier side walls (known from GB—A—1427510), characterised in that a side wall of each locating zone of the applicator has a downwardly and outwardly inclined face which terminates remote from said base plate in an inwardly directed lip providing said arresting means so that the natural resilience of said carrier, which tends to return the carrier into its non-erected condition, cause the base wall of the carrier to be arrested by the arresting lip and the loading action of the articles into the carrier displaces the carrier longitudinally of the applicator into a more upright position, thereby releasing the carrier from the arresting lip.

An applicator device embodying the invention will now be described, by way of example, with reference to the accompanying drawings, in which:—

Figure 1 is a perspective view of an applicator head shown in operative position;

Figure 2 is a partial side view of the applicator head in which a top-gripping type bottle carrier is shown loaded into one of the locating zones of the applicator head; and

Figure 3 is a partial side view of the applicator head in which bottles are shown inserted in the bottle carrier.

Referring to the drawings, the applicator head 10 comprises a base plate 12 from one surface 12a of which a series of spaced transverse walls depend. The series of walls include a first end wall 14 which has its outermost face flush with one end of the base plate 12; a first intermediate wall 16 spaced from end wall 14; a second intermediate wall 18 spaced from intermediate wall 16; and a second end wall 20 spaced from intermediate wall 18 and which has its outermost face flush with the opposite end of the base plate. A longitudinal rib 22 extends centrally along surface 12a of the base plate and divides each of the transverse walls into two similar sections. The transverse walls and the longitudinal rib together define a number of carrier locating zones Z1—Z6. Thus, each locating zone is defined by a neighbouring pair of transverse walls and the longitudinal rib.

In each locating zone, the base plate is formed with four circular bottle-neck receiving apertures, e.g. apertures a₁—a₄ in zone Z₃, the spacing of which is chosen so as to be in registry with aligned bottle-neck receiving apertures formed in the top and base walls of a suitably sized carton when positioned for loading in that locating zone.

By way of example, the carton 'c' shown schematically in end view in locating zone Z₁ in FIGURE 2 comprises substantially parallel top and bottom walls 24, 26 respectively, interconnected by spaced side walls 28, 30 respectively, and central upstanding partition panel 32, thereby forming a generally tubular structure. Top wall 24 and bottom wall 26 are each formed with four bottle neck receiving apertures 'A' located in registry.

Referring now more specifically to the applicator head construction, the first transverse end wall 14 has a downwardly and outwardly inclined inner face 34 which terminates remote from surface 12a of base plate 12 in an inwardly directed arresting lip 34a. The inner face 34 also is formed with arcuate downwardly divergent recesses 36, 38 respectively, spaced for alignment with neighbouring bottle neck receiving apertures formed in the bottom panel of an adjacent bottle carrier. The arcuate recesses each provide clearance for receiving a portion of the periphery of a bottle neck when the bottle neck is inserted into an article carrier located in the locating zone.

Thus, end wall 14 provides one transverse end of locating zones Z₁ and Z₄ the opposite end of which is provided by face 40 of the first intermediate wall 16. Face 40 also is formed with arcuate recesses 42 and 44, respectively, which are similar to recesses 36 and 38 but which are spaced for alignment with the opposite bottle neck receiving apertures of the same adjacent bottle carrier 'C'. The opposite face 46 of the first

intermediate wall 16 is of similar construction and includes arcuate recesses 48 and 50. However, face 46 terminates remote from surface 12a of base plate 12 in an arresting lip 46a for locating zones Z₂ and Z₅. The second intermediate wall 18 is of similar construction to intermediate wall 16 described above and therefore provides an arresting lip for locating zones Z₃ and Z₆.

The second transverse end wall 20 also includes a downwardly and outwardly inclined inner face 52 but does not carry an arresting lip. Arcuate bottle neck clearance recesses 54, 56 are formed in the inner face 52 similar to those described in relation to end wall 14.

The applicator head is mounted for vertical reciprocal movement in a carton applicator machine which is adapted to receive a loaded crate of bottles beneath applicator head when in its raised position. At the beginning of a loading cycle flat carriers are withdrawn from a hopper, erected and correctly loaded into the locating zones of the applicator head by suitable loading means. Each locating zone e.g. Zone Z₁ (see FIGURE 2) receives an erected carrier 'c' such that the natural resilience of the paperboard carrier which tends to return the carrier into its flat (non-erected) condition causes the base wall 26 of the carrier (adjacent side wall 30) to be held arrested under the arresting lip 34a. Bottle carriers located in the other locating zones are similarly held in position and when the applicator head is fully loaded in which one bottle carrier is present in each locating zone, the applicator head is ready to execute an applicator stroke in relation to a crate of bottles therebelow. Thus, the applicator head is then moved downwards so that the bottle necks of bottles 'B' are received in the bottle neck receiving apertures of the carriers and the caps of the bottles pass into base plate apertures 'A'. During this action and with reference to carrier 'C' in locating zone Z, portions of each bottle neck pass along clearance recesses 36, 38 and 42, 44 and the loading action of the bottles into the carrier displaces the carriers longitudinally in the applicator head into a more upright position thereby releasing the carrier from the arresting lip. The side walls of the carrier are disposed in a substantially vertical position. Thereafter, the applicator head is raised again for reloading, leaving each of the carriers secured to the tops of a group of bottles 'B'.

Claims

1. An applicator device (10) for applying at least one paperboard article carrier (c) to a group of articles such as bottles (B) which device comprises a base plate (12) formed to provide a locating zone (Z) for each article carrier, each locating zone being adapted to receive an erected article carrier having apertured top and bottom walls interconnected by space side walls to form a generally tubular structure, said base plate (12) having a plurality of spaced apertures (a) formed in each of said locating zones (Z) for registry with

like spaced apertures (A) formed in the top and base walls of said carrier and arresting means (34a) carried by said base plate (12) in each of said locating zones (Z) for engagement with the carrier adjacent one of the carrier side walls characterised in that a transverse wall (14, 16, 18) of each locating zone (Z) of the applicator has downwardly and outwardly inclined face (34) which terminates remote from said base plate (12) in an inwardly directed lip (34a) providing said arresting means so that the natural resilience of said carrier, which tends to return the carrier into its non-erected condition, causes the base wall (26) of the carrier to be arrested by the arresting lip (34a) and the loading action of the articles (B) into the carrier displaces the carrier longitudinally of the applicator into a more upright position, thereby releasing the carrier from the arresting lip.

2. An applicator device according to claim 1, further characterised in that said base plate includes a plurality of spaced transverse walls (14, 16, 18, 20) depending from one surface (12a) of the plate and defining in part said locating zones and in that said arresting lip is provided on a free edge of some of said walls remote from said one surface so that each lip interferes with the space defining a locating zone.

3. An applicator device according to claim 2, further characterised in that said transverse walls comprise a first end wall (14) at one end of the base plate, a first intermediate wall (16) spaced from said end wall, a second intermediate wall (18) spaced from said first intermediate wall, and a second end wall (20) at the opposite end of the base plate spaced from said second intermediate wall, each of said first end walls and said first and second intermediate walls having an arresting lip extending in a direction which faces towards said second end wall.

4. An applicator device according to claim 3, further characterised in that a longitudinal rib (22) extends from said one end of the base plate to said opposite end of the base plate and divides each of said transverse walls into two similar parts, each of said locating zones being provided by the space between an opposed pair of said transverse wall parts and a portion of said longitudinal rib.

5. An applicator device according to claim 4, further characterised in that the side surface of each transverse wall part providing a boundary of a locating zone is formed with a recess (36, 38) aligned with each bottle neck receiving aperture (a) formed in the plate in that locating zone, said recess being divergent towards said one surface (12a) of the base plate and providing clearance for receiving a portion of the periphery of a bottle neck when the bottle neck is inserted into an article carrier located in the locating zone.

Patentansprüche

1. Anbringvorrichtung (10) zum Anbringen von mindestens einem Warenträger aus Karton (C) an

einer Gruppe von Artikeln wie Flaschen (B) mit einer Grundplatte (12), die so ausgebildet ist, daß für jeden Warenträger eine Aufstellzone (Z) vorgesehen ist, wobei jede Aufstellzone geeignet ist, einen aufgerichteten Warenträger mit mit Öffnungen versehener Oberwand und Bodenwand aufzunehmen, welche durch im Abstand voneinander befindliche Seitenwände miteinander verbunden sind, um eine allgemein röhrenförmige Struktur zu bilden, wobei die Grundplatte (12) eine Anzahl von beabstandeten angeordneten Öffnungen (a) in jeder der Aufstellzonen (Z) aufweist zur deckungsgleichen Ausrichtung mit entsprechenden beabstandeten Öffnungen (A) in der Oberwand und der Bodenwand des Trägers, und mit von der Grundplatte (12) getragenen Haltemitteln (34a) in jeder der Aufstellzonen (Z) zum Eingriff mit dem Träger nahe einer Seitenwand des Trägers, dadurch gekennzeichnet, daß eine Querwand (14, 16, 18) jeder Aufstellzone (Z) der Vorrichtung eine abwärts und nach außen geneigte Fläche (34) aufweist, die entfernt von der Grundplatte (12) in einer einwärts gerichteten Lippe endet und die Haltemittel bildet, so daß die natürliche Elastizität des Trägers, die dazu neigt, den Träger in seinen flachliegenden Zustand zurückzuführen, bewirkt, daß die Bodenwand (26) des Trägers durch den Halterand (34a) festgehalten wird und die Bestückung des Trägers mit den Artikeln (B) den Träger in Längsrichtung der Vorrichtung in eine aufrechtere Stellung verschiebt, wobei der Träger von dem Halterand frei wird.

2. Anbringvorrichtung nach Anspruch 1, dadurch gekennzeichnet, daß die Grundplatte eine Anzahl von beabstandeten Querwänden (14, 16, 18, 20) aufweist, die von einer Fläche (12a) der Platte herabhängen und teilweise die Aufstellzonen begrenzen und daß der Halterand auf einer freien Kante einiger dieser Wände entfernt von dieser einen Fläche angeordnet ist, daß jede Kante in den Zwischenraum eingreift, der eine Aufstellzone bildet.

3. Anbringvorrichtung nach Anspruch 2, dadurch gekennzeichnet, daß die Querwände eine erste Endwand (14) an einem Ende der Grundplatte, eine erste von der Endwand beabstandete Zwischenwand (16), eine zweite von der ersten Zwischenwand beabstandete Zwischenwand (18) und eine zweite Endwand (20) am gegenüberliegenden Ende der Grundplatte beabstandet von der zweiten Zwischenwand aufweisen, wobei jede der ersten Endwände und der ersten und zweiten Zwischenwände eine Haltelippe hat, die sich in die Richtung erstreckt, die der zweiten Endwand zugekehrt ist.

4. Anbringvorrichtung nach Anspruch 3, dadurch gekennzeichnet, daß sich eine längliche Rippe (22) von dem einen Ende der Grundplatte zu dem gegenüberliegenden Ende der Grundplatte erstreckt und jede dieser Querwände in zwei ähnliche Teile unterteilt, sodaß jede dieser Aufstellzonen durch den Zwischenraum zwischen einem gegenüberliegenden Paar dieser Querwandteile und einem Teil dieser länglichen Rippe gebildet wird.

5. Anbringvorrichtung nach Anspruch 4, dadurch gekennzeichnet, daß die seitliche Oberfläche jedes Querwandteils, die eine Begrenzung einer Aufstellzone bildet, mit einer Vertiefung (36, 38) versehen ist, die mit jeder Flaschenhals-Aufnahmeöffnung (a) in der Platte in dieser Aufstellzone fluchtet, wobei diese Vertiefung in Richtung dieser einen Oberfläche (12a) der Grundplatte erweitert ist und freien Raum bildet, um einen Teil der Umfanges eines Flaschenhalses aufzunehmen, wenn der Flaschenhals in einen in der Aufstellzone angeordneten Warenträger eingesetzt wird.

15 Revendications

1. Dispositif applicateur (10) pour poser au moins un porte-objets en carton (c) sur un groupe d'objets, tels que des bouteilles "B", lequel dispositif comporte une plaque de base (12) formée pour constituer une zone de positionnement (Z) pour chaque porte-objets, chaque zone de positionnement étant adaptée pour recevoir un porte-objets dressé ayant des parois supérieure et inférieure perforées reliées entre elles par des parois latérales espacées pour constituer une structure de forme générale tubulaire, cette plaque de base (12) présentant une multiplicité d'ouvertures espacées (a) formées dans chacune des zones de positionnement (Z) pour correspondre à des ouvertures espacées analogues (A) formées dans les parois supérieure et de base du porte-objets et des moyens d'arrêt (34a) portés par cette plaque de base (12) dans chacune des zones de positionnement (Z) pour coopérer avec le porte-objets, adjacents à l'une des parois latérales du porte-objets, caractérisé en ce qu'une paroi transversale (14, 16, 18) de chaque zone de positionnement (Z) de l'applicateur a une face (34) inclinée vers le bas et vers l'extérieur, qui se termine à une certaine distance de la plaque de base (12) sous la forme d'une lèvre dirigée vers l'intérieur (34a) constituant lesdits moyens d'arrêt de façon que l'élasticité naturelle du porte-objets, qui tend à ramener ce dernier dans son état non dressé, fait que la paroi de base (26) du porte-objets est arrêtée par la lèvre d'arrêt (34a) et que le chargement des objets (B) dans le porte-objets déplace celui-ci longitudinalement par rapport à l'applicateur pour l'amener dans une position plus verticale, libérant ainsi le porte-objets de la lèvre d'arrêt.

2. Dispositif applicateur selon la revendication 1, caractérisé en outre en ce que plaque de base comporte une multiplicité de parois transversales espacées (14, 16, 18, 20) partant vers le bas d'une surface (12a) de la plaque et définissant en partie ces zones de positionnement et en ce que la lèvre d'arrêt est formée sur un bord libre de certaines de ces parois à une certaine distance de ladite surface de telle sorte que chaque lèvre interfère avec l'espace définissant une zone de positionnement.

3. Dispositif applicateur selon la revendication 2, caractérisé en outre en ce que parois transversales comportent une première paroi terminale (14) à

une extrémité de la plaque de base, une première paroi intermédiaire (16) espacée de cette paroi terminale, une deuxième paroi intermédiaire (18) espacée de la première paroi intermédiaire, et une deuxième paroi terminale (20) à l'extrémité opposée de la plaque de base et espacée de la deuxième paroi intermédiaire, la première paroi terminale et la première et la deuxième paroi intermédiaire ayant chacune une lèvre d'arrêt s'étendant dans une direction faisant face à la deuxième paroi terminale.

4. Dispositif applicateur selon la revendication 3, caractérisé en outre en ce qu'une nervure longitudinale (22) s'étend depuis la première extrémité de la plaque de base vers l'extrémité opposée de celle-ci et divise chacune des parois transversales en deux parties similaires, chacune

des zones de positionnement étant constituée par l'espace compris entre une paire opposée de parties de parois transversales et une portion de cette nervure longitudinale.

5. Dispositif applicateur selon la revendication 4, caractérisé en outre en ce que la surface latérale de chaque partie de parois transversales constituant une frontière d'une zone de positionnement comporte un évidement (36, 38) aligné avec chaque ouverture (a) de réception de goulots de bouteilles formée dans la plaque dans cette zone de positionnement, cet évidement divergeant vers la surface (12a) de la plaque de base et procurant un passage pour recevoir une portion de la périphérie d'un goulot de bouteilles lorsque celui-ci est introduit dans un porte-objets disposé dans la zone de positionnement.

5

10

15

20

25

30

35

40

45

50

55

60

65

5

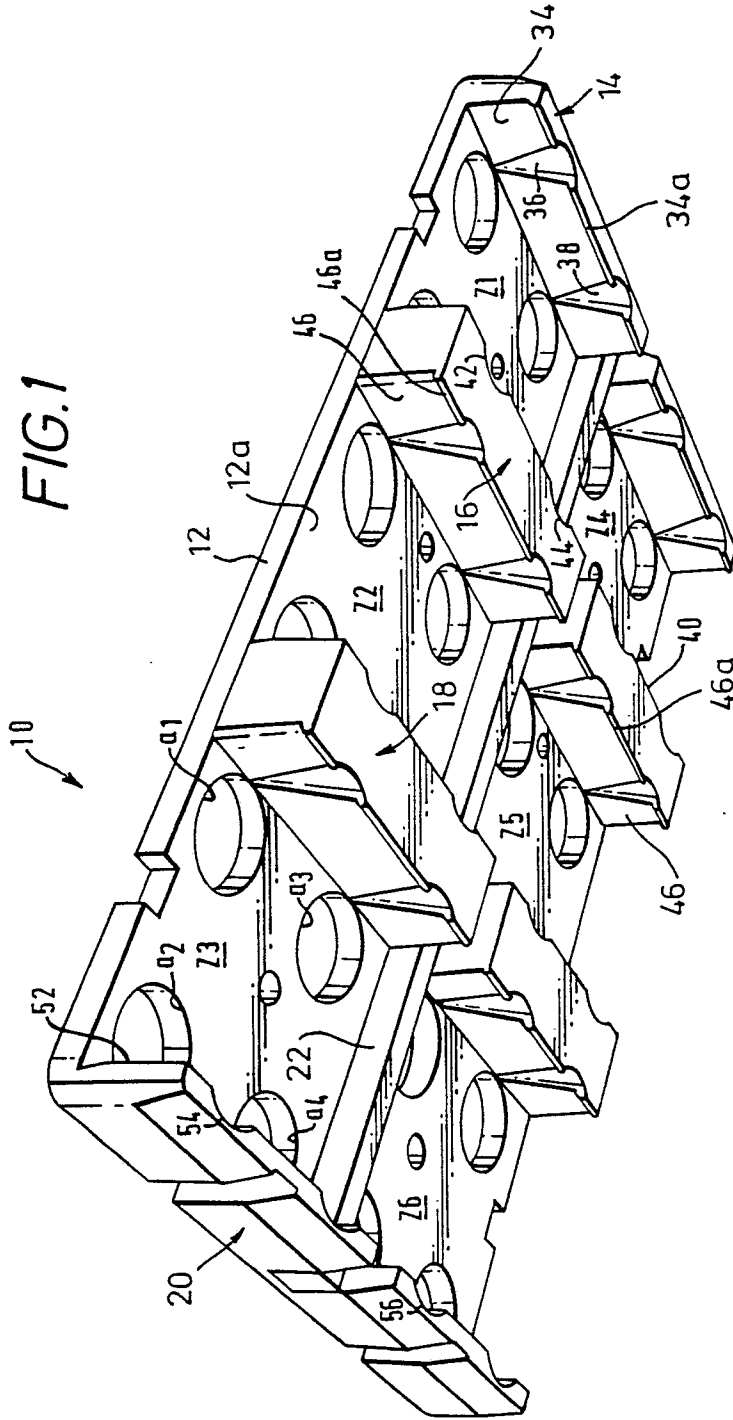

FIG. 2

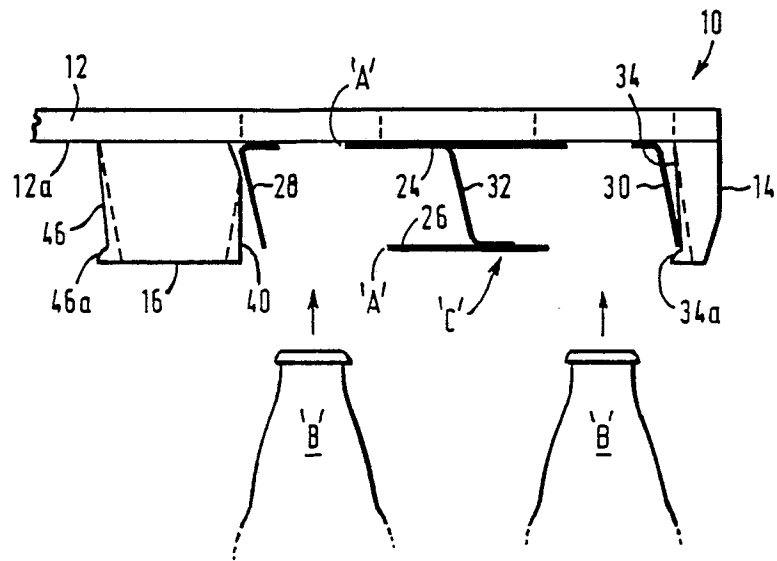

FIG. 3

