

J. McKAY.  
 CONVERTIBLE SHIRT.  
 APPLICATION FILED JUNE 28, 1916.

Patented Dec. 25, 1917.  
 2 SHEETS—SHEET 1.

1,251,069.

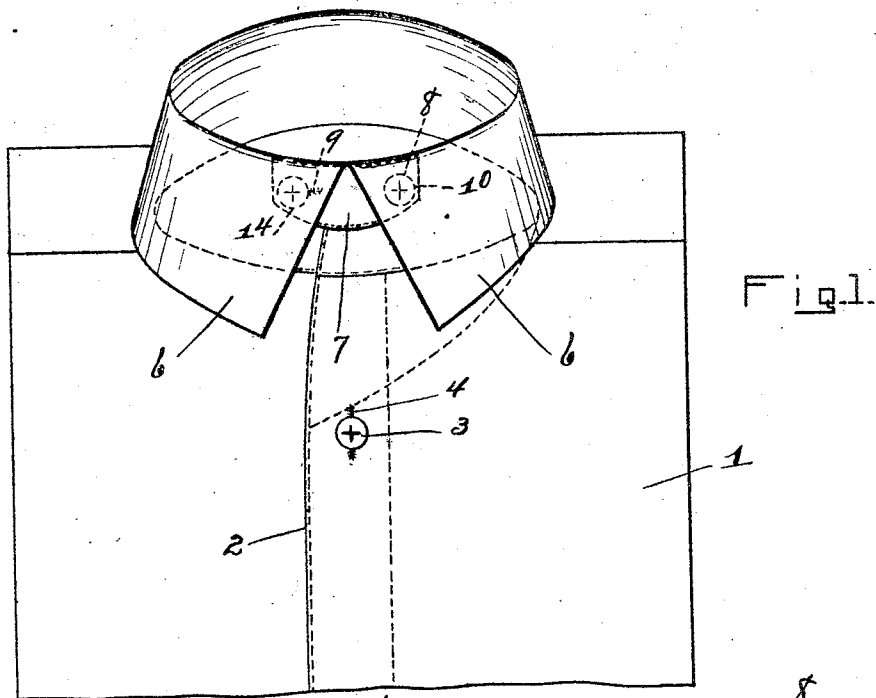

Fig. 1.

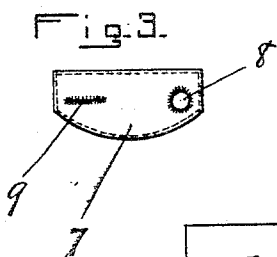

Fig. 3.

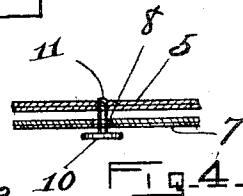

Fig. 4.

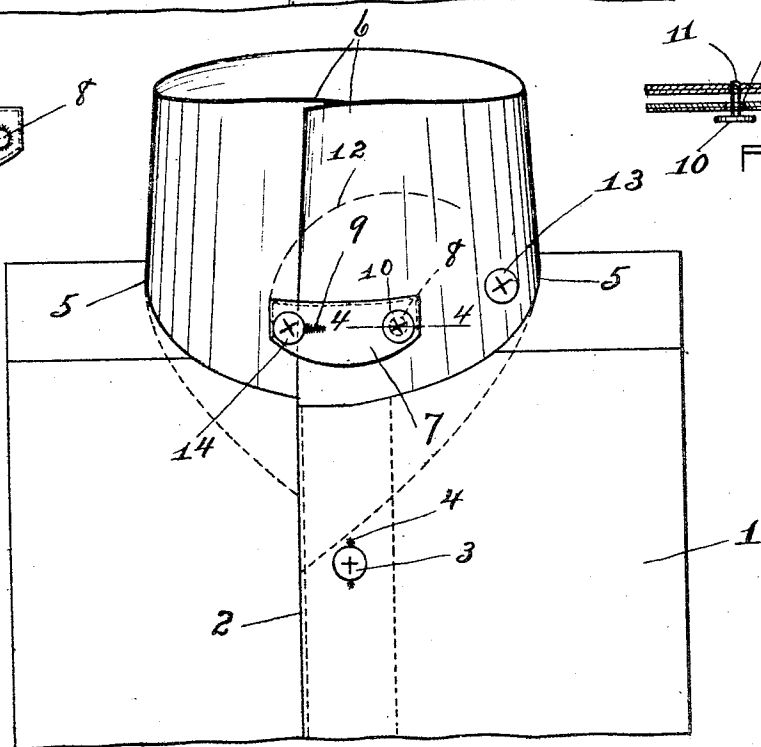

Fig. 2.

Inventor  
*Joseph McKay*  
 By *Frank C. Aubin*  
 Attorney

1,251,069.

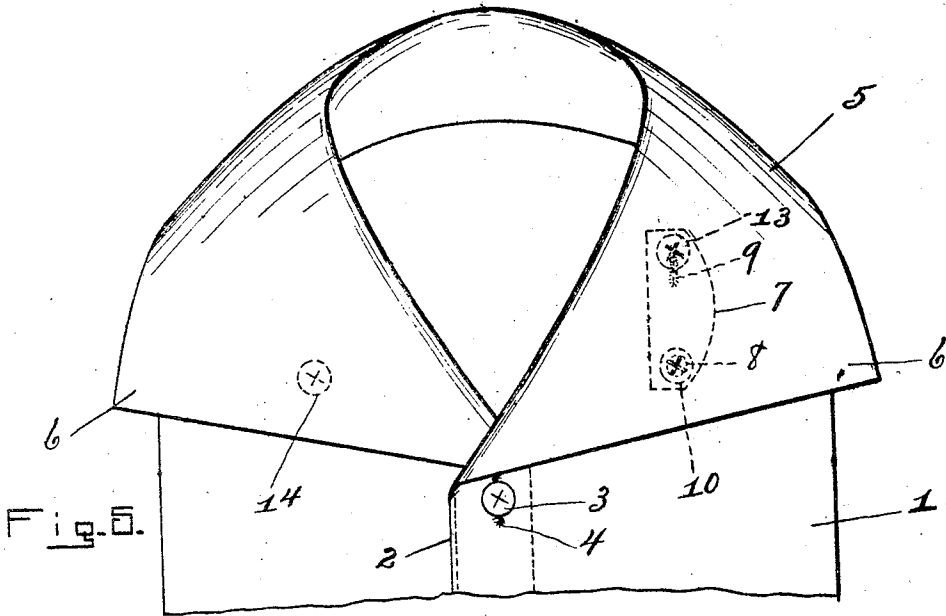

Fig. 5.

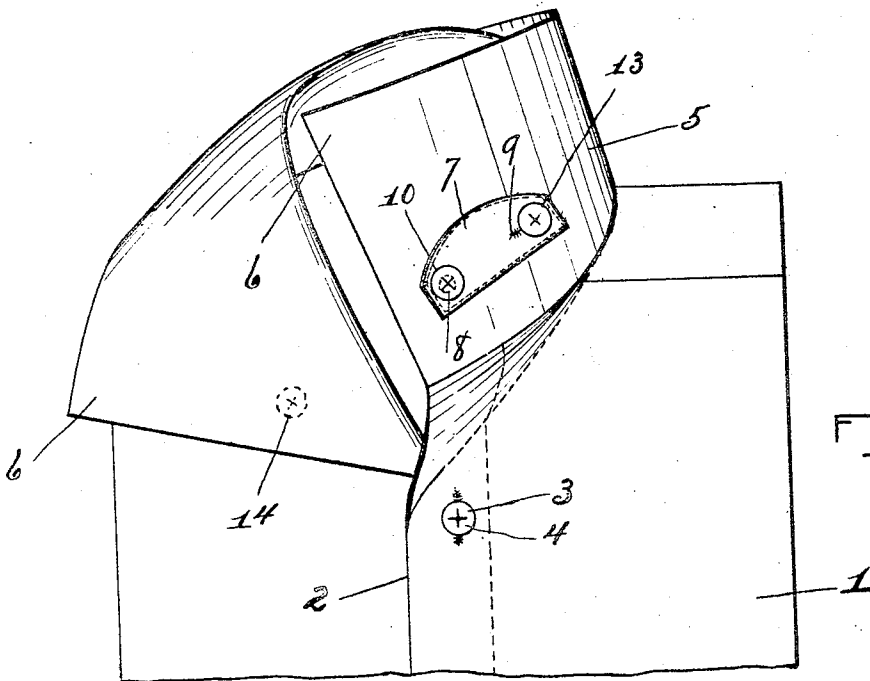

Fig. 6.

Inventor  
*Joseph McKay*  
By *Frank C. Curtis,*  
Attorney

# UNITED STATES PATENT OFFICE.

JOSEPH MCKAY, OF TROY, NEW YORK, ASSIGNOR TO HALL, HARTWELL & CO., OF TROY, NEW YORK, A FIRM COMPOSED OF WILLIAM L. HALL, JOSEPH MCKAY, BURTON K. WOODWARD, AND RALPH HUNTER.

## CONVERTIBLE SHIRT.

1,251,069.

Specification of Letters Patent.

Patented Dec. 25, 1917.

Application filed June 26, 1916. Serial No. 105,805.

*To all whom it may concern:*

Be it known that I, JOSEPH MCKAY, a citizen of the United States, residing at Troy, county of Rensselaer and State of New York, have invented certain new and useful Improvements in Convertible Shirts, of which the following is a specification.

The invention relates to such improvements and consists in the novel construction and combination of parts hereinafter described and subsequently claimed.

Reference may be had to the accompanying drawings, and the reference characters marked thereon, which form a part of this specification. Similar characters refer to similar parts in the several figures therein.

This invention relates to a type of convertible shirt provided with an attached deep collar which can be folded back to produce a sailor-collar effect, or which can be folded intermediately of its width to produce the effect of an ordinary detachable soft fold-collar having an upright band and a folded-over top.

Such convertible shirts are adapted to be worn with the sailor-collar effect in various athletic sports or as a work shirt, and with the soft-fold-collar effect as a negligée or semi-dress shirt.

To properly support the front portion of the collar with the appearance of an ordinary soft-fold-collar, a strap is employed to connect together the ends of the band-portion of the folded-collar, which strap extends across the front opening between the ends of the folded-over top of the collar, presenting the appearance of the long end of the band of an ordinary fold-collar.

When the shirt with a sailor-collar effect is worn, such disposition must be made of said strap as to conceal it from view; and this is commonly accomplished by folding the strap, when detached from one end of the band, back upon the other end of the band where it will be concealed from view beneath the widely folded collar.

The principal object of the present invention is to more readily and effectively conceal such a strap from view when the shirt is worn with the sailor-collar effect.

Figure 1 of the drawings is a front view of the upper portion of a folded-up shirt embodying my invention, with the collar

folded to produce the effect of an ordinary soft fold-collar.

Fig. 2 is a similar view with the collar unfolded to upright position to better show the strap which supports the front and connects together the ends of what corresponds with the band of an ordinary soft-fold collar.

Fig. 3 is a plan view of the strap before the same is attached to the shirt.

Fig. 4 is a horizontal cross-section taken through the permanent pivotal connection between the band and the strap.

Fig. 5 is a view similar to Fig. 1, showing the sailor-collar effect.

Fig. 6 is a similar view with a corner of the collar upturned to illustrate the manner in which the strap is secured in a rearwardly extended position, whereby it is concealed from sight when the shirt is used with the sailor-collar effect.

Referring to the drawings wherein the invention is shown in preferred form, 1 is the body of a shirt having an open front 2, with the usual buttons 3, and buttonholes 4, for detachably closing the front.

Permanently attached to the body is a deep collar 5, which is adapted to be widely folded over the shoulders of the shirt, as shown in Fig. 5, or to be more narrowly folded upon itself intermediately of its width, as shown in Fig. 1, to form an upright band-portion 5, and a folded-over top portion 6.

The strap 7, which is employed for detachably securing together and supporting the ends of the band-portion 5 in the latter form of the collar is provided in one end with an eyelet 8, and in its other end with a buttonhole 9.

The eyelet-end of the strap is permanently pivotally attached to the outer side of the band-portion 5, near one end thereof, as by means of a button 10, larger than the eyelet 8, secured to the band 5, by stitching 11, passing through the eyelet.

The pivotal connection thus formed permits the strap to be rotatively moved upon said pivotal connection along the curved line 12, to a forwardly extended position lapping the other end of the band, as shown in Figs. 1 and 2, or to a rearwardly extended position along the end of the band to which it

is pivotally attached, as shown in Figs. 5 and 6.

Attached to the outer side of the band-portion 5, at a suitable distance rearwardly of the button 10, is a button 13, adapted to engage the buttonhole, 9, when the strap is extended rearwardly, and thereby support the strap in flat position upon the under side of the widely folded collar, where it is concealed from view.

The other end of the band-portion 5, has attached to its outer side a button 14, adapted to engage the buttonhole 9, in the strap when the strap is forwardly extended to connect together the ends of the band, as shown in Figs. 1 and 2.

By attaching the strap to one end of the band-portion by means of a permanent pivotal connection, the strap forms a permanent part of the garment which prevents its loss during the laundry operation, and it is adapted to lie flat beneath the widely folded collar, giving said collar a smooth and undisturbed effect which can not be secured by means of a strap stitched to one end of the band and folded back upon the band beneath the widely folded collar.

For certain purposes of the invention the

strap may be permanently pivotally attached to the band, by means other than those 30 shown.

What I claim as new and desire to secure by Letters Patent is—

A convertible shirt having an attached deep collar adapted to be widely folded over upon the shoulders and being also adapted to be more narrowly folded upon itself intermediately of its width to form an upright band, a strap provided in one end with an eyelet, a button larger than said eyelet attached to the outer end of said band near one end by stitching extending through said eyelet, whereby the strap is permanently pivotally secured to the band and is rotatory upon its pivotal connection to a forward position lapping the other end of the band and to a rearward position along the end of the band to which it is pivotally attached, and a detachable connection between the other end of said strap and the respective end-portions of said band adapted to support the strap in either its forwardly or its rearwardly extended position.

In testimony whereof I have hereunto set my hand this 23d day of June 1916.

JOSEPH MCKAY.