

S. S. ARNOLD.

BUCKLE.

APPLICATION FILED DEC. 10, 1909.

963,201.

Patented July 5, 1910.

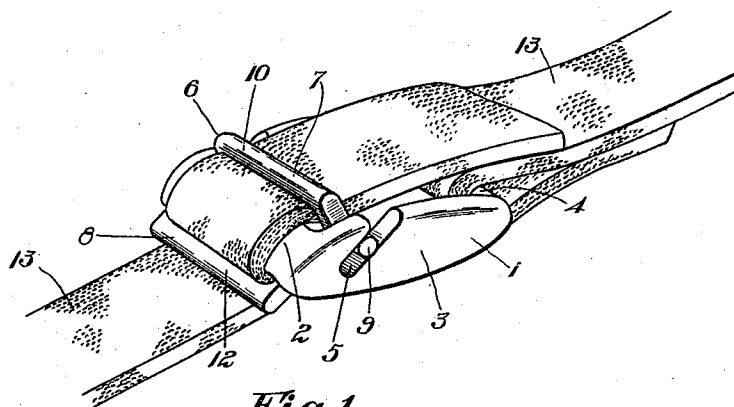

Fig. 1

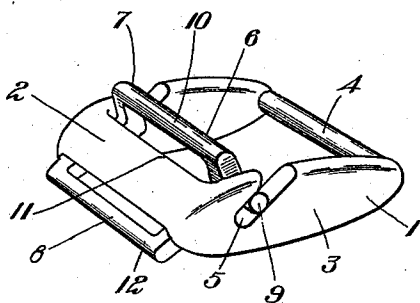

Fig. 2

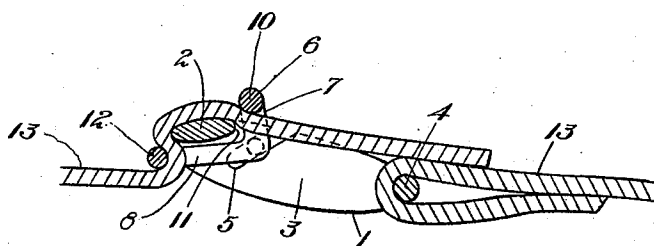

Fig. 3

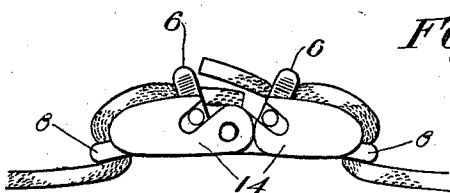

Fig. 4

Witnesses

J. Johnson

W. C. Muir

Inventor

by *S. S. Arnold*

E. J. Peterson & Company
Attys

UNITED STATES PATENT OFFICE.

SAMUEL STEPHEN ARNOLD, OF TORONTO, ONTARIO, CANADA.

BUCKLE.

963,201.

Specification of Letters Patent.

Patented July 5, 1910.

Application filed December 10, 1909. Serial No. 532,468.

To all whom it may concern:

Be it known that I, SAMUEL STEPHEN ARNOLD, a subject of the King of Great Britain, and resident of the city of Toronto, county of York, Province of Ontario, in the Dominion of Canada, have invented certain new and useful Improvements in Buckles, of which the following is a specification.

The invention relates to improvements in buckles, as described in the following specification and illustrated in the accompanying drawings that form part of the same.

The invention consists essentially in the novel construction and arrangement of parts, whereby the strap is gripped securely at two points in the length thereof by a gripping member co-acting with the end cross bar of the buckle frame.

The objects of the invention are, to obviate the cutting or tearing of the strap by toothed or pronged portions, to eliminate the necessity of forming holes in the strap, to allow of a more accurate adjustment of the strap, and to devise a simple construction of buckle which will grip the strap very securely without injury, thereby allowing the use of straps of textile material.

In the drawings, Figure 1 is a perspective view of my buckle showing a strap secured therein. Fig. 2 is a perspective view of the buckle stripped. Fig. 3 is a longitudinal sectional view through Fig. 1. Fig. 4 is a side view showing a slight modification of the buckle frame.

Like numerals of reference indicate corresponding parts in each figure.

Referring to the drawings, 1 is the buckle frame having the front cross bar 2 arranged to the upper edge of the side members 3, said front cross bar being preferably elliptical in cross section.

4 is a cross bar connecting the sides 3 at the opposite end of the buckle.

5 are narrow slots formed in the sides 3 of the buckle frame and extending from the upper edges of said sides in a downwardly and forwardly sloping direction.

6 is the gripping member formed of a pair of loops 7 and 8 secured together in angular relation the one to the other, said gripping member having the pins 9 extending outwardly from the point of juncture of the said loops. The pins 9 are adapted to fit into and slide freely in the slots 5 so that the upwardly extending loop 7 of the said member will move downwardly and

forwardly until its upper cross bar 10 is brought into close relation with the inner edge 11 of the front cross bar 2 of the buckle frame.

The front cross bar 12 of the loop 8 is arranged so that when the pins 9 have reached the bottom of the slots 5 the inner edge of the cross bar will be arranged slightly forward of the outer edge of the front cross bar 2.

In the use of this device the strap 13 is secured to the cross bar 4 in any suitable manner thus connecting the buckle to one end of the strap. The other end of the strap is threaded through the loop 8 from the underside and passed around the outer edge of the front cross bar 2 of the buckle frame and then threaded through the loop 7.

In adjusting the strap in the buckle, the portion extending between the cross bars 10 and 12 is loosened sufficiently to allow of its being gripped. The loose end is not however withdrawn from the loop 7. The main portion of the strap is then pulled taut, the said strap moving freely in the loop 8.

Immediately on the release of the strap the forward pull swings the gripping member upwardly so that the strap is gripped very tightly between the inner edge of the forward loop of the gripping member and the outer edge of the front cross bar of the buckle frame. The grip thus obtained is quite sufficient to hold the strap from slipping for a short period or until the looped portion between the loops of the gripping member is drawn down tightly. In order to do this the loose end of the strap which has not been withdrawn from the loop 7 is pulled upon, drawing the looped portion down tightly against the front cross bar of the frame,

In tightening the strap in the forward loop the gripping member is drawn forwardly and the pins 9 engaging the downwardly and forwardly sloping upper surface of the slots 5 cause the said gripping member to move downwardly, thus drawing the cross bar 10 into close relation with the inner edge 11 of the front cross bar 2 and thus gripping the strap securely at this point.

In order to take up the slack loop between the two portions of the gripping member, the backward pull draws the gripping member slightly backward, thus allowing the strap to be drawn tightly over the said front

cross bar 2 but immediately on the release of the end of the strap the tension on the gripping member causes the upper cross bar 10 to move again into closer relation with the front cross bar of the frame, squeezing the strap tightly between its forward underside and the upper inner side of the front cross bar. The strap when thus held is secured very firmly and without injury as the edges of the loops and frame are all smooth and rounded. It will therefore be seen that there will be no abrasive action, further it will be understood that the strap may be drawn any degree of distance through the said buckle, thus allowing very accurate adjustment of the strap.

The double gripping action of this buckle insures a perfect grip on the strap even under the most trying conditions and is particularly adapted for use in agricultural machinery where fabric belts are very desirable as it will hold the strap absolutely secure and without injury even under excessive vibration.

In the form of the device shown in Fig. 4, the frames 14 are made slightly shorter than that shown in Fig. 1 and said frames are pivotally secured together at their inner ends. Two ends of a strap may thus be adjustably secured to the buckle and the buckle may travel around a very small pulley or roller without straining the strap, as the said buckle will bend in the middle and allow the strap to hug closely to the said roller or pulley.

What I claim as my invention is:—

1. In a buckle, a frame having a rigid cross-bar extending between the sides at the forward end and presenting outer and inner edges, and a gripping member movably supported from said frame and adapted to receive a strap and be moved by said strap to exert a gripping pressure thereon against said rigid cross-bar at its outer and inner edges respectively.

2. In a buckle, a frame having a cross bar

at one end thereof, and a gripping member supported in said frame and having a loop extending forwardly beneath the front cross bar of said frame and a loop arranged in angular relation to the aforesaid loop and extending upwardly adjacent to the inner side of said cross bar, said loops co-acting with said cross bar to grip the strap at the outer and inner sides of said cross bar.

3. In a buckle, a frame having a cross bar at one end thereof presenting outer and inner edges and a pair of slots formed in the sides, said slots extending in a forwardly and downwardly sloping direction, and a gripping member forming a pair of loops arranged in angular relation the one to the other and having pins projecting from the sides thereof adapted to extend into said slots, the loops of said gripping member being arranged to co-act with said cross bar by gripping the strap at the outer and inner edges of said bar.

4. In a buckle, a frame having a broad flat cross bar at the forward end arranged at the upper edge of the sides and a pair of slots extending downwardly and forwardly from the upper edge, and a gripping member forming a pair of loops rigidly secured together and arranged in angular relation one to the other and pins extending outwardly from the juncture of said loops and adapted to extend into said slots, the forward extending loop having its front cross bar adapted to co-act with the outer edge of the frame cross bar and the upwardly extending loop having its cross bar adapted to co-act with the inner edge of said frame cross bar.

Signed at the city of Toronto, county of York, Province of Ontario, Canada, this 20th day of November 1909.

SAMUEL STEPHEN ARNOLD.

Witnesses:

H. DENNISON,
Wm. C. Muir.