



(51) International Patent Classification:

E05B 47/00 (2006.01) A47F 5/00 (2006.01)
A47F 1/04 (2006.01) A47F 1/00 (2006.01)

(21) International Application Number:

PCT/US2022/016082

(22) International Filing Date:

11 February 2022 (11.02.2022)

(25) Filing Language:

English

(26) Publication Language:

English

(30) Priority Data:

63/149,026 12 February 2021 (12.02.2021) US
63/197,045 04 June 2021 (04.06.2021) US

(71) Applicant: INVUE SECURITY PRODUCTS INC.

[US/US]; 9201 Baybrook Lane, Charlotte, NC 28277 (US).

(72) Inventors: HELMAN, Christopher, Richard; 232 Har-

gett Court, Charlotte, NC 28211 (US). GRANT, Jeffrey, A.; 1526 Starbrook Drive, Charlotte, NC 28210 (US). BLANCHARD, Wesley, J.; 1543 Kilburn Lane, Fort Mill, SC 29715 (US). BOHON, Steven, R.; 810 Mill Creek Lane, Charlotte, NC 28209 (US).

(74) Agent: KIRK, Trent, A.; InVue Security Products Inc.,

9201 Baybrook Lane, Charlotte, NC 28277 (US).

(81) Designated States (unless otherwise indicated, for every

kind of national protection available): AE, AG, AL, AM, AO, AT, AU, AZ, BA, BB, BG, BH, BN, BR, BW, BY, BZ, CA, CH, CL, CN, CO, CR, CU, CZ, DE, DJ, DK, DM, DO, DZ, EC, EE, EG, ES, FI, GB, GD, GE, GH, GM, GT, HN, HR, HU, ID, IL, IN, IR, IS, IT, JM, JO, JP, KE, KG, KH, KN, KP, KR, KW, KZ, LA, LC, LK, LR, LS, LU, LY, MA, MD, ME, MG, MK, MN, MW, MX, MY, MZ, NA, NG, NI, NO, NZ, OM, PA, PE, PG, PH, PL, PT, QA, RO, RS, RU,

(54) Title: MERCHANDISE DISPLAY SECURITY SYSTEMS AND METHODS

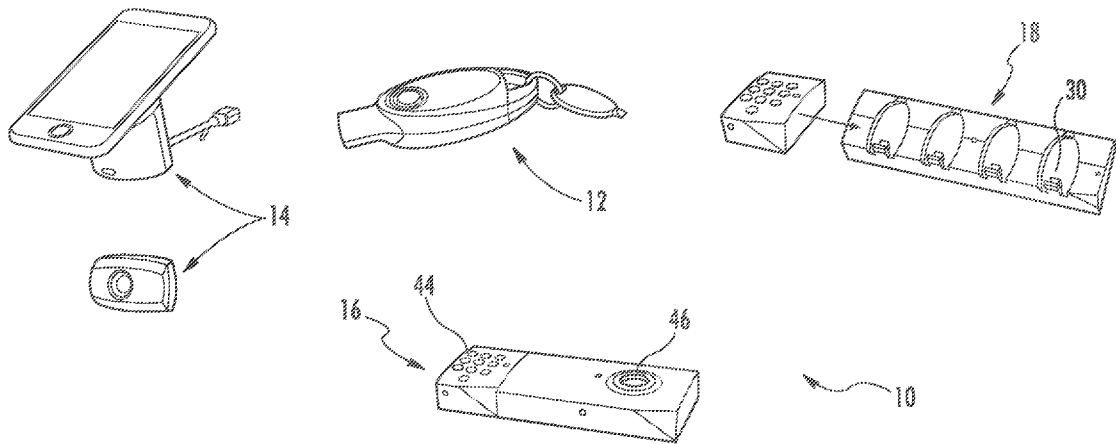

FIG. 1

(57) Abstract: Merchandise security systems and methods are provided. In one example, a merchandise security system includes a plurality of locks configured to protect one or more items from theft, each of the plurality of locks configured to wirelessly communicate with one or more mobile computing devices. Each of the plurality of locks is configured to establish communication with one or more of the mobile computing devices using a first communication protocol. Each of the plurality of locks is configured to subsequently communicate with one or more of the mobile computing devices using a second communication protocol, different than the first communication protocol, for identifying one or more of the plurality of locks to be unlocked. The one or more of the plurality of locks identified by the one or more mobile computing devices is configured to be unlocked in response to subsequently communicating with the one or more of the plurality of locks using the first communication protocol.



RW, SA, SC, SD, SE, SG, SK, SL, ST, SV, SY, TH, TJ, TM,
TN, TR, TT, TZ, UA, UG, US, UZ, VC, VN, WS, ZA, ZM,
ZW.

(84) Designated States (*unless otherwise indicated, for every kind of regional protection available*): ARIPO (BW, GH, GM, KE, LR, LS, MW, MZ, NA, RW, SD, SL, ST, SZ, TZ, UG, ZM, ZW), Eurasian (AM, AZ, BY, KG, KZ, RU, TJ, TM), European (AL, AT, BE, BG, CH, CY, CZ, DE, DK, EE, ES, FI, FR, GB, GR, HR, HU, IE, IS, IT, LT, LU, LV, MC, MK, MT, NL, NO, PL, PT, RO, RS, SE, SI, SK, SM, TR), OAPI (BF, BJ, CF, CG, CI, CM, GA, GN, GQ, GW, KM, ML, MR, NE, SN, TD, TG).

Published:

— *with international search report (Art. 21(3))*

MERCHANDISE DISPLAY SECURITY SYSTEMS AND METHODS

CROSS REFERENCE TO RELATED APPLICATIONS

[0001] This application claims the benefit of priority to U.S. Provisional Application No. 63/149,026, filed on February 12, 2021, and U.S. Provisional Application No. 63/197,045, filed on June 4, 2021, the entire contents of each of which are hereby incorporated by reference.

FIELD OF THE INVENTION

[0002] The present invention relates generally to merchandise display security systems, locks, devices, computer program products, and methods for protecting items of merchandise from theft and/or the exchange of various types of information in a wireless network.

BACKGROUND OF THE INVENTION

[0003] It is common practice for retailers to display items of merchandise for sale on a security device, such as a display hook or a display fixture, within security packaging commonly referred to as a "safer", or otherwise on a display surface. The security device or safer displays an item of merchandise so that a potential purchaser may examine the item when deciding whether to purchase the item. The small size and relative expense of the item, however, makes the item an attractive target for shoplifters. A shoplifter may attempt to detach the item from the security device, or alternatively, may attempt to remove the security device from the display area along with the merchandise. Items of merchandise may also be secured using a display stand to allow users to sample the item for potential purchase. In some instances, the security device is secured to a display support using a lock operated by a key, for example, a mechanical lock. In other instances, the security device is secured to the display support using a lock operated by an electronic key to arm and disarm the security device.

BRIEF SUMMARY

[0004] Various embodiments of merchandise security systems, devices, and methods are provided. In one example, a security system includes a plurality of locks configured to protect one or more items from theft, each of the plurality of locks configured to wirelessly communicate with one or more mobile computing devices. Each of the plurality of locks is configured to establish communication with one or more of the mobile computing devices using a first communication protocol. Each of the plurality of locks is configured to subsequently communicate with one or more of the mobile computing devices using a second communication protocol, different than the first communication protocol, for identifying one or

more of the plurality of locks to be unlocked. The one or more of the plurality of locks identified by the one or more mobile computing devices is configured to be unlocked in response to subsequently communicating with the one or more of the plurality of locks using the first communication protocol.

[0005] In another embodiment, a method is provided and includes establishing communication between each of a plurality of locks and one or more mobile computing devices using a first communication protocol, each of the plurality of locks configured to protect one or more items from theft. The method also includes subsequently communicating between one or more of the plurality of locks and one or more of the mobile computing devices using a second communication protocol, different than the first communication protocol, for identifying one or more of the plurality of locks to be unlocked. The method further includes unlocking the one or more of the plurality of locks identified by the one or more mobile computing devices in response to subsequently communicating with the one or more of the plurality of locks using the first communication protocol.

[0006] In another embodiment, a security system includes a plurality of locks configured to protect one or more items from theft, each of the plurality of locks configured to wirelessly communicate with one or more mobile computing devices, and a plurality of electronic keys configured to communicate with one or more of the plurality of locks for unlocking the locks. Each of the plurality of locks is configured to establish communication with one or more of the mobile computing devices using a first communication protocol, and each of the plurality of locks is configured to subsequently communicate with one or more of the mobile computing devices using a second communication protocol, different than the first communication protocol, for identifying one or more of the plurality of locks to be unlocked. The one or more of the plurality of locks identified by the one or more mobile computing devices is configured to be unlocked in response to subsequently communicating with the one or more of the plurality of locks using the first communication protocol, and each of the plurality of electronic keys is configured to communicate with each of the plurality of locks using a third communication protocol different than the first and second communication protocols.

BRIEF DESCRIPTION OF THE DRAWINGS

[0007] FIG. 1 illustrates a merchandise security system according to one embodiment of the present invention.

[0008] FIG. 2 illustrates a merchandise security system according to another embodiment of the present invention.

[0009] FIG. 3 illustrates a key in communication with a remote device via a cloud according to one embodiment.

- [0010] FIG. 4 illustrates a plurality of keys with different authorization levels according to one embodiment.
- [0011] FIG. 5 is a plan view of an electronic key according to one embodiment.
- [0012] FIG. 6 is a perspective view of the electronic key shown in FIG. 5.
- [0013] FIG. 7 is a plan view of an electronic key according to another embodiment.
- [0014] FIG. 8 is a perspective view of the electronic key shown in FIG. 7.
- [0015] FIG. 9 is a plan view of an electronic key according to another embodiment.
- [0016] FIG. 10 is a perspective view of the electronic key shown in FIG. 9.
- [0017] FIG. 11 is a perspective view of a merchandise security device according to one embodiment.
- [0018] FIG. 12 is a perspective view of an electronic key according to one embodiment.
- [0019] FIG. 13 is a cross-sectional view of the electronic key shown in FIG. 12.
- [0020] FIG. 14 is a perspective view of a merchandise security device in a locked and unlocked position according to one embodiment.
- [0021] FIG. 15 is a perspective view of a merchandise security device in a locked and unlocked position according to another embodiment.
- [0022] FIG. 16 is a plan view of a charging station according to one embodiment.
- [0023] FIG. 17 is a perspective view of the charging station shown in FIG. 16.
- [0024] FIG. 18 illustrates a merchandise security system according to one embodiment.
- [0025] FIG. 19 illustrates an electronic key in communication with a computing device according to one embodiment.
- [0026] FIG. 20 illustrates top and bottom perspective views of an electronic key according to another embodiment.
- [0027] FIG. 21 illustrates plan and side views of the electronic key shown in FIG. 20.
- [0028] FIG. 22 is a plan view of a programming or authorization station according to one embodiment.
- [0029] FIG. 23 is a perspective view of the programming or authorization station shown in FIG. 22.
- [0030] FIG. 24 is another perspective view of the programming or authorization station shown in FIG. 22.
- [0031] FIG. 25 is a schematic illustration of a plurality of sensors and alarm nodes communicating in a wireless network according to one embodiment.
- [0032] FIG. 26 is a schematic of infrastructure and security devices within a wireless network according to one embodiment of the present invention.
- [0033] FIG. 27 is a perspective view of a system in a wireless network according to one embodiment.
- [0034] FIG. 28 is a perspective view of a system in a wireless network according to one embodiment.

- [0035] FIG. 29 is a perspective view of a system in a wireless network according to one embodiment.
- [0036] FIG. 30 is a perspective view of a system in a wireless network according to one embodiment.
- [0037] FIG. 31 is a perspective view of a system in a wireless network according to one embodiment.
- [0038] FIG. 32 shows various security devices configured for use in a wireless network according to additional embodiments.
- [0039] FIG. 33 shows a security device configured for use in a wireless network according to one embodiment.
- [0040] FIG. 34 shows a security device configured for use in a wireless network according to one embodiment.
- [0041] FIG. 35 shows a security device configured for use in a wireless network according to one embodiment.
- [0042] FIG. 36 shows a security device configured for use in a wireless network according to one embodiment.
- [0043] FIG. 37 is a perspective view of a system in a wireless network according to one embodiment.
- [0044] FIG. 38 is a perspective view of a system in a wireless network according to one embodiment.
- [0045] FIG. 39 is a perspective view of a system in a wireless network according to one embodiment.
- [0046] FIG. 40 is a perspective view of a system in a wireless network according to one embodiment.
- [0047] FIG. 41 is a perspective view of a system in a wireless network according to one embodiment.
- [0048] FIG. 42 is a perspective view of a system in a wireless network according to one embodiment.
- [0049] FIG. 43 is a perspective view of a merchandise display security system according to one embodiment.
- [0050] FIG. 44 illustrates various components of a merchandise display security system according to one embodiment.
- [0051] FIGS. 45A-C illustrate internal can cross-sectional views of a lock according to one embodiment.
- [0052] FIG. 46A-B are perspective views of different locks according to additional embodiments.
- [0053] FIG. 47 is a perspective view of a merchandise display security system according to another embodiment.
- [0054] FIG. 48 is a perspective view of a lock mounted to a fixture according to one embodiment.
- [0055] FIG. 49 is a perspective view of a fixture having locks mounted thereto according to one embodiment.
- [0056] FIGS. 50A-B are perspective views of different locks according to additional embodiments.
- [0057] FIG. 51 is a perspective view of a lock and an electronic key according to one embodiment.

[0058] FIGS. 52A-B are perspective views of a lock having a modular component according to one embodiment.

[0059] FIG. 53A-C illustrate the operation of various locks according to additional embodiments.

[0060] FIGS. 54A-C illustrate the operation of various locks according to additional embodiments.

DETAILED DESCRIPTION OF EMBODIMENTS OF THE INVENTION

[0061] The following disclosure includes various embodiments of systems, devices, methods, and computer program products. It should be understood that any combination of embodiments disclosed herein have been envisioned. Thus, discussion of one particular embodiment is not intended to be made at the exclusion of any other embodiments.

[0062] Referring now to the associated figures, one or more embodiments of a merchandise display security system are shown. In the embodiments shown and described herein, the system includes an electronic key and a merchandise security device. Merchandise security devices suitable for use with the electronic keys include, but are not limited to, a security display (e.g. alarming stand or device), security fixture (e.g. locking hook, shelf, cabinet, etc.), cabinet locks, door locks, cable wraps, cable locks, or security packaging (e.g. merchandise keeper) for an item of merchandise. However, an electronic key (also referred to herein as a programmable key or generally as a key) may be useable with any security device or locking device that utilizes power transferred from the key to operate a mechanical and/or electronic lock mechanism and/or utilizes data transferred from the key to authorize the operation of a lock mechanism and/or arming or disarming an alarm circuit. In other words, an electronic key is useable with any security device or locking device that requires power transferred from the key to the device and/or data transferred from the key to the device. Further examples of security devices and locking devices include, but are not limited to, a door lock, a drawer lock or a shelf lock, as well as any device that prevents an unauthorized person from accessing, removing or detaching an item from a secure location or position. Although the following discussion relates to a system for use in a retail store, it is understood that the system is also suitable for other industries, such as hospital, restaurants, etc. In some embodiments, the merchandise security systems, merchandise security devices, and electronic keys are similar to those disclosed in PCT Publication WO 2020/227513 (and related U.S. Appl. No. 17/261,757), entitled Merchandise Display Security Systems and Methods, U.S. Publication No. 2012/0047972, entitled Electronic Key for Merchandise Security Device, U.S. Patent No. 10,258,172, entitled Systems and Methods for Acquiring Data from Articles of Merchandise on Display, U.S. Patent No. 10,210,681, entitled Merchandise Display Security Systems and Methods, U.S. Publ. No. 2018/0365948, entitled Tethered Security System with Wireless Communication, and U.S. Publication No. 2016/0335859, entitled Systems and Methods for

Remotely Controlling Security Devices, the entire disclosures of which are incorporated herein by reference in their entirety.

[0063] FIG. 1 illustrates one embodiment of a system 10. In this embodiment, the system generally includes an electronic key 12, one or more merchandise security devices 14, a programming or authorization station 16, and a charging station 18. FIG. 2 shows an embodiment of a system 10 that is part of a network of merchandise security devices. According to some embodiments, the network enables communication between a plurality of electronic keys and merchandise security devices. The network may be cloud-based and include a cloud 22 for receiving data from, and/or providing data to, the electronic keys and/or merchandise security devices. The cloud 22 may facilitate communication with one or more computing devices 26 (e.g., a mobile device, tablet, or computer). For example, the cloud 22 may be used to transfer data to one or more remote locations or computing devices 26 where the data may be reviewed and analyzed. The computing devices 26 may be located at any desired location, such as in the same retail store as the security devices 14 and/or electronic keys 12. In some cases, the computing device 26 may belong to a retail store associate (e.g., a mobile device) or be a backend computer used by a retailer or corporation. The network may be a wireless network including a plurality of nodes 20 that are configured to communicate with one another, one or more electronic keys 12, and/or one or more merchandise security devices 14. The network may be any suitable network for facilitating wireless communication such as, for example, a mesh, star, multiple star, repeaters, IoT, etc. networks. The nodes 20 and/or security devices 14 may be located within one or more zones. In some cases, the nodes and the security devices may be integrated with one another such that the security device operates as a node. A gateway 24 or hub or “host” may be employed to allow for communication between the one or more nodes 20 and the cloud 22. In some embodiments, all communication within the network is wireless, such as via radio-frequency signals (e.g., Sub GHz ISM band or 2.4 GHz), Bluetooth, LoRa, and Wi-Fi, although other types of wireless communication may be possible.

[0064] In some embodiments, each merchandise security device 14 and/or electronic key 12 is configured to store various types of data. For example, each merchandise security device 14 and/or key 12 may store a serial number of one or more merchandise security devices 14, a serial number of one or more items of merchandise, the data and time of activation of the key, a user of the key, a serial number of the key, a location of the security device, a location of the item of merchandise, a department number within a retail store, number of key activations, a type of activation (e.g., “naked” activation, activation transferring only data, activation transferring power, activation transferring data and power), and/or various events (e.g., a merchandise security device has been locked, unlocked, armed, or disarmed). For instance, FIG. 3 shows that the identity of a user of an electronic key 12 may be communicated to a remote location or device 26.

This information may be transmitted to the remote location or device 26 upon each activation of the key 12 or at any other desired period of time, such as upon communication with a programming or authorization station 16. Thus, the data transfer from the electronic key 12 and/or security device 14 may occur in real time or automatically in some embodiments. In some cases, the electronic key 12, security device 14, and/or programming station 16 may be configured to store the data and transfer the data to a remote location or device 26. Authorized personnel may use this data to take various actions using the computing device 26, such as to audit and monitor associate activity, authorize or deauthorize particular keys 12, determine the battery life of a key 12, audit merchandise security devices 14 (e.g., ensure the security devices are locked or armed), arm or disarm the security device, lock or unlock the security device, lock or unlock a sensor 25 attached to an item of merchandise to a base or stand 35 removably supporting the sensor, etc. (see, e.g., FIG. 30). Moreover, such information may be requested and obtained on demand using the computing device 26, such as from the electronic keys 12, security devices 14, and/or the programming station 16.

[0065] In some cases, the data may include battery analytics of an electronic key 12. For example, the battery analytics may include monitoring the battery voltage of an electronic key 12 when the key is placed on a charging station 18 and the time taken to reach full charge. These values may be used to determine depth of discharge. The battery analytics may be indicative of a battery that is nearing its end of life. A retailer or other authorized personnel may take various actions using this information, such as replacing the key or disabling the key to prevent battery swelling and housing failure.

[0066] In one embodiment, the electronic key 12 is configured to obtain data from a merchandise security device 14 (e.g., a lock). For example, the merchandise security device 14 may store various data regarding past communication with a previous electronic key 12 (e.g., key identification, time of communication, etc.), and when a subsequent electronic key communicates with the same merchandise security device, the data is transferred to the electronic key. Thus, the merchandise security device 14 may include a memory for storing such data. In some cases, the merchandise security device 14 includes a power source for receiving and storing the data, while in other cases, the power provided by the electronic key 12 is used for allowing the merchandise security device to store the data. The electronic key 12 may then communicate the data for collection and review, such as at a remote location or device 26. In some instances, communication between the electronic key 12 and the programming or authorization station 16 may allow data to be pulled from the electronic key and communicated, such as to a remote location or device 26. In other cases, the electronic key 12 may be configured to obtain data from merchandise security devices 14 (e.g., a security display), such as an identification of the merchandise security device, the type of item of merchandise on display, an identification of the item of merchandise, and/or the system health

of the security device and/or the item of merchandise. The electronic key 12 may store the data and provide the data to a remote location or device 26 directly or upon communication with the programming or authorization station 16. As such, the electronic keys 12 may be a useful resource for obtaining various types of data from the merchandise security devices 14 without the need for wired connections or complex wireless networks or systems.

[0067] In one embodiment, the security device 14 may communicate its identifier using various techniques. For example, in some cases the security device 14 may have a memory configured to store a serial number and is able to communicate that serial number to the electronic key 12 using bi-directional communication. In instances where the security device 14 may not have a memory, power source, and/or the ability for bi-directional communication (e.g., a cable wrap or locking hook), the security device may have an RFID tag, an NFC tag, or the like that stores an identifier for the security device (e.g., a serial number). Such security devices may be similar to that disclosed in U.S. Patent No. 9,133,649, entitled Merchandise Security Devices for Use with an Electronic Key, the entire disclosure of which is incorporated herein by reference in their entirety. In some examples, the tag may be attachable (e.g., via adhesive) to existing security devices 14 such that it is readily adaptable to current devices, or the tag may be integrated within the security device. The electronic key 12 may be configured to deliver power to the tag to read the identifier of the tag, such as for a passive tag, although the tags may be passive or active. The electronic key 12 may store a number of authorized identifiers in memory (e.g., via a look-up table) and may then determine if the read identifier is in its memory. Alternately, the electronic key 12 may be configured to wirelessly connect to a network device 26 with a look-up table. Either the electronic key 12 itself or the network device 26 can then determine if the particular key or user of that key is authorized to unlock the security device 14 with the read identifier. The identifier may be unique to the security device 14 or may be a more generic identifier, such as for example, a “6-sided box” or a department such as “healthcare” or all of the above. Once authorization has been obtained, only then will the electronic key be capable of delivering power to the security device 14 to successfully operate the lock and unlock it. If there is no authorization, the electronic key 12 does not continue this cycle, and the lock never unlocks. Thus, embodiments of the present invention may be configured to communicate with any type of security device 14 for performing various auditing, zone control, and planogram analysis based on identification of the security device.

[0068] In one embodiment, the electronic key 12 and security device 14 may communicate with one another via NFC to transmit data when the key and security device are positioned near one another or in direct contact with one another. An NFC tag may include various components, such as an antenna or a coil and one or more chips that define an electrical circuit. The antenna may be used for effectuating

communication with an electronic key 12, which may be activated via a magnetic field. For example, a magnetic field may be generated by the electronic key 12 to communicate with an NFC tag.

[0069] In some embodiments where the electronic key 12 is configured to transfer power inductively, as explained in further detail below, and is equipped to communicate using NFC or RFID, the inductive coil of the key may be configured to use the same coil for both data transfer and power transfer. In some cases, the electronic key 12 is configured to switch the coil between an energy transfer mode and an NFC or RFID receiver circuit. In other examples, a plurality of security devices 14 may be “nested” with one another such that authorization to one of the nested security devices results in all security devices being disarmed or unlocked. For instance, a plurality of locks could be paired to one another such that successful communication between any one of the locks and the electronic key 12 results in all of the locks being unlocked.

[0070] In some embodiments, the merchandise security devices 14 include wireless functionality for communicating within the network. For example, the merchandise security devices may communicate wirelessly with each other, items of merchandise, electronic keys 12, computing devices 26, and/or nodes, including but not limited to communicating the various types of data discussed herein. Thus, in some cases, the computing devices 26 may communicate directly with the security devices 14 and/or electronic keys 12.

[0071] One embodiment of such a wireless system includes various types of wireless networks capable of being used in conjunction with embodiments disclosed herein. In some cases, the wireless system includes fully integrated hardware, software, and data analytics which effectively eliminates or makes negligible the added hardware costs of a data integrated solution--all other features remaining constant. In some embodiments, the wireless system is configured to adapt to a changing market where an increasing number of smartphones leverage Qi based inductive charging and exposed data ports no longer exist. For instance, in an embodiment where the security device 14 includes a sensor 25 and a base or stand 35 (see, e.g., FIG. 30), the sensor may utilize Qi technology, such as a Qi coil that is configured to communicate with a corresponding coil in the item of merchandise. In addition, embodiments of the wireless system may be configured to provide a common wireless interface and IP gateway for future networked products leveraging the various wireless networks discussed herein. Various modes of operation can be implemented according to wireless system embodiments. In one example, a non-IP connected mode could be employed whereby a customer choosing not to subscribe to a SaaS service is able to leverage the wireless system’s display merchandising and security features independent of a connection to an IP enabled network. Another mode may include an IP-connected mode, which may provide information, e.g., regarding security armed and power status and alarm alerts alarm activity on a local store basis. Additionally, this mode may provide

access to other web applications such as product documentation, product videos, product selector guides and support contact information. An additional mode is also an IP-connected network that includes a SaaS subscription service that allows access to the full capabilities of the wireless system, such as the data communication among various devices described herein.

[0072] In some embodiments, wireless communication may occur using a proprietary wireless network, for example, each security device 14 may be configured to communicate with a central hub in a star network configuration. Each security device 14 may include a transceiver (e.g., a sub-GHz transceiver) configured to communicate data to and from a common central hub or “host” 24, such as the various types of information and data discussed herein, as well as information about power status and security breaches to the host without the need for a separate data connection to a smart hub or controller. It is understood that any number of nodes 20 could be employed to facilitate communication between the security devices 14 and the host, such one or more local nodes. In one embodiment, each security device 14 is configured to communicate its power and security status, security breaches (alarm notifications), as well as various other identification data for the security device and/or the item of merchandise, to the host 24. In some embodiments, an entire retail store may be serviced by a single host 24 without the need for repeaters and is not practically limited by the number of security devices in the network. In one embodiment, the host 24 may be configured to generate a security signal, such as an audible and/or a visible alarm signal. In some cases, the volume of the security signal is adjustable. When any security device 14 detects a security event, the security device is configured to send a signal to the host 24. The retailer has the option of choosing the level of notification for the security event, for example, a loud audible alarm, a lower volume, audible notification, or no audible alarm notification. Among other features, the system may include the ability to program alarm notifications. For instance, a retailer may choose silent alerts, optical alerts, and adjustable volume and tone audible alerts or combinations of these alerts. Additionally, the host 24 could be configured to indicate a security breach by changing colors (e.g., from gold to red and or by flashing intermittently). The audible and visual alert signals can be used independently or together.

[0073] As discussed herein, electronic keys 12 may be incorporated with the various system embodiments. Electronic keys 12 may be configured to disable any alarming security device 14 following a security event. However, the host 24 may be configured to continue to transmit a security signal, such as until the security device 14 is re-armed. Moreover, disabling a security signal on the host 24 may not affect the armed status of the remaining security devices 14 in the store, i.e., the security devices may operate one-to-one in every regard except for generation of security signals. Of course, a variety of types of electronic keys 12 as disclosed herein, including leveraging a secure application available on a smartphone, tablet or PC.

[0074] In some embodiments, a pre-emptive disarm for purposes of remerchandising items of merchandise or nightly removal of the item from an associated security device 14 may be employed. For example, a computing device 26 of the retailer (e.g., a mobile device) 26 may be configured to automatically disarm one or more security devices 14 at a predetermined period of time. In some cases, a secure software application may permit a temporary suspension of alerts for a specific position of a security device 14 for a programmable period to permit re-merchandising. Once disarmed, the security device's transceiver will cease communicating until it is re-armed. For those customers operating in a "Non-IP Connected" mode can elect to silence the audible alarm of the security device 14 when remerchandising such that no audible alarm will sound, but the host may continue to generate a signal (e.g., light signal) until all security devices are re-armed.

[0075] As described herein, embodiments of the present invention may utilize a variety of wireless network configurations. In some cases, a common architecture would require two distinct network topologies. The first network may be a private wireless network for the exclusive use of the security devices 14 deployed instore. This network is separate from any private or public network operated by the retailer. The second network may be an IP Gateway between the private network and the Internet. This second network may be a connection on retailer's managed network or could be via a cellular modem. The gateway could be integrated into the host or be a separate device that connects to the host.

[0076] In some embodiments, the private network may be commonly used by all security devices 14 for internal data transfer and minimize frequency congestion for retailer managed networks. Moreover, in one example, the private network practically takes the form as a "star network" – with multiple individual nodes 20 performing individual functions and collecting and providing data. This data is wirelessly sent to and aggregated within a common "host". The host allows nodes 20 providing data wirelessly via the private network to deliver functionality and value to the customer independent of an Internet connection to a cloud-based application, such as alerting and reporting functionality. In one implementation, the host rather than the security device 14 would be configured to provide notification (e.g., in response to a security event) via audio, visual, and/or haptic response.

[0077] Various considerations may be taken into account regarding the private network. For instance, in selecting the appropriate, common network architecture for the private network, considerations of the size of the data packets and data rate required, the needed wireless range, potential for interference, power consumption, size, and/or cost of the network may be taken into account. In some applications, intermittent transmission of small data packets, with no need for higher data rates, may be used, which may benefit from a network with low power needs and long data range. Examples of private networks include various RF networks, such as Wi-Fi (2.4 GHz), Bluetooth (2.4 GHz) and Sub GHz (less than 1.0 GHz) ISM band

networks. Some network stacks (controlling software) such as Zigbee and LoRa can run on both sub GHz and 2.4 GHz networks.

[0078] Another example embodiment of a wireless network system includes various types of security devices 14 and electronic keys 12 that may cooperate with one or more nodes 20, hubs 24, and/or computing devices 26 in a wireless network (see, e.g., FIGS. 26-42). Various types of security devices 14 may be employed in the system, such as those disclosed herein. For example, security devices 14 that include a sensor that is configured to be attached to an item (e.g., via adhesive and/or brackets). In some implementations, the sensor may be connected to a base or stand 35 with a tether 45 (see, e.g., FIGS. 30-32), or no tether may be used in some cases (see, e.g., FIGS. 32-33). Sensors 25 may take many different forms, such as, for example, standalone sensors (see, e.g., FIG. 36), “chairback” sensors (see, e.g., FIG. 33), sensors that provide power and security for the item of merchandise (e.g., via USB-C, micro-USB, etc. connectors) (see, e.g., FIG. 35), and/or sensors that only provide security (e.g., a sensor including a plunger switch) (see, e.g., FIG. 34). Similarly, the base 35 used to removably support a sensor 25 may also take different forms (see, e.g., FIG. 33 where a chairback sensor is used with electrical contacts for transferring power between the sensor and the base). Of course, the security devices 14 may be used in various industries such as retail stores and for a variety of items, such as merchandise or commercial items (e.g., tablet computers).

[0079] As shown in FIGS. 27-29, various numbers and types of security devices 14 may be configured to communicate with one another in a network, such as a private wireless network as discussed above. A host or hub 24 may be configured to communicate with each of the plurality of security devices 14 in the network and provide various security signals, such as disclosed herein. An interface may be provided on the hub 24 for facilitating communication with an electronic key 12. FIG. 27 shows an example where the plurality of security devices 14 and hub 24 are configured to communicate in an IP network which may allow for various information and alerts to be provided to one or more computing devices 26 (e.g., system health, power status, alarm status, and/or inventory information). Moreover, FIG. 28 illustrates an example similar to FIG. 27 but where the system includes additional features via a SaaS subscription to enterprise software, such as for example, displaying planogram (“POG”) compliance information, consumer activity, programmable KPI’s, inventory re-stock thresholds, and/or inventory POG compliance. FIGS. 30-31 show various depictions of a plurality of security devices 14 in the form of a sensor and base which are configured to communicate with a hub 24 and a computing device 26 configured to receive notifications from the hub (e.g., no power at the security device or a breach has occurred). Furthermore, FIGS. 37-42 illustrate embodiments of security devices 14 in the form of locks that are configured to communicate in the wireless network with the hub 24. In these examples, a customer may be able to request assistance (e.g., via a call

button on the security device 14) that enables a sales associate to be notified and to thereafter engage the customer or control the security device 14 with an electronic key 12 or computing device 26. The retail associate could use an electronic key 12 to unlock the security device 14 for the customer (see, e.g., FIG. 38), or use a computing device 26 to unlock the security device. In some cases, the customer's mobile telephone may perform some of the functions disclosed herein ("Trusted Customer"), such as unlocking a security device 14 in response to receiving a wireless authorization signal (see, e.g., FIG. 39). For example, a Trusted Customer may be a customer who has purchased an item and is picking the item up in the store or one who has an account with the retailer and is purchasing the item using the customer's mobile device. In addition, various data may be collected regarding the security device 14, such as for example, the type of product that was removed from a cabinet or drawer protected by a lock, and allows for alerts to be provided to one or more computing devices 26 (see, e.g., FIG. 40). The security devices 14 may be configured to automatically relock after an authorized opening and accessing the item of merchandise (see, e.g., FIG. 41), and various techniques may be employed to track items of merchandise added or removed from a cabinet or drawer, such as an RFID scanner that is configured to scan the product as the item is added or removed from the cabinet or drawer (see, e.g., FIG. 42).

[0080] In other embodiments, inventory information may be obtained regarding merchandise on a security device 14 such as a locking hook, information may be obtained regarding items of merchandise removed from a security device (e.g., a cabinet), and computing devices 26 may be used to obtain various types of information and provide various types of commands for controlling the security device and/or item of merchandise. Embodiments of wireless systems disclosed herein may provide for real time reporting of Who/What/When/Where/Why/How for interactions with security devices 14 and items of merchandise, be responsive/interactive, migrate from security focus to omni-channel experience enablement within the retail store, facilitate Trusted Customer engagement with security assets, allow to readily customize and expand the system, enable alternative business models such as SaaS models, connect local network of connected assets with central hub for local computing, and/or connect hub to cloud platform for providing alerts, reporting, system administration, daily operation. Embodiments may also provide a platform infrastructure having a centralized hub per retail store and several fit for purpose connected end security device assets such as stands, sensors, table managers, locks, cabinet sensors, inventory sensors, customer dwell sensors, etc. that all communicate with the hub. Due to the flexibility of wireless systems in some embodiments, customers do not need to pre-select which security devices 14 to purchase since the platform infrastructure is common. Furthermore, computing devices 26 and mobile devices used by retailers may allow retailers and store associates to dynamically interact with security devices 14 to make real-time decisions, such as responding to security events, restocking out of stock inventory, or responding to customer requests for

assistance with secured items of merchandise.

[0081] In some cases, each electronic key 12 may be authorized for specific locations, departments, or merchandise security devices. For instance, FIG. 4 shows that a manager may have authorization for all zones, locations, departments, or merchandise security devices (indicated as numbers 1-6), while a first associate may only have authorization for two zones, locations, departments, or merchandise security devices (indicated as numbers 4 and 5), and a second associate may only have authorization for one zone, location, department, or merchandise security device (indicated as number 6). As such, a retail store or other establishment may limit the scope of authorization for different associates within the same retail store. In order to accommodate different authorizations levels, each key 12 may be configured to store a code that is associated with each zone, location, department, or merchandise security device. For example, each zone may include a plurality of merchandise security devices 14, and a retail store may have multiple zones (e.g., a zone for electronics, a zone for jewelry, etc.).

[0082] Various techniques may be used to initially program the electronic key 12. For example, the electronic key 12 may be initially presented to each authorized merchandise security device 14. Upon communication with the security device 14 or the cloud 22, the electronic key 12 will be paired with each security device. A programming station 16 may provide a code to the electronic key 12, and the key or cloud 22 may then communicate the code to each of its authorized security devices 14. Each key 12 may only need to be programmed once. In some embodiments, a programming station 16 may be located within each zone, and a key 12 may receive a code from each programming station that it is authorized. Thereafter, each key 12 may need to be “refreshed” at the programming station 16 or a charging station 18 following a predetermined period of time or in response to being disabled as described in various examples herein. In other embodiments, the electronic key 12 may be programmed directly via the cloud 22.

[0083] In another embodiment, each electronic key 12 may include a security code and a serial number for one or more merchandise security devices 14. For example, a key 12 may only be able to arm, disarm, lock, or unlock a merchandise security device 14 where the security codes and the serial numbers match one another. In one example, each serial number is unique to a merchandise security device 14 and could be programmed at the time of manufacture or by the retailer. This technique allows for greater flexibility in programming keys 12 and assigning keys to particular merchandise security devices 14 and/or zones. In one embodiment, a setup electronic key 12” may be used to initially map particular merchandise security devices 14 and serial numbers. In this regard, the setup key 12” may be used to communicate with each key 12 and obtain the serial number of each merchandise security device 14. The setup key 12” may also obtain a location of the security devices 14, or a user of the setup key may provide a description for each merchandise security device (e.g., SN # 123 = merchandise security device #1). The setup key 12” may

communicate with a tablet or other computing device 26 for accumulating all of the information (see, e.g., FIGS. 3 and 19), which may occur via wired or wireless communication. Thus, the tablet or computing device 26 may map each of the serial numbers with the merchandise security devices 14 and in some cases, may also include serial numbers and corresponding electronic keys 12. Individual electronic keys 12 may then be assigned particular serial numbers for authorized merchandise security devices 14 (e.g., user 1 includes serial numbers 1, 2, 3; user 2 includes serial numbers 1, 4, 5). Each of the electronic keys 12 may be programmed with the same security code using a programming station 16. In some embodiments, the setup process may be used in conjunction with a planogram of the merchandise security devices 14. The planogram may represent a layout of the merchandise security devices 14 within a retail store or other establishment. For example, a setup key 12” may be used to map serial numbers to specific merchandise security devices 14 on a planogram as the setup key communicates with each merchandise security device. The setup key 12” may communicate with a tablet or other computing device 26 for populating the planogram with serial numbers, such as via a wired connection (see, e.g., FIG. 19). This planogram may be uploaded to a remote location or device for managing the planogram and ensuring planogram compliance based on information exchanged between the security devices 14 and the computing device 26. As before, particular serial numbers may be assigned to authorized users.

[0084] In order to arm, disarm, lock, or unlock a merchandise security device 14, the electronic key 12 may communicate with a particular merchandise security device and determine whether the security codes and the serial numbers match. If the codes match, the electronic key 12 then arms, disarms, locks, or unlocks the merchandise security device 14. Upon refreshing an electronic key 12 and/or when a user requests an electronic key via programming or authorization station 16, any available electronic key may be used since the key may be programmed in real time with the appropriate level of authorization for that user (e.g., specific zones, departments, and/or merchandise security devices).

[0085] In one embodiment, the merchandise display security system 10 comprises an electronic key 12 and a merchandise security device 14 that is configured to be operated by the key. The system may further comprise an optional programming station 16 that is operable for programming the key 12 with a security code, which may also be referred to herein as a Security Disarm Code (SDC). In addition to programming station 16, the system may further comprise an optional charging station 18 that is operable for initially charging and/or subsequently recharging a power source disposed within the key 12. For example, the key 12 and merchandise security device 14 may each be programmed with the same SDC into a respective permanent memory. The key 12 may be provisioned with a single-use (i.e., non-rechargeable) power source, such as a conventional or extended-life battery, or alternatively, the key may be provisioned with a multiple-use (i.e. rechargeable) power source, such as a conventional capacitor or rechargeable

battery. In either instance, the power source may be permanent, semi-permanent (i.e., replaceable), or rechargeable, as desired. In the latter instance, charging station 18 is provided to initially charge and/or to subsequently recharge the power source provided within the key 12. Furthermore, key 12 and/or merchandise security device 14 may be provided with only a transient memory, such that the SDC must be programmed (or reprogrammed) at predetermined time intervals. In this instance, programming station 16 is provided to initially program and/or to subsequently reprogram the SDC into the key 12. As will be described, key 12 may be operable to initially program and/or to subsequently reprogram the merchandise security device 14 with the SDC. Key 12 is then further operable to operate the merchandise security device 14 by transferring power and/or data to the device, as will be described.

[0086] In the exemplary embodiment of the system illustrated in FIGS. 1-2, electronic key 12 is configured to be programmed with a unique SDC by the programming station 16. In some embodiments, the key 12 is presented to the programming station 16 and communication therebetween is initiated, for example, by pressing or otherwise actuating a control button 28 provided on the exterior of the key. Communication between the programming station 16 and the key 12 may be accomplished directly, for example by one or more electrical contacts, or indirectly, for example by wireless communication. Any form of wireless communication capable of transferring data between the programming station 16 and key 12 is also possible, including without limitation optical transmission, acoustic transmission or magnetic induction. In some embodiments shown and described herein, communication between programming station 16 and key 12 is accomplished by wireless optical transmission, and more particularly, by cooperating infrared (IR) transceivers provided in the programming station and the key. In some embodiments, the programming station 16 may function similarly to that disclosed in United States Patent No. 7,737,844 entitled PROGRAMMING STATION FOR A SECURITY SYSTEM FOR PROTECTING MERCHANDISE, the disclosure of which is incorporated herein by reference in its entirety. For the purpose of describing some embodiments of the present invention, it is sufficient that the programming station comprises at least a logic control circuit for generating or being provided with a SDC, a memory for storing the SDC, and a communications system suitable for interacting with the electronic key 12 in the manner described herein to program the key with the SDC.

[0087] An available feature of a merchandise security system 10 according to one embodiment is that the electronic key 12 may include a time-out function. More particularly, the ability of the key 12 to transfer data and/or power to the merchandise security device 14 may be deactivated after a predetermined time period. By way of example, the electronic key 12 may be deactivated after about six to about twenty-four hours from the time the key was programmed or last refreshed. In this manner, an authorized sales associate typically must program or refresh the key 12 assigned to him at the beginning of each work shift.

Furthermore, the charging station 18 may be configured to deactivate the electronic key 12 when the key is positioned within or otherwise engaged with a charging port 30 (see, e.g., FIG. 1). In this manner, the charging station 18 can be made available to an authorized sales associate. In one embodiment, the electronic key 12 may be authorized upon the sales associate inputting an authorized code to release the key for use. For instance, the sales associate may input a code on a keypad in communication with the charging station 18. Upon inputting the correct code, the charging station 18 may indicate which key 12 is authorized for use by the sales associate (e.g., via an audible and/or a visible indicator). In some cases, the time-out period may be predetermined or customized by a user. For example, a manager of a retail store may input a particular time period for one or more of the electronic keys 12. Those electronic keys 12 that are “active” may be monitored via communication within the cloud-based network. In other embodiments, the electronic key 12 may be timed out or otherwise disabled in response to an event. For instance, the electronic key 12 may be disabled in response to the key being misplaced or stolen, or keys being brought into a retail store that are not authorized for use. Such disabling may alternatively occur via a command from a device 26 sent to the electronic key 12 via the cloud 22. In other cases, the electronic key 12 may be disabled in response to failure to communicate with the network (e.g., at a particular time or time interval), a lost connection to the network, and/or an inability to reconnect to the network. In another example, the electronic key 12 may be disabled in response to its memory being full, e.g., with audit data.

[0088] In one embodiment, commands may be provided remotely for taking various actions. For example, where a theft has occurred, a command may be provided from a remote location or device 26 (e.g., a tablet or computer) to lock and/or arm all or a portion of the merchandise security devices 14. Similarly, a command may be provided from a remote location or device 26 to deactivate all or a portion of the electronic keys 12 and/or security devices 14. As such, the system 10 provides techniques for centralized security and control of the electronic keys 12, merchandise security devices 14, and other components within the system. As discussed above, the electronic keys 12 may also be controlled remotely. Furthermore, in some embodiments, such requests or commands may be made by the computing device 26 for individual security devices 14 or a plurality of security devices (e.g., sending a command to lock all security devices in response to a security event). Moreover, one or more of the security devices 14 may be configured to lock or alarm in response to a security event (e.g., automatically locking a sensor attached to an item of merchandise to a base removably supporting the sensor).

[0089] FIGS. 5-6 illustrate one embodiment of an electronic key 12. The electronic key 12 may include a control button 28 for activating the key, such as for initiating communication with a merchandise security device. Moreover, the electronic key 12 may also include one or more visual indicators. In this regard, the key 12 may include one or more status indicators 32 that illustrate a status of the communication

of the key with a merchandise security device 14. The status indicators 32 may guide the user to know when communication between the key 12 and the merchandise security device 14 is taking place and has been completed. The status indicators 32 may be different depending on whether the communication was authorized (e.g., unlocked or disarmed), unauthorized (e.g., wrong zone or department), or unsuccessful. The status indicators 32 may also indicate an amount of time of authorized use remaining on the key 12, such as where the key includes a time-out feature as discussed above. The electronic key 12 may also include one or more other indicators 34 that provide a visual indication of the power remaining on the key. These other indicators 34 may also be used for any other desired purpose, such as to indicate a programming state of the key 12. For example, the indicators 34 may be activated while the electronic key 12 is being initially programmed. It is understood that the illustrated status indicators 32, 34 are for illustration only, as various types and configurations of indicators may be employed in alternative embodiments.

[0090] FIGS. 7-10 illustrate additional embodiments of electronic keys 12. In these examples, the electronic key 12 includes a removable portion 36. In FIGS. 7-8, the removable portion 36 allows access to an input power port 38, such as for recharging the electronic key 12. The removable portion 36 may be configured to slide relative to the electronic key 12 to expose the input power port 38. The input port 38 may be configured to receive and electrically connect to a corresponding connector, such as a connector associated with the charging station 18. For instance, the electronic key 12 may be configured to be docked within the charging station 18 for charging thereof (see, e.g., FIG. 1). As shown in FIGS. 9-10, the removable portion 36 may also be configured to be removed entirely from the electronic key 12 and may be multi-purpose in that it may include a tool portion 40. For example, the tool portion 40 may be used for facilitating the disconnection of various connectors, as a screwdriver, etc. The electronic key 12 may include an opening 42 defined to receive the removable portion 36 therein in a non-use position.

[0091] FIGS. 20-21 show additional embodiments of an electronic key 12'. In this embodiment, the electronic key 12' includes one or more alignment features 15 for facilitating alignment with a programming or authorization station 16' and/or a charging station 18' as discussed in further detail below. In addition, the electronic key 12' includes an input port 17 (e.g., a micro-USB port) which may be configured to releasably engage a corresponding port on the programming or authorization station 16' and/or the charging station 18' for data and/or power transfer. Notably in the example shown in FIG. 20, the input port 17 on the electronic key 12' is on a side surface, while a pair of alignment features 15 are provided on opposite surfaces of the electronic key. In the embodiment shown in FIG. 21, a single alignment feature 15 is provided. The input port 17 may be located on a side surface between a transfer port at one end and a key chain ring opening at an opposite end. Positioning of the input port 17 on a side surface of the electronic key 12' may provide for a more secure and stable attachment to the programming or authorization station

16' and/or the charging station 18'. A series of status indicators 32, 34, as discussed above, for example light-emitting diodes (LEDs) may be provided on the exterior of the electronic key 12' for indicating the operating status thereof.

[0092] As shown in FIG. 1, the programming station 16 comprises a housing configured to contain the logic control circuit that generates the SDC, the memory that stores the SDC, and a communications system for communicating the SDC to the key (e.g., wirelessly). In use, the logic control circuit generates the SDC, which may be a predetermined (i.e. "factory preset") security code, a manually input security code, or a security code that is randomly generated by the logic control circuit. In the latter instance, the logic control circuit further comprises a random number generator for producing the unique SDC. A series of visual indicators, for example light-emitting diodes (LEDs) may be provided on the exterior of the housing for indicating the operating status of the programming station 16. Programming station 16 may further be provided with an access mechanism for preventing use of the programming station by an unauthorized person. For example, the programming station may include a keypad 44. An authorized user may input a code in the key pad 44 that allows the programming station 16 to generate a SDC for communicating to the key 12.

[0093] In a particular embodiment, the logic control circuit of the programming station 16 performs an electronic exchange of data with a logic control circuit of the key, commonly referred to as a "handshake communication protocol." The handshake communication protocol determines whether the key 12 is an authorized key that has not been programmed previously (e.g., a "new" key), or is an authorized key that is being presented to the programming station 16 a subsequent time to refresh the SDC. In the event that the handshake communication protocol fails, the programming station 16 will not provide the SDC to the unauthorized device attempting to obtain the SDC. When the handshake communication protocol succeeds, programming station 16 permits the SDC to be transmitted by the key 12. As will be readily apparent to those skilled in the art, the SDC may be transmitted from the programming station 16 to the key 12 by any suitable means, including without limitation, wireless, electrical contacts or electromechanical, electromagnetic or magnetic conductors, as desired. Moreover, in other cases the programming station 16 may simply provide the SDC to the electronic key 12 without first initiating any handshake communication protocol.

[0094] In some embodiments, the merchandise security device 14 is a "passive" device. As used herein, the term passive is intended to mean that the security device 14 does not have an internal power source sufficient to lock and/or unlock a mechanical lock mechanism. Significant cost savings are obtained by a retailer when the merchandise security device 14 is passive since the expense of an internal power source is confined to the key 12, and one such key is able to operate multiple security devices. If desired,

the merchandise security device 14 may also be provided with a temporary power source (e.g., capacitor or limited-life battery) having sufficient power to activate an alarm, for example a piezoelectric audible alarm, that is actuated by a sensor, for example a contact, proximity or limit switch, in response to a security breach. The temporary power source may also be sufficient to communicate data, for example a SDC, from the merchandise security device 14 to the key 12 to authenticate the security device and thereby authorize the key to provide power to the security device. In other cases, the security device may be an electronic device, such as a sensor attached to the item of merchandise and a base that removably supports the sensor thereon. The sensor may be attached to the base with a tether or may be wireless (e.g., using ranging techniques as described in more detail below).

[0095] In some embodiments, the merchandise security device 14 further comprises a logic control circuit, similar to the logic control circuit disposed within the key 12, adapted to perform a handshake communication protocol with the logic control circuit of the key in essentially the same manner as that between the programming station 16 and the key. In essence, the logic control circuit of the key 12 and the logic control circuit of the merchandise security device 14 communicate with each other to determine whether the merchandise security device is an authorized device that does not have a security code, or is a device having a matching SDC. In the event the handshake communication protocol fails (e.g., the device is not authorized or the device has a non-matching SDC), the key 12 will not program the device with the SDC, and consequently, the merchandise security device will not operate. If the merchandise security device 14 was previously programmed with a different SDC, the device will no longer communicate with the key 12. In the event the handshake communication protocol is successful, the key 12 permits the SDC stored in the key to be transmitted to the merchandise security device 14 to program the device with the SDC. As will be readily apparent to those skilled in the art, the SDC may be transmitted from the key 12 to the merchandise security device 14 by any suitable means, including without limitation, via radiofrequency, one or more electrical contacts, electromechanical, electromagnetic or magnetic conductors, as desired. Furthermore, the SDC may be transmitted by inductive transfer of data from the electronic key 12 to the merchandise security device 14. Moreover, in other cases the electronic key 12 may simply provide the SDC to the merchandise security device 14 without first initiating any handshake communication protocol.

[0096] In one embodiment, when the handshake communication protocol is successful and the merchandise security device 14 is an authorized device having the matching SDC, the merchandise security device may be armed or disarmed, such as where the security device includes an alarm circuit. In other embodiments, the merchandise security device 14 may be armed or disarmed when the SDC codes match. In some embodiments, when the handshake communication protocol is successful and the SDC codes

match, the logic control circuit of the key 12 causes an internal power source of the key to transfer electrical power to the device 14 to operate a mechanical lock mechanism. In other embodiments, the merchandise security device 14 may be locked or unlocked when the SDC codes match and power is transferred to the merchandise security device. It is understood that various information and codes may be exchanged in order to perform the desired function, such as arming, disarming, locking, or unlocking the merchandise security device 14. For example, the data exchanged may include a serial number of the merchandise security device alone and/or an SDC.

[0097] FIG. 11 shows one embodiment of a merchandise security device 140 in greater detail. As previously mentioned, the merchandise security device 14 can be any type of security device that utilizes an alarm circuit and/or a lock mechanism that locks and/or unlocks a lock. In some cases, the merchandise security device 140 may be a passive device in the sense that it does not have an internal power source sufficient to operate a lock mechanism. As a result, the merchandise security device 140 may be configured to receive power, or alternatively, both power and data, from an external source, such as the electronic key 12 shown and described herein. The embodiment of the merchandise security device depicted in FIG. 11 is a cabinet lock configured to be securely affixed to the locking arm 104 of a conventional cabinet lock bracket 105. As previously described, the cabinet lock 140 may include a logic control circuit for performing a handshake communication protocol with the logic control circuit of the key 12 and for receiving the SDC from the key. In other embodiments, the cabinet lock 140 may be configured to transmit the SDC to the key 12 to authenticate the security device and thereby authorize the key to transfer power to the security device.

[0098] FIG. 12 shows an embodiment of an electronic key 120 with inductive transfer in greater detail. As previously mentioned, the key 120 may be configured to transfer both data and power to a merchandise security device 140. Accordingly, the programmable electronic key 120 may be an active device in the sense that it has an internal power source sufficient to operate a mechanical lock mechanism of the merchandise security device 140. As a result, the programmable electronic key 120 may be configured to transfer both data and power from an internal source, such as a logic control circuit (e.g., data) and a battery (e.g., power) disposed within the key. The embodiment of the programmable electronic key 120 depicted herein is a key with inductive transfer capability configured to be received within a transfer port 142 of the cabinet lock 140 shown in FIG. 11, as well as a programming port 46 of the programming station and the charging port 30 of the charging station. Thus, the electronic key 120 may be placed proximate to or within the transfer port 142 for communicating therewith. In some embodiments, a tag (e.g., RFID or NFC tag) as discussed above, may be positioned within the transfer port, or otherwise on the security device 140, so that the electronic key 120 is configured to read or otherwise obtain identification data from the tag.

[0099] In some embodiments, the electronic key 120 comprises a housing 121 having an internal cavity or compartment that contains the internal components of the key, including without limitation the logic control circuit, memory, communication system and battery, as will be described. As shown, the housing 121 is formed by a lower portion 123 and an upper portion 124 that are joined together after assembly, for example by ultrasonic welding. The electronic key 120 further defines an opening 128 at one end for coupling the key to a key chain ring, lanyard or the like. The electronic key 120 may further comprise a transfer probe 125 located at an end of the housing 121 opposite the opening 128 for transferring data and/or power to the merchandise security device 140. The transfer probe 125 is also operable to transmit and receive a handshake communication protocol and the SDC from the programming station 16, as previously described, and to receive power from a charging station.

[00100] As best shown in FIG. 13, an internal battery 131 and a logic control circuit, or printed circuit board (PCB) 132 are disposed within the housing 121 of the electronic key 120. Battery 131 may be a conventional extended-life replaceable battery or a rechargeable battery suitable for use with the charging station 18. The logic control circuit 132 is operatively coupled and electrically connected to a switch 133 that is actuated by the control button 122 provided on the exterior of the key 120 through the housing 121. Control button 122 in conjunction with switch 133 controls certain operations of the logic control circuit 132, and in particular, transmission of the data and/or power. In that regard, the logic control circuit 132 is further operatively coupled and electrically connected to a communication system 134 for transferring data and/or power. In one embodiment, the communication system 134 is a wireless infrared (IR) transceiver for optical transmission of data between the electronic key 120 and the programming station, and between the key and the merchandise security device 140. As a result, the transfer probe 125 of the key 120 may be provided with an optically transparent or translucent filter window 135 for emitting and collecting optical transmissions between the key 120 and the programming station 16, or between the key and the merchandise security device 140, as required. Transfer probe 125 may further comprise an inductive core 127 and inductive core windings 129 for transferring electrical power to the merchandise security device 140 and/or receiving electrical power from the charging station 18 to charge the internal battery 131, as required. Alternatively, the optical transceiver 134 may be eliminated and data transferred between the programmable electronic key 120 and the merchandise security device 140 via magnetic induction through the inductive coil 126.

[00101] In some embodiments, an important aspect of an electronic key 120, especially when used for use in conjunction with a merchandise security device 140 as described herein, is that the key does not require a physical force to be exerted by a user on the key to operate the mechanical lock mechanism of the merchandise security device. By extension, no physical force is exerted by the key 120 on the mechanical

lock mechanism. As a result, the key 120 cannot be unintentionally broken off in the lock, as often occurs with conventional mechanical key and lock mechanisms. Furthermore, neither the key 120 nor the mechanical lock mechanism suffer from excessive wear as likewise often occurs with conventional mechanical key and lock mechanisms. In addition, in some cases there is no required orientation of the transfer probe 125 of the electronic key 120 relative to the ports on any one of the programming station, charging station, and/or the merchandise security device 140. Accordingly, any wear of the electrical contacts on the transfer probe 125 and ports may be minimized. As a further advantage in some embodiments, an authorized person is not required to position the transfer probe 125 of the electronic key 120 in a particular orientation relative to the transfer port 142 of the merchandise security device 140 and thereafter exert a compressive and/or torsional force on the key to operate the mechanical lock mechanism of the device.

[00102] FIGS. 22-24 illustrate an embodiment of a programming or authorization station 16'. As illustrated, the programming or authorization station 16' includes a geometry for receiving the electronic key 12' as discussed above (see, e.g., FIG. 21). In this regard, the programming or authorization station 16' may include one or more alignment features 15' configured to align with and engage alignment feature 15 of the electronic key 12'. Moreover, the programming or authorization station 16' may further define a recess 48 for at least partially receiving a side surface of the electronic key 12'. The recess 48 may be curved or any other shape for corresponding to the shape of the electronic key 12'. Within the recess 48, the programming or authorization station 16' may include a port 30' for releasably engaging the input port 17 of the electronic key 12'. The alignment features 15, 15' are configured to align with one another to ensure that the input port 17 and port 30' align with and engage one another. Such engagement may allow for data communication between the electronic key 12' and the programming or authorization station 16', which may occur in some cases, upon entry of an authorized code using keypad 44. In addition, the programming or authorization station 16' may include one or more input ports 50 for receiving power and data communication (e.g., an Ethernet port).

[00103] FIG. 1 shows a charging station 18 in greater detail. As previously mentioned, the charging station 18 recharges the internal battery 131 of the key 12. In certain instances, the charging station 18 also deactivates the data transfer and/or power transfer capability of the key 12 until the key has been reprogrammed with the SDC by the programming station 16 or the user provides an authorized code to the charging station. Regardless, the charging station 18 comprises a housing for containing the internal components of the charging station. The exterior of the housing has at least one, and preferably, a plurality of charging ports 30 formed therein that are sized and shaped to receive the electronic key 12 (see, e.g., FIG. 1). Mechanical or magnetic means may be provided for properly positioning and securely retaining

the key 12 within the charging port 18 for ensuring proper power transfer.

[00104] FIGS. 16-18 show an embodiment of a charging station 18 wherein a plurality of ports 30 are provided for engagement with a plurality of corresponding electronic keys 12'. The electronic key 12' shown in FIG. 21 may be compatible with the charging station 18 shown in FIGS. 16-18 whereby the electronic key 12' includes an input port 17 on its side for engagement with the port 30, similar to that described in conjunction with programming or authorization station 16'. Likewise, each port 30 may be located within a respective recess 48 for receiving at least a side surface of the electronic key 12'. This arrangement may allow for a greater number of electronic keys 12' to be engaged with the charging station 18 at any one time.

[00105] FIGS. 14-15 show additional embodiments of a merchandise security device 150. In this embodiment, the merchandise security device 150 comprises a lock mechanism that utilizes "energy harvesting". Thus, the merchandise security device 150 may be a passive device as described above. However, in this embodiment, the merchandise security device 150 includes means for generating power to be stored. For example, the merchandise security device 150 may be configured to rotate between locked and unlocked positions and include a generator configured to generate energy to be stored (e.g., via a capacitor). In some cases, the merchandise security device 150 may include a bezel and each turn of the bezel may generate an electrical charge to be stored. In one embodiment, the electronic key 12 may be used initially to disengage a mechanical lock, and then the merchandise security device 150 may be rotated to an unlocked position. The merchandise security device 150 may then be rotated back to the locked position. Since the merchandise security device 150 has no power source, the security device is capable of performing various security functions using the stored power. For instance, the merchandise security device 150 may be configured to use the stored power to push data to one or more nodes 20 or to generate audible and/or visible signals. In one example, the merchandise security device 150 may include an internal radio for transmitting wireless signals using the stored power, such as for generating a distress signal when the security device is tampered with. In another example, the merchandise security device 150 may include a light-emitting device (LED) that is powered by the stored power.

[00106] In another embodiment, a plurality of nodes are employed for peer-to-peer communication to facilitate the generation of an alarm signal, such as audible and/or visible signals. For example, FIG. 25 shows a plurality of merchandise security devices 14 (e.g., sensors) and alarm nodes 30 configured to wirelessly communicate various information to a gateway 24 via a network. For example, the sensors 14 and/or nodes 30 may be configured to send information to and receive information from the gateway 24 regarding their configuration, alarm status (e.g., alarming, armed, disarmed), and/or instructions (e.g., arm, alarm, or disarm). The merchandise security devices 14 and nodes 30 may also be configured to

communicate directly with one another as described below, as well as to switch between communication with the gateway 24 and one another. Any number of nodes 30 could be located at various positions within a retail store, for example, such as on a display table or store entrance or exit. The nodes 30 may communicate wirelessly with merchandise security devices 14 and a gateway 24 within a network, such as described above using various wireless communication protocols. One disadvantage of using wireless communication to initiate the alarm at a location that is remote from the merchandise security device 14 is that the alarm signals often have to travel to a wireless hub where a server then deciphers the data and decides to send out an alarm signal to the appropriate alarm node. This kind of system may create latency in generating the alarm signal, particularly if the server is not local, and if any component of the wireless chain of communication is interrupted (e.g., the hub loses power), the alarm signal may never reach the alarm node and thus no alarm occurs. In one embodiment, multiple modes of communication may be used to reduce or eliminate these issues. For example, in addition to a first wireless communication protocol between the merchandise security devices 14 and gateway 24 and/or alarm nodes 30 and the gateway (e.g., WiFi, LoRa, etc.), a second wireless communication protocol may be used that is a direct node-to-node communication scheme between the merchandise security devices and the alarm nodes that does not have to also communicate with any hub or gateway. The communication protocols could be the same or different in some embodiments. In one example, the second wireless communication protocol could be performed using the same radio antennas that the other operational signals are communicated with the hub or gateway 24 (e.g., Wi-Fi, LoRa, etc.), which thereby adds no additional cost or size to either the merchandise security devices 14 and the alarm nodes 30 in order to accomplish the communication. However, a second radio is also an option. Additionally, the alarm signal could be broadcast on a different frequency than the other signals in order to address regional regulatory requirements and/or if it is detected or known that certain frequency bands are getting congested. This communication could be two-way, but one-way communication would be sufficient in most circumstances. The merchandise security device 14 may send out a “help me” signal in response to a security event. The alarm node 30 would then only have to “listen” for that signal and if it receives the signal, the alarm node may generate an alarm by whatever means it is programmed for (e.g., light, sound, vibration, etc.).

[00107] In some instances, a plurality of alarm nodes 30 may be used, and particular merchandise security device(s) 14 may be configured to activate specific alarm node(s). For example, in the instance where a retail store includes a plurality of display tables for a plurality of merchandise security devices 14, there may be an alarm node 30 associated with each table which would only be triggered by a “help me” signal from any one of the merchandise security devices associated with the same table. In this situation, an identifier (e.g., an ID code) could be added to the “help me” signal that corresponds to a code stored in

the alarm node 30. Thus, the alarm node 30 may have to receive or identify its code in order to generate an alarm signal. This could be as simple as the code itself being the “help me” signal or some other instruction code could be added to or included with the identifier, for example, if more than one action (e.g., “alarm” or “stop alarming”) needed to be communicated to the alarm node. The merchandise security device 14 may be configured to generate this “help me” signal immediately upon a breach and only after sending the signal to the alarm node 30, would the merchandise security device then communicate via the wireless communication to a hub and gateway that a breach has occurred. Thus, the latency delay should be minimized in such a breach scenario.

[00108] As discussed above, electronic keys 12, 120 and computing devices 26 may be configured to communicate and/or control various security devices 14. FIG. 43 illustrates embodiments of a merchandise display security system 200 include locks 202 used for locking various types of fixtures 205, such as cabinets and drawers. In the examples shown in FIGS. 43 and 47, locks 202 may be used to secure sliding glass doors and drawers (see also FIGS. 48-49). The system 10 may include various wireless functionality for communication between the locks 202, computing devices 26, hubs or gateways, electronic keys 12, 120, and/or remote devices. For instance, FIG. 44 illustrates that a retail store may include wireless communication circuitry in the form of a wireless router or other like hub 24 may facilitate Wi-Fi communication, although other forms of communication could be used such as cellular. The hub 24 may be used to facilitate communication between the computing devices 26 and one or more remote devices. In some cases, the electronic keys 120 may be configured to communicate with the one or more remote devices as well via the hub 24. Communication between the computing devices 26 and one or more remote devices may be used to assigning authorization to the various computing devices and/or communicating various types of data such as the types of data disclosed above. For example, data may include lock status and system health information.

[00109] Computing devices 26 may include wireless communications circuitry configured for BLE, Bluetooth, and/or NFC communication. The computing devices 26 may also or alternatively include a camera or a scanner for scanning images or information from the locks 202 as discussed in further detail below. Similarly, the locks 202 may include various wireless communications circuitry configured for BLE, Bluetooth, and/or NFC communication. The locks 202 may also or alternatively include a barcode or other identifier. In some cases, the computing devices 26 may be configured to be paired with one or more locks 202 (e.g., via Bluetooth communication) and/or include one or more additional communication protocols for operating the lock (e.g., NFC, camera, barcode, etc.).

[00110] In one example embodiment, the computing devices 26 are configured to communicate with one or more locks 202 using a first communication protocol (e.g., Bluetooth). In order to unlock a specific

lock, the computing device 26 may further be configured to communicate with each lock using a second communication protocol (e.g., NFC or image scanning). The second communication protocol may be used to identify a specific lock 202 that the computing device 26 is authorized to unlock. For instance, an NFC tag may have an identifier that is unique to the lock 202 (similar to a serial number), and if the computing device 26 confirms that the identifiers match, then the computing device is authorized to unlock the lock. If the computing device 26 is authorized based on confirmation of identification of the lock 202, the computing device may then communicate an unlock command to the lock using the first communication protocol.

[00111] In some cases, the locks 202 are configured to transmit signals continuously or nearly continuously, such as via Bluetooth beaconing. The computing device 26 may be configured to automatically detect the signals transmitted by the locks 202, and the user may then use the computing device to communicate with the lock via a second communication protocol to identify the lock to be unlocked (e.g., via NFC). Once the lock 202 has been identified, the user may then be able to direct the computing device 26 to send an unlock command to the lock 202. The computing device 26 may be configured to communicate with the lock 202 using the first communication protocol after identifying the lock using the second communication protocol. For instance, the lock 202 may be configured to send a beacon signal in predetermined intervals that includes an identification of the lock, and after the lock has been identified by the computing device 26, the computing device and lock may establish communication upon receiving the next beacon signal.

[00112] The locks 202 may take many different forms and configurations. The locks 202 may include various types of lock assemblies for different applications, such a plunger lock for sliding cabinet doors or a cam lock for drawers. FIGS. 45A-C show one embodiment of a lock 202, where the lock includes a lock mechanism 212, a drive mechanism 214, an NFC tag 216, a transfer port 206 with an IR transceiver, an inductive coil 218, a PCBA 220 with a Bluetooth module, and an internal power source 222 (e.g., batteries). Moreover, FIGS. 46A-B show that the locks 202 may have different shapes depending on the application. For instance, some locks 202 may or may not include an internal power source 222, thereby affecting the size of the lock. In some applications, the internal power source 222 may be external to the lock 202, such as for a drawer where the lock may be positioned on the front of the drawer and the internal power source may be positioned inside the drawer and in electrical communication with the lock. In one embodiment further illustrated in FIGS. 50A-B, the lock 202 may include an NFC tag 216 and a transfer port 206, where the transfer port is similar to that described above for communication with an electronic key 12, 120. The NFC tag 216 may be positioned behind a cover 208 that masks or otherwise conceals the NFC tag. For instance, the cover may be plastic with a spun metal effect. In another example, the lock 202 may include

a 2D barcode 210. The lock 202 may include a removable cover 208 that is configured to conceal the NFC tag 216, barcode 210, or like identifier and to be removed for communication with a computing device 26. In some embodiments, the locks 202 may include features such as that disclosed in U.S. Provisional Application Nos. 63/194,301, 63/194,239, and 63/194,347, each entitled MERCHANDISE DISPLAY SECURITY SYSTEMS AND METHODS, the entire disclosures of which are incorporated herein by reference in their entirety.

[00113] As noted above, the lock 202 may be configured to communicate with an electronic key 120 for unlocking the lock. FIG. 51 shows an example of a key 120 communicating with the lock 202 via the transfer port 206. The key 120 may be used in addition or alternatively to using a computing device 26 to unlock the lock. In the instance where the power source 222 of the lock 202 is no longer capable of unlocking the lock (e.g., the batteries are depleted), the key 120 may be configured to transfer power to the lock for operating the lock, as disclosed above. In another embodiment, FIGS. 52A-B show that the internal power source 222 may be a modular component 224 such that the power source may be replaced with another power source, such as in the form of a removable battery pack having a housing containing one or more batteries. In other cases, the modular component 224 (e.g., removable battery pack) may be removed and replaced with a cover if the internal power source is no longer needed or the lock is being used for a different application. Thus, embodiments of the present invention enable operation of the locks 202 even if the internal power source 222 is incapable of unlocking the lock.

[00114] In some embodiments, the modularity of the power source 222 (e.g., battery pack) may be dependent or independent of the operation of the lock 202. In this regard, theft of the power source 222 may be problematic if it hinders the operation of the lock 202. In one example, the locking mechanism used to unlock the lock 202 may be dependent on a mechanism for accessing the internal power source 222. Thus, a user would need to use a computing device 26 or electronic key 120 to access the internal power source 222. The lock 202 may be required to be in an unlocked state before the internal power source 222 may be accessed thereby requiring an authorized user to be present before being able to access the internal power source. In other embodiments, a second lock mechanism that is independent of the locking mechanism of the lock 202 may be employed for accessing the internal power source 222. The second lock mechanism may be configured to be operated by a computing device 26, electronic key 120, and/or other type of key. For example, a mechanical lock mechanism may be operable using a magnetic key or tool configured to unlock the lock mechanism for releasing or accessing the internal power source 222. In some cases, different user access levels may be used such that only certain users are authorized to unlock the second lock mechanism for accessing the internal power source 222 (e.g., a manager may be assigned access privileges for such access but a retail associate is not). Such access levels could be used when assigning

access privileges as disclosed above.

[00115] In operation, FIG. 53A shows an example of a user using a computing device 26 to unlock a lock using NFC communication where the user places the computing device in close proximity to the NFC tag 216 which results in automatically unlocking the lock. FIGS. 53B-C also show that a user may use a camera 226 or scanner 228 of a computing device 26 to scan a barcode 210 for unlocking the lock. In some cases, consumers or store associates may use the camera 226 of the computing device 26 to unlock the lock 202, whereas only a store associate may be authorized to use a scanner 228 of a computing device 26. The computing device 26 may include a software application that facilitates communication with the locks 202 in any of the above examples, such as by allowing a user to select an “unlock” command for unlocking the lock 202 if the user is authorized to do so. Authorization may be accomplished in various ways, such as via the embodiments described above (e.g., assignment of particular locks or zones). In other cases, the user may be authorized by virtue of being pre-authorized by downloading the software application and entering various information for identifying the user. The software application may also be password protected for ensuring the user is authorized to operate the lock 202. In addition, the software application may facilitate data collection and communication to one or more remote devices.

[00116] In some embodiments, the user may be required to manually unlatch the lock 202 after using a computing device 26 or electronic key 120 to unlock the lock. For instance, the lock mechanism 212 may be configured to be unlocked using a computing device 26, and the user may be required to actuate a drive mechanism 214 to effectuate unlatching. Following a successful unlock command from a computing device 26, FIG. 54A shows that the user may have a limited or pre-determined amount of time in which to unlatch the lock 202. For instance, the lock 202 may include a visible indicator 230 (e.g., an LED) that illuminates or flashes different colors or frequencies depending on whether the lock 202 is capable of being unlatched or not. If the user chooses to unlatch the lock 202 after a successful unlocking command, the lock may be configured to be manually unlatched during the permitted access time, such as by rotating or pulling a portion of the lock (see, e.g., FIG. 54B). For example, if the lock 202 is a cam style lock, the user may be able to rotate a knob for unlatching the lock, whereas if the lock is a plunger style lock, the user may be able to pull the knob for unlatching the lock. The lock 202 may be configured to automatically relock itself after a predetermined period time. Moreover, the user may be required to manually relatch the lock 202, such as after the permitted access time has expired (see, e.g., FIG. 54C). In some cases, the user may be required to rotate or push the knob of the lock 202 in an opposite direction to relatch that was used to unlatch the lock. If the user prematurely relatches the lock 202, the user may be required to first unlock the lock the lock to again relatch the lock when the fixture is in its fully closed position. It is understood that the lock 202 may include various actuators for unlatching the lock, such as knobs, handles, etc. that may be

used to manually unlatch and relatch the lock. In other embodiments, a separate latching operation may be omitted, such as where the user is able to open the door without having to unlatch a latch mechanism.

[00117] As discussed above, the locks 202 may be used in any number of applications. In one example, the locks 202 may be placed on fixture 205 (e.g., a cabinet) for securing objects therein, such as an item that has been purchased by a consumer. For instance, the consumer may be configured to access the purchased item using his or her computing device 26 after making a purchase online. Thus, upon arriving at a retail store, the consumer may be able to present the computing device 26 to the lock 202 for accessing the purchased item. Along a similar rationale, the lock 202 may be used in applications such as an automotive center or facility where a consumer has had his or her vehicle serviced. In this embodiment, a consumer leaves his or her keys with the service provider so that the required service may be performed on the vehicle. Upon completion of the service, the consumer may be able to retrieve his or her keys using a computing device 26. In this way, a consumer may be able to complete the purchase using the computing device 26 and access his or her keys upon authorized access to the lock 202. Each consumer's keys may be locked within a respective enclosure within the fixture 205. Authorized access may be granted in a variety of ways, such as any of the techniques discussed above regarding communication between a lock 202 and the computing device 26. In other cases, the consumer may be prompted to input a code at the lock 202 to access his or her keys (e.g., via pin code), wherein the code may be provided to the consumer upon completing the purchase of the service. Thus, in some cases, the consumer's computing device 26 is not required. In other cases, an associate may be able to assist the consumer with retrieving the consumer's keys, such as by using a computing device 26 or electronic key 120. Thus, the lock 202 may secure the consumer's keys until the service provider grants access to the secure enclosure housing the consumer's keys. Clearly, this paradigm could be applied to other products and services where a consumer is able to retrieve a product or an item and/or an associate is able to assist a consumer in doing so.

[00118] It should be noted that the operations in instructions executed by the security devices, computing devices, and electronic keys for any of the embodiments disclosed herein may be provided by a computer-readable medium, memory, or other storage medium (e.g., a software application or product). The foregoing has described one or more exemplary embodiments of a merchandise display security system. Embodiments of a merchandise display security system have been shown and described herein for purposes of illustrating and enabling one of ordinary skill in the art to make, use and practice the invention. Those of ordinary skill in the art, however, will readily understand and appreciate that numerous variations and modifications of the invention may be made without departing from the spirit and scope thereof. Accordingly, all such variations and modifications are intended to be encompassed by the appended claims.

That which is claimed is:

1. A security system comprising:
a plurality of locks configured to protect one or more items from theft, each of the plurality of locks configured to wirelessly communicate with one or more mobile computing devices;
wherein each of the plurality of locks is configured to establish communication with one or more of the mobile computing devices using a first communication protocol,
wherein each of the plurality of locks is configured to subsequently communicate with one or more of the mobile computing devices using a second communication protocol, different than the first communication protocol, for identifying one or more of the plurality of locks to be unlocked, and
wherein the one or more of the plurality of locks identified by the one or more mobile computing devices is configured to be unlocked in response to subsequently communicating with the one or more of the plurality of locks using the first communication protocol.
2. The security system of Claim 1, further comprising a plurality of electronic keys configured to wirelessly communicate with one or more of the plurality of locks for unlocking the locks using a third communication protocol different than the first and second communication protocols.
3. The security system of Claim 2, wherein the third communication protocol is magnetic induction.
4. The security system of Claim 2, wherein the third communication protocol is infrared communication.
5. The security system of Claim 2, wherein the plurality of electronic keys are configured to obtain data from each of the locks.
6. The security system of Claim 2, wherein at least one of the plurality of electronic keys is configured to be authorized for unlocking one or more different locks than at least one other electronic key.
7. The security system of Claim 2, wherein each of the plurality of electronic keys is configured to transfer power to each of the locks for unlocking the locks.
8. The security system of Claim 1, wherein the plurality of mobile computing devices are configured to obtain data from each of the plurality of locks and to communicate the data to the one or more remote devices using a third communication protocol, different than the first and second communication protocols.
9. The security system of Claim 1, wherein the items are items of merchandise located in a retail store.
10. The security system of Claim 1, wherein the plurality of locks comprise different types.

11. The security system of Claim 1, wherein at least one of the plurality of mobile computing devices is configured to be authorized for unlocking one or more different locks than at least one other mobile computing device.
12. The security system of Claim 1, wherein the mobile computing device is a mobile telephone.
13. The security system of Claim 1, wherein the plurality of locks do not have an internal power source.
14. The security system of Claim 1, wherein each of the plurality of locks include an internal power source.
15. The security system of Claim 14, wherein the internal power source is modular and configured to be attached and detached from the lock.
16. The security system of Claim 15, wherein the internal power source is configured to be detached in response to communication with one of the mobile computing devices.
17. The security system of Claim 15, wherein the internal power source is configured to be detached in response to communication with a key.
18. The security system of Claim 1, wherein the first communication protocol is Bluetooth communication.
19. The security system of Claim 1, wherein the second communication protocol is NFC.
20. The security system of Claim 1, wherein each of the plurality of locks comprises a latch configured to be manually actuated by a user for unlatching the lock following unlocking of the lock.
21. The security system of Claim 20, wherein each of the plurality of locks comprises an actuator for unlatching the locks.
22. The security system of Claim 1, wherein each of the plurality of locks is configured to continuously beacon a signal using the first communication protocol.
23. The security system of Claim 22, wherein the signal comprises an identification of the lock.
24. The security system of Claim 1, further comprising a hub configured to facilitate wireless communication between the plurality of mobile computing devices and one or more remote devices using a third communication protocol that is different than both the first and second communication protocols.
25. The security system of Claim 24, wherein the hub is configured to communicate with the mobile computing devices via a cloud network.
26. The security system of Claim 1, further comprising any combination of features recited by any of Claims 1-25.

27. A method for protecting items from theft, the method comprising:
establishing communication between each of a plurality of locks and one or more mobile computing devices using a first communication protocol, each of the plurality of locks configured to protect one or more items from theft;
subsequently communicating between one or more of the plurality of locks and one or more of the mobile computing devices using a second communication protocol, different than the first communication protocol, for identifying one or more of the plurality of locks to be unlocked, and
unlocking the one or more of the plurality of locks identified by the one or more mobile computing devices in response to subsequently communicating with the one or more of the plurality of locks using the first communication protocol.
28. The method of Claim 27, further comprising communicating between one or more of the plurality of locks and one or more electronic keys for unlocking the locks using a third communication protocol different than the first and second communication protocols.
29. The method of Claim 27, further comprising determining whether a user is authorized to unlock the one or more of the plurality of locks identified by the one or more computing devices.
30. The method of Claim 27, wherein unlocking comprises receiving an unlock command from the one or more computing devices.
31. The method of Claim 27, further comprising any combination of features recited by any of Claims 27-30.
32. A security system comprising:
a plurality of locks configured to protect one or more items from theft, each of the plurality of locks configured to wirelessly communicate with one or more mobile computing devices; and
a plurality of electronic keys configured to communicate with one or more of the plurality of locks for unlocking the locks,
wherein each of the plurality of locks is configured to establish communication with one or more of the mobile computing devices using a first communication protocol,
wherein each of the plurality of locks is configured to subsequently communicate with one or more of the mobile computing devices using a second communication protocol, different than the first communication protocol, for identifying one or more of the plurality of locks to be unlocked,
wherein the one or more of the plurality of locks identified by the one or more mobile computing devices is configured to be unlocked in response to subsequently communicating with the one or more of the plurality of locks using the first communication protocol, and
wherein each of the plurality of electronic keys is configured to communicate with each of the

plurality of locks using a third communication protocol different than the first and second communication protocols.

33. A system, method, and/or computer program medium comprising any combination of features disclosed herein.

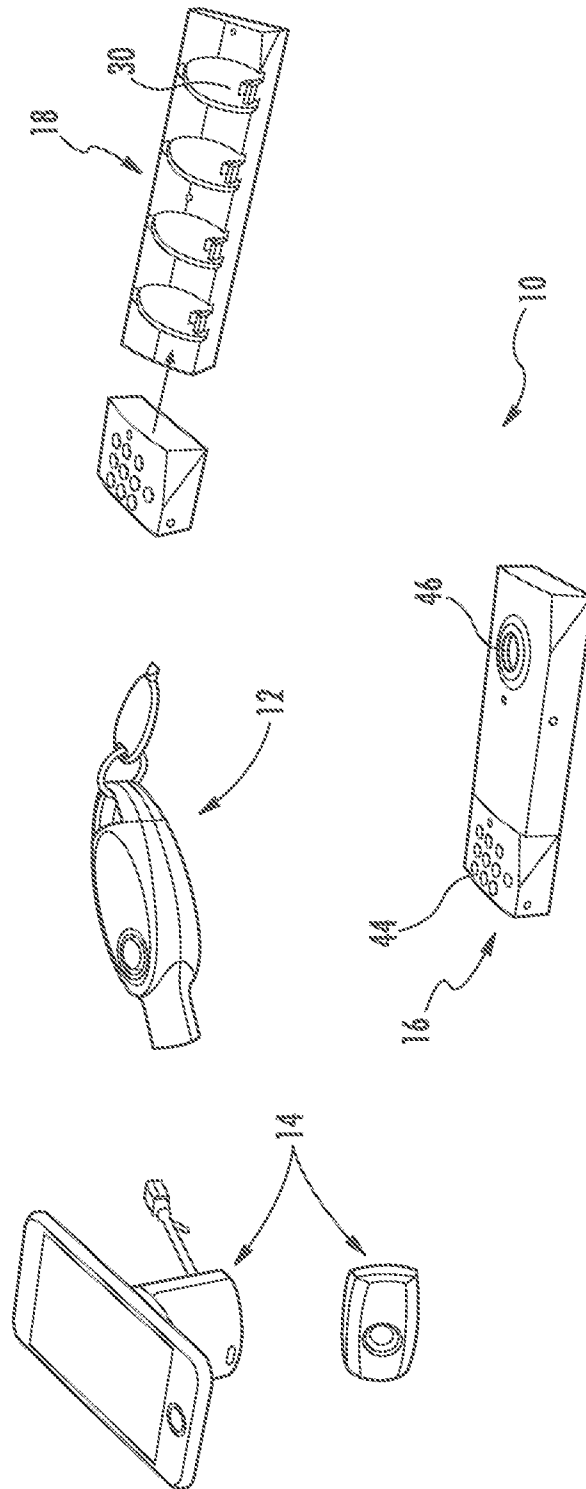

FIG. 1

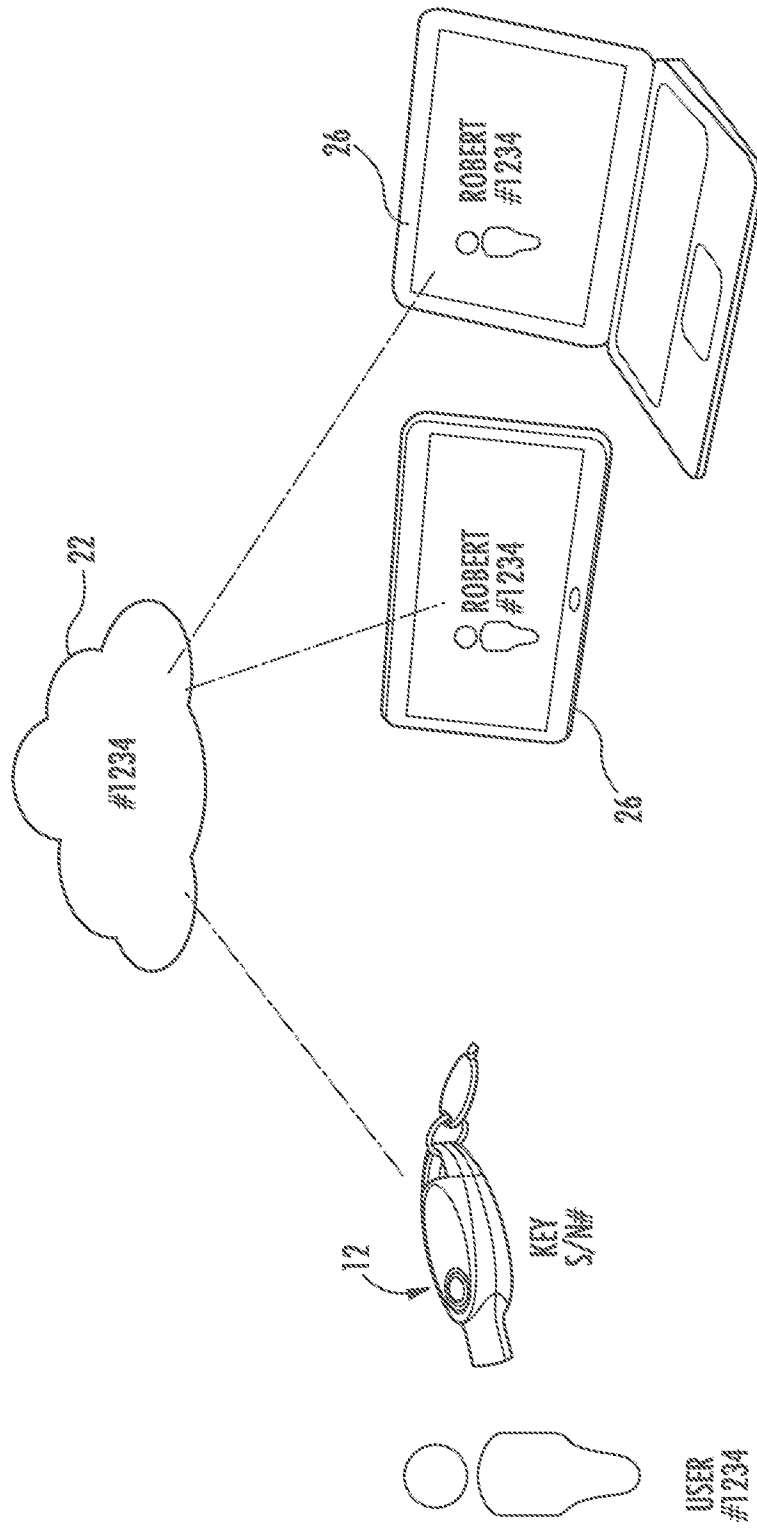

FIG. 3

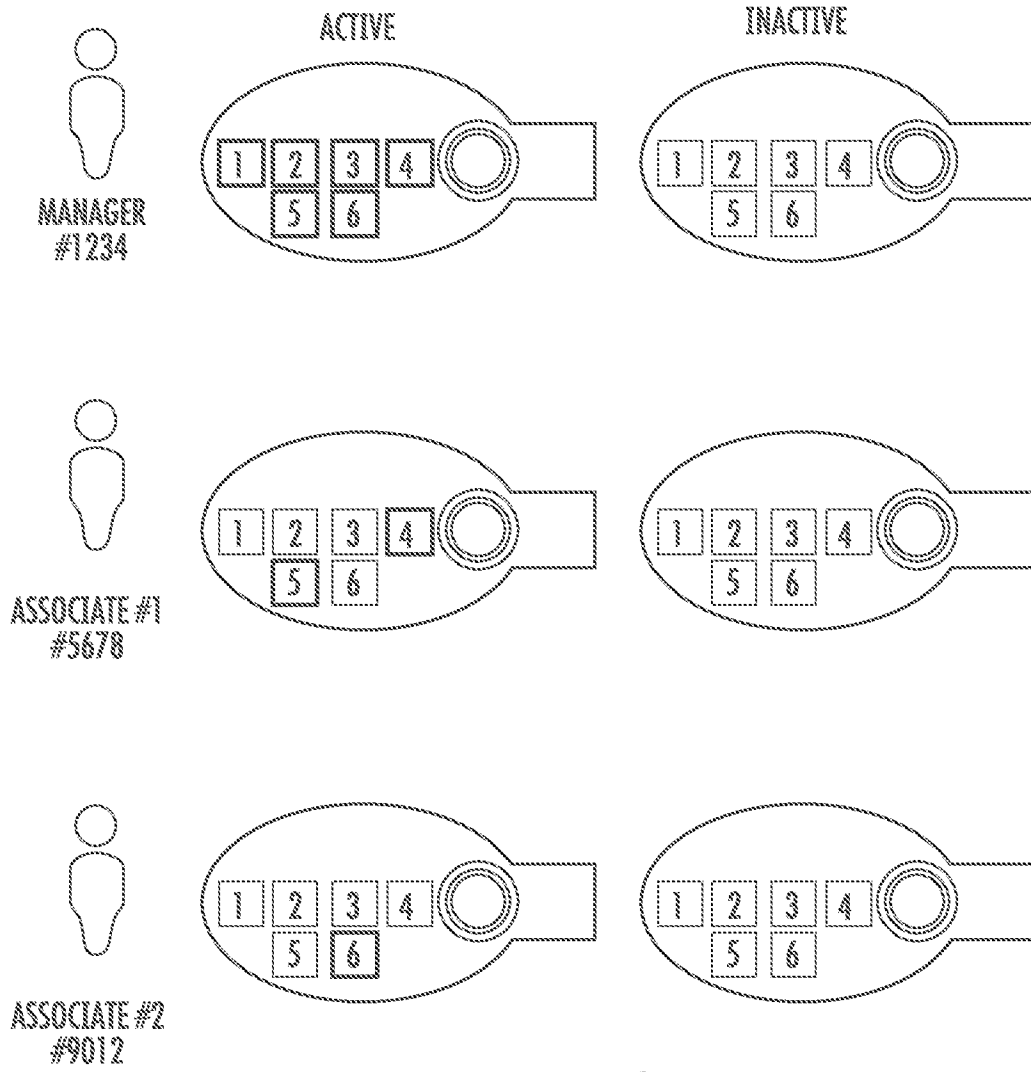

FIG. 4

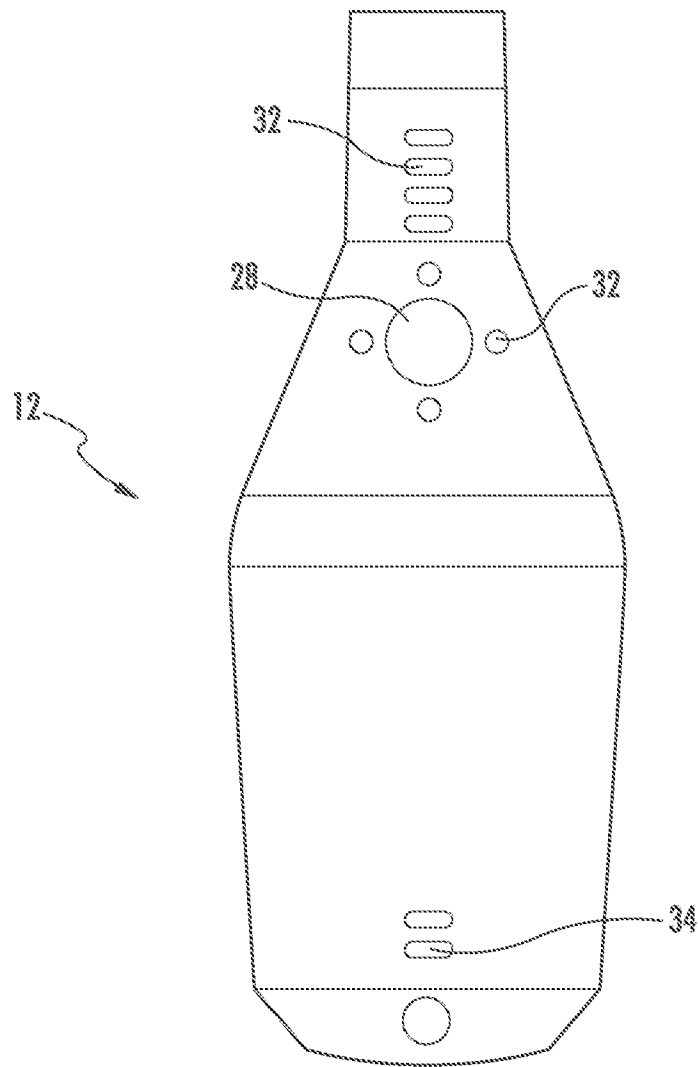

FIG. 5

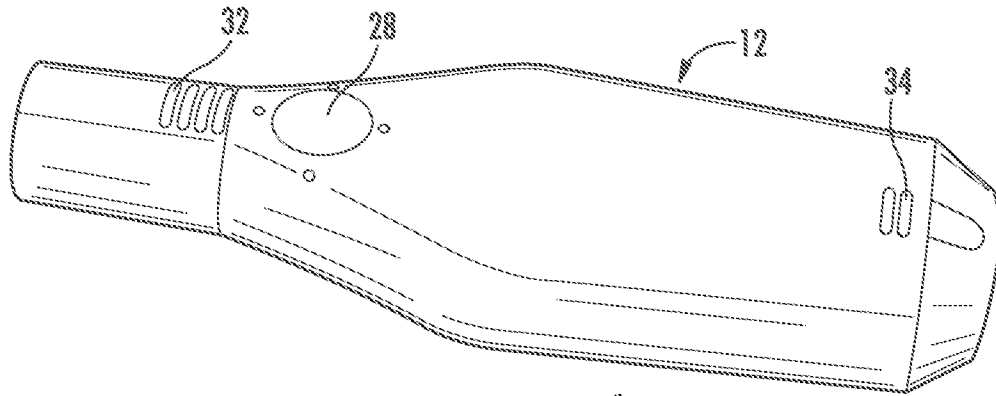

FIG. 6

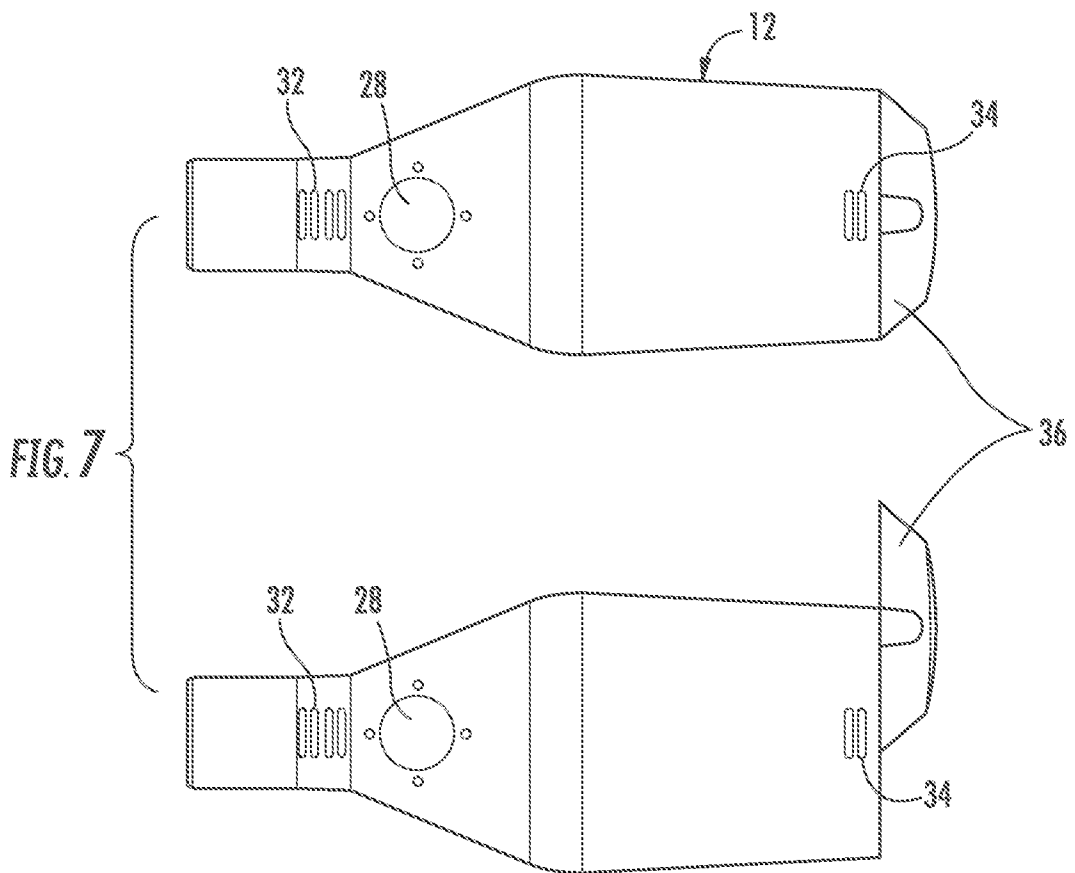

FIG. 7

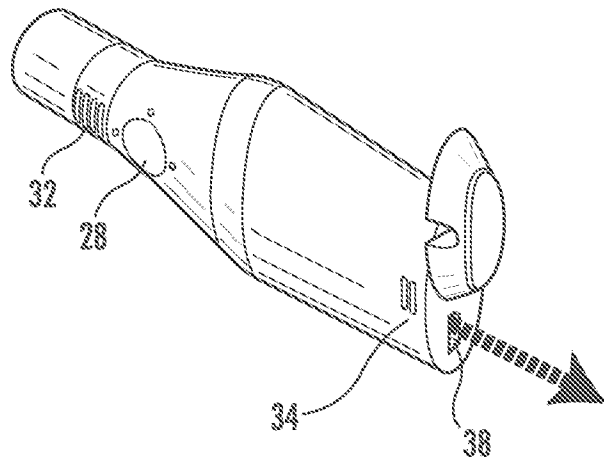

FIG. 8

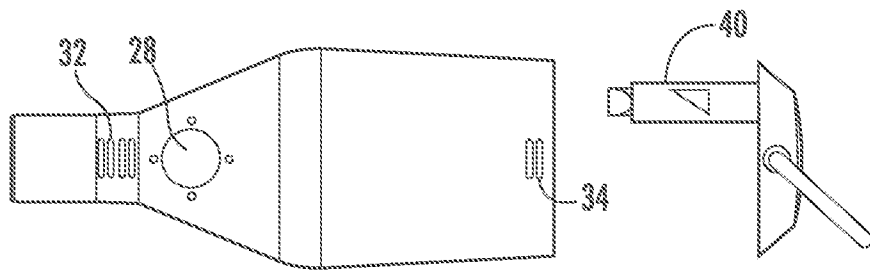

FIG. 9

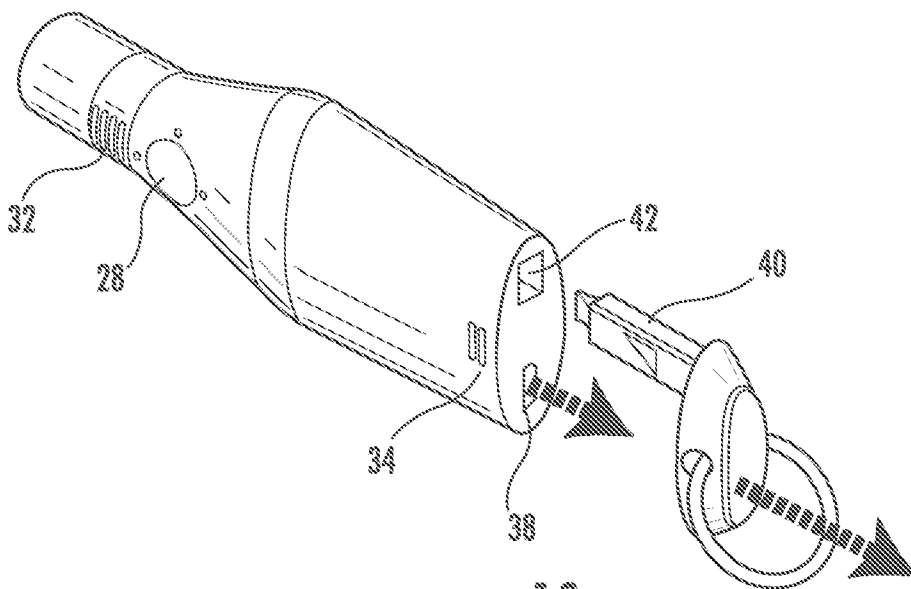

FIG. 10

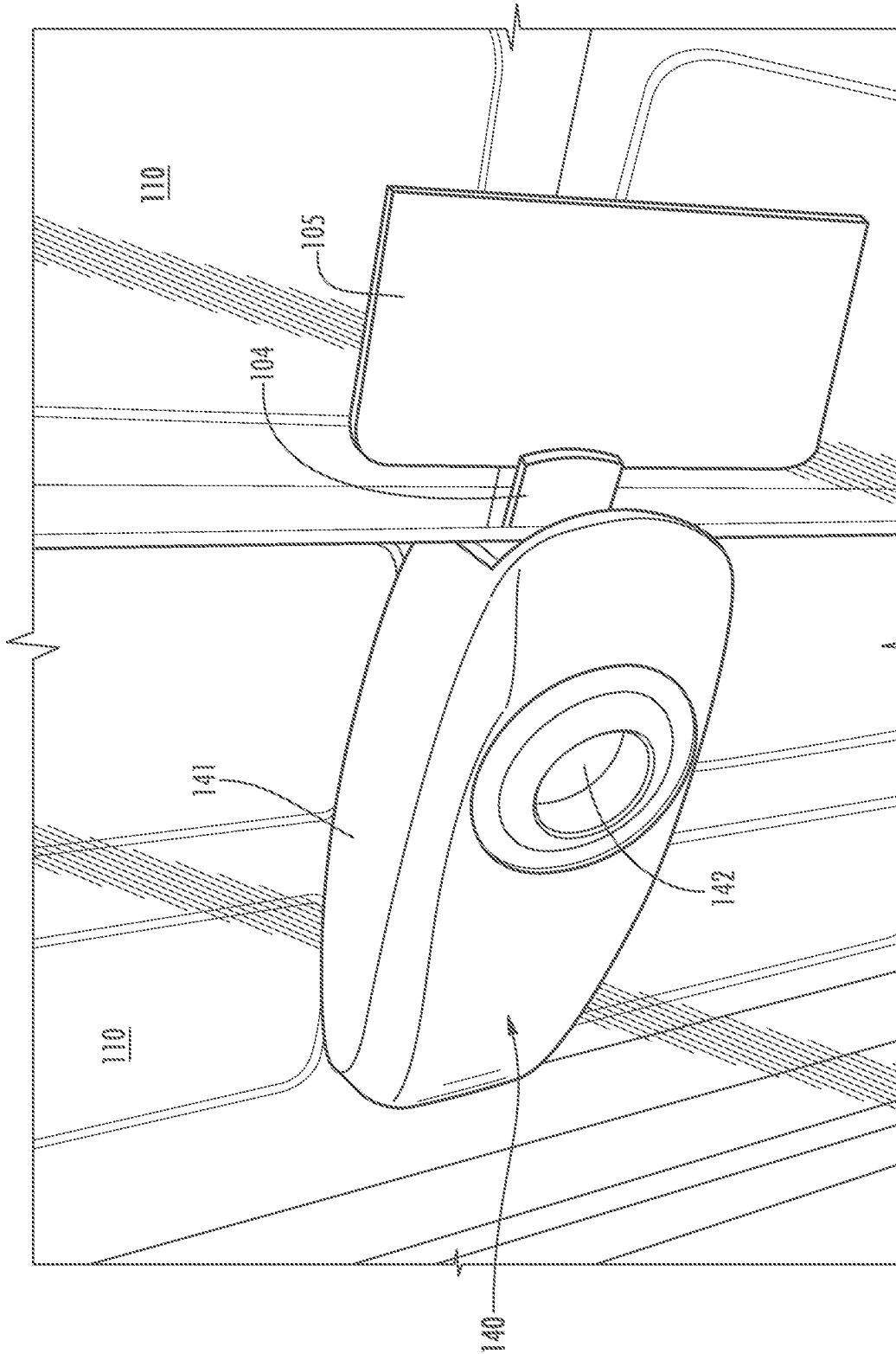

FIG. 11

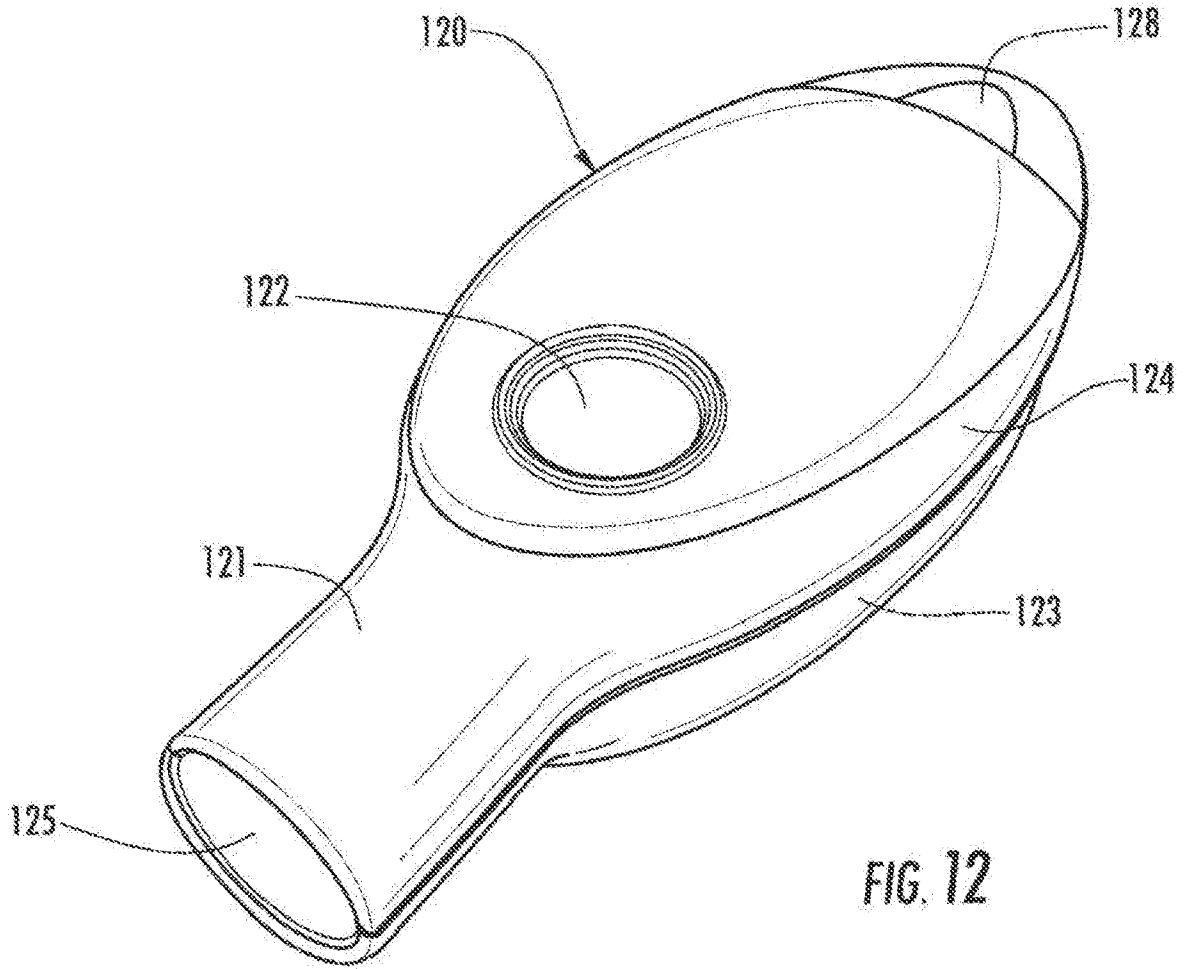

FIG. 12

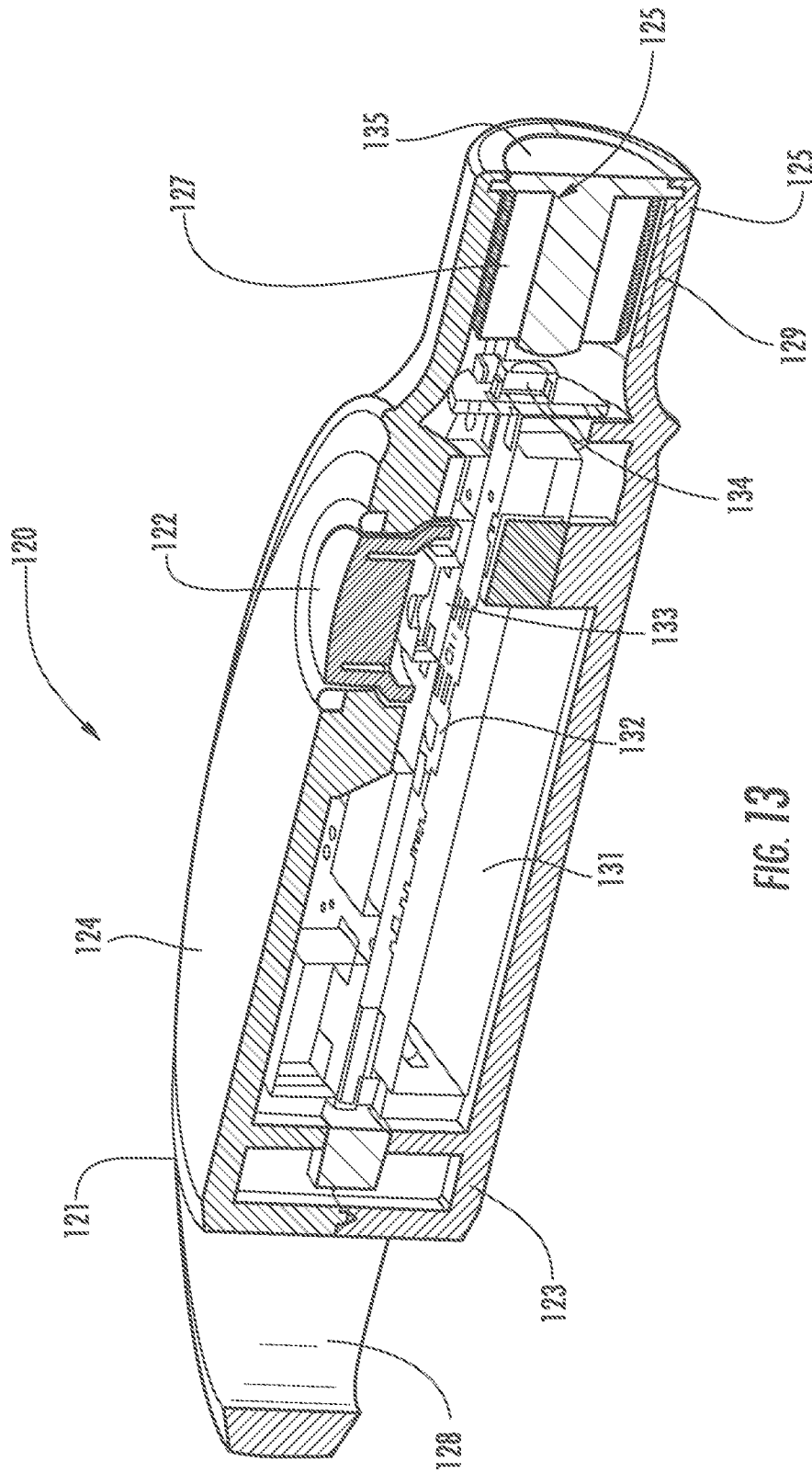

FIG. 13

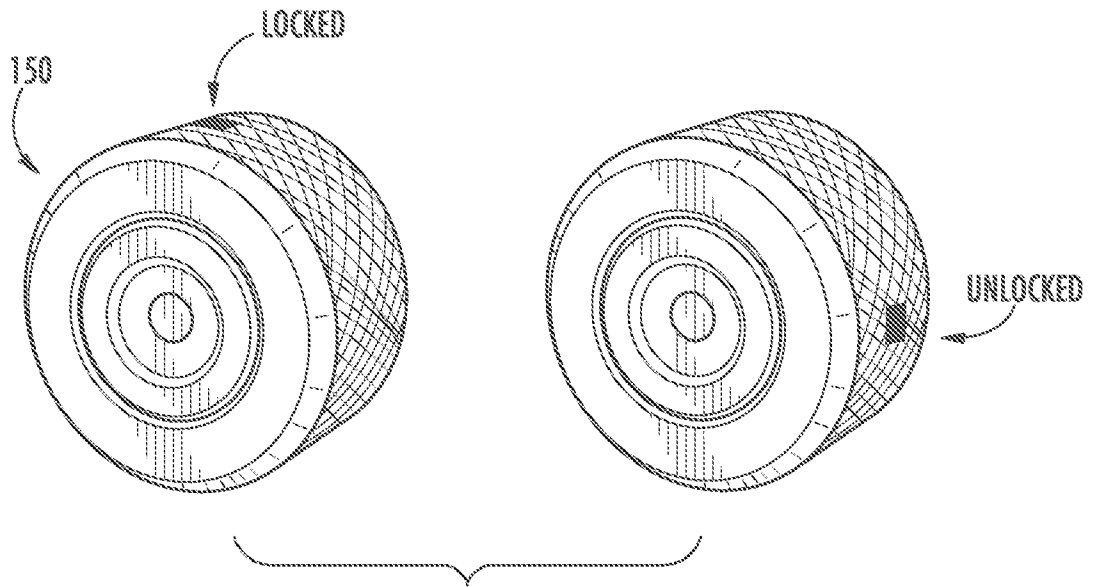

FIG. 14

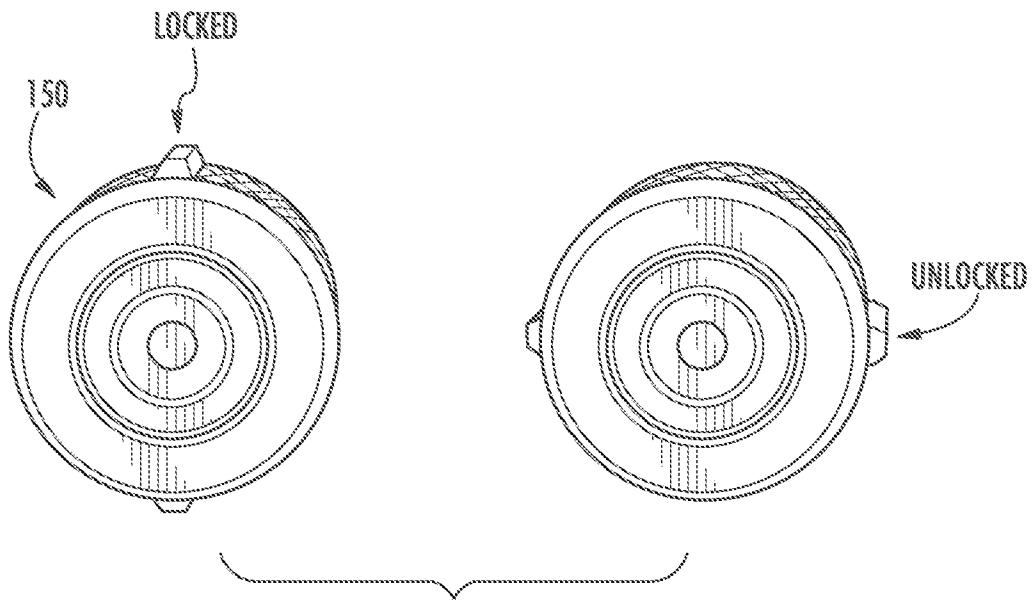

FIG. 15

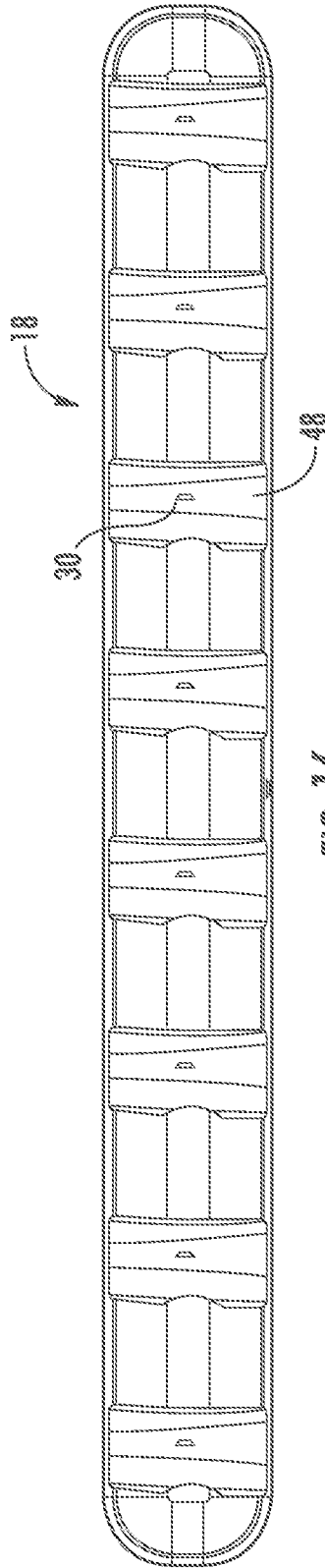
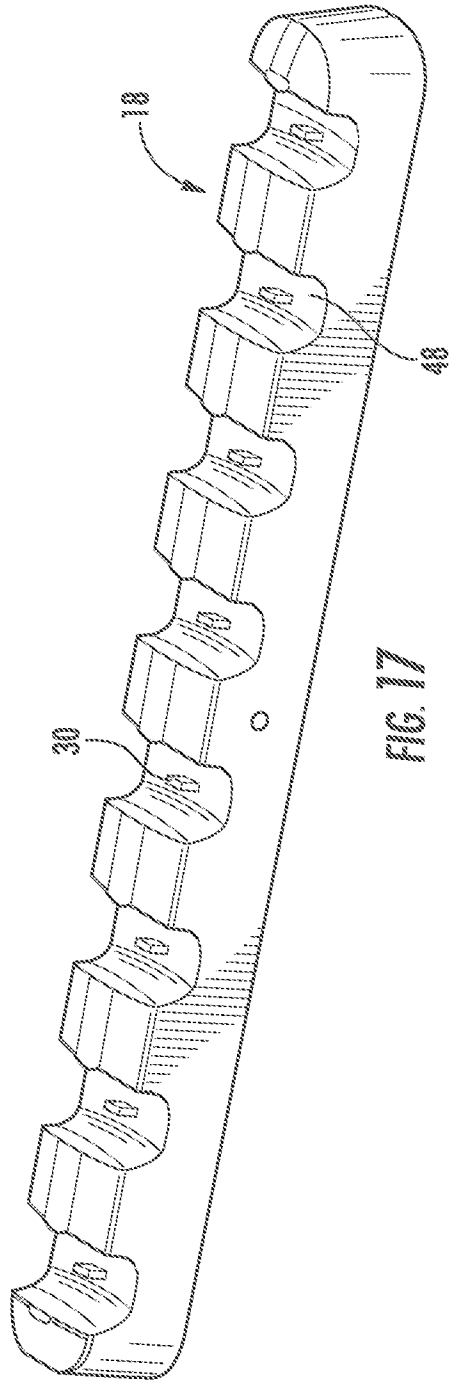

FIG. 16



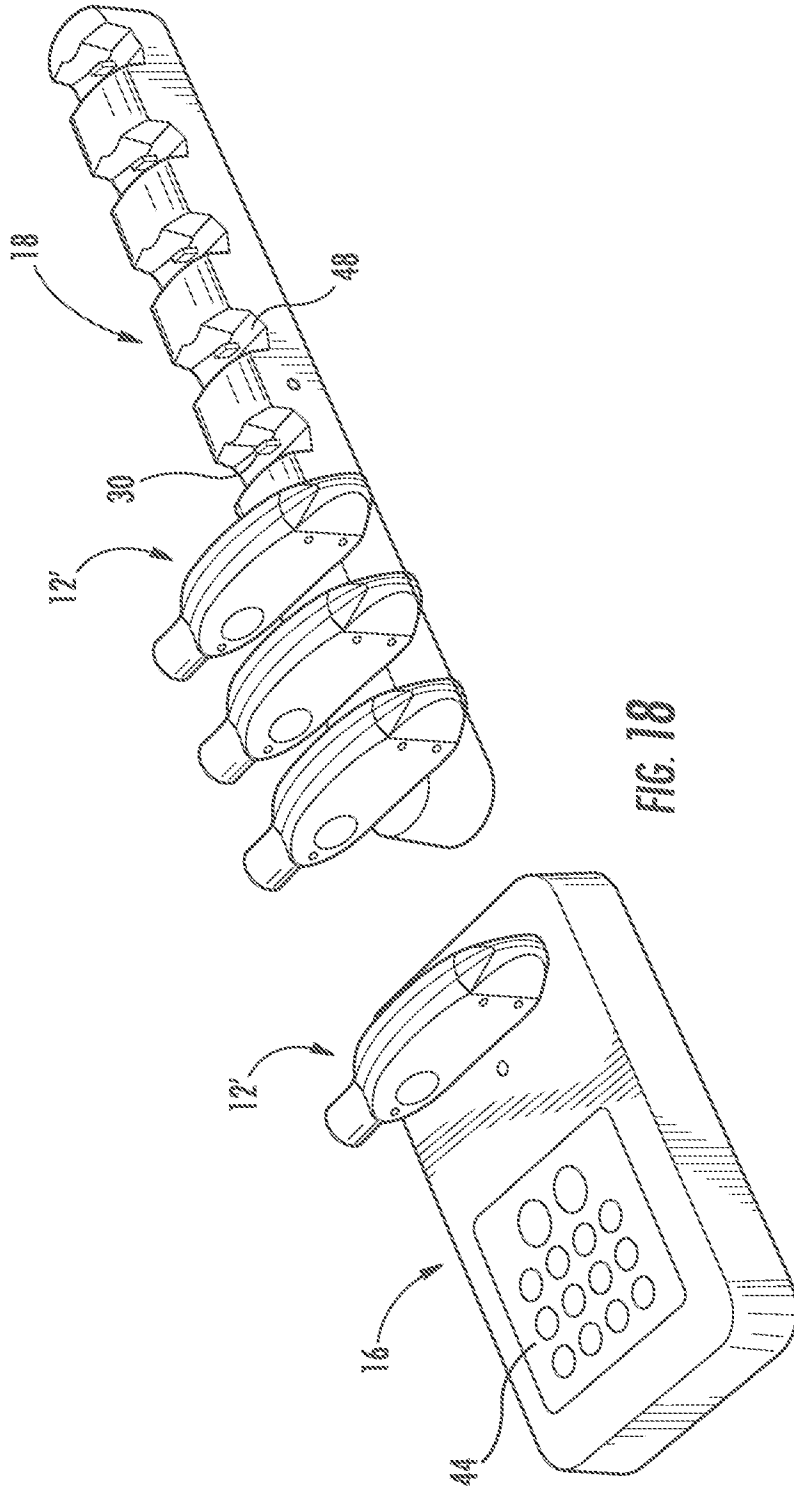

FIG. 18

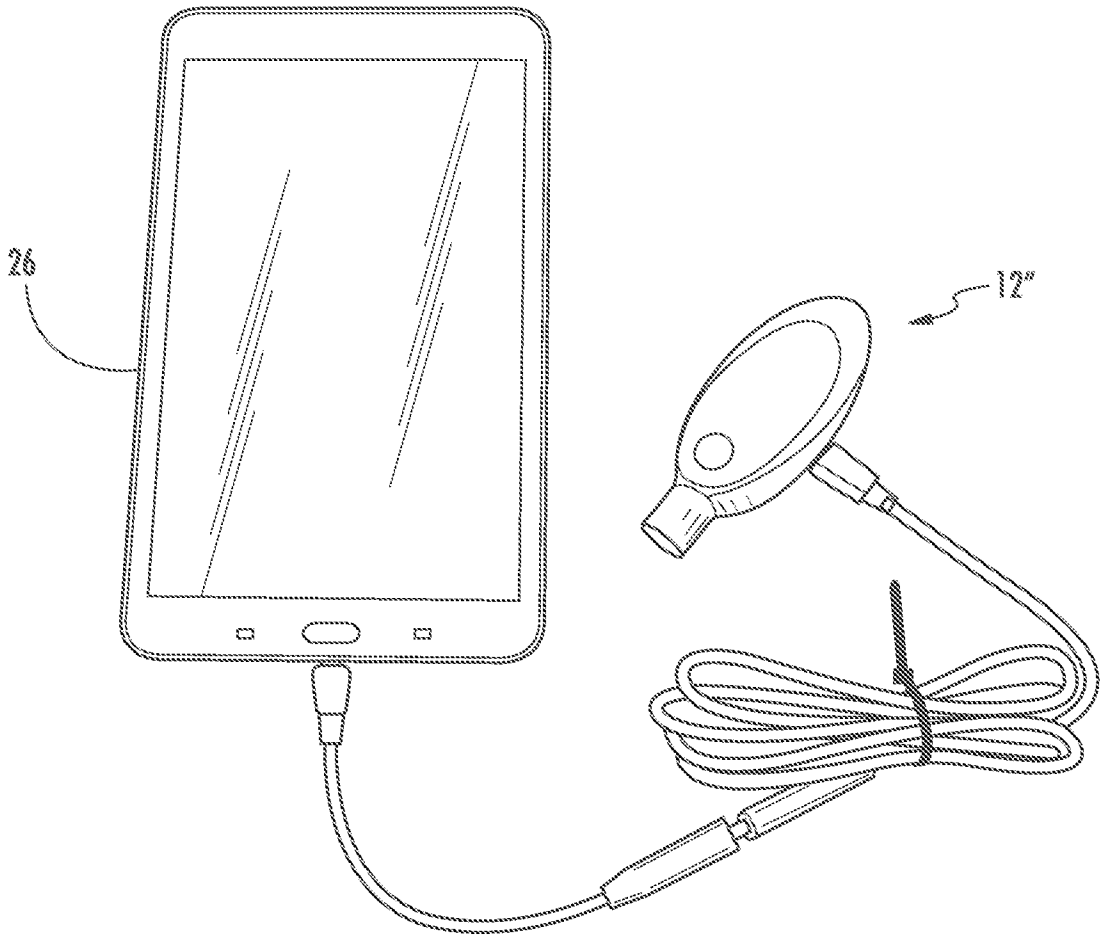

FIG. 19

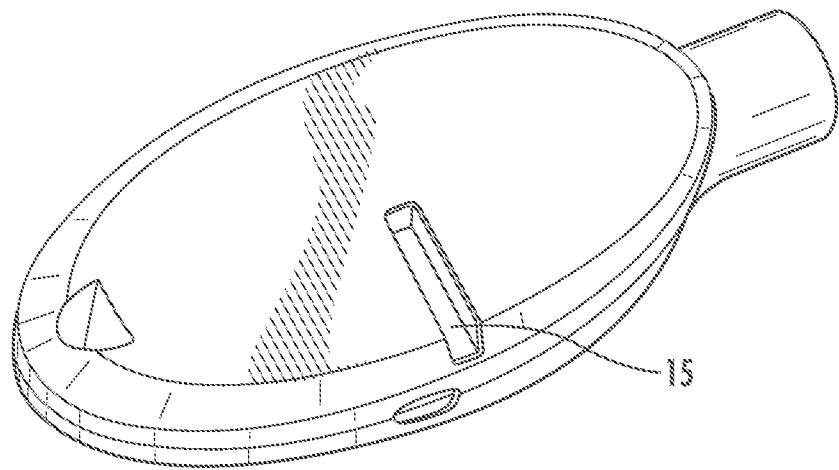
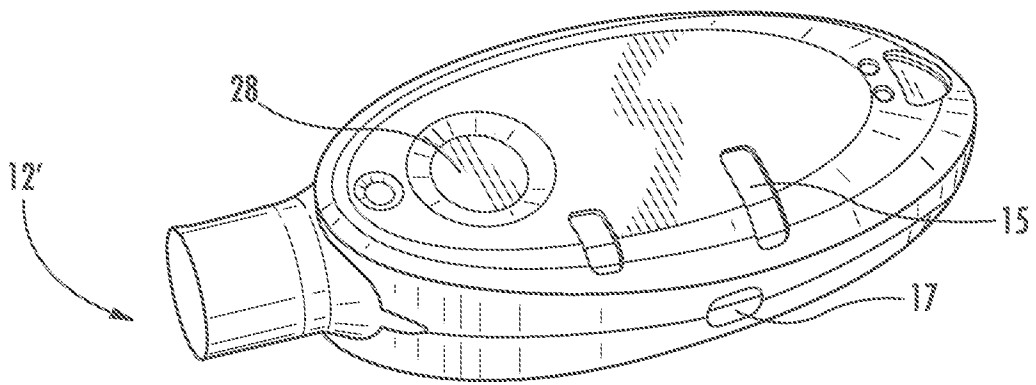

FIG. 20

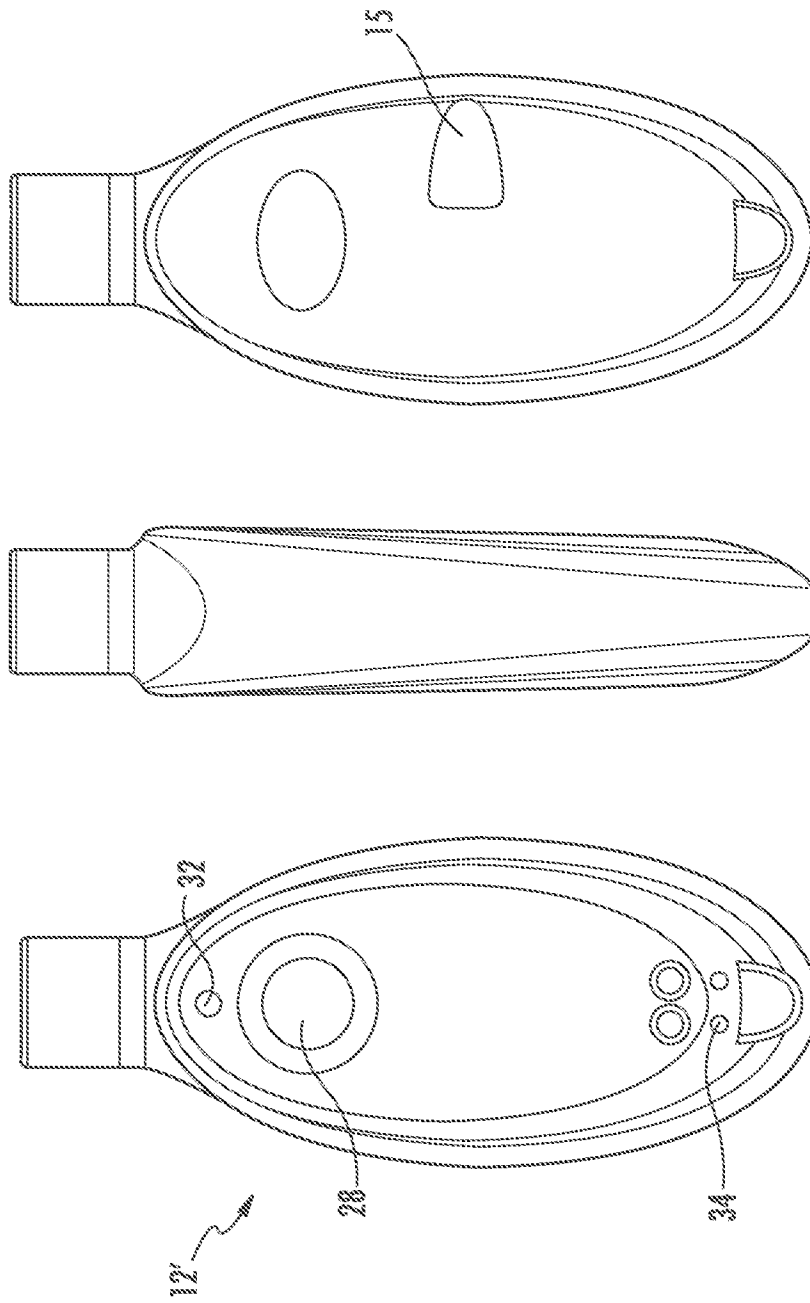

FIG. 21

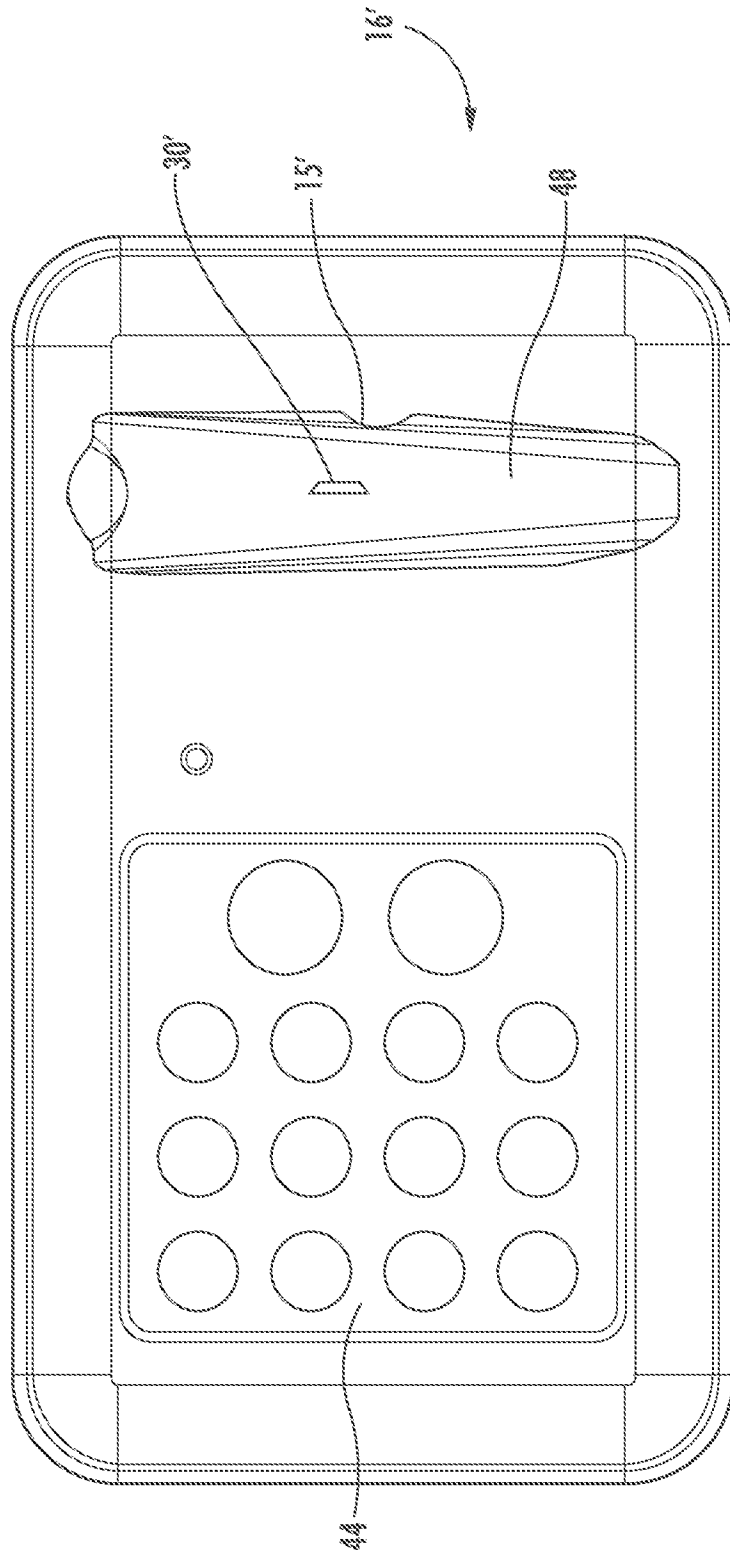

FIG. 22

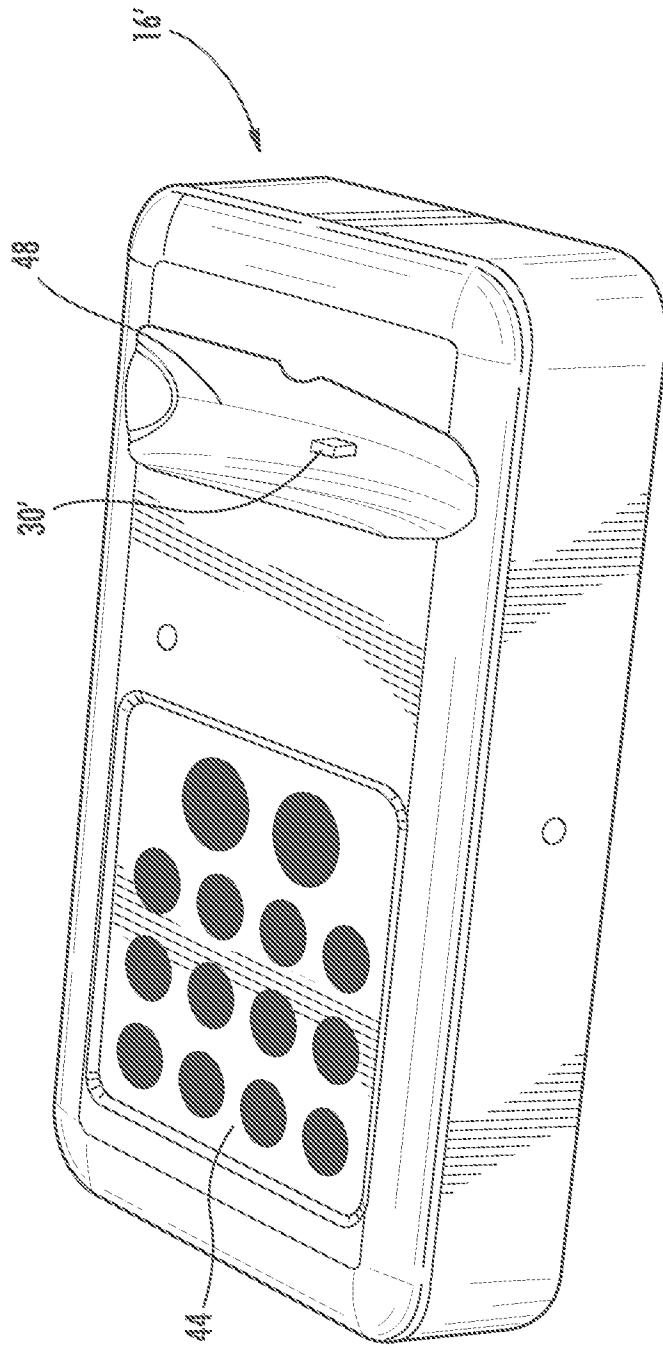

FIG. 23

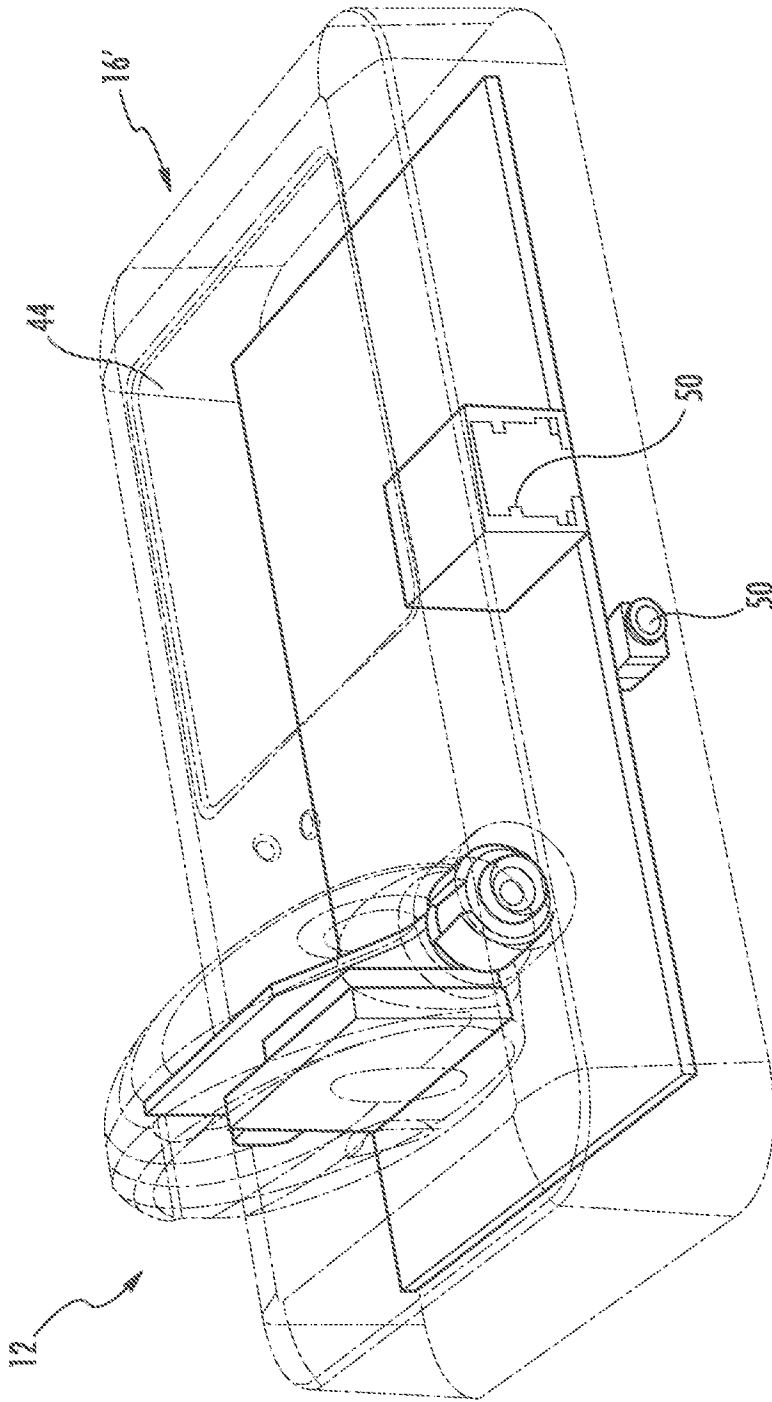

FIG. 24

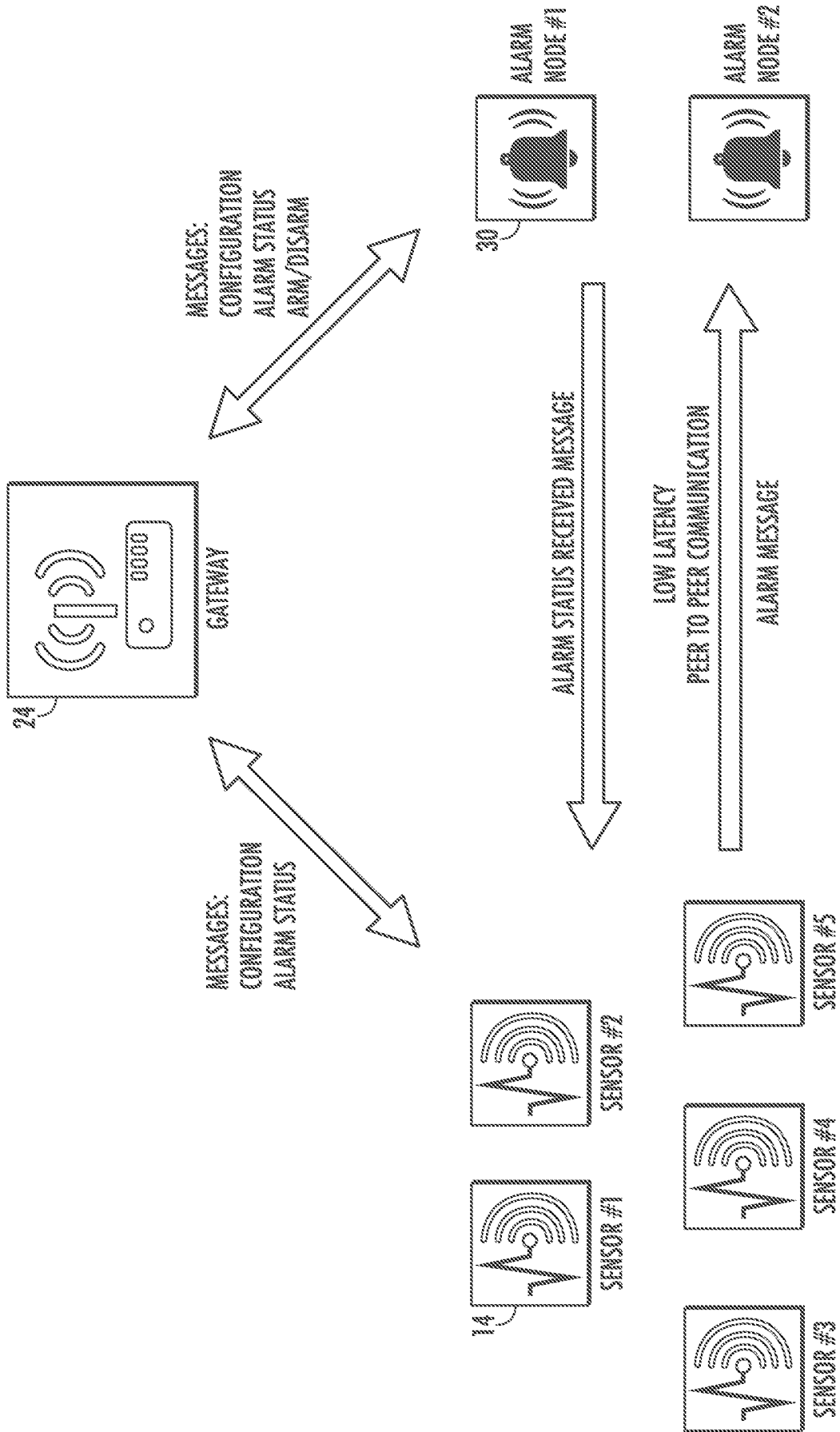

FIG. 25

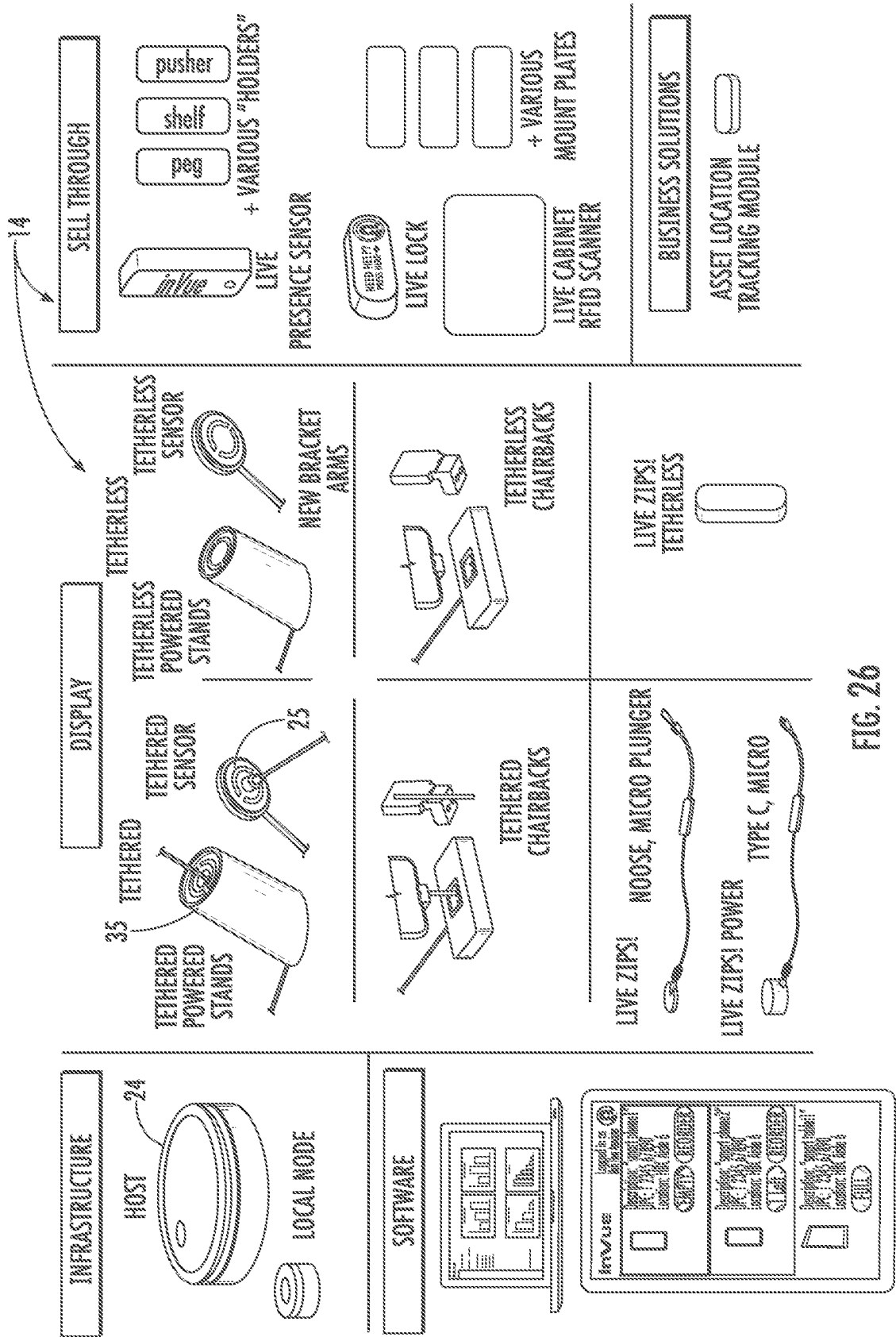

FIG. 26

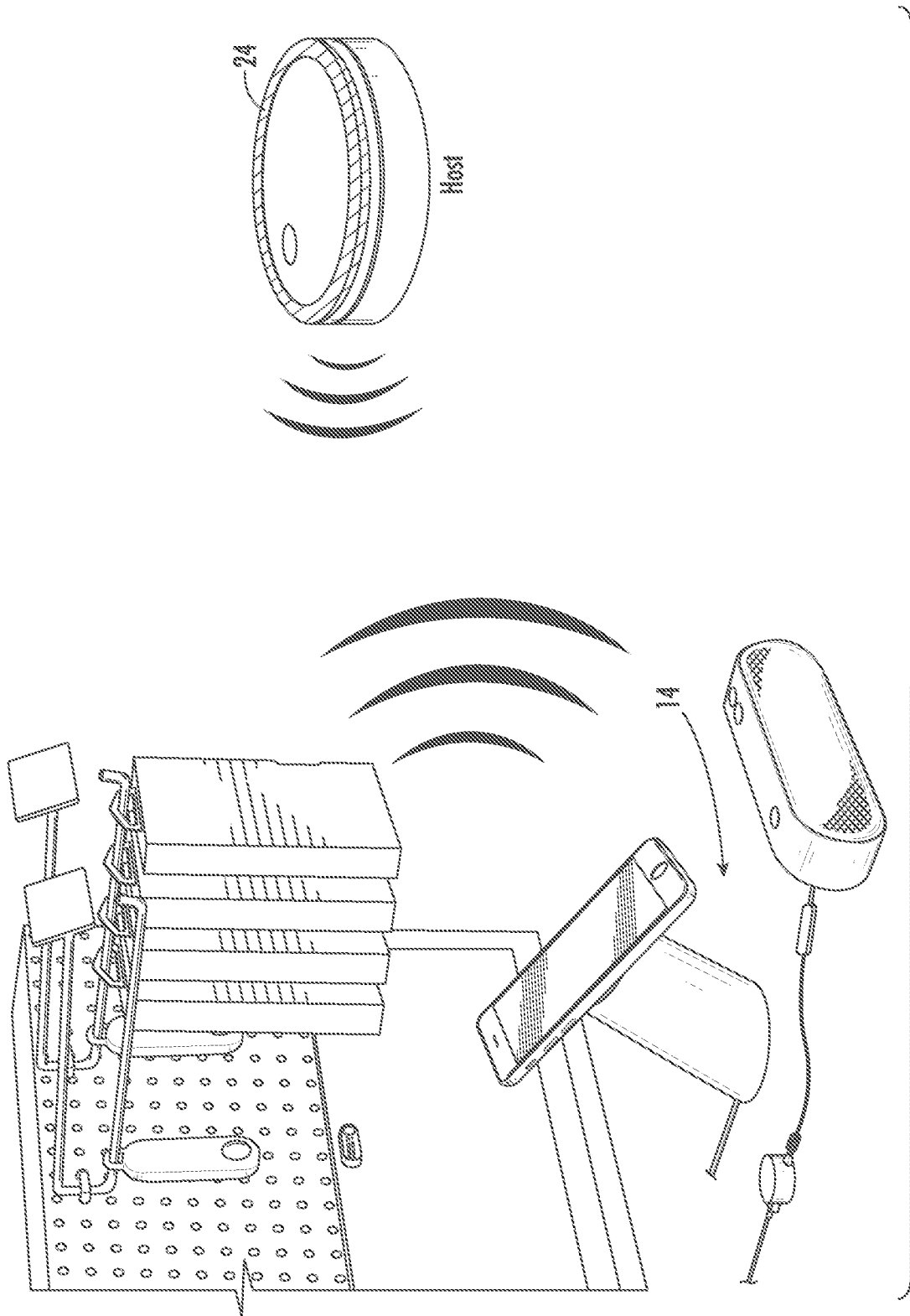

FIG. 27

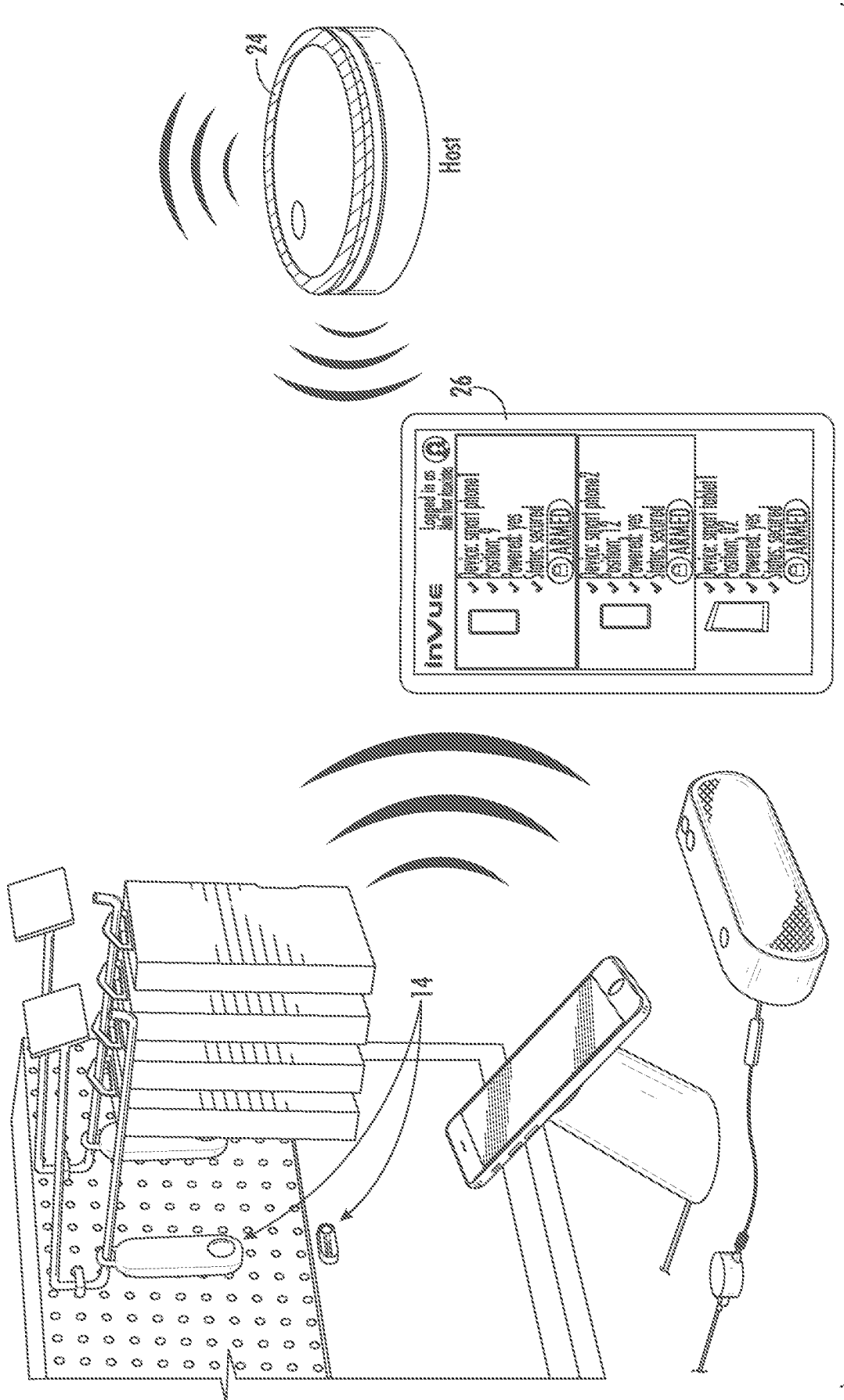

FIG. 28

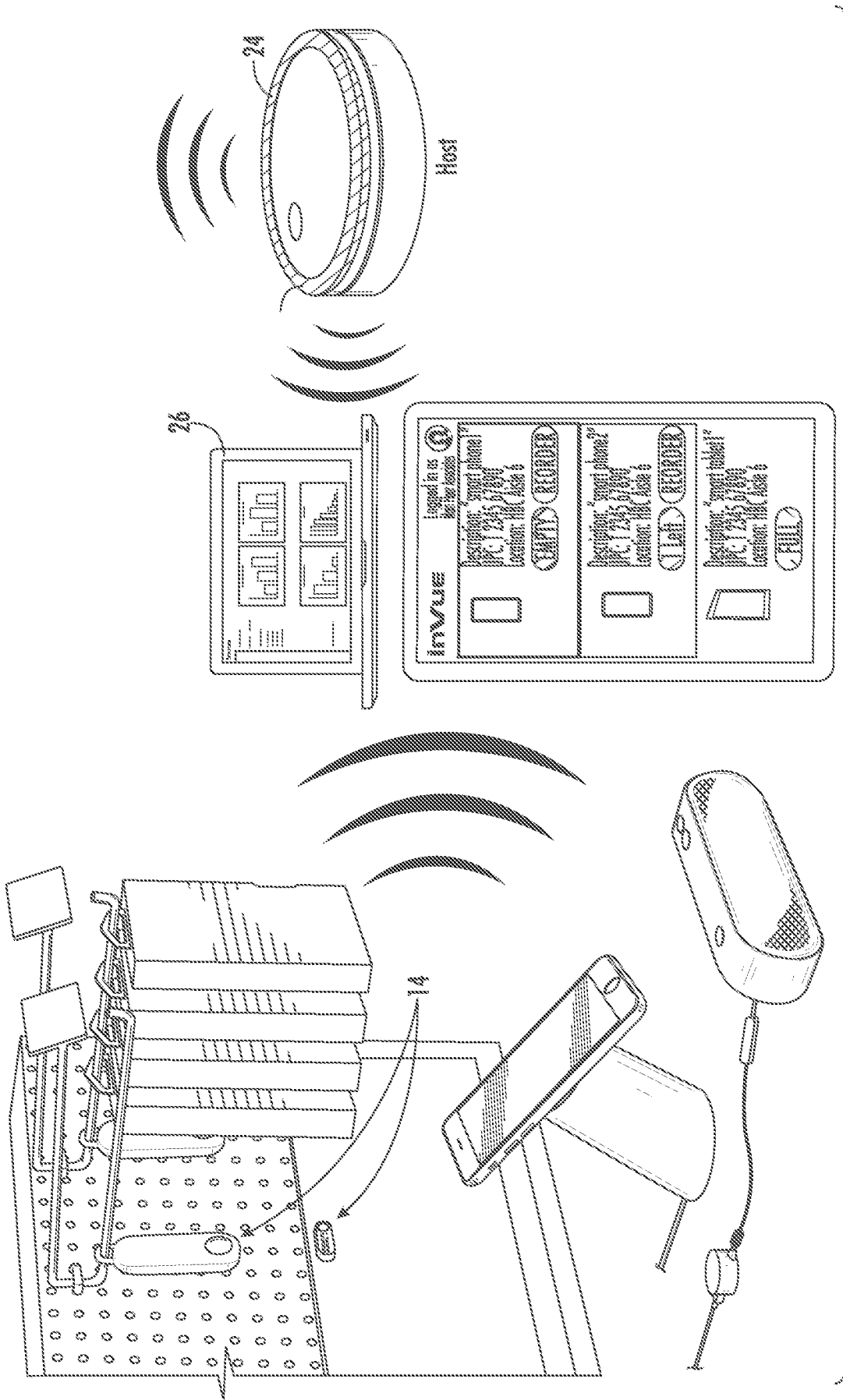

FIG. 29

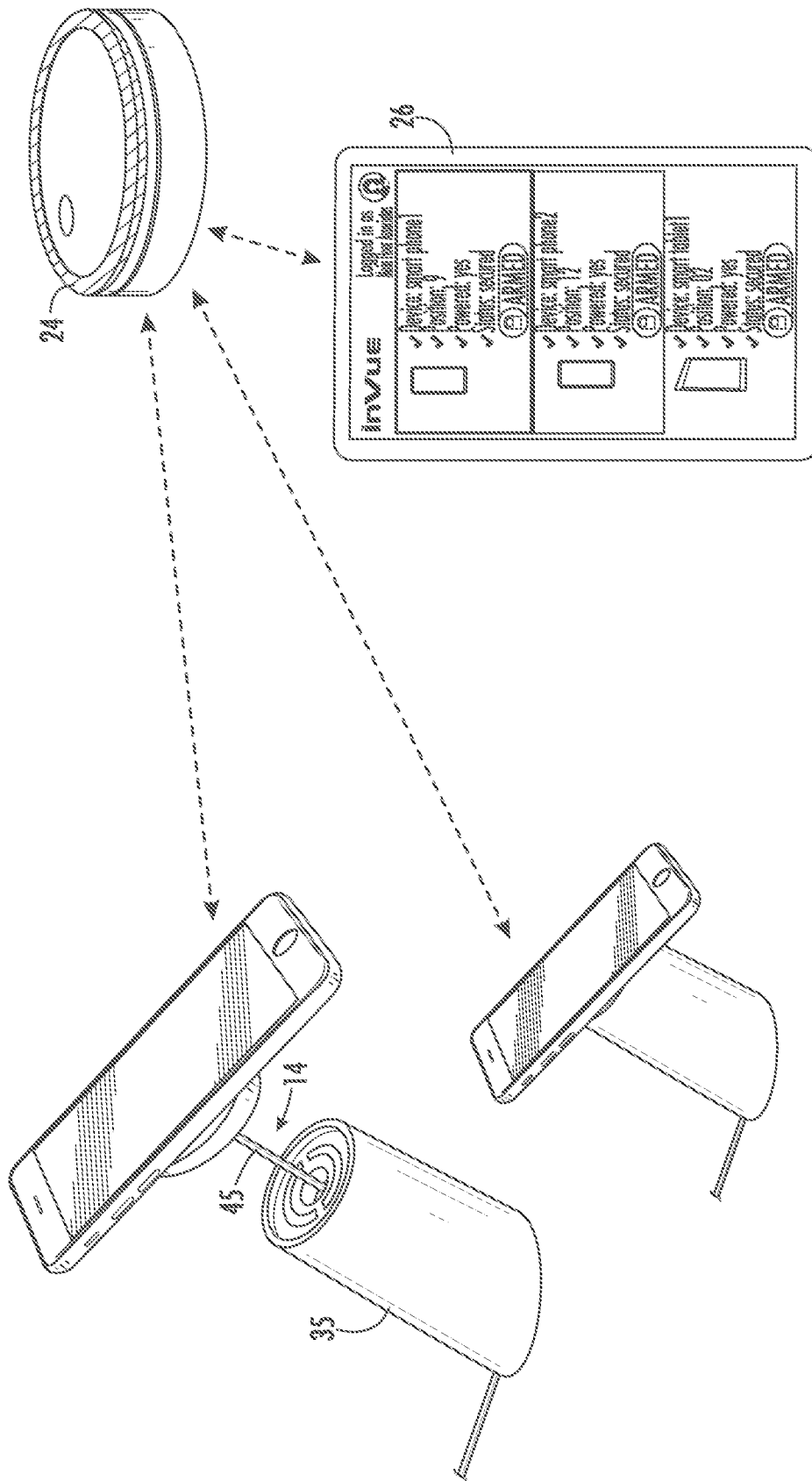

FIG. 30

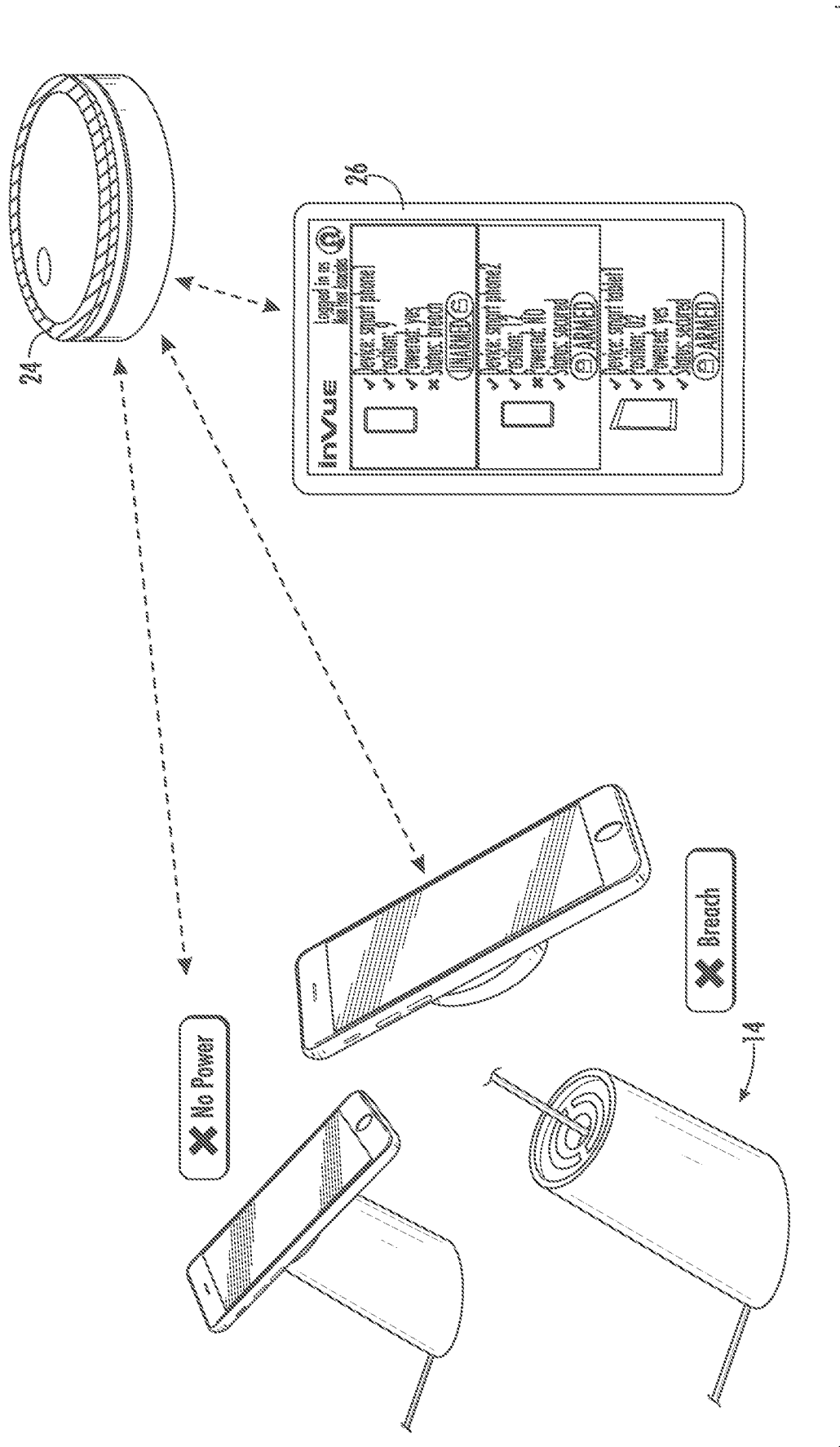

FIG. 31

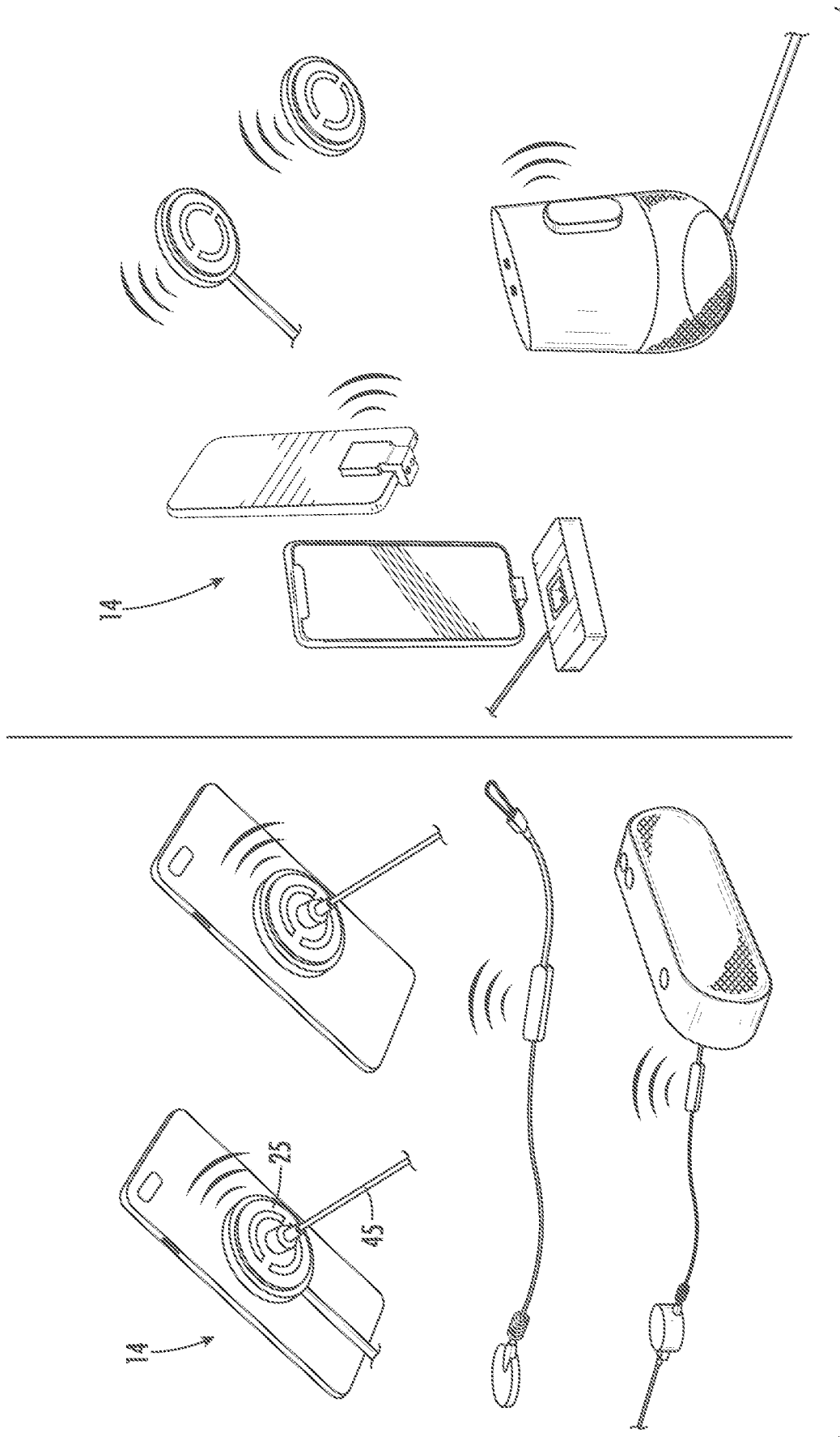

FIG. 32

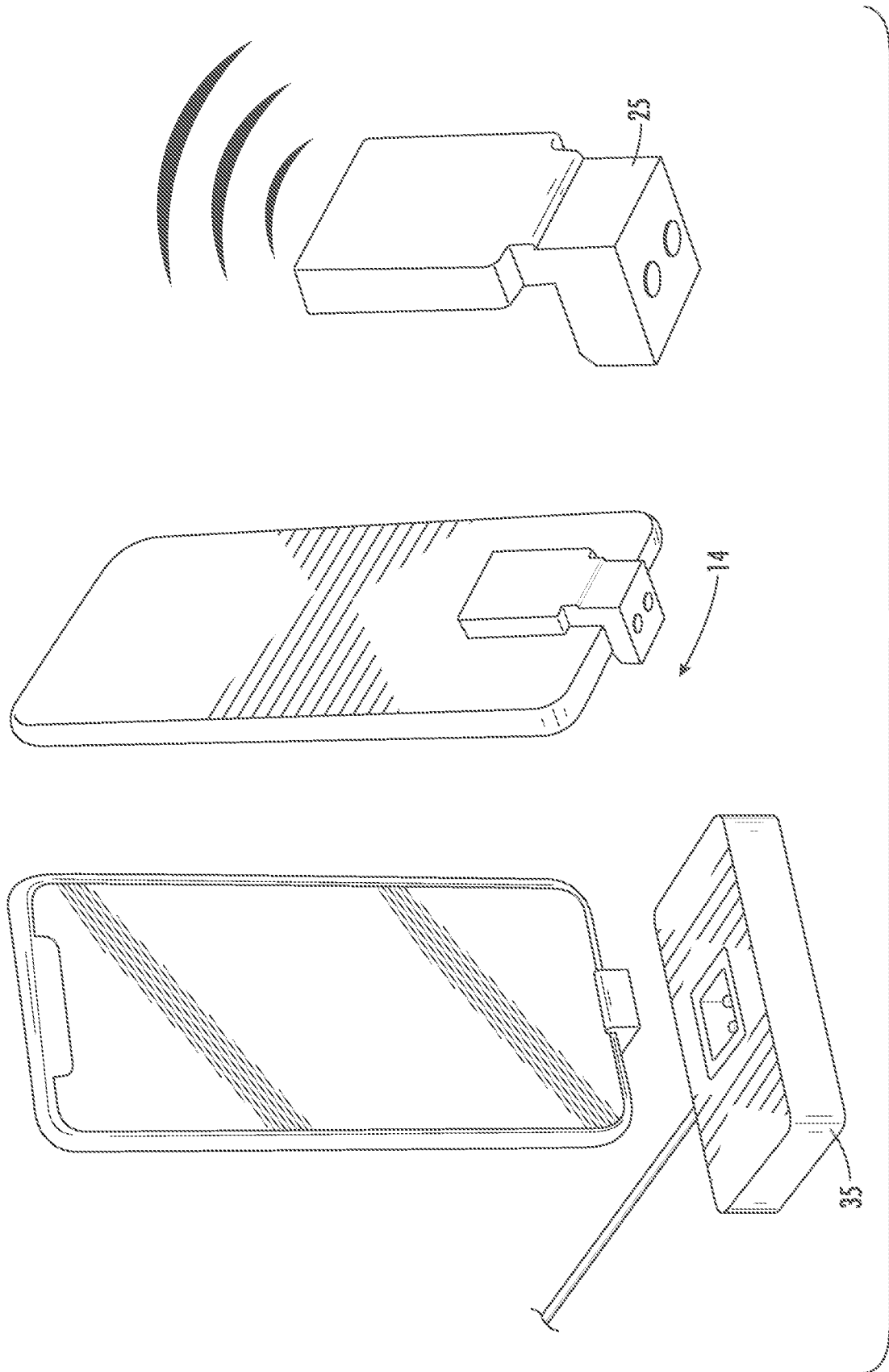
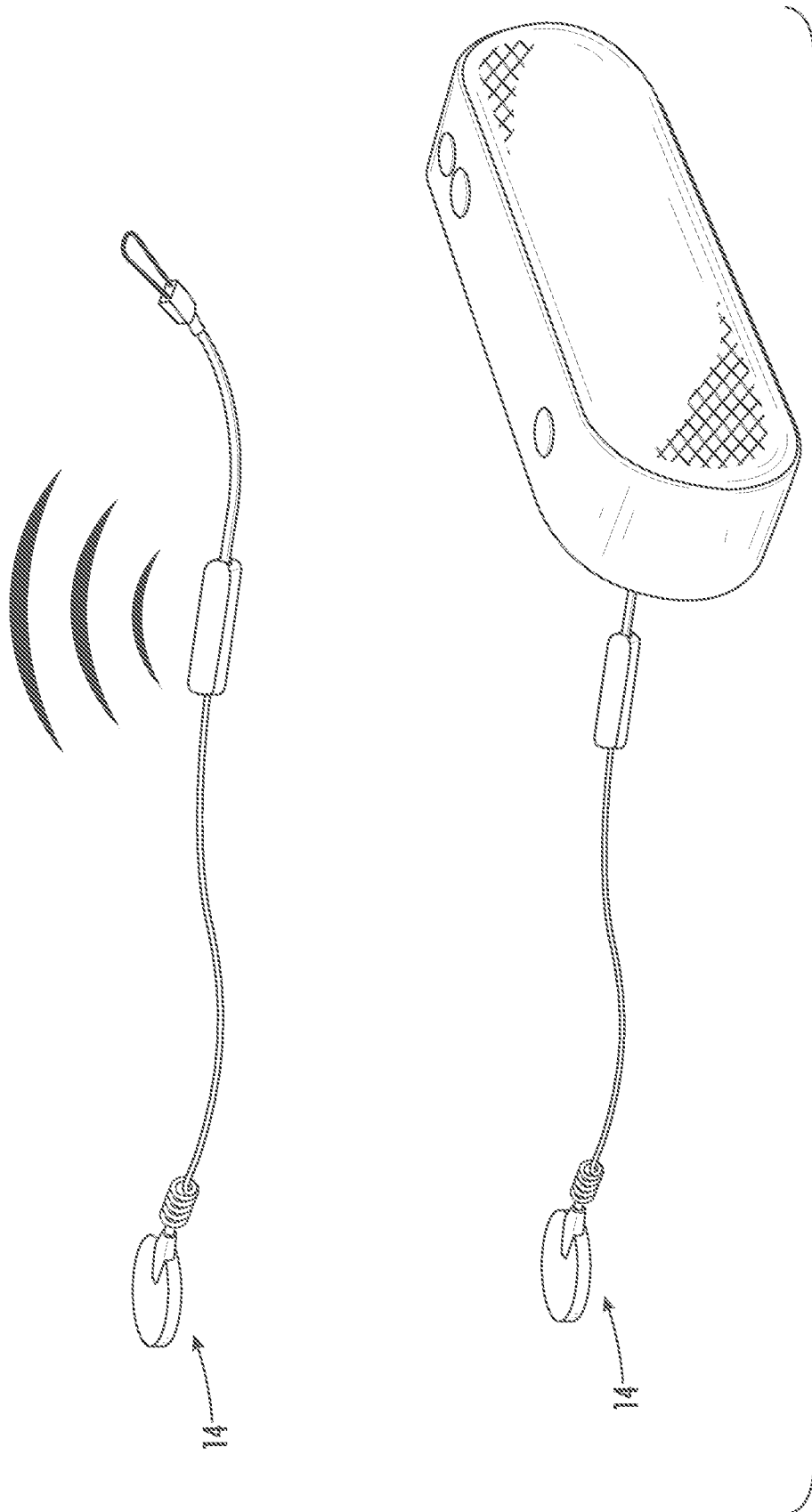
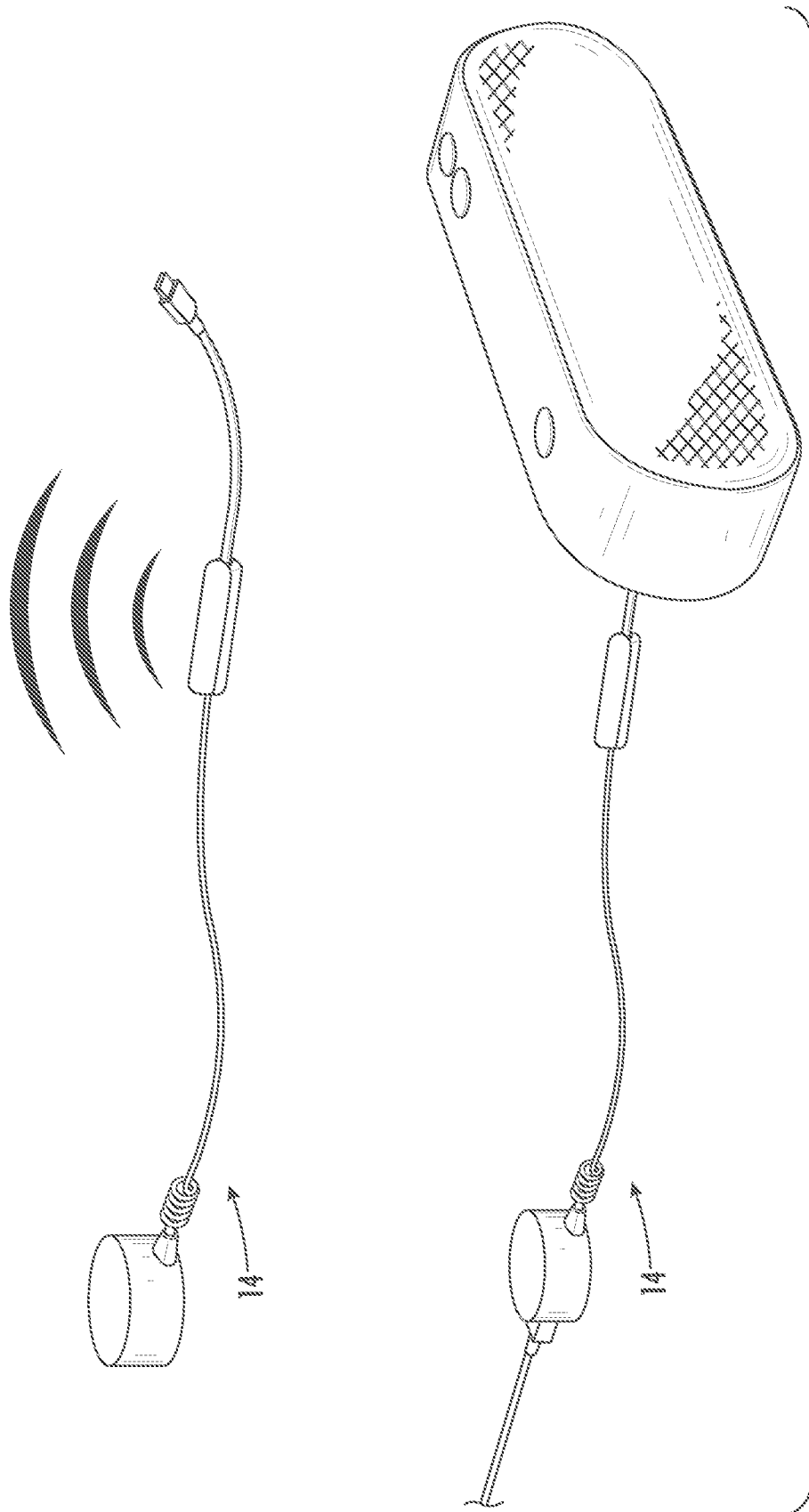

FIG. 33





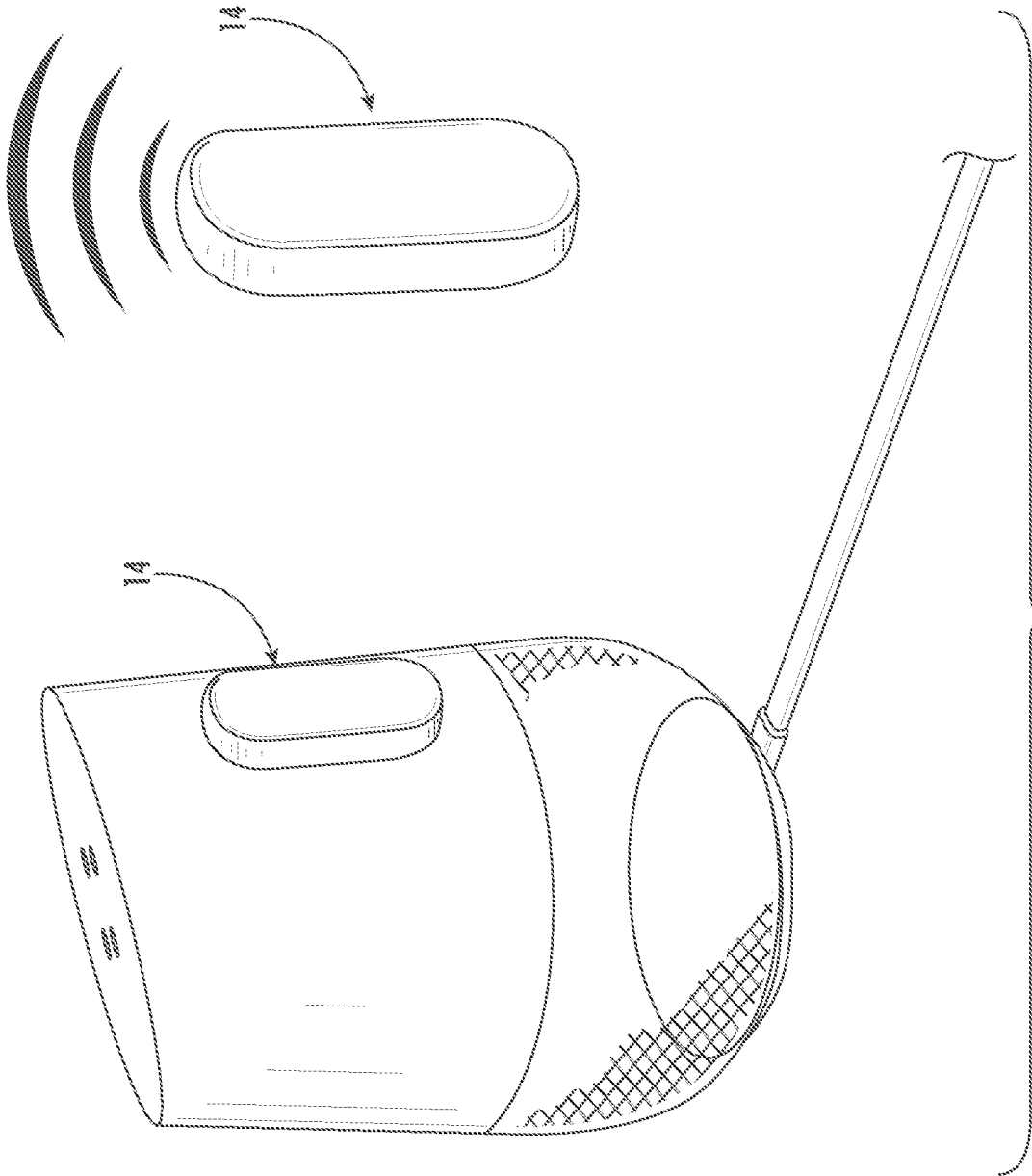

FIG. 36

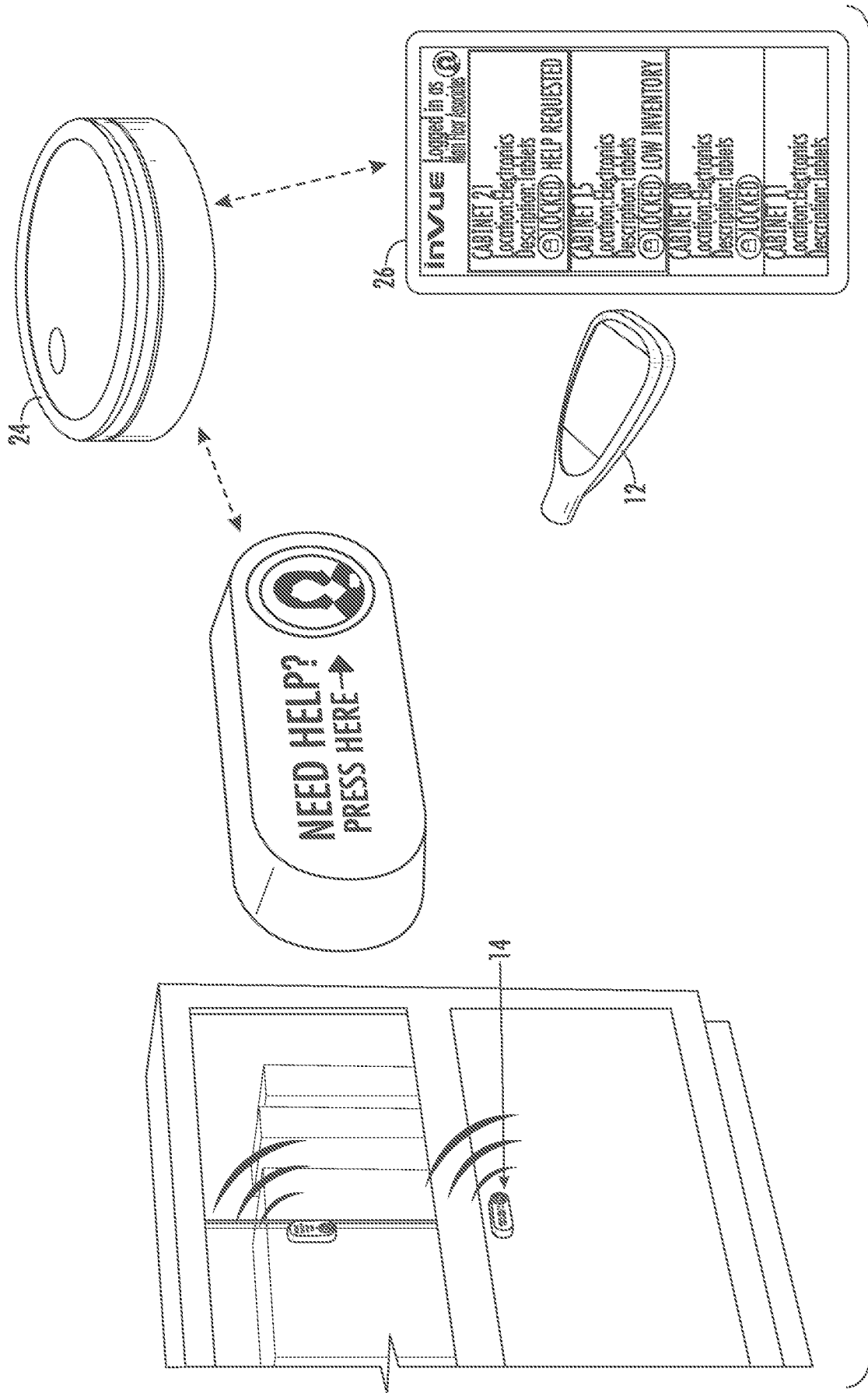

FIG. 37

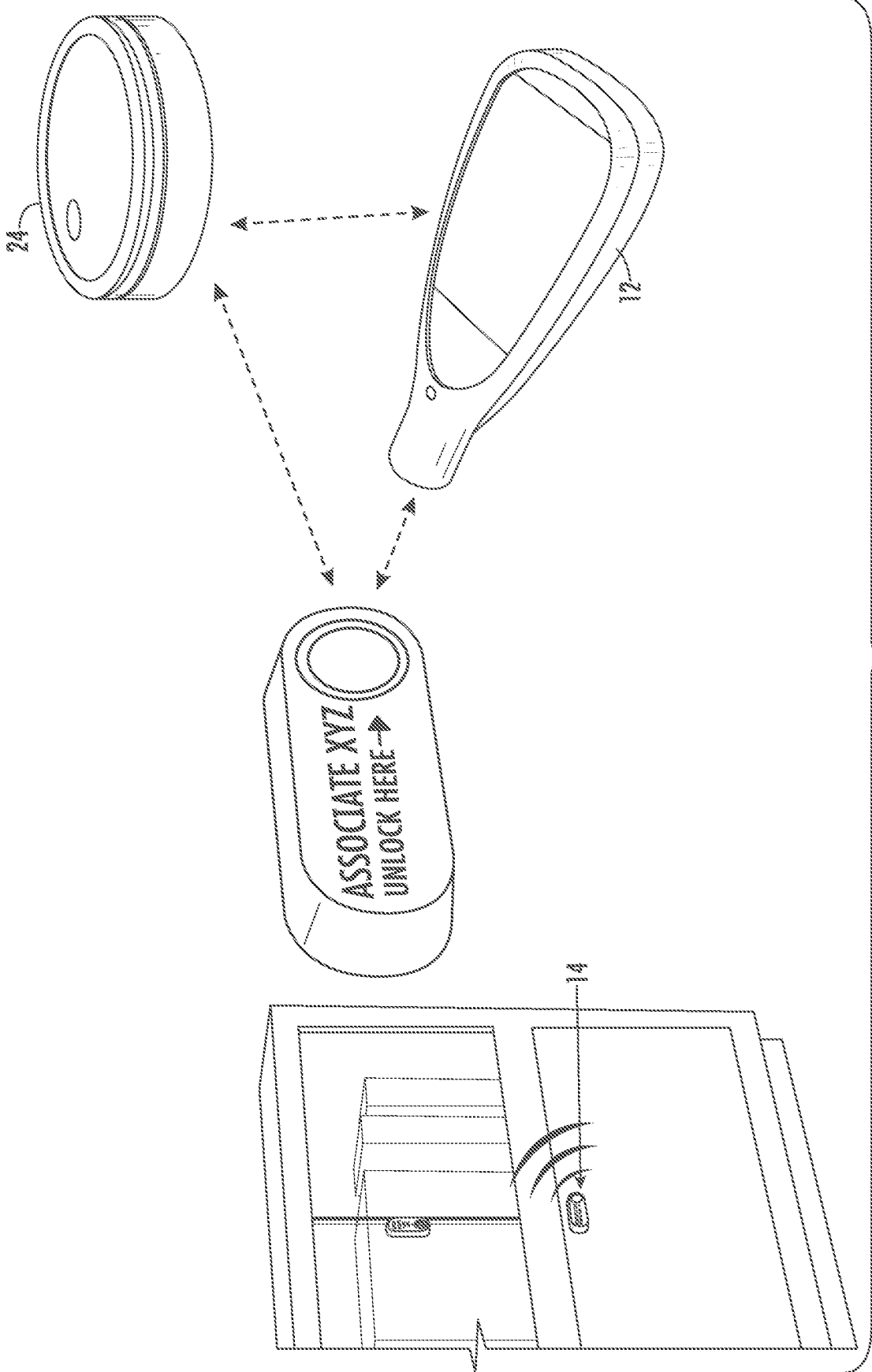

FIG. 38

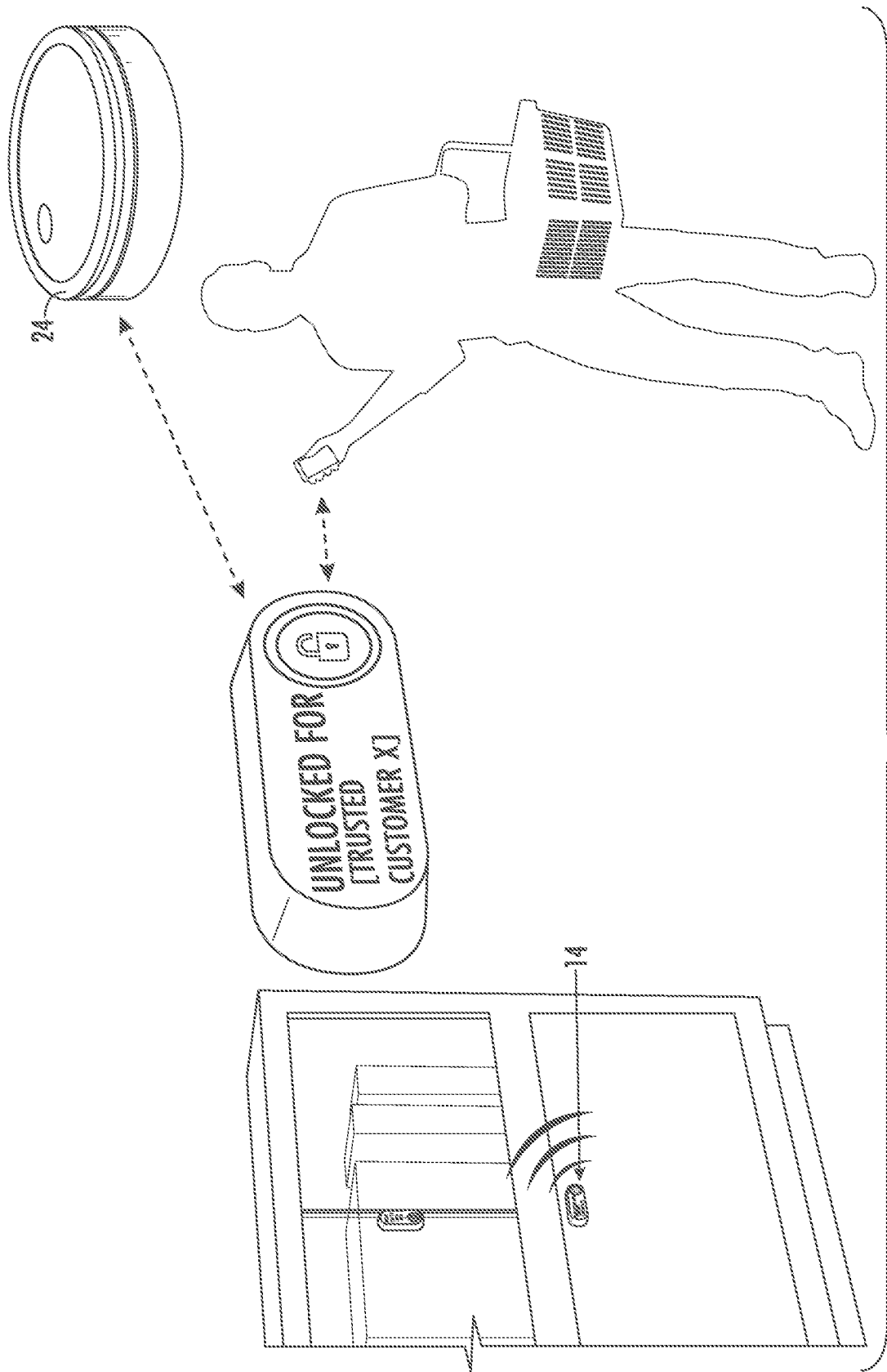

FIG. 39

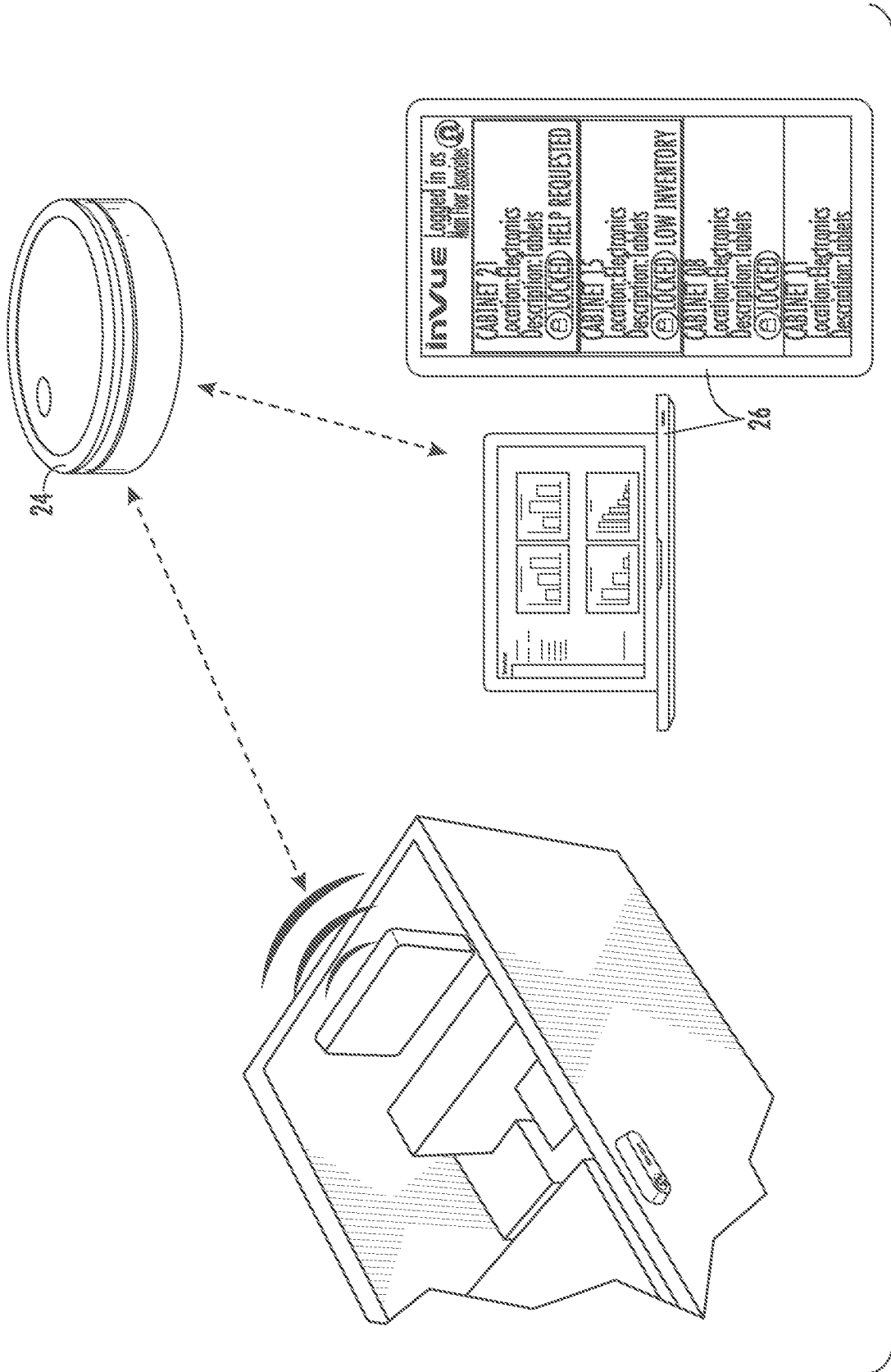

FIG. 40

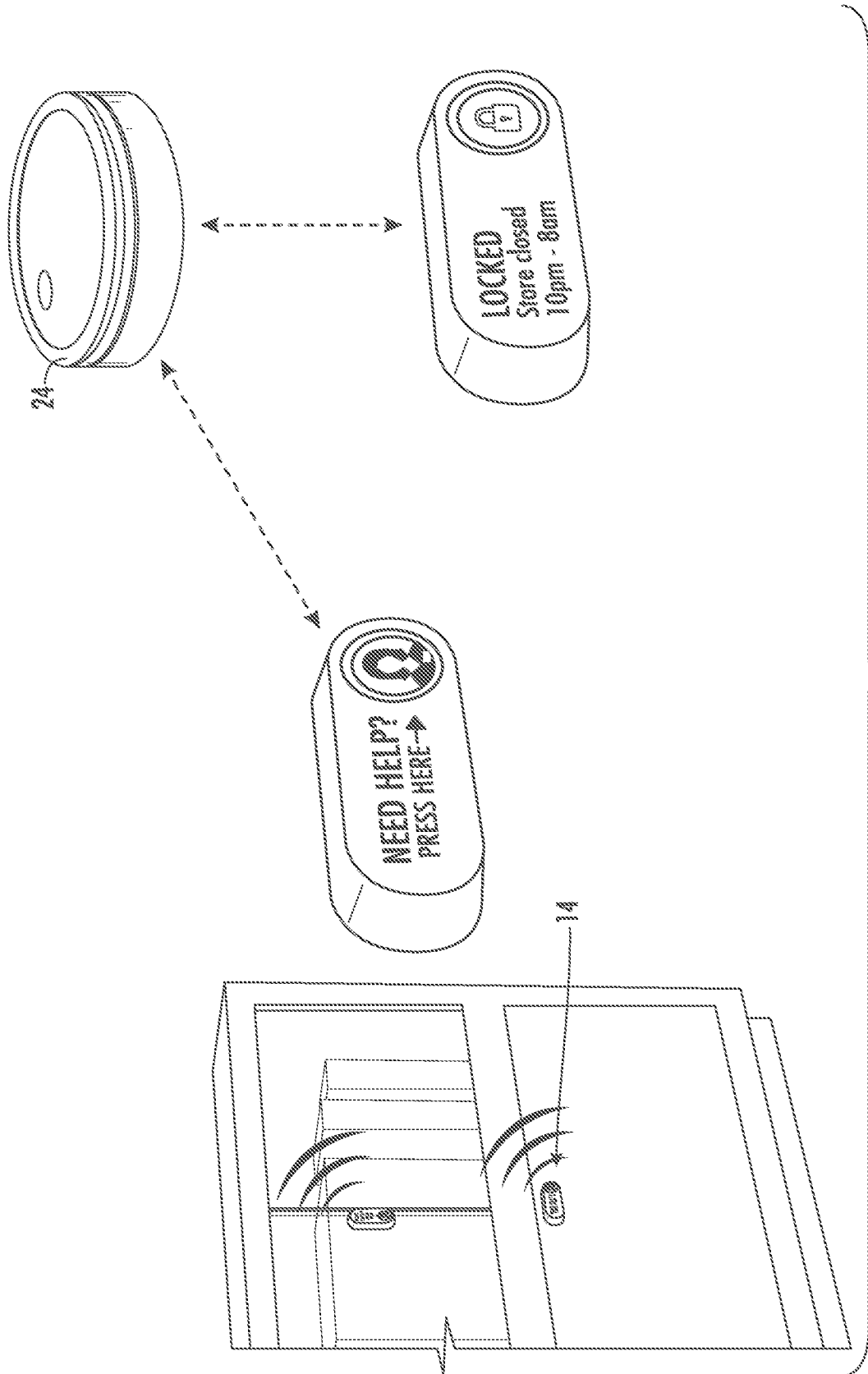

FIG. 41

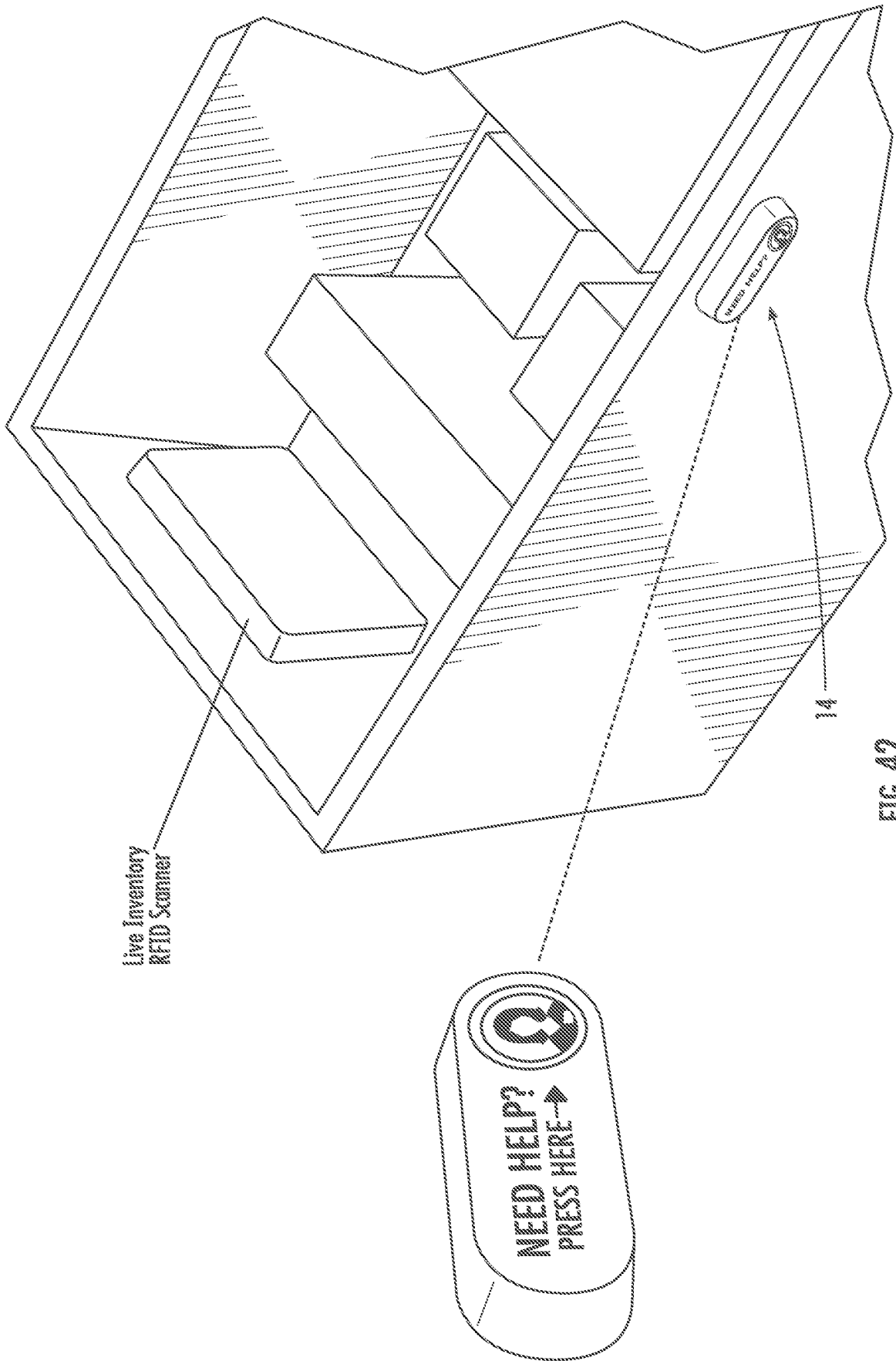
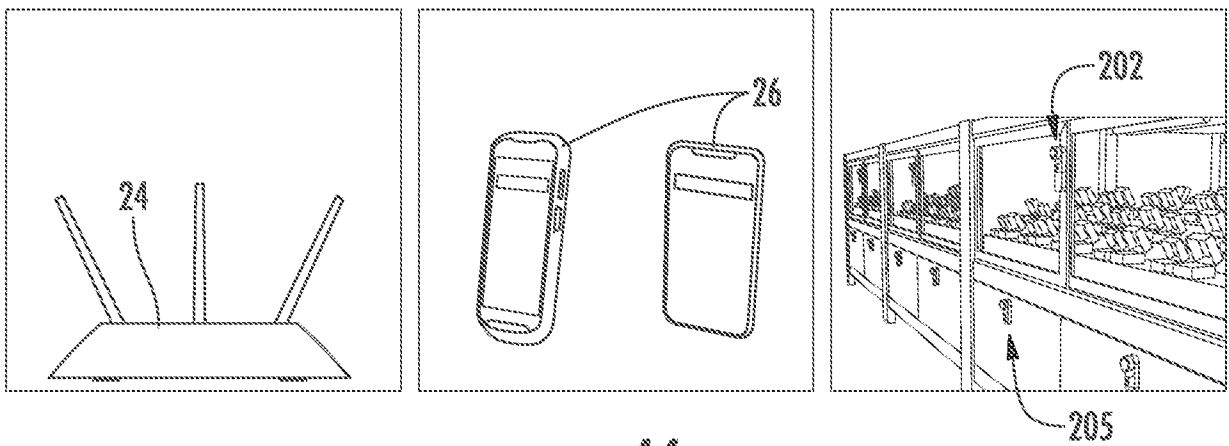
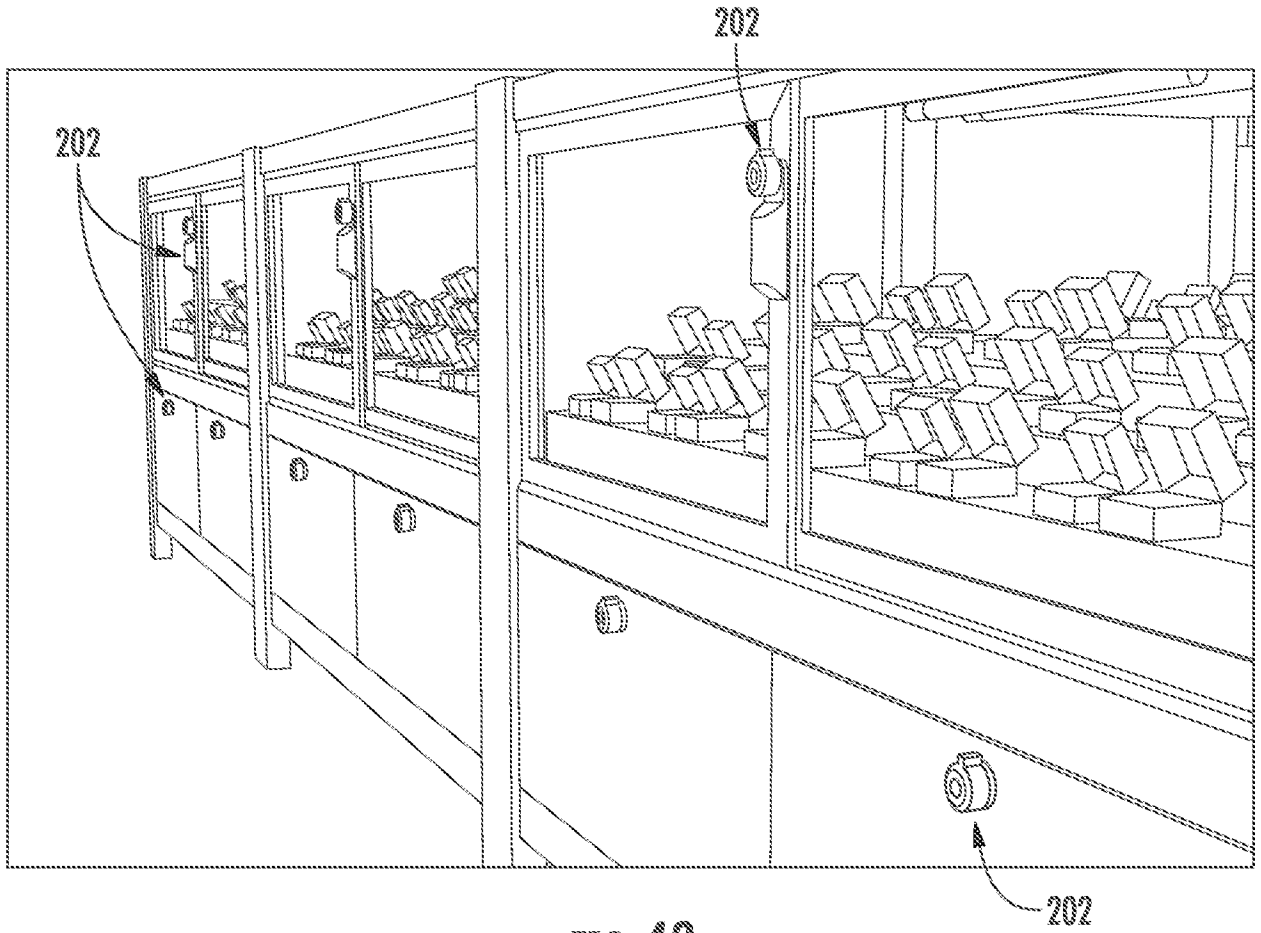

FIG. 42



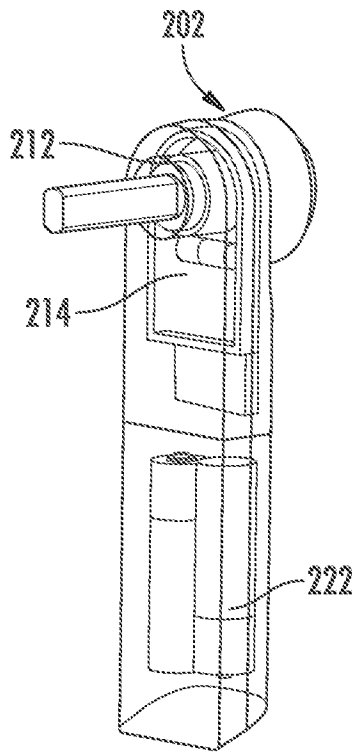

FIG. 45A

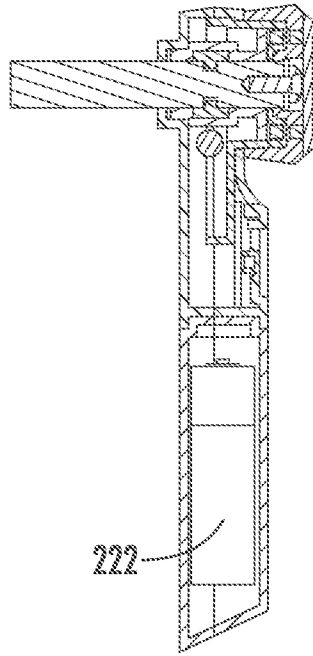

FIG. 45B

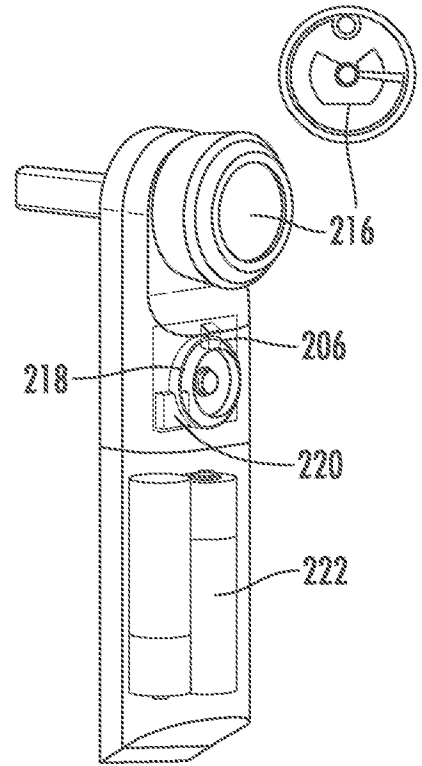

FIG. 45C

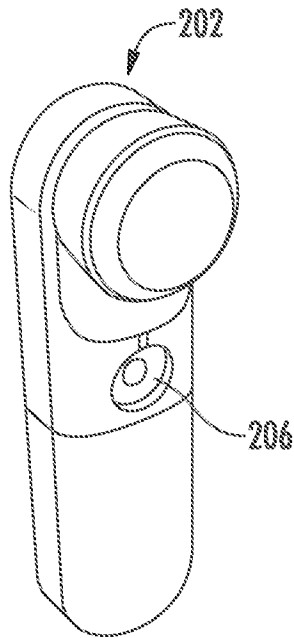

FIG. 46A

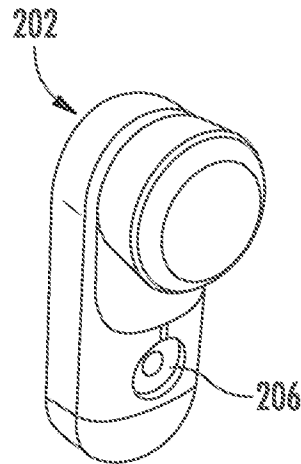

FIG. 46B

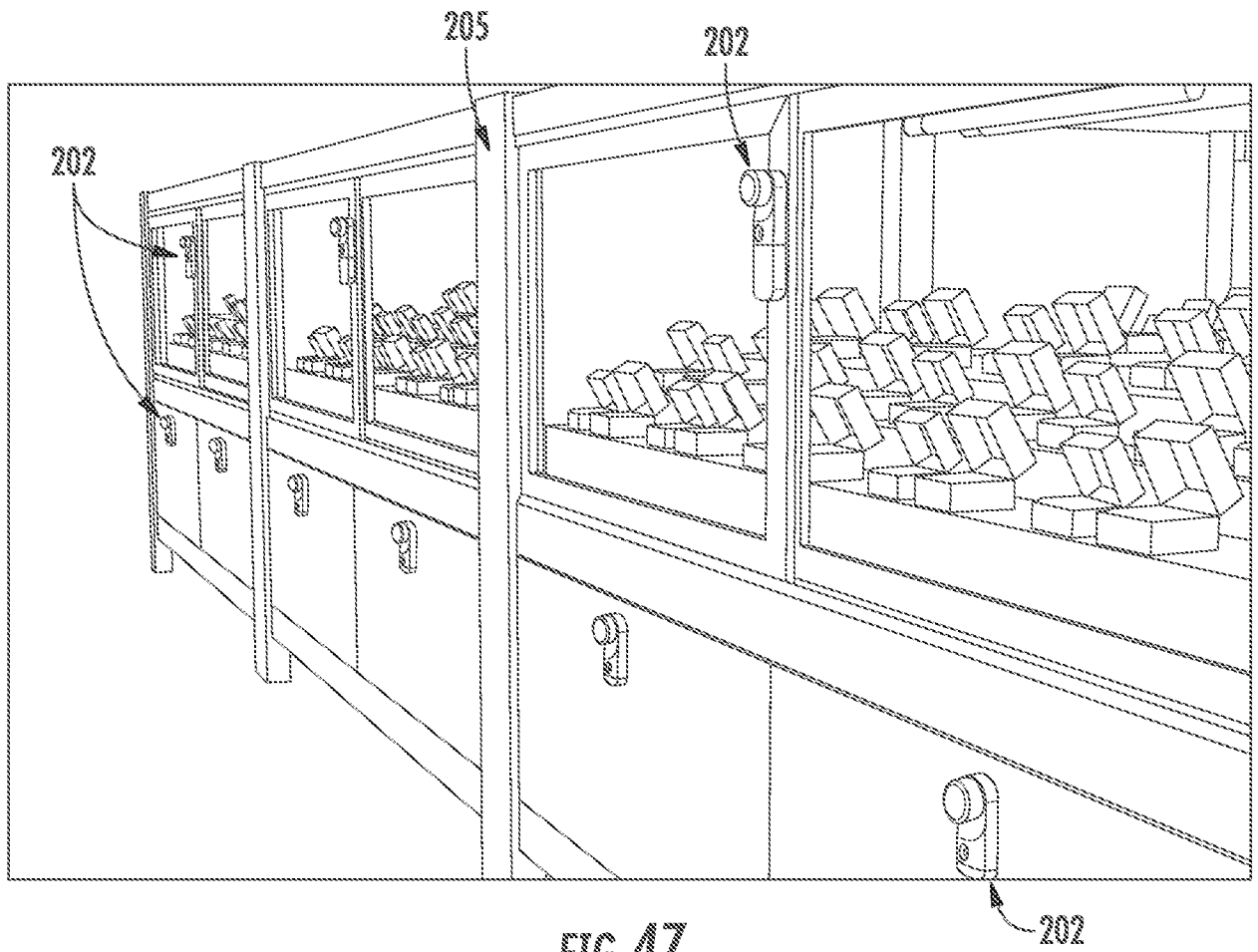

FIG. 47

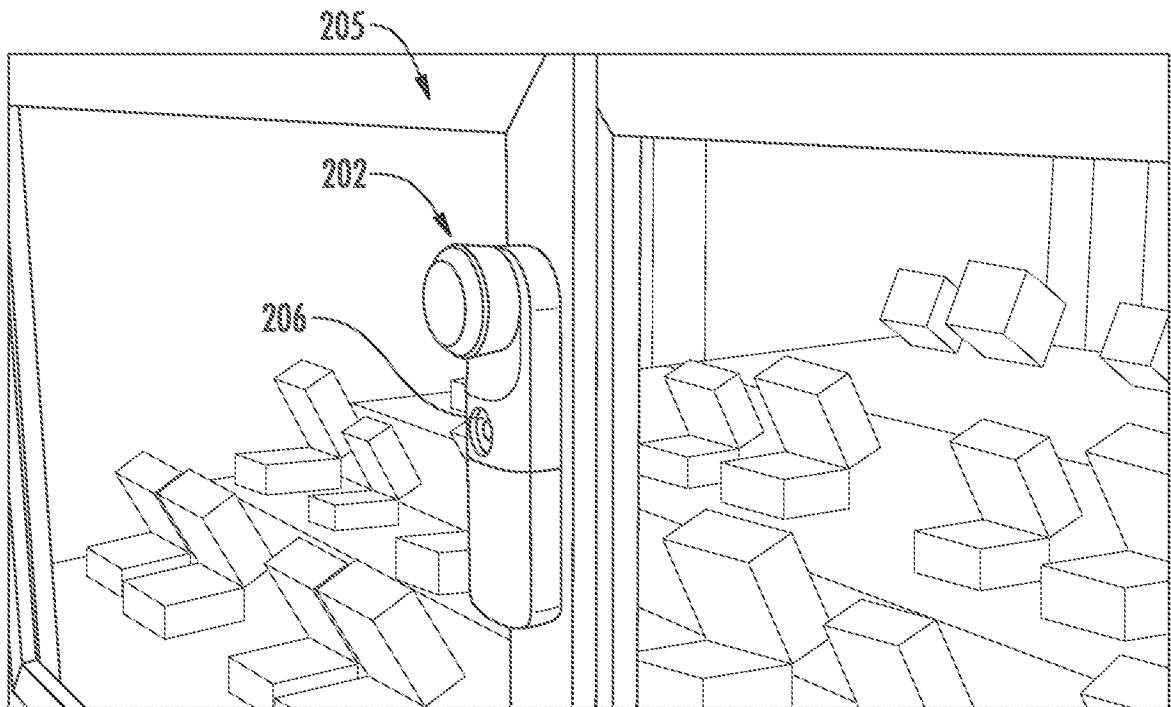

FIG. 48

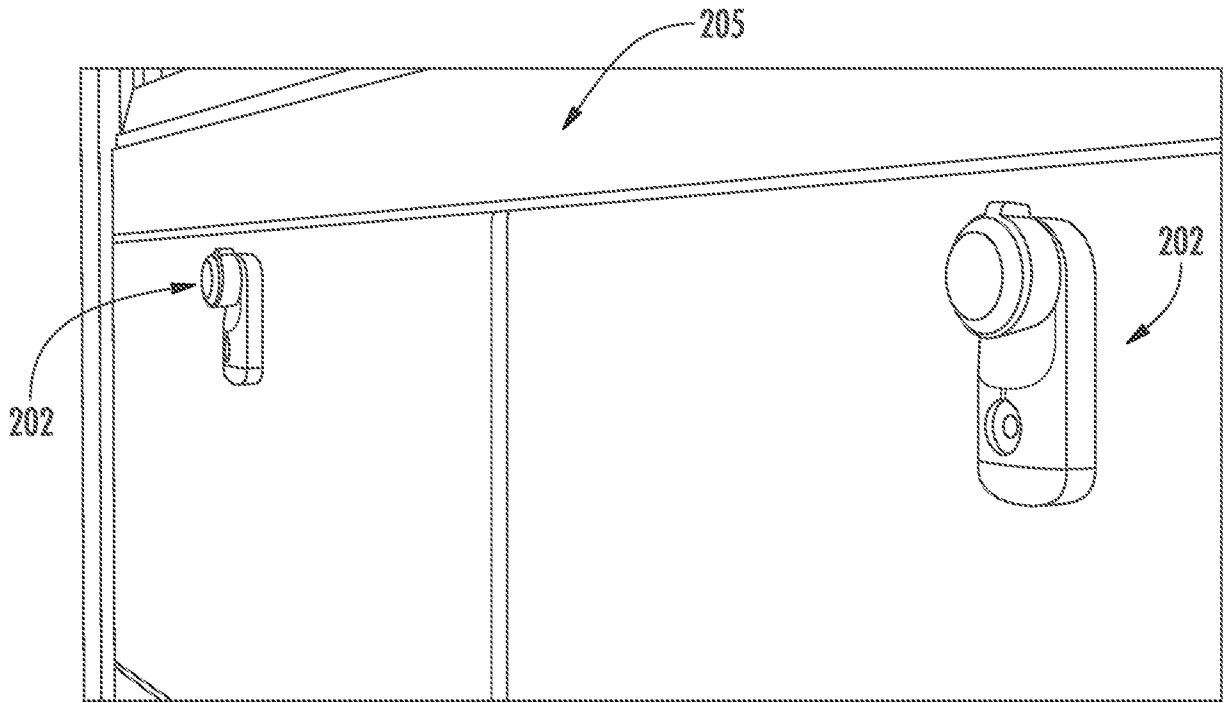

FIG. 49

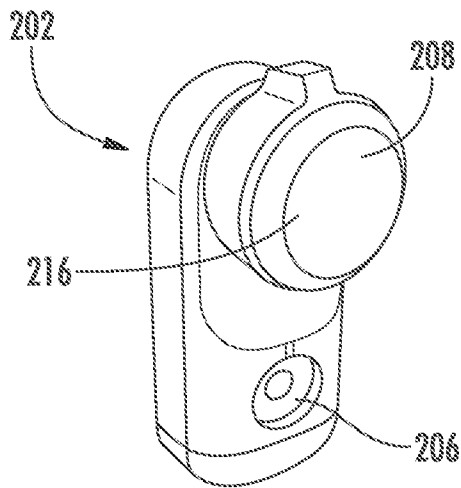

FIG. 50A

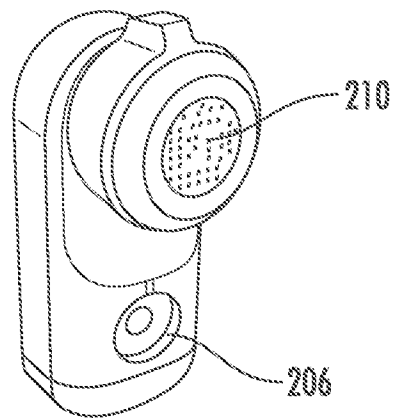

FIG. 50B

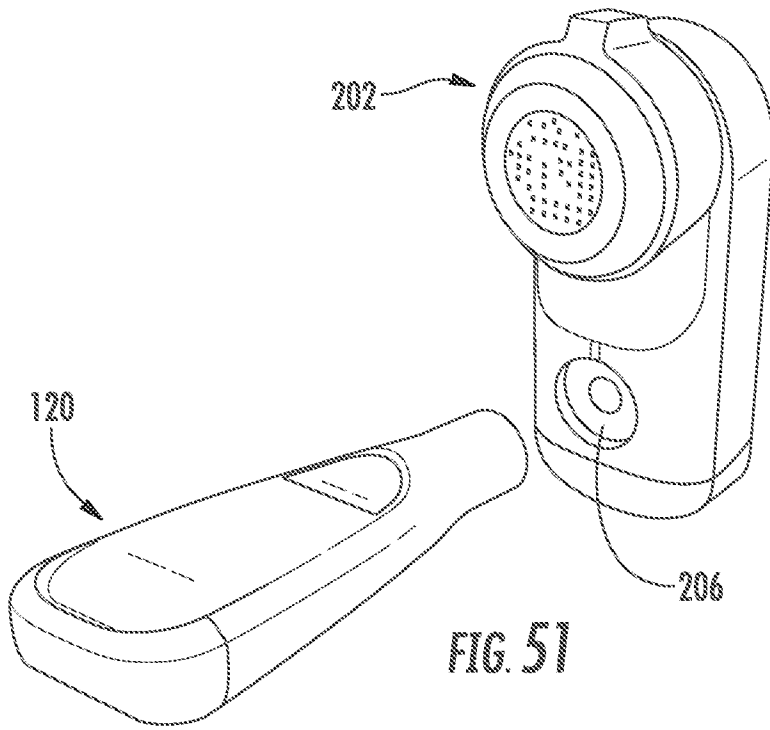

FIG. 51

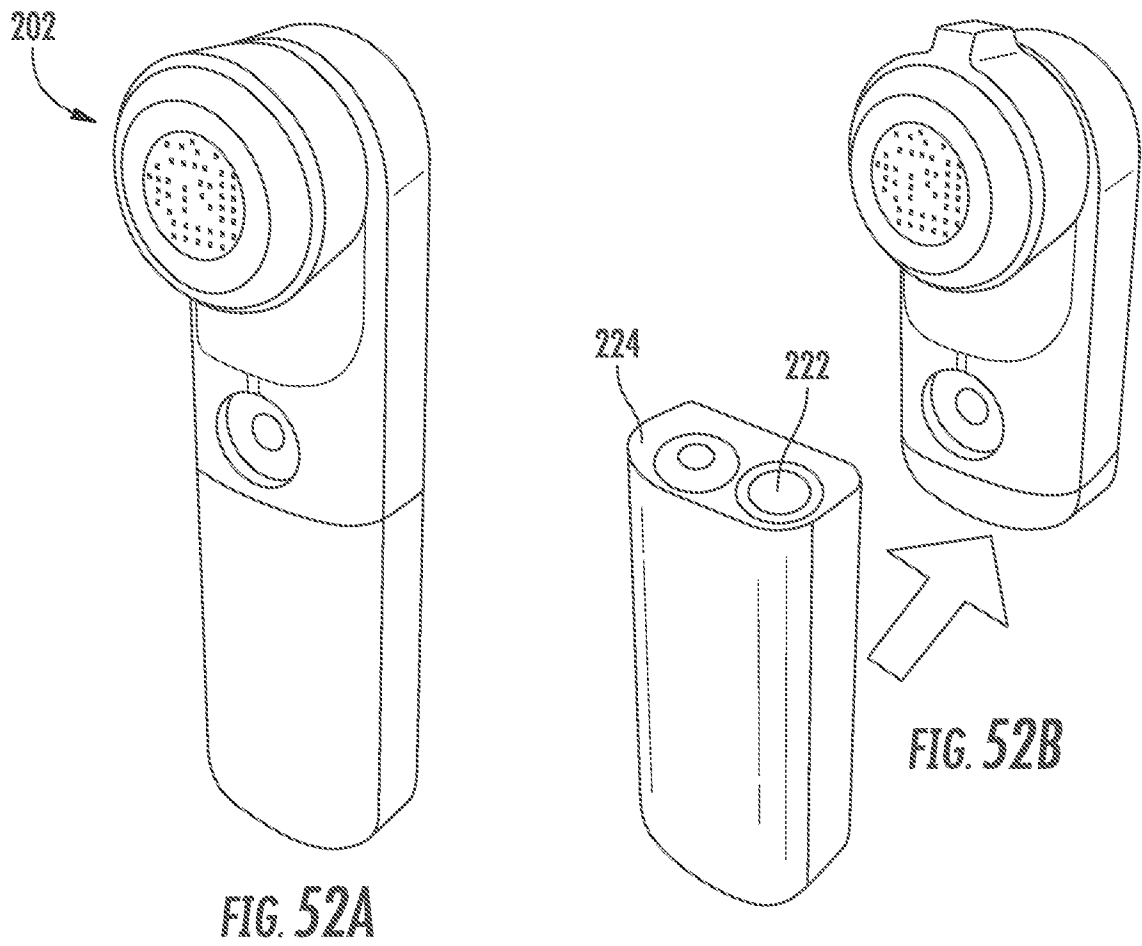

FIG. 52A

FIG. 52B

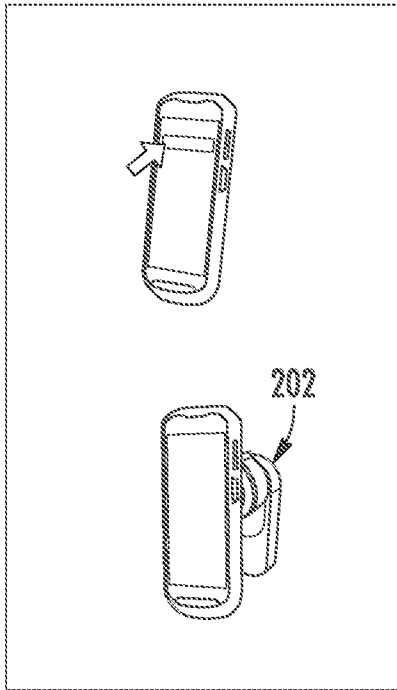

FIG. 53A

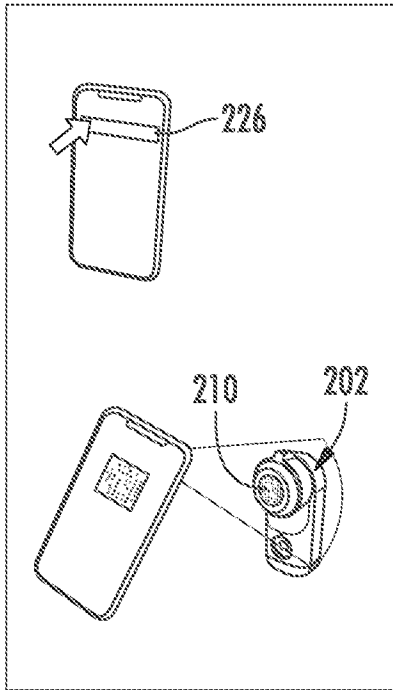

FIG. 53B

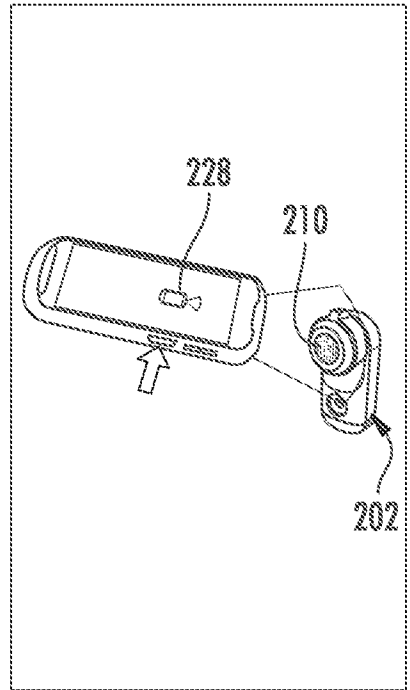

FIG. 53C

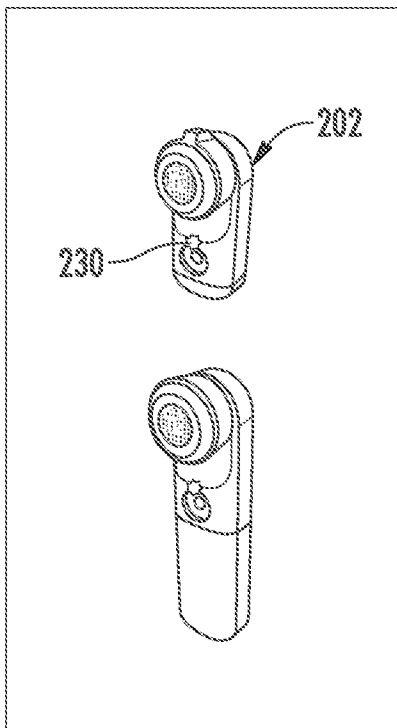

FIG. 54A

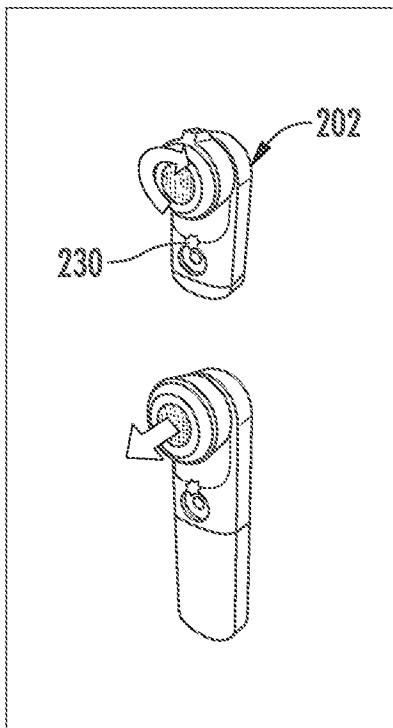

FIG. 54B

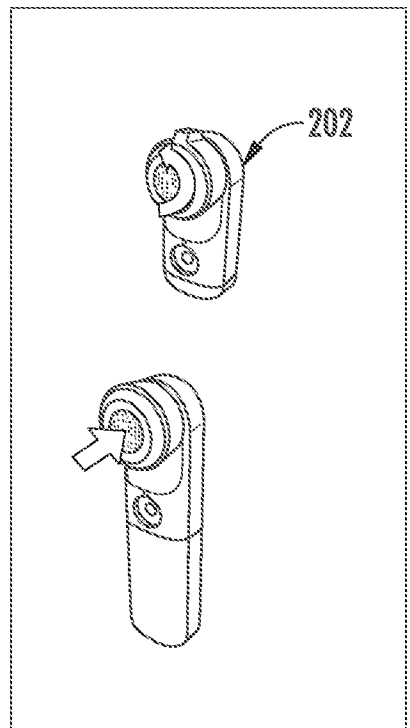

FIG. 54C

INTERNATIONAL SEARCH REPORT

International application No.

PCT/US 22/16082

A. CLASSIFICATION OF SUBJECT MATTER

IPC - E05B 47/00; A47F 1/04; A47F 5/00; A47F 1/00 (2022.01)

CPC - E05B 47/0009; A47F 1/04; A47F 5/0861; A47F 1/12; A47B 57/58; E05B 47/0001; E05B 73/00

According to International Patent Classification (IPC) or to both national classification and IPC

B. FIELDS SEARCHED

Minimum documentation searched (classification system followed by classification symbols)

See Search History document

Documentation searched other than minimum documentation to the extent that such documents are included in the fields searched

See Search History document

Electronic data base consulted during the international search (name of data base and, where practicable, search terms used)

See Search History document

C. DOCUMENTS CONSIDERED TO BE RELEVANT

Category*	Citation of document, with indication, where appropriate, of the relevant passages	Relevant to claim No.
D, X	WO 2020/227513 A1 (INVUE SECURITY PRODUCTS INC.) 12 November 2020 (12.11.2020) entire document, especially: fig 2, fig 30, fig 50; para: [0079]-[0081], [0084]-[0086], [0087], [0090], [0093], [0096], [00103], [00105], [00111], [00123], [00127]	1-25, 27-32
A	US 2013/0135263 A1 (OMURA) 30 May 2013 (30.05.2013) entire document	1-25, 27-32
A	US 2015/0077232 A1 (InVue Security Products Inc.) 19 March 2015 (19.03.2015) entire document	1-25, 27-32
A	US 9,298,954 B1 (Ewing) 29 March 2016 (29.03.2016) entire document	1-25, 27-32
A	US 2007/0159328 A1 (Belden et al.) 12 July 2007 (12.07.2007) entire document	1-25, 27-32

 Further documents are listed in the continuation of Box C. See patent family annex.

* Special categories of cited documents:

"A" document defining the general state of the art which is not considered to be of particular relevance

"D" document cited by the applicant in the international application

"E" earlier application or patent but published on or after the international filing date

"L" document which may throw doubts on priority claim(s) or which is cited to establish the publication date of another citation or other special reason (as specified)

"O" document referring to an oral disclosure, use, exhibition or other means

"P" document published prior to the international filing date but later than the priority date claimed

"T" later document published after the international filing date or priority date and not in conflict with the application but cited to understand the principle or theory underlying the invention

"X" document of particular relevance; the claimed invention cannot be considered novel or cannot be considered to involve an inventive step when the document is taken alone

"Y" document of particular relevance; the claimed invention cannot be considered to involve an inventive step when the document is combined with one or more other such documents, such combination being obvious to a person skilled in the art

"&" document member of the same patent family

Date of the actual completion of the international search

12 April 2022

Date of mailing of the international search report

APR 28 2022

Name and mailing address of the ISA/US

Mail Stop PCT, Attn: ISA/US, Commissioner for Patents
P.O. Box 1450, Alexandria, Virginia 22313-1450

Facsimile No. 571-273-8300

Authorized officer

Kari Rodriguez

Telephone No. PCT Helpdesk: 571-272-4300

INTERNATIONAL SEARCH REPORT

International application No.

PCT/US 22/16082

Box No. II Observations where certain claims were found unsearchable (Continuation of item 2 of first sheet)

This international search report has not been established in respect of certain claims under Article 17(2)(a) for the following reasons:

1. Claims Nos.:
because they relate to subject matter not required to be searched by this Authority, namely:

2. Claims Nos.:
because they relate to parts of the international application that do not comply with the prescribed requirements to such an extent that no meaningful international search can be carried out, specifically:

3. Claims Nos.: 26, 33
because they are dependent claims and are not drafted in accordance with the second and third sentences of Rule 6.4(a).

Box No. III Observations where unity of invention is lacking (Continuation of item 3 of first sheet)

This International Searching Authority found multiple inventions in this international application, as follows:

1. As all required additional search fees were timely paid by the applicant, this international search report covers all searchable claims.
2. As all searchable claims could be searched without effort justifying additional fees, this Authority did not invite payment of additional fees.
3. As only some of the required additional search fees were timely paid by the applicant, this international search report covers only those claims for which fees were paid, specifically claims Nos.:

4. No required additional search fees were timely paid by the applicant. Consequently, this international search report is restricted to the invention first mentioned in the claims; it is covered by claims Nos.:

Remark on Protest

- The additional search fees were accompanied by the applicant's protest and, where applicable, the payment of a protest fee.
- The additional search fees were accompanied by the applicant's protest but the applicable protest fee was not paid within the time limit specified in the invitation.
- No protest accompanied the payment of additional search fees