

(19)



Europäisches Patentamt  
European Patent Office  
Office européen des brevets



(11)

**EP 1 418 603 B1**

(12)

## EUROPEAN PATENT SPECIFICATION

(45) Date of publication and mention  
of the grant of the patent:  
**29.03.2006 Bulletin 2006/13**

(51) Int Cl.:  
**H01H 21/24<sup>(2006.01)</sup>**

(21) Application number: **03025671.3**

(22) Date of filing: **10.11.2003**

(54) **Switching device**

Schaltvorrichtung

Dispositif de commutation

(84) Designated Contracting States:  
**DE FR GB**

(30) Priority: **11.11.2002 JP 2002327212**

(43) Date of publication of application:  
**12.05.2004 Bulletin 2004/20**

(73) Proprietor: **ALPS ELECTRIC CO., LTD.**  
**Tokyo 145-8501 (JP)**

(72) Inventor: **Amano, Toshiaki,**  
**c/o Alps Electric Co., Ltd.**  
**Tokyo 145-8501 (JP)**

(74) Representative: **Klunker . Schmitt-Nilson . Hirsch**  
**Winzererstrasse 106**  
**80797 München (DE)**

(56) References cited:  
**GB-A- 828 875**                      **US-A- 2 757 252**  
**US-A- 4 803 316**

**EP 1 418 603 B1**

Note: Within nine months from the publication of the mention of the grant of the European patent, any person may give notice to the European Patent Office of opposition to the European patent granted. Notice of opposition shall be filed in a written reasoned statement. It shall not be deemed to have been filed until the opposition fee has been paid. (Art. 99(1) European Patent Convention).

## Description

**[0001]** The present invention relates to a switching device according to the preamble of claim 1.

**[0002]** A switching device of this type is known from US-A-4,803,316.

**[0003]** Various operation keys and a display unit are arranged on a front panel (control panel) of an on-vehicle electric appliance such as a car air conditioner and a car audio. These operation keys serve to actuate switching elements such as push switches provided at a rear face of the front panel, and, as shown in Fig. 7, conventional switching device has a structure wherein an operation key 1 having its upper end pivoted is pressed from the front so that a switching element 3 is press-driven via a driving rod 2 (see JP-A-2001-14978 (Fig. 2), for example).

**[0004]** In the conventional switching device shown in Fig. 7, an axis 1a is provided at the upper end of the operation key 1. Since the axis 1a is pivoted on a holding plate 4a of a supporting case 4, the operation key 1 is supported by the supporting case 4 in such a fashion that it rotates within the range of predetermined angles using the axis 1a as a rotation axis. The front panel 5 has an opening 5a for placing therein the operation key 1, and the operation key 1 moves backward (toward right side in the drawing) in the opening 5a when an operating force indicated by an arrow F is applied to the operation key 1 by pressing. A circuit substrate 6 is provided upright at a region on a rear face of the front panel 4, and a push type switching element 3 is mounted on the circuit substrate 6. The driving rod 2 is provided between a bottom end of the operation key 1 and the switching element 3, and the driving rod 2 moves toward the circuit substrate 6 when the operation key 1 is pressed.

**[0005]** Accordingly, it is possible to actuate the switching element 3 by pressing the operation key 1 to move the driving rod 2 by a predetermined stroke. Further, by releasing the operation force in such ON state, the operation key 1 is pressed back via the driving rod 2 by way of a self reset force of the switching element 3 returning to the OFF position, so that the operation key 1 automatically returns to the original non-operation position. In addition, a switching device having a structure wherein the front panel 5 rotatably supports the upper end of the operation key 1 in place of the supporting case 4 is known.

**[0006]** In the case of assembly of the conventional switching device described above, it is necessary to secure in the front panel 5 the opening 5a having a size similar to that of the operation key 1; however, because there has been a tendency toward an increase in size of the display unit and an increase in the number of operation keys in the front panel of the on-vehicle electric appliance due to the recent multifunctionalization, it is becoming difficult to provide the front panel 5 with many openings 5a for the operation keys 1. In the case of downsizing the front panel 5, it will be difficult to secure a sufficient number of openings 5a for the operation keys 1.

Of course, it is possible to use small size opening 5a if the operation key is reduced in size, but such downsizing is not preferred since it remarkably deteriorates the operability. In order to deal with the multifunctionalization of electric appliance and the downsizing of front panel, there has recently been a demand for a switching device having a novel structure wherein the openings for the operation keys to be provided in the front panel are downsized.

**[0007]** The present invention has been accomplished in view of the facts of the conventional technology, and an object thereof is to provide a switching device with good operability, which eliminates the need for securing a large opening for an operation key in the front panel.

**[0008]** As means for achieving the above object, a switching device according to the invention comprises the features of claim 1

**[0009]** In the thus-constituted switching device, the switching element is press-driven by way of the driving lever as the operation key projected forward from the front panel being pressed downward, thereby enabling to operate the operation key facing upward with the ease of operating a keyboard as well as to eliminate the need for providing the front panel with a large opening for the operation key.

**[0010]** In the switching device, by adapting an angle formed by a first straight line connecting a point of action of an operation force to the operation member to a center of rotation of the operation member and a second straight line connecting a point of action of an operation force to the switching element to the center of rotation to be increased at the time of operation, it is possible to dispose the operation key at a bottom end of a front face of the front panel at the same time with disposing the switching element at an arbitrary height of a rear face of the front panel; thereby eliminating the risk that the operation key will deteriorate a design and operability of the front panel and making it easier to dispose at a desired position the circuit substrate on which the switching element and the like are mounted.

**[0011]** For example, when the switching element is mounted on the circuit substrate which is held upright, it is possible to have other electric components which are mounted together with the switching element on an identical plane, such as a light source, faced to the front panel. Further, in this case, by setting a spacing between the driving lever and the circuit substrate to a value smaller than a radius of a rotation axis of the driving lever, even if the rotation axis tends to be disconnected from a bearing due to an excessive operation force or shock, it is possible to avoid the disconnection owing to the circuit substrate which controls positioning of the driving lever having the bearing. Therefore, improvements in assembly and a reduction in number of components are easily achieved since it is possible to attain sufficient assembly strength even by employing the simple attachment structure of snap-fitting the driving lever to the supporting member.

**[0012]** Further, in the switching device where the operation key projecting from the front face of the front panel is connected to a key holder supported rotatably as being disposed at the rear side (or rear face, respectively) of the front panel in the operation member and the key holder is engaged with the driving lever, the opening required on the front panel for the operation member can be significantly small since it is possible to connect the operation key to the key holder from the front and the rear of the front panel. An embodiment of the invention will be described with reference to the drawings wherein:

Fig. 1 is a sectional view showing a switching unit in which a switching device according to this embodiment is incorporated;

Fig. 2 is a broken perspective view showing the switching unit;

Fig. 3 is a diagram illustrating an operations of the switching device;

Fig. 4 is a sectional view showing the supporting device shown in Figs. 1 and 2;

Fig. 5 is a diagram showing a rear face of the front panel shown in Figs. 1 and 2;

Fig. 6 is a sectional view showing the front panel; and  
Fig. 7 shows a prior art switching unit.

**[0013]** A switching unit 10 shown in Figs. 1 and 2 is a part of an on-vehicle electric appliance and constituted essentially of a front panel 11, a plurality of switching devices 12 including a supporting case 13, a circuit substrate 14 on which a rubber sheet 22 is mounted, a connector 15, and a cover 16. Here, each of the switching devices 12 has an operation member 19 constituted of an operation key 17 and a key holder lever 18 coupled to the operation key 17, a driving lever 20 rotationally driven by the key holder lever 18, a pair of push type switching elements 21 press-driven by the driving lever 20, and the supporting case 13 rotatably supporting the key holder lever 18 and the driving lever 20, and the supporting case 13 is shared among the plurality of switching devices 12. The switching element 21 is a known one which has a movable contact portion 22b provided inside a click rubber 22a having the shape of a dome and projecting from the rubber sheet 22 and a fixed contact portion 14a provided on the circuit substrate 14, wherein the movable contact portion 22b and the fixed contact portion 14a face to each other as being connectable/disconnectable and the movable contact portion 22b is brought to contact with the fixed contact portion 14a when the click rubber 22a is pressed for a predetermined stroke to be buckled.

**[0014]** The front panel 11 is provided with a plurality of openings 11a in each of which a connecting shaft 17a of each of the operation keys 17 is placed and a plurality of display units 11b illuminated by light from a light emitting diode 23 mounted on the circuit substrate 14. A stiffening rib 11c is projected from the rear face of the front panel 11 as shown in Figs. 5 and 6. The front panel 11

is attached to a front end of the supporting case 13.

**[0015]** The operation key 17 is disposed at a front face of the front panel 11 with its pressed surface 17b being faced upward and is pressed downward. The connecting shaft 17a of the operation key 17 penetrates through the opening 11a of the front panel 11 to be press-fitted into a fitting hole 18a of the key holder lever 18. The connecting shaft 17a press-fitted into the fitting hole 18a is fixed to the key holder lever 18 with a fixing screw 24. Thus, the operation key 17 and the key holder lever 18 constituting the operation member 19 are connected to each other strongly. A mounting plate 18b is projected from each side of the key holder lever 18, and a hole 18c for inserting therein a boss 13b of the holding plate 13a projected from a front portion of the supporting case 13 is formed on each of the mounting plates 18b. Since the holding plate 13a has a flexibility in a direction of plate thickness, it is possible to achieve a state wherein the key holder lever 18 is rotatably supported by the supporting case 13 by thrusting the key holder lever 18 between a pair of the holding plates 13a facing to each other, whereby snapping the bosses 13b serving as rotation axes into the holes 18c at the time of assembly. The front panel 11 is attached to the supporting case 13 after thus snap-fitting the key holder lever 18 to the front portion of the supporting case 13, so that the stiffening rib 11c is disposed at a position controlling the flexibility of the holding plate 13a. A pair of engagement faces 18d on which projection pieces 20a of the driving lever 20 are mounted is provided respectively on shoulders of the key holder lever 18 sandwiching the fitting hole 18a.

**[0016]** Formed on each side of the driving lever 20 is the hole 20b into which the boss 13c projected from a rear portion of the supporting case 13 is inserted and a bearing 20c engaging with about a half of a periphery of the boss 13c as being adjacent to the hole 20b. It is possible to achieve a state wherein the driving lever 20 is engaged with the key holder lever 18 at the same time with being rotatably supported by the supporting case 13, by snapping the bosses 13c of the supporting case 13 into the holes 20b whereby mounting the projection pieces 20a on the engagement faces 18d of the key holder lever 18. The circuit substrate 14 on which the rubber sheet 22 is mounted is disposed at a position facing to a rear face of the driving lever 20 after thus snap-fitting the driving lever 20 to the rear portion of the supporting case 13, and a spacing  $d$  between the driving lever 20 and the circuit substrate 14 is so set as to be smaller than a radius  $r$  of the boss 13c serving as the rotation axis of the driving lever 20 as shown in Fig. 3. Thus, even when the driving lever 20 is positioned erroneously due to a large external force, it is possible to prevent such a positioning error that causes the boss 13c to come off from the bearing 20c thanks to the control by the circuit substrate 14. In addition, the upper end of the driving lever 20 serves as a presser 20d which is normally in contact with the top of the click rubber 22a.

**[0017]** The rear face of the circuit substrate 14 is sup-

ported by the cover 16, and the cover 16 is attached to the supporting case 13 as a back cover. The click rubber 22a of the rubber sheet 22 mounted on the circuit substrate 14 is incorporated in the presser 20d of the driving lever 20 with a pretension. The connector 15 is connected to the circuit substrate 14, and a cable 25 led from the connector 15 is extended outward from a rear face of the cover 16.

**[0018]** In the case of assembly of the thus-constituted switching unit 10, the connecting shaft 17a of the operation key 17 inserted into the opening 11a of the front panel 11 is pressed into the fitting hole 18a of the key holder lever 18, and then the fixing screw 24 is clamped to form the operation member 19 into an integrated body. Next, the boss 13b serving as the rotation axis is snapped into the hole 18c to rotatably attach the operation member 19 to the front portion of the supporting case 13. Then, the front panel 11 is attached to the front end of the supporting case 13. The boss 13c serving as rotation axis is snapped into the hole 20b to rotatably mount the driving lever 20 on the rear portion of the supporting case 13 as well as to mount the projection piece 20a of the driving lever 20 on the engagement face 18d of the key holder lever 18. The connector 15 is connected to the circuit substrate 14 on which the rubber sheet 22 is mounted so that the circuit substrate 14 is provided upright at the rear face of the driving lever 20, and then the cover 16 supporting the circuit substrate 14 and the connector 15 from their rear faces is attached to the supporting case 13 as the back cover, whereby finishing the assembly.

**[0019]** Hereinafter, an operation of the switching unit 10 will be described. In a non-operation state, the operation member 19 maintains the posture indicated by a solid line in Fig. 1 and the operation key 17 is positioned at the uppermost point within rotation range, since the projection piece 20a of the driving lever 20 presses the engagement face 18d of the key holder lever 18 downward owing to the pretension of the click rubber 22a.

**[0020]** In this state, when an operator presses the pressed surface 17b of the operation key 17 downward, the key holder lever 18 is rotationally driven via the connecting shaft 17a to rotate the operation member 19 in the anti-clock direction (in a direction of an arrow A in Fig. 3) with the boss 13b being used as the rotation axis, so that the engagement face 18d presses up the projection piece 20a to rotate the driving lever 20 in a direction of an arrow B, whereby the presser 20d presses the click rubber 22a. Then, when the operation key 17 is pressed down to the position indicated by a broken line in Fig. 1, the click rubber 22a is pressed by the presser 20d by the predetermined stroke to buckle, so that the movable contact portion 22b is brought into contact with the fixed contact portion 14a thereby to switch the state of the switching element 21 from OFF to ON.

**[0021]** More specifically, in the switching device 12 of this embodiment, an angle  $\alpha$  formed by a first straight line L1 connecting a point of action of the operation force to the operation member 19 to a center of rotation P of

the operation member 19 and a second straight line L2 connecting a point of action of the operation force to the switching element 21 to the center of rotation P is increased at the time of operation as shown in Fig. 3. In contrast, in the conventional switching device shown in Fig. 7, the angle  $\alpha$  is reduced at the time of operation. In other words, the switching device 12 of this embodiment has a structure wherein the pressed surface 17b of the operation key 17 moves away from the switching element 21 at the time of operation.

**[0022]** Further, when the operation force to the operation key 17 is released during the ON state, the shape of the click rubber 22a which has been buckled returns to the original dome shape, so that the movable contact portion 22b moves away from the fixed contact portion 14a to return the switching element 21 to the OFF state and that the projection piece 20a of the driving lever 20 is pressed back by the click rubber to press down the engagement face 18d of the key holder lever 18, thereby rotating the operation member 19 in the reverse direction to be returned automatically to the original non-operation position.

**[0023]** Thus, in the switching device 12 of this embodiment, since the operation key 17 projected from the front face of the front panel 11 is pressed downward to press-drive the switching element 21 by way of the driving lever 20, it is possible to operate the operation key 17 facing upward with the easiness of operating a keyboard. Further, since it is possible to maintain the size of the opening 11a for the operation member 19 required for the front panel 11 to be as small as to allow the elevation of the connecting shaft 17a, the front panel 11 affords a space to be easily adopted to multifunctionalization of an electric appliance, making it easy to achieve downsizing of the front panel 11 itself.

**[0024]** Also, since the switching device 12 has a structure wherein the pressed surface 17b of the operation key 17 moves away from the switching element 21 at the time of operation, it is possible to dispose the switching element 21 at an arbitrary height of the circuit substrate 14 provided upright behind the front panel 11 with the operation key 17 being disposed at the bottom end of the front face of the front panel 11. Therefore, the operation key 17 will not damage the design of the front panel 11, and it is possible to mount other electric components such as the light emitting diode 23 which is preferred to be disposed opposite to the front panel 11 at desired positions of the circuit substrate 14.

**[0025]** Further, since the spacing  $d$  between the driving lever 20 and the circuit substrate 14 is set to a value smaller than the radius  $r$  of the boss 13c which is the rotation axis of the driving lever 20 in this embodiment, even if the boss 13c tends to be disconnected from the bearing 20c due to an excessive operation force or shock, it is possible to avoid the disconnection owing to the circuit substrate 14 which controls positioning of the driving lever 20 having the bearing 20c. Therefore, advantages in improving the assembly and reducing the number of

components are derived since it is possible to achieve sufficient assembly strength at the same time with employing the simple attachment structure of snap-fitting the driving lever 20 to the rear portion of the supporting case 13.

**[0026]** Though the bosses 13b and 13c of the supporting case 13 are separately inserted into the hole 18c of the operation member 19 and the hole 20b of the driving lever 20 to serve as rotation axes in this embodiment, it is possible to provide the operation member 19 and the driving lever 20 with the rotation axes and to provide the supporting case 13 with the bearings. Also, though the switching device 12 in which two switching elements 21 are simultaneously actuated by one operation key 17 is described by way of example, it is possible to make correspondence between one operation key 17 and one or three or more switching elements 21; the structure of the switching element may be selected as required.

**[0027]** The present invention is carried out by way of the embodiment described above to achieve the following effects.

**[0028]** Since the operation key projected from the front face of the front panel is pressed downward to rotate the driving lever which press-drive the switching element by way of the driving lever in the switching device, it is possible to operate the operation key facing upward with the easiness of operating a keyboard. Further, there is no need for providing the front panel with a large opening for the operation key, and therefore the front panel 11 affords a space to be easily adopted to multifunctionalization of an electric appliance, making it easy to achieve downsizing of the front panel 11 itself.

**[0029]** Further, in the case where the spacing  $d$  between the driving lever and the circuit substrate is set to a value smaller than the radius  $r$  of the rotation axis of the driving lever, it is possible to avoid the rotation axis from being disconnected from the bearing even when the rotation axis tends to be disconnected from the bearing due to an excessive operation force or shock since positioning of the driving lever having the bearing or the rotation axis is controlled by the circuit substrate. Therefore, advantages in improving the assembly and reducing the number of components are readily derived since it is possible to achieve sufficient assembly strength even when the simple attachment structure of snap-fitting the driving lever to the supporting case is employed.

## Claims

1. A switching device comprising: an operation member (19) having an operation key (17) pressed downward for operation and disposed at a front side of a front panel (11); a driving lever (20) engaged with the operation member (19) and rotationally driven when the operation key is pressed; and a switching element (21) press-driven by the rotationally-driven driving lever, 20, **characterized in that** said opera-

tion member (19) is rotatably supported and that the switching element is mounted on a circuit substrate (127) held upright and that the front panel is provided with a display unit illuminated by light from a light emitting device (23) on the circuit substrate (14)

2. The switching device according to claim 1 (L1) **characterized in that** an angle made by a first straight line connecting a point of action of an operation force to the operation member (19) to a center (P) of rotation of the operation member (19) and a second straight line (L2) connecting a point of action of an operation force to the switching element (21) to said center of rotation of the operation member is increased at the time of operation.
3. The switching device— according to claim 2 **characterized in that** a spacing ( $d$ ) between the driving lever (20) and the circuit substrate (14) is set to a value smaller than a radius of a rotation axis of the driving lever (20).
4. The switching device according to any one of claims 1 to 3 **characterized in that** the operation member has a structure wherein the operation key (17) projecting frontward from the front panel (11) is connected to a key holder (18) supported rotatably as being disposed on a rear side of the front panel (11), the key holder being engaged with the driving lever (20).

## Patentansprüche

1. Schaltvorrichtung aufweisend:

ein Betätigungselement (19) mit einer Betätigungstaste (17), die zur Betätigung nach unten gedrückt wird und die an einer Vorderseite einer Frontplatte (11) angeordnet ist;  
einen Antriebshebel (20), der mit dem Betätigungselement (19) in Eingriff steht und bei Drücken der Betätigungstaste rotationsmäßig angetrieben wird;  
und ein Schaltelement (21), das durch den rotationsmäßig angetriebenen Antriebshebel (20) durch Druckbeaufschlagung betätigt wird,

**dadurch gekennzeichnet, dass** das Betätigungselement (19) drehbar gehalten ist und dass das Schaltelement an einem aufrecht angeordneten Schaltungssubstrat angebracht ist, und dass die Frontplatte mit einer Anzeigeeinheit versehen ist, die mit Licht von einer Licht-emittierenden Vorrichtung (23) auf dem Schaltungssubstrat (14) beleuchtet wird.

2. Schaltvorrichtung nach Anspruch 1, **dadurch gekennzeichnet, dass** ein Winkel, der ge-

bildet ist durch eine erste gerade Linie (L1), die einen Wirkungspunkt einer auf das Betätigungselement (19) ausgeübten Betätigungskraft mit einem Rotationszentrum (P) des Betätigungselements (19) verbindet, sowie durch eine zweite gerade Linie (L2), die einen Wirkungspunkt einer auf das Schaltelement (21) ausgeübten Betätigungskraft mit dem Rotationszentrum (P) des Betätigungselements verbindet, zum Zeitpunkt der Betätigung größer wird.

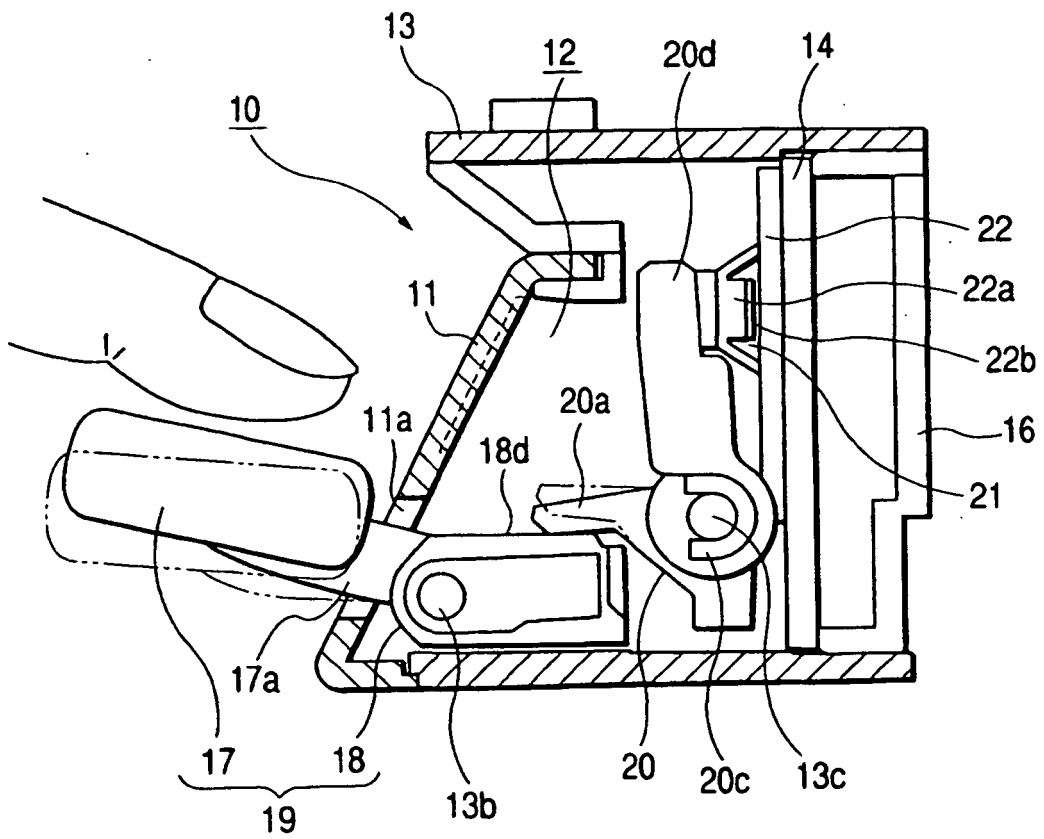
3. Schaltvorrichtung nach Anspruch 2, **dadurch gekennzeichnet, dass** ein Abstand (d) zwischen dem Antriebshebel (20) und dem Schaltungssubstrat (14) auf einen kleineren Wert gesetzt ist als ein Radius (r) einer Rotationsachse des Antriebshebels (20).
4. Schaltvorrichtung nach einem der Ansprüche 1 bis 3, **dadurch gekennzeichnet, dass** das Betätigungselement eine Konstruktion aufweist, bei der die von der Frontplatte (11) nach vorne wegstehende Betätigungstaste (17) mit einem Tastenhalter (18) verbunden ist, der drehbar gehalten ist und an einer Rückseite der Frontplatte (11) angeordnet ist, wobei der Tastenhalter mit dem Antriebshebel (20) in Eingriff steht.

3. Dispositif de commutation selon la revendication 2, **caractérisé en ce que** l'espacement (d) entre le levier d'entraînement (20) et le substrat de circuit (14) est fixé à une valeur plus petite que le rayon (r) de l'axe de rotation du levier d'entraînement (20).
4. Dispositif de commutation selon l'une quelconque des revendications 1 à 3, **caractérisé en ce que** l'élément d'actionnement a une structure dans laquelle la touche d'actionnement (17) faisant saillie vers l'avant depuis la façade avant (11) est connectée à un support de touche (18) supporté à rotation disposé sur le côté arrière de la façade avant (11), le support de touche étant en prise avec le levier d'entraînement (20).

## Revendications

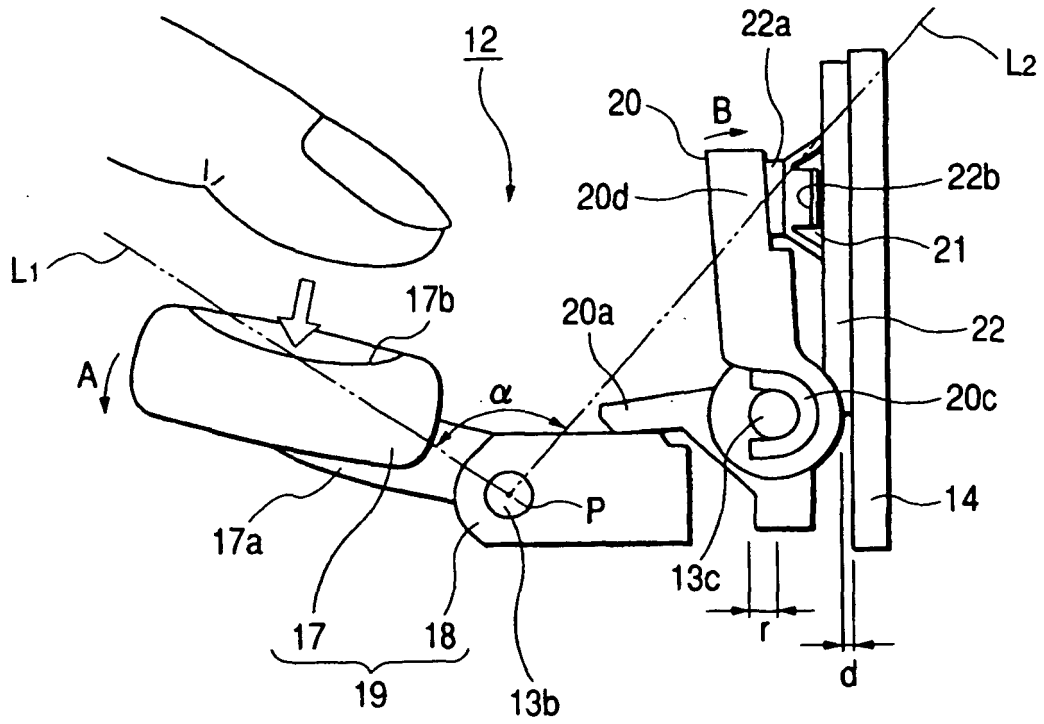
1. Dispositif de commutation comprenant : un élément d'actionnement (19) qui comporte une touche d'actionnement (17) que l'on presse vers le bas pour l'actionner et placé sur la face avant d'une façade avant (11); un levier d'entraînement (20) en prise avec l'élément d'actionnement (19) et entraîné en rotation lorsque la touche d'actionnement est actionnée ; et un élément de commutation (21) pressé par le levier d'entraînement entraîné en rotation (20), **caractérisé en ce que** ledit élément d'actionnement (19) est supporté à rotation et **en ce que** l'élément de commutation est monté sur un substrat de circuit (14) dressé debout, et **en ce que** la façade avant est pourvue d'une unité d'affichage éclairée par la lumière provenant d'un dispositif émetteur de lumière (23) sur le substrat de circuit (14).
2. Dispositif de commutation selon la revendication 1, **caractérisé en ce que** l'angle formé par une première ligne droite reliant un point d'action d'une force d'actionnement et l'élément d'actionnement (19) au centre de rotation (P) de l'élément d'actionnement (19) et une deuxième ligne droite reliant un point d'action d'une force d'actionnement à l'élément de commutation (21) audit centre de rotation (P) de l'élément d'actionnement est augmenté au moment de l'actionnement.

FIG. 1

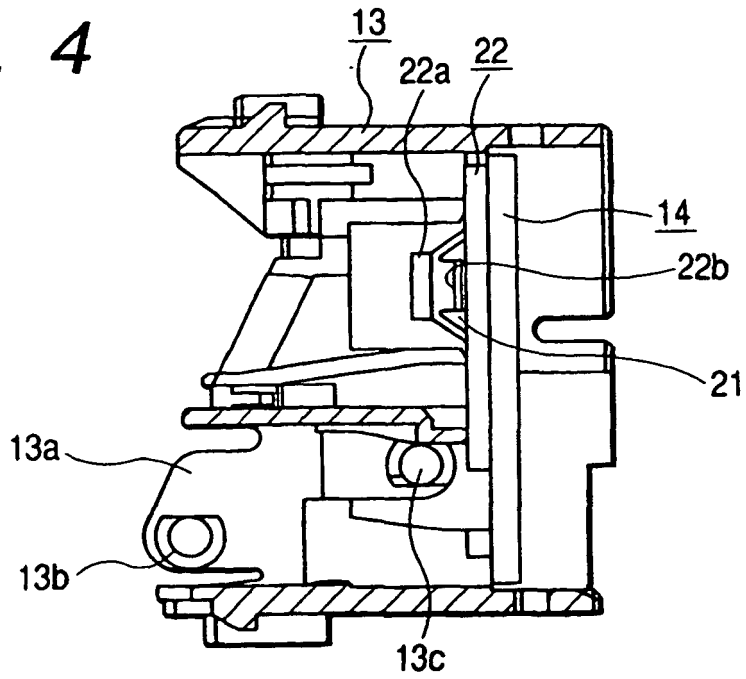




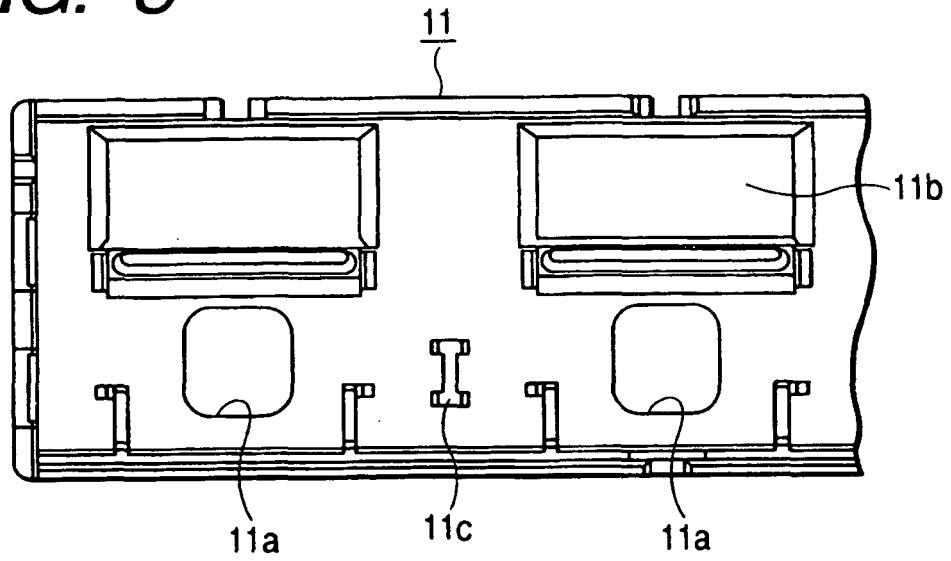
**FIG. 3**



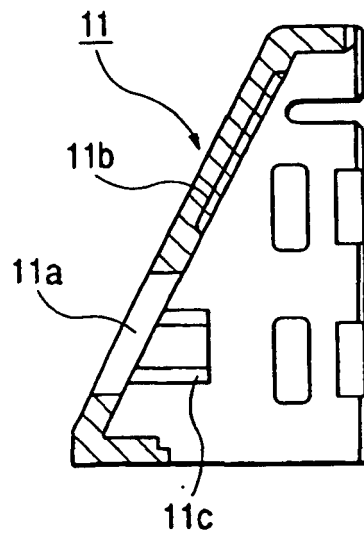
**FIG. 4**



**FIG. 5**



**FIG. 6**



**FIG. 7**  
**PRIOR ART**

