



## INTERNATIONAL APPLICATION PUBLISHED UNDER THE PATENT COOPERATION TREATY (PCT)

<p>(51) International Patent Classification <sup>6</sup> : <b>H04N 7/50, 7/26</b></p>	<p><b>A3</b></p>	<p>(11) International Publication Number: <b>WO 99/41912</b></p> <p>(43) International Publication Date: 19 August 1999 (19.08.99)</p>
<p>(21) International Application Number: PCT/IB99/00151</p> <p>(22) International Filing Date: 28 January 1999 (28.01.99)</p> <p>(30) Priority Data: 98200449.1 13 February 1998 (13.02.98) EP</p> <p>(71) Applicant: KONINKLIJKE PHILIPS ELECTRONICS N.V. [NL/NL]; Groenewoudseweg 1, NL-5621 BA Eindhoven (NL).</p> <p>(71) Applicant (for SE only): PHILIPS AB [SE/SE]; Kottbygatan 7, Kista, S-164 85 Stockholm (SE).</p> <p>(72) Inventors: KLEIHORST, Richard, P.; Prof. Holstlaan 6, NL-5656 AA Eindhoven (NL). CABRERA, Fabrice; Prof. Holstlaan 6, NL-5656 AA Eindhoven (NL).</p> <p>(74) Agent: SCHMITZ, Herman, J., R.; Prof. Holstlaan 6, NL-5656 AA Eindhoven (NL).</p>		<p>(81) Designated States: CN, JP, KR, European patent (AT, BE, CH, CY, DE, DK, ES, FI, FR, GB, GR, IE, IT, LU, MC, NL, PT, SE).</p> <p><b>Published</b> <i>With international search report. Before the expiration of the time limit for amending the claims and to be republished in the event of the receipt of amendments.</i></p> <p>(88) Date of publication of the international search report: 11 November 1999 (11.11.99)</p>

(54) Title: METHOD AND ARRANGEMENT FOR VIDEO CODING

(57) Abstract

A hybrid video encoder which carries out motion estimation and compensation (8) in the transform domain. In such an encoder, the calculation of a prediction block ( $\hat{Y}$ ) from previously encoded blocks ( $Z$ ) stored in the transform-domain frame memory (7) requires a large number of multiplications. This applies particularly to the motion estimation algorithm. In accordance with the invention, only a few DCT coefficients of candidate prediction blocks are calculated, for example, the DC coefficient and some AC coefficients. In a preferred embodiment, the AC coefficients are adaptively selected in dependence upon the motion vector which is being considered. The calculated coefficients of the candidate prediction blocks and the corresponding coefficients of the current input picture block ( $Y$ ) are then compared to identify the best-matching prediction block.

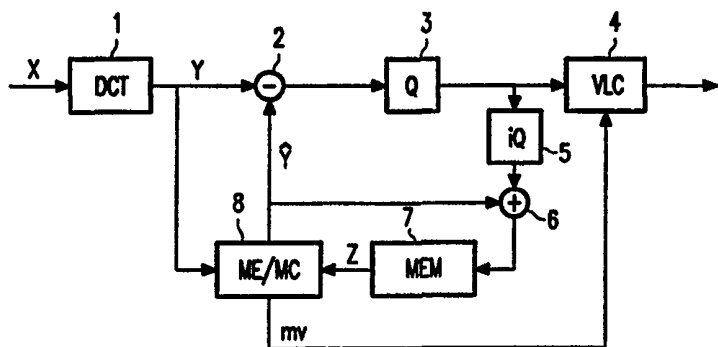

The calculated coefficients of the candidate prediction blocks and the corresponding coefficients of the current input picture block ( $Y$ ) are then compared to identify the best-matching prediction block.

**FOR THE PURPOSES OF INFORMATION ONLY**

Codes used to identify States party to the PCT on the front pages of pamphlets publishing international applications under the PCT.

AL	Albania	ES	Spain	LS	Lesotho	SI	Slovenia
AM	Armenia	FI	Finland	LT	Lithuania	SK	Slovakia
AT	Austria	FR	France	LU	Luxembourg	SN	Senegal
AU	Australia	GA	Gabon	LV	Latvia	SZ	Swaziland
AZ	Azerbaijan	GB	United Kingdom	MC	Monaco	TD	Chad
BA	Bosnia and Herzegovina	GE	Georgia	MD	Republic of Moldova	TG	Togo
BB	Barbados	GH	Ghana	MG	Madagascar	TJ	Tajikistan
BE	Belgium	GN	Guinea	MK	The former Yugoslav Republic of Macedonia	TM	Turkmenistan
BF	Burkina Faso	GR	Greece	ML	Mali	TR	Turkey
BG	Bulgaria	HU	Hungary	MN	Mongolia	TT	Trinidad and Tobago
BJ	Benin	IE	Ireland	MR	Mauritania	UA	Ukraine
BR	Brazil	IL	Israel	MW	Malawi	UG	Uganda
BY	Belarus	IS	Iceland	MX	Mexico	US	United States of America
CA	Canada	IT	Italy	NE	Niger	UZ	Uzbekistan
CF	Central African Republic	JP	Japan	NL	Netherlands	VN	Viet Nam
CG	Congo	KE	Kenya	NO	Norway	YU	Yugoslavia
CH	Switzerland	KG	Kyrgyzstan	NZ	New Zealand	ZW	Zimbabwe
CI	Côte d'Ivoire	KP	Democratic People's Republic of Korea	PL	Poland		
CM	Cameroon	KR	Republic of Korea	PT	Portugal		
CN	China	KZ	Kazakstan	RO	Romania		
CU	Cuba	LC	Saint Lucia	RU	Russian Federation		
CZ	Czech Republic	LI	Liechtenstein	SD	Sudan		
DE	Germany	LK	Sri Lanka	SE	Sweden		
DK	Denmark	LR	Liberia	SG	Singapore		
EE	Estonia						

## INTERNATIONAL SEARCH REPORT

International application No.

PCT/IB 99/00151

<b>A. CLASSIFICATION OF SUBJECT MATTER</b>			
<b>IPC6: H04N 7/50, H04N 7/26</b> According to International Patent Classification (IPC) or to both national classification and IPC			
<b>B. FIELDS SEARCHED</b>			
Minimum documentation searched (classification system followed by classification symbols)			
<b>IPC6: H04N</b>			
Documentation searched other than minimum documentation to the extent that such documents are included in the fields searched			
<b>SE,DK,FI,NO classes as above</b>			
Electronic data base consulted during the international search (name of data base and, where practicable, search terms used)			
<b>WPI</b>			
<b>C. DOCUMENTS CONSIDERED TO BE RELEVANT</b>			
Category*	Citation of document, with indication, where appropriate, of the relevant passages	Relevant to claim No.	
X	Mingzhou Song, Anni Cai, Member, IEEE and Jing-ao Sun, Member, IEEE, Motion Estimation in DCT Domain, International Conference on Communication Technology, Beijing, China, May 5-7, 1996, ISBN 0-7803-2916-3, page 671, column 1, line 7 - line 14; page 673, column 2, line 28 - line 34; figure 3, abstract	1,2,6,8	
Y	--	7	
A	--	3,4,5,	
Y	Gerard de Haan, Paul W.A.C. Biezen, Sub-pixel motion estimation with 3-D recursive search Block-matching, Signal Processing Image Communication 6 (1994) 229-239	7	
	--		
<input checked="" type="checkbox"/> Further documents are listed in the continuation of Box C. <input checked="" type="checkbox"/> See patent family annex.			
* Special categories of cited documents:			
"A"	document defining the general state of the art which is not considered to be of particular relevance	"I"	later document published after the international filing date or priority date and not in conflict with the application but cited to understand the principle or theory underlying the invention
"E"	earlier document but published on or after the international filing date	"X"	document of particular relevance: the claimed invention cannot be considered novel or cannot be considered to involve an inventive step when the document is taken alone
"L"	document which may throw doubts on priority claim(s) or which is cited to establish the publication date of another citation or other special reason (as specified)	"Y"	document of particular relevance: the claimed invention cannot be considered to involve an inventive step when the document is combined with one or more other such documents, such combination being obvious to a person skilled in the art
"O"	document referring to an oral disclosure, use, exhibition or other means	"&"	document member of the same patent family
"P"	document published prior to the international filing date but later than the priority date claimed		
Date of the actual completion of the international search	Date of mailing of the international search report		
<b>8 Sept 1999</b>	<b>13-09-1999</b>		
Name and mailing address of the ISA/ Swedish Patent Office Box 5055, S-102 42 STOCKHOLM Facsimile No. +46 8 666 02 86	Authorized officer  <b>Michel Gascoin/cs</b> Telephone No. +46 8 782 25 00		

## INTERNATIONAL SEARCH REPORT

International application No.

PCT/IB 99/00151

C (Continuation). DOCUMENTS CONSIDERED TO BE RELEVANT		
Category*	Citation of document, with indication, where appropriate, of the relevant passages	Relevant to claim No.
A	US 4245248 A (ARUN N. NETRAVALI ET AL), 13 January 1981 (13.01.81), see the whole document  --	1-8
A	US 5408274 A (SHIH-FU CHANG ET AL), 18 April 1995 (18.04.95), see the whole document  --	1-8
A	US 4704628 A (WEN-HSIUNG CHEN ET AL), 3 November 1987 (03.11.87), see the whole document  --	1-8
E	WO 9926418 A1 (A & T TECHNOLOGIES GROUP), 27 May 1999 (27.05.99), see the whole document  -- -----	1-8

**INTERNATIONAL SEARCH REPORT**

Information on patent family members

02/08/99

International application No.

PCT/IB 99/00151

Patent document cited in search report	Publication date	Patent family member(s)	Publication date
US 4245248 A	13/01/81	NONE	
US 5408274 A	18/04/95	AU 6395594 A WO 9421079 A	26/09/94 15/09/94
US 4704628 A	03/11/87	NONE	
WO 9926418 A1	27/05/99	NONE	