



(12) **EUROPEAN PATENT APPLICATION**

- (43) Date of publication: **01.06.2022 Bulletin 2022/22**
- (51) International Patent Classification (IPC): **B65B 11/02 (2006.01)**
- (21) Application number: **21203470.6**
- (52) Cooperative Patent Classification (CPC): **B65B 11/02; B65B 11/025**
- (22) Date of filing: **19.10.2021**

- |   |   |
|---|---|
| <p>(84) Designated Contracting States:<br/> <b>AL AT BE BG CH CY CZ DE DK EE ES FI FR GB GR HR HU IE IS IT LI LT LU LV MC MK MT NL NO PL PT RO RS SE SI SK SM TR</b><br/>         Designated Extension States:<br/> <b>BA ME</b><br/>         Designated Validation States:<br/> <b>KH MA MD TN</b></p> <p>(30) Priority: <b>30.11.2020 US 202017106622</b></p> <p>(71) Applicant: <b>Cousins Packaging Inc. Mississauga, ON L4V 1H9 (CA)</b></p> | <p>(72) Inventors:<br/> <ul style="list-style-type: none"> <li>• <b>Cousins, Neil. G. Tottenham, Ontario, L0G 1W0 (CA)</b></li> <li>• <b>Davidovic, Srbislav Z. Oakville, Ontario, L6J 7P1 (CA)</b></li> </ul> </p> <p>(74) Representative: <b>Patentanwälte Ruff, Wilhelm, Beier, Dauster &amp; Partner mbB Kronenstraße 30 70174 Stuttgart (DE)</b></p> |
|---|---|

(54) **STRECH WRAP FILM CARRIAGE**

(57) **ABSTRACT OF THE DISCLOSURE**

A carriage for a stretch wrap assembly including a base, a top housing, and a pre-stretch assembly. A bot-

tom portion of the film is formed into a roped or creased portion between an area wherein the film leaves a roll of stretch wrap and the pre-stretch assembly.

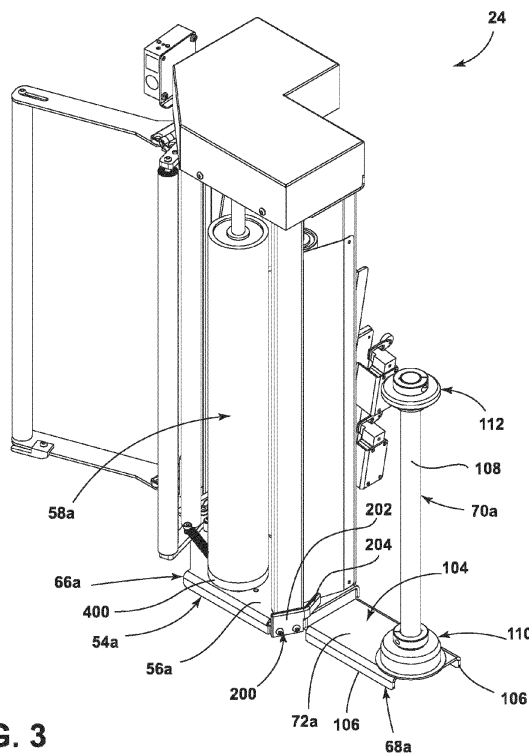

**FIG. 3**

## Description

### FIELD OF THE INVENTION

**[0001]** The present invention concerns stretch wrapping machines, and more particularly relates to a carriage for a stretch wrapping machine.

### BACKGROUND OF THE INVENTION

**[0002]** During the past several decades, considerable developments have been made in the field of wrapping a load with a stretched web of film. Most notably, the film web dispenser used in stretch wrapping operations has developed to the extent that it contains a series of rollers which defines a path through which the web passes so that it can be pre-stretched prior to being dispensed on the load. However, those in the field are continuously looking for means for forming a better wrap about a product.

### SUMMARY OF THE INVENTION

**[0003]** An aspect of the present invention is to provide a carriage for a stretch wrap assembly comprising a base, a top housing, a pre-stretch assembly located between the base and the top housing, with the pre-stretch assembly including a plurality of pre-stretch rollers, and a gear system located for rotating the pre-stretch rollers at a desired relative speed for stretching stretch wrap passing through the pre-stretch assembly. The base has a top surface and the plurality of pre-stretch rollers extending substantially perpendicularly from the top surface such that axes of rotation of the plurality of pre-stretch rollers are substantially perpendicular to the top surface. The base further includes a source of stretch wrap extension platform extending laterally from a main portion of the base, with the source of stretch wrap extension platform not being located under the top housing. The source of stretch wrap extension platform has an upper surface and a mandrel extending substantially perpendicularly from the upper surface. The mandrel is configured to receive a roll of stretch wrap film thereon such that an axis of rotation of the roll of stretch wrap film is substantially perpendicular to the upper surface of the source of stretch wrap extension platform. The upper surface of the source of stretch wrap extension platform is located below the top surface of the base such that a bottom of the roll of stretch wrap film can be located below a bottom of the plurality of pre-stretch rollers.

**[0004]** Another aspect of the present invention is to provide a carriage for a stretch wrap assembly comprising a base, a top housing, a pre-stretch assembly located between the base and the top housing, with the pre-stretch assembly including a plurality of pre-stretch rollers, and a gear system located for rotating the pre-stretch rollers at a desired relative speed for stretching stretch wrap film passing through the pre-stretch assembly. The

base has a top surface and the plurality of pre-stretch rollers extending substantially perpendicularly from the top surface such that axes of rotation of the plurality of pre-stretch rollers are substantially perpendicular to the top surface. The base further includes a source of stretch wrap extension platform extending laterally from a main portion of the base. The source of stretch wrap extension platform has a mandrel extending substantially perpendicularly from an upper surface thereof, with the mandrel configured to receive a roll of stretch wrap film thereon such that an axis of rotation of the roll of stretch wrap film is substantially perpendicular to the upper surface of the source of stretch wrap extension platform. The carriage further includes a roping bar located between the mandrel and the pre-stretch assembly, the roping bar being configured to such that a bottom of the film extending between the roll of stretch wrap film and the pre-stretch assembly forces the bottom upward to form the film into a bottom roping portion before the film enters the pre-stretch assembly.

**[0005]** Yet another aspect of the present invention is to provide a method of roping at least a portion of stretch wrap film, the method comprising providing a carriage having a base, a top housing, and a pre-stretch assembly located between the base and the top housing; placing a roll of stretch wrap film on the base; pulling film from the roll of stretch wrap film through the carriage; pre-stretching the film passing through the carriage with the pre-stretch assembly; and roping at least a bottom portion of the film from the roll of stretch wrap at a location between the roll of stretch wrap and the pre-stretch assembly.

**[0006]** Further aspects of the present invention follow from the claims and the detailed description of the preferred embodiment.

### BRIEF DESCRIPTION OF THE DRAWINGS

#### **[0007]**

FIG. 1 is a side view of a wrap machine of the present invention.

FIG. 2 is a side view of a prior art carriage of a prior art wrap machine.

FIG. 3 is a perspective view of a carriage of the present invention.

FIG. 4 is a front view of the carriage of the present invention.

FIG. 5 is a side view of the carriage of the present invention.

FIG. 6 is a front view of the carriage of the present invention forming a roped or creased area on film.

FIG. 7 is a front view of the carriage of the present invention with a support block to prevent forming the roped or creased area on the film.

FIG. 8 is a front view of the carriage of the present invention on a support column.

## DETAILED DESCRIPTION OF THE PREFERRED EMBODIMENT

**[0008]** For purposes of description herein, the terms "upper," "lower," "right," "left," "rear," "front," "vertical," "horizontal," and derivatives thereof shall relate to the invention as orientated in FIG. 1. However, it is to be understood that the invention may assume various alternative orientations, except where expressly specified to the contrary. It is also to be understood that the specific devices and processes illustrated in the attached drawings, and described in the following specification are simply exemplary embodiments of the inventive concepts. Hence, specific dimensions and other physical characteristics relating to the embodiments disclosed herein are not to be considered as limiting.

**[0009]** The reference number 10 (FIG. 1) generally designates a wrap machine of the present invention. The wrap machine 10 includes a base 14 having a rotatable arm 12 connected thereto. The wrap machine 10 further includes a carriage 24 vertically movable on the rotatable arm 12 for wrapping a product 28 on a pallet 32 located on the ground 30. The carriage 24 carries a roll of stretch wrap film 26a for wrapping the product 28 and could also be used for wrapping an upper end of the pallet 32. The present invention is drawn to the carriage 24, which can be used on any wrap machine 10, including a portable wrap machine as shown. An example of a portable wrap machine is disclosed in U.S. Patent Application No. 16/569 170 entitled PORTABLE WRAPPING MACHINE, the entire contents of which are incorporated herein by reference. In the portable wrap machine, the base 14 is movable and carriage 24 is moved about the product on the rotatable arm 12. It is contemplated that the carriage 24 as disclosed herein can also be used in a wrap machine that does not have a movable base such that the product is moved to adjacent the base and the rotatable arm and carriage is rotated about the product to wrap the product. Such stationary wrap machines are well known to those skilled in the art. Furthermore, it is contemplated that the carriage 24 as disclosed herein can be used with a wrap machine that includes a stationary column that has a carriage movable vertically thereon wherein the product is turned on a turntable to wrap the product. Such wrap machines with turntables are well known to those skilled in the art. An example of a stationary wrap machine with a turntable is disclosed in U.S. Patent No. 8 166 732 entitled STRETCH WRAP MACHINE WITH TOP CORNER FILM TRANSFER, the entire contents of which are incorporated herein by reference.

**[0010]** FIG. 2 illustrates a prior art carriage 50. The prior art carriage 50 includes a top support 52 and a base 54 having a main portion 66 with an upper surface 56. The prior art carriage 50 includes a pre-stretch assembly 58 including a plurality of rollers extending between the base 54 and the top support 52, including pre-stretch rollers 60, a diverter roller 62, a dancer roller 64, nip rollers (not shown) for holding film against the pre-stretch rollers

60 and idle rollers (not shown). Such pre-stretch assembly 58, pre-stretch rollers 60, the diverter roller 62, the dancer roller 64, the nip rollers and the idle rollers and their function are well known to those skilled in the art.

5 The base 54 includes the main portion 66 supporting the pre-stretch assembly 58 and a source of stretch wrap extension platform 68 extending laterally from the main portion 66 of the base 54. The source of stretch wrap extension platform 68 includes a stretch wrap mandrel 70 extending upward vertically from an upper surface 72 of the source of stretch wrap extension platform 68 of the base 54. In the prior art carriage 50, the upper surface 56 of the main portion 66 and the upper surface 72 of the source of stretch wrap extension platform 68 are level and contiguous.

10  
15  
20  
25  
30  
35  
**[0011]** A roll of stretch wrap film 26 (shown in phantom in FIG. 2) comprising film 76 wrapped about a center tube 78 is inserted over the stretch wrap mandrel 70 with the mandrel 70 closely fitting within the tube 78 of the roll of stretch wrap film 26. The roll of stretch wrap film 26 comes to rest on the upper surface 72 of the source of stretch wrap extension platform 68 of the base 54. During use, the film 76 of the roll of stretch wrap film 26 unrolls from the center tube 78 and is threaded through the pre-stretch assembly 58 to stretch the film 76 before the film 76 is wrapped about the product 28. The pre-stretch assembly 58 also includes a gear system (not shown in FIG. 2) that connects to the pre-stretch rollers 60 and an endless link connected to the gear system that rotates the pre-stretch rollers 60 at different speeds and/or the pre-stretch rollers 60 have different diameters to stretch the film in a manner well known to those skilled in the art. An example of a prior art carriage is disclosed in U.S. Patent No. 7 908 830 entitled CARRIAGE FOR A STRETCH WRAPPING MACHINE, the entire contents of which are incorporated herein by reference.

40  
45  
50  
**[0012]** In the prior art carriage 50, the upper surface 56 of the main portion 66 and the upper surface 72 of the source of stretch wrap extension platform 68 are level and contiguous such that the base 54 supports both the stretch wrap mandrel 70, the pre-stretch rollers 60 and the remaining rollers on a level plane. The center tube 78 along with the film 76 thereon of the roll of stretch wrap film 26 also rest on the upper surface 72 of the source of stretch wrap extension platform 68 of the base 54. Therefore, the film 76 from the roll of stretch wrap film 26 that enters the pre-stretch assembly 58 of the prior art carriage 50 is substantially parallel to the axes of rotation of the rollers of the pre-stretch assembly 58 and is flat without any creases.

55  
**[0013]** In the illustrated example, the carriage 24 of the present invention (FIGS. 3-7) is substantially identical to the prior art carriage 50. In FIGS. 3-7, identical parts from the prior art carriage 50 included in the carriage 24 of the present invention are represented by the same, corresponding reference number, except for the suffix "a" in the numerals of the FIGS. 3-7. The carriage 24 of the present invention allows for roping of a bottom portion

100 of the film 76a from the roll of stretch wrap film 26a that enters the pre-stretch assembly 58a, thereby creating a roped or creased area 102 at the bottom portion 100 of the film 76a (see FIG. 6).

**[0014]** The illustrated carriage 24 of the present invention can provide for the roped or creased area 102 at the bottom portion 100 of the film 76a in several manners. For example, the upper surface 72a of the source of stretch wrap extension platform 68a can be located below the upper surface 56a of the main portion 66a of the base 54a having the pre-stretch assembly 58a. Alternatively, the carriage 24 can include a film bottom roping bar 200 that engages the bottom portion 100 of the film 76a from the roll of stretch wrap film 26a before the film 76a enters the pre-stretch assembly 58a. Moreover, it is contemplated that the carriage 24 could include both the upper surface 72a of the source of stretch wrap extension platform 68a being lower than the upper surface 56a of the main portion 66a of the base 54a and the film bottom roping bar 200.

**[0015]** The illustrated source of stretch wrap extension platform 68a of the base 54a includes a stretch wrap mandrel 70a for holding the roll of stretch wrap film 26a (see FIG. 6). In one embodiment, the source of stretch wrap extension platform 68a can be any platform wherein the bottom of the film 76a leaving the roll of stretch wrap film 26a is located below the upper surface 56a of the main portion 66a of the base 54a. As shown in FIGS. 3-7, the source of stretch wrap extension platform 68a includes a plate 104 having the upper surface 72a. The plate 104 can be connected or formed from the base 54a of the carriage 24a and is configured such that the upper surface 72a is located below the upper surface 56a of the main portion 66a of the base 54a. The plate 104 can include strengthening flanges 106 extending downwardly from the edges of the plate 104 for strength.

**[0016]** In the illustrated example, the stretch wrap mandrel 70a extends upward and perpendicularly from the plate 104 and is configured to hold the roll of stretch wrap film 26a thereon. The stretch wrap mandrel 70a includes a fixed post 108, a bottom wheel 110 and a top wheel 112. The bottom wheel 110 and the top wheel 112 are rotatable upon the fixed post 108. The bottom wheel 110 and the top wheel 112 have approximately the same diameter and are configured to closely receive the center tube 78a of the roll of stretch wrap film 26a to allow the roll of stretch wrap film 26a to easily rotate.

**[0017]** The source of stretch wrap extension platform 68a of the base 54a having the upper surface 72a being lower than the upper surface 56a of the main portion 66a of the base 54a allows the bottom portion 100 of the film 76a to form the roped or creased area 102 as shown in FIG. 6. As shown in FIG. 6, when the roll of stretch wrap film 26a is fully inserted onto the stretch wrap mandrel 70a, the bottom portion 100 of the film 76a on the center tube 78 is directly adjacent or abutting the upper surface 72a of the source of stretch wrap extension platform 68a of the base 54a. As the film 76a is pulled from the center

tube 78 to move through the pre-stretch assembly 58a to stretch the film 76a as outlined above employing the pre-stretch rollers 60a and a gear system 114, the bottom portion 100 of the film 76a is moved upward to move over the upper surface 56a of the main portion 66a of the base 54a, thereby forming the roped or creased area 102.

**[0018]** It is contemplated that the bottom portion 100 of the film 76a could abut any surface between the upper surface 72a of the source of stretch wrap extension platform 68a of the base 54a and the upper surface 56a of the main portion 66a of the base 54a. For example, such surface could be merely a ledge between the two upper surfaces 56a, 72a. The surface could also be on the film bottom roping bar 200. The film bottom roping bar 200 (see FIG. 3) includes a primary plate portion 202 connected to the base 54a and an arm 204 that extends directly in the path between the roll of stretch wrap film 26a and the pre-stretch assembly 58a such that the bottom portion 100 of the film 76a is forced to form the roped or creased area 102. It is contemplated that the arm 204 can be stationary (as shown) or can be pivotally connected to the primary plate portion 202 (and can have, for example, a circular cross-sectional shape (i.e., a roller)).

**[0019]** It is contemplated that the film bottom roping bar 200 could be the sole mechanism for forming the roped or creased area 102. For example, if the upper surface 72a of the source of stretch wrap extension platform 68a of the base 54a and the upper surface 56a of the main portion 66a of the base 54a were level, the arm 204 of the film bottom roping bar 200 could force the bottom portion 100 of the film 76a upward to form the roped or creased area 102. It is further contemplated that the film bottom roping bar 200 could be made to be easily removable (e.g., through a wing nut connection) or could be made to be vertically adjustable to control the amount of the bottom portion 100 of the film 76a that is made into the roped or creased area 102. Alternatively, it is contemplated that the source of stretch wrap extension platform 68a of the base 54a could be configured to be vertically adjustably connected to the main portion 66 of the base 54a to control the amount of the bottom portion 100 of the film 76a that is made into the roped or creased area 102.

**[0020]** FIG. 7 illustrates a system for not forming the roped or creased area 102 when the film bottom roping bar 200 and/or the unlevel surfaces 56a, 72a are employed. As shown in FIG. 7, a support disc 300 can be placed over the mandrel 70a before the roll of stretch wrap film 26a is over the mandrel 70a. The support disc 300 supports the center tube 78a and the rest of the roll of stretch wrap film 26a above the upper surface 72a of the source of stretch wrap extension platform 68a of the base 54a. Therefore, the bottom portion 100 of the film 76 does not form the roped or creased area 102 before entering the pre-stretch assembly 58a. The support disc 300 can be a closed ring inserted over the mandrel 70a, donut shaped to be allowed to be slid laterally onto the mandrel 70a (or selectively removed or added, for exam-

ple, after the wrapping of the product has begun). It is further contemplated that the support disc 300 could be recessed into the source of stretch wrap extension platform 68a and either manually or automatically raised and lowered.

**[0021]** When using the carriage 24 as disclosed herein, there can be further modifications. For example, as illustrated in FIG. 3-5, the pre-stretch rollers 60a can include a cylindrical lower area 400 that is harder than the remaining portion of the pre-stretch rollers 60a and having the same diameter to ensure that the rope portion 102 of the film 76a does not permanently indent the grip face of the pre-stretch rollers 60a. For example, the lower area 400 can be made of metal (e.g., aluminum). Furthermore, a shown in FIG. 8, the carriage 24 can be tilted relative to the rotatable arm 12 and a ground surface 500 such that a dancer roller 502 (the last roller before the film 76a leaves the carriage 24) is closer to the ground 500 than the source of stretch wrap extension platform 68. With such tilt, the rope portion 102 can be wrapped about a product very close to the ground 500 and, if used, about a pallet holding the goods to be wrapped. The tilt also allows the source of stretch wrap extension platform 68 to be lower than the main portion 66a of the base 54a as outlined above.

**[0022]** The above description is considered that of the one embodiment only. Modification of the invention will occur to those skilled in the art and to those who make or use the invention. Therefore, it is understood that the embodiment shown in the drawings and described above is merely for illustrative purposes and not intended to limit the scope of the invention.

## Claims

1. A carriage (24) for a stretch wrap assembly comprising:

a base (54a);  
 a top housing;  
 a pre-stretch assembly (58a) located between the base (54a) and the top housing, the pre-stretch assembly (58a) including a plurality of pre-stretch rollers (60a); and  
 a gear system (114) located for rotating the pre-stretch rollers (60a) at a desired relative speed for stretching stretch wrap film (26a) passing through the pre-stretch assembly (58a);  
 the base (54a) having a top surface (56a) and the plurality of pre-stretch rollers (60a) extending substantially perpendicularly from the top surface (56a) such that axes of rotation of the plurality of pre-stretch rollers (60a) are substantially perpendicular to the top surface (56a);  
**characterized in that** the base (54a) further includes a source of stretch wrap extension platform (68a) extending laterally from a main por-

tion (66a) of the base (54a), the source of stretch wrap extension platform (68a) not being located under the top housing;

the source of stretch wrap extension platform (68a) having an upper surface (72a) and a mandrel (70a) extending substantially perpendicularly from the upper surface (72a), the mandrel (70a) configured to receive a roll of stretch wrap film (26a) thereon such that an axis of rotation of the roll of stretch wrap film (26a) is substantially perpendicular to the upper surface (72a) of the source of stretch wrap extension platform (68a);

wherein the upper surface (72a) of the source of stretch wrap extension platform (68a) is located below the top surface (56a) of the base (54a) such that a bottom of the roll of stretch wrap film (26a) can be located below a bottom of the plurality of pre-stretch rollers (60a).

2. A carriage (24) according to Claim 1, further including:

a roping bar (200) located between the mandrel (70a) and the pre-stretch assembly (58a), the roping bar (200) being configured to such that the bottom of the film extending between the roll of stretch wrap film (26a) and the pre-stretch assembly (58a) forces the bottom upward to form the film into a bottom roping portion before the film enters the pre-stretch assembly (58a).

3. A carriage (24) according to Claim 1 or 2, wherein: the pre-stretch rollers (60a) include a cylindrical lower area (400) that is harder than the remaining portion of the pre-stretch rollers (60a) and having the same diameter.

4. A carriage (24) according to Claim 3, wherein: the cylindrical lower area (400) includes a cylindrical aluminum surface.

5. A carriage (24) for a stretch wrap assembly comprising:

a base (54a);  
 a top housing;  
 a pre-stretch assembly (58a) located between the base (54a) and the top housing, the pre-stretch assembly (58a) including a plurality of pre-stretch rollers (60a);  
 a gear system (114) located for rotating the pre-stretch rollers (60a) at a desired relative speed for stretching stretch wrap film (26a) passing through the pre-stretch assembly (58a);  
 the base (54a) having a top surface (56a) and the plurality of pre-stretch rollers (60a) extending substantially perpendicularly from the top surface (56a) such that axes of rotation of the

plurality of pre-stretch rollers (60a) are substantially perpendicular to the top surface (56a);  
**characterized in that** the base (54a) further includes a source of stretch wrap extension platform (68a) extending laterally from a main portion (66a) of the base (54a);  
 the source of stretch wrap extension platform (68a) having a mandrel (70a) extending substantially perpendicularly from an upper surface (72a) thereof, the mandrel (70a) configured to receive a roll of stretch wrap film (26a) thereon such that an axis of rotation of the roll of stretch wrap film (26a) is substantially perpendicular to the upper surface (72a) of the source of stretch wrap extension platform (68a); and  
 a roping bar (200) located between the mandrel (70a) and the pre-stretch assembly (58a), the roping bar (200) being configured to such that a bottom (100) of the film extending between the roll of stretch wrap film (26a) and the pre-stretch assembly (58a) forces the bottom (100) upward to form the film into a bottom roping portion (102) before the film enters the pre-stretch assembly (58a).

6. A carriage (24) according to Claim 5, wherein: the pre-stretch rollers (60a) include a cylindrical lower area (400) that is harder than the remaining portion of the pre-stretch rollers (60a) and having the same diameter.

7. A carriage (24) according to Claim 6, wherein: the cylindrical lower area (400) includes a cylindrical aluminum surface.

8. A method of roping at least a portion of stretch wrap film (26a), the method comprising:

providing a carriage (24) having a base (54a), a top housing, and a pre-stretch assembly (58a) located between the base (54a) and the top housing;  
 placing a roll of stretch wrap film (26a) on the base (54a);  
 pulling film from the roll of stretch wrap film (26a) through the carriage (24);  
 pre-stretching the film passing through the carriage (24) with the pre-stretch assembly (58a);  
 and  
 roping at least a bottom (100) of the film from the roll of stretch wrap film (26a) at a location between the roll of stretch wrap film (26a) and the pre-stretch assembly (58a).

9. A method according to Claim 8, further including: locating a roping bar (200) between a mandrel (70a) and the pre-stretch assembly (58a), the roping bar (200) forcing the bottom (100) upward to form the

film into a bottom roping portion (102) before the film enters the pre-stretch assembly (58a).

10. A method according to Claim 8 or 9, wherein: the pre-stretch assembly (58a) includes pre-stretch rollers (60a) having a cylindrical lower area (400) that is harder than the remaining portion of the pre-stretch rollers (60a) and having the same diameter.

11. A method according to Claim 10, wherein: the cylindrical lower area (400) includes a cylindrical aluminum surface.

5

10

15

20

25

30

35

40

45

50

55

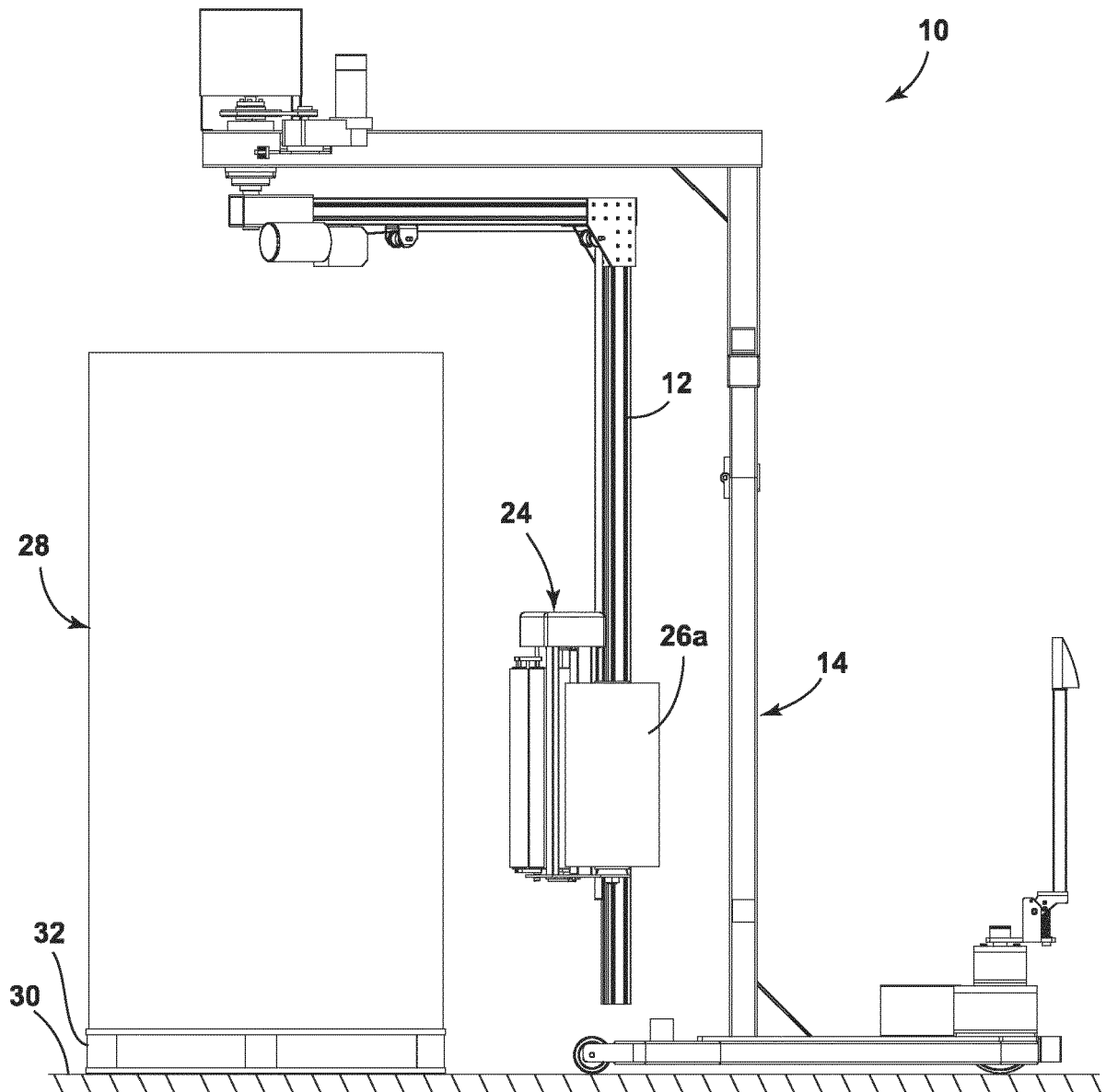
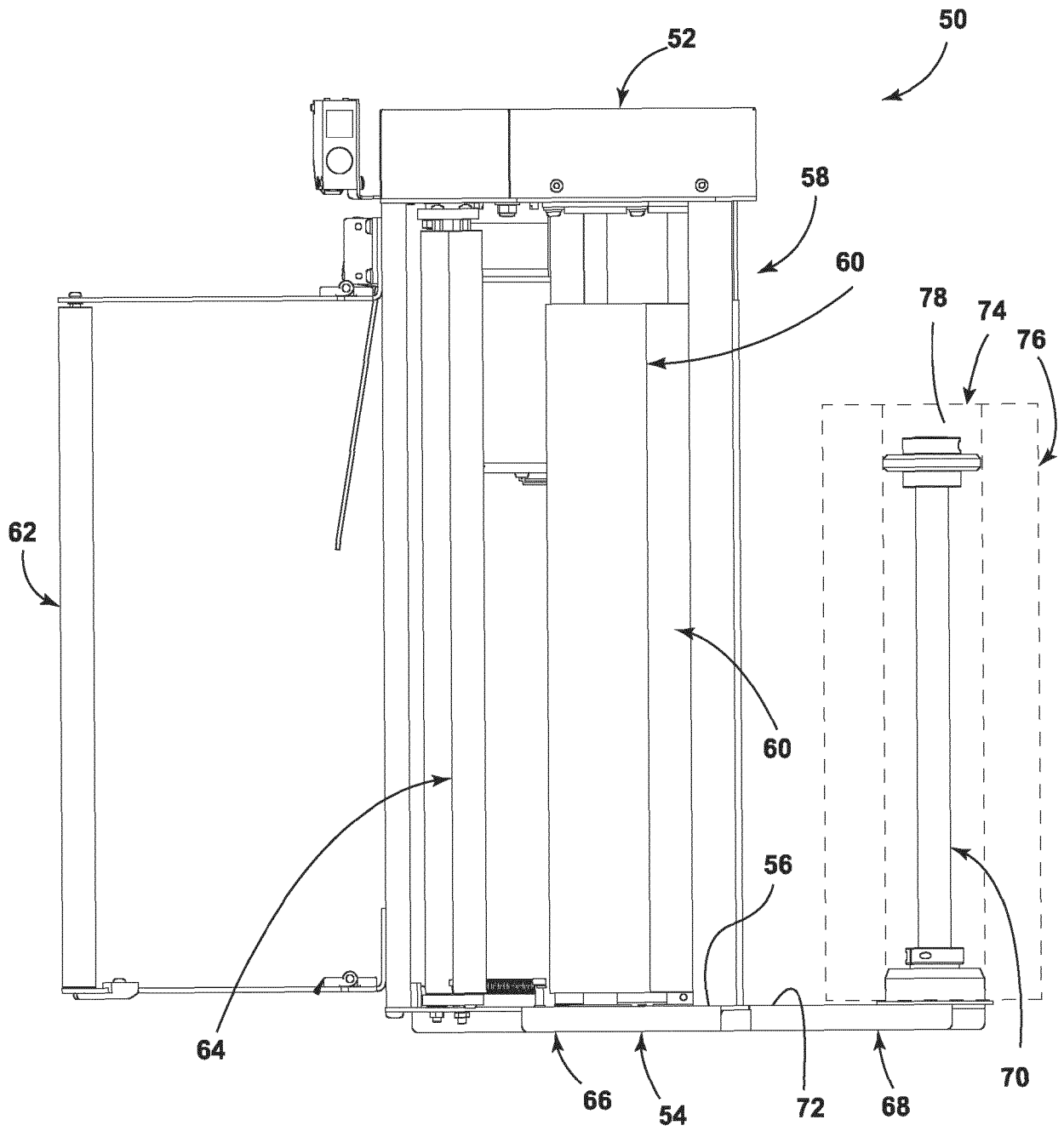
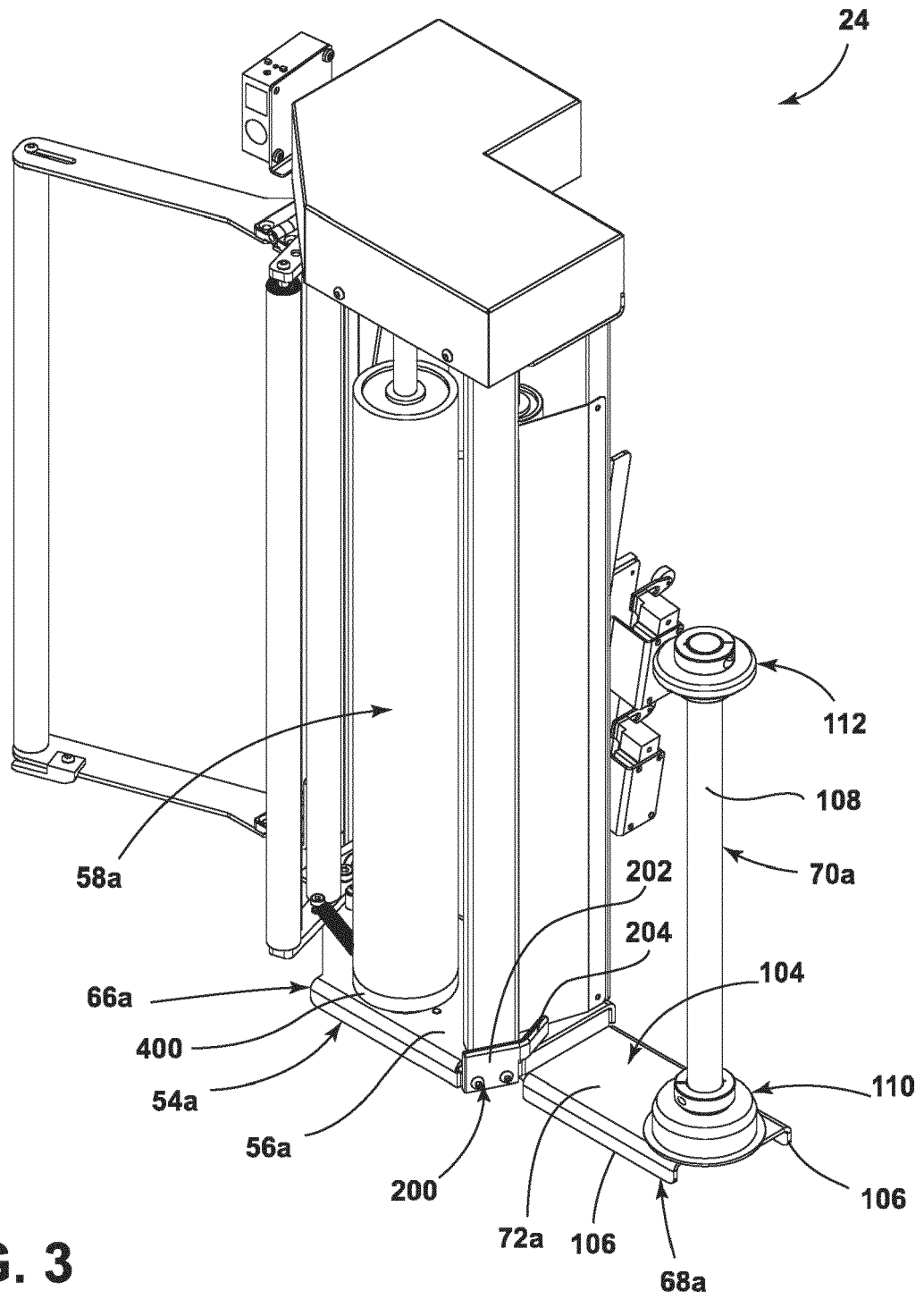

FIG. 1



**FIG. 2 (PRIOR ART)**



**FIG. 3**

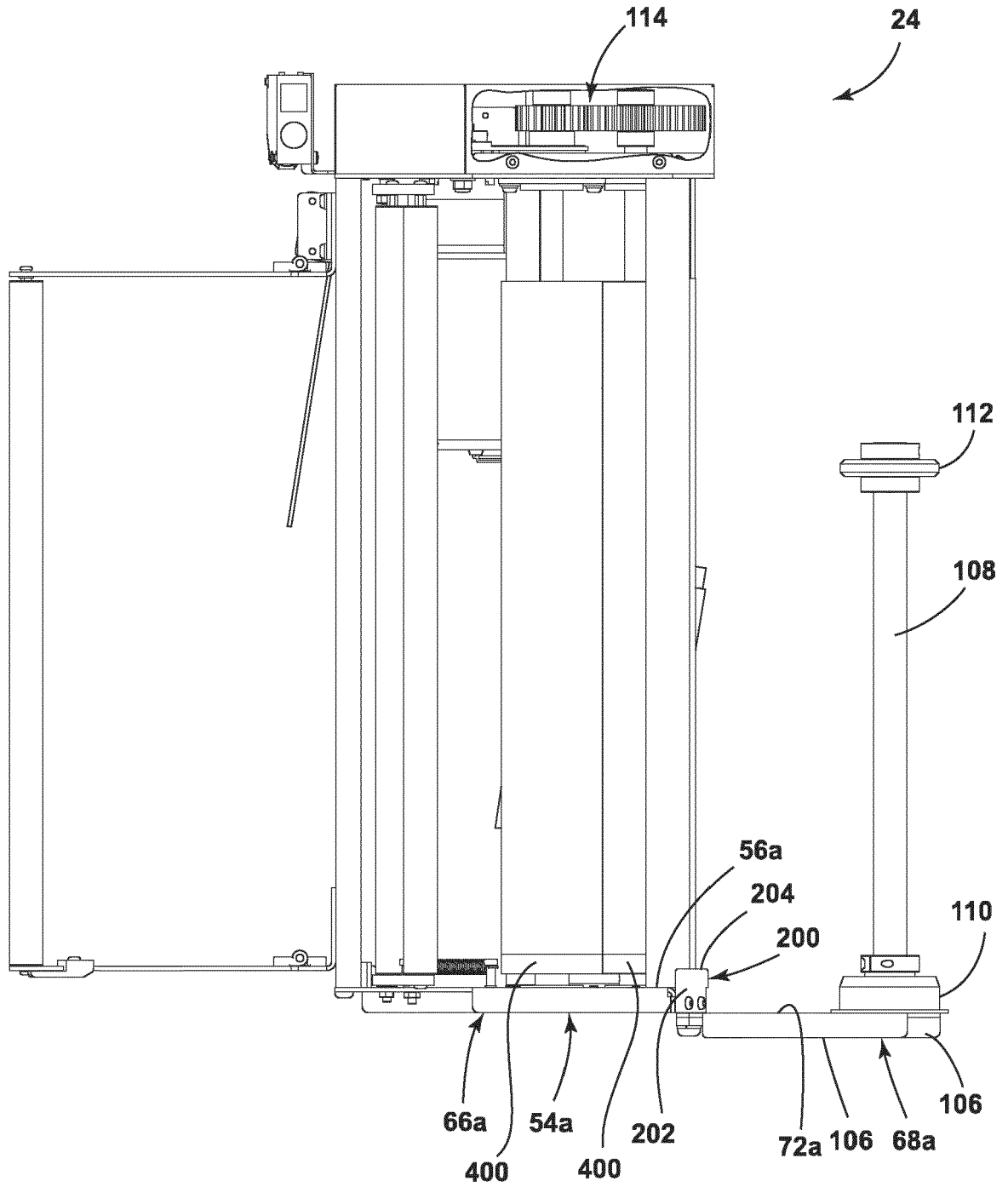
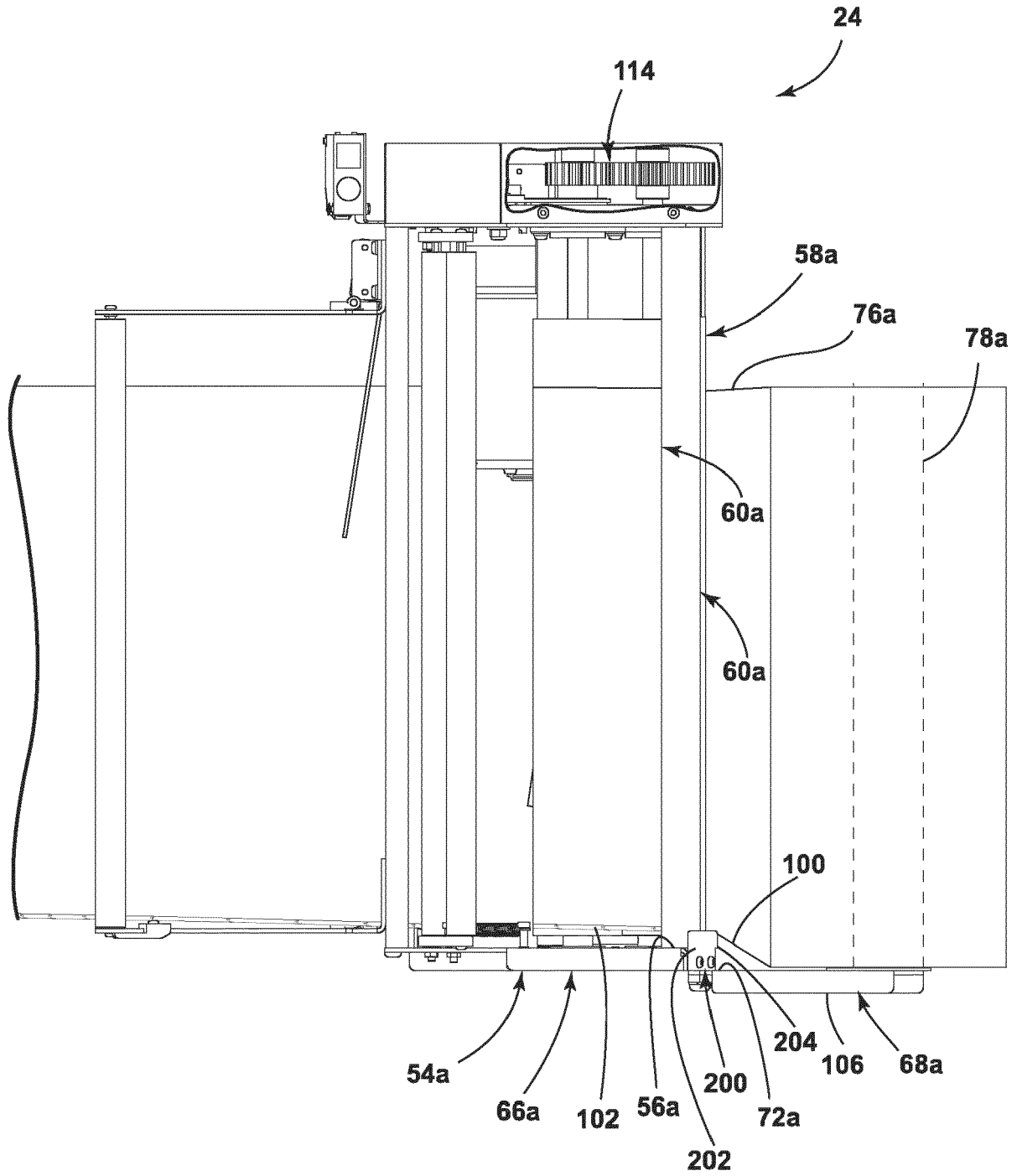
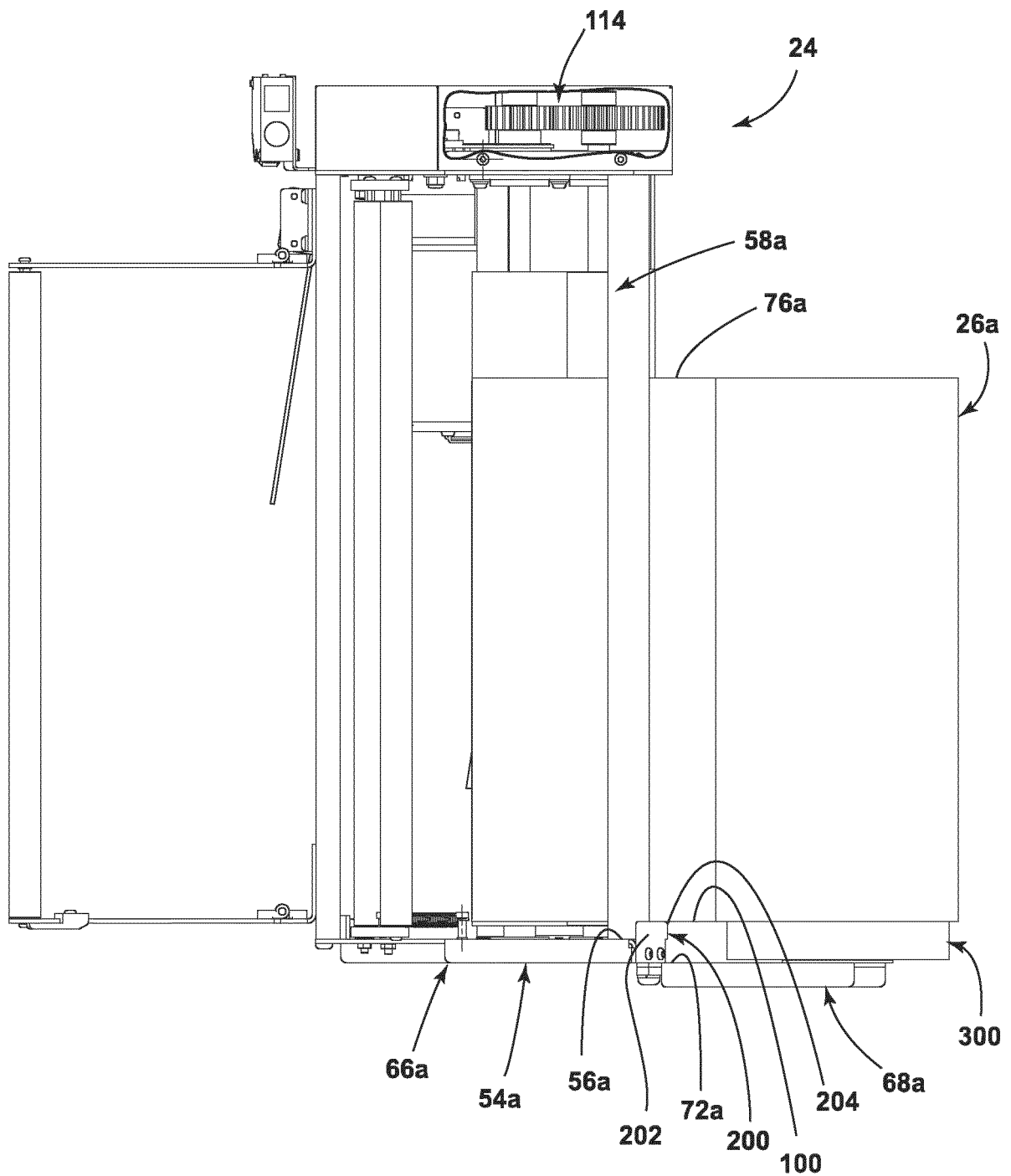

FIG. 4

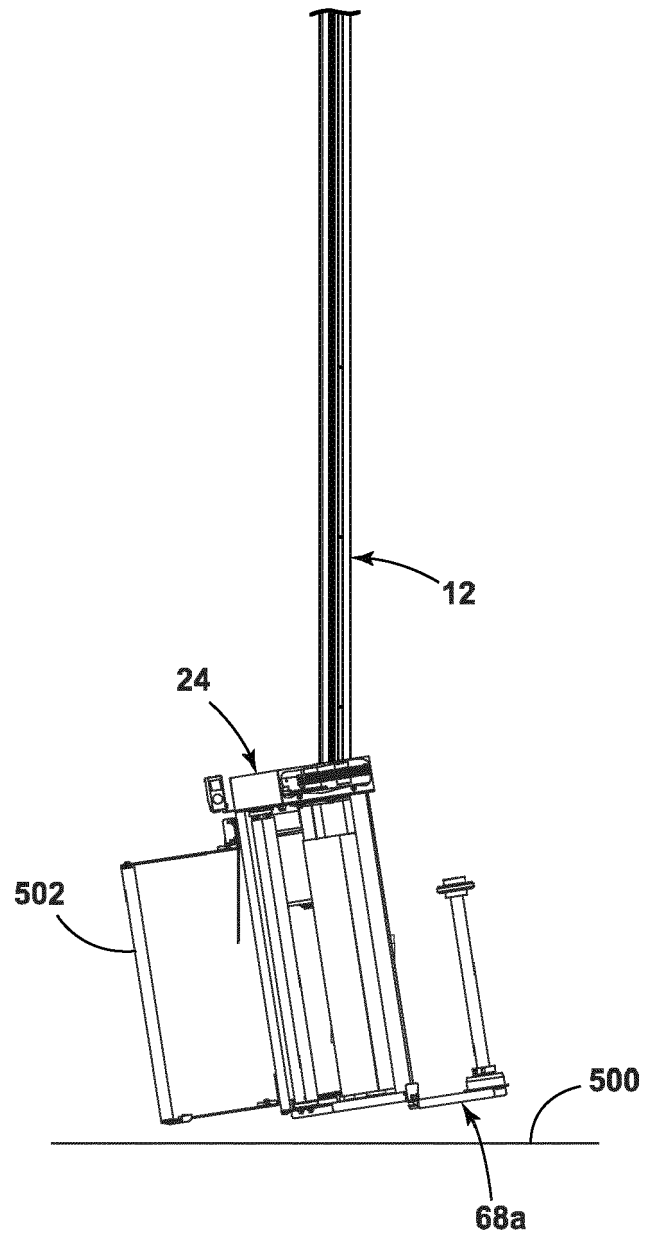



**FIG. 6**



**FIG. 7**



**FIG. 8**



EUROPEAN SEARCH REPORT

Application Number

EP 21 20 3470

5

10

15

20

25

30

35

40

45

50

55

DOCUMENTS CONSIDERED TO BE RELEVANT			
Category	Citation of document with indication, where appropriate, of relevant passages	Relevant to claim	CLASSIFICATION OF THE APPLICATION (IPC)
Y	US 10 183 773 B2 (ZIERDEN DANA L [US]; SAGEDAHL MALLORY K [US]; BRENTON LLC [US]) 22 January 2019 (2019-01-22) * the whole document *	1-11	INV. B65B11/02
Y	US 2009/235617 A1 (MOORE PHILIP R [US] ET AL) 24 September 2009 (2009-09-24) * the whole document *	1-11	
A	US 8 549 819 B1 (BISON DARREL [US]) 8 October 2013 (2013-10-08) * the whole document *	1	
A	US 2006/254225 A1 (LANCASTER PATRICK R III [US] ET AL) 16 November 2006 (2006-11-16) * the whole document *	1	
A	US 2011/067364 A1 (COUSINS NEIL G [CA] ET AL) 24 March 2011 (2011-03-24) * the whole document *	1	
			TECHNICAL FIELDS SEARCHED (IPC)
			B65B
The present search report has been drawn up for all claims			
Place of search <b>Munich</b>		Date of completion of the search <b>25 March 2022</b>	Examiner <b>Ungureanu, Mirela</b>
CATEGORY OF CITED DOCUMENTS X : particularly relevant if taken alone Y : particularly relevant if combined with another document of the same category A : technological background O : non-written disclosure P : intermediate document		T : theory or principle underlying the invention E : earlier patent document, but published on, or after the filing date D : document cited in the application L : document cited for other reasons ..... & : member of the same patent family, corresponding document	

1  
EPO FORM 1503 03:82 (P04C01)

ANNEX TO THE EUROPEAN SEARCH REPORT  
ON EUROPEAN PATENT APPLICATION NO.

EP 21 20 3470

5 This annex lists the patent family members relating to the patent documents cited in the above-mentioned European search report.  
The members are as contained in the European Patent Office EDP file on  
The European Patent Office is in no way liable for these particulars which are merely given for the purpose of information.

25-03-2022

Patent document cited in search report	Publication date	Patent family member(s)	Publication date
US 10183773 B2	22-01-2019	NONE	
US 2009235617 A1	24-09-2009	AU 2009228482 A1 CA 2718998 A1 EP 2276669 A1 JP 2011517438 A US 2009235617 A1 WO 2009120681 A1	01-10-2009 01-10-2009 26-01-2011 09-06-2011 24-09-2009 01-10-2009
US 8549819 B1	08-10-2013	NONE	
US 2006254225 A1	16-11-2006	US 2006254225 A1 WO 2006099097 A1	16-11-2006 21-09-2006
US 2011067364 A1	24-03-2011	NONE	

**REFERENCES CITED IN THE DESCRIPTION**

*This list of references cited by the applicant is for the reader's convenience only. It does not form part of the European patent document. Even though great care has been taken in compiling the references, errors or omissions cannot be excluded and the EPO disclaims all liability in this regard.*

**Patent documents cited in the description**

- US 569170 A [0009]
- US 8166732 B [0009]
- US 7908830 B [0011]