



(19) **United States**  
(12) **Patent Application Publication**  
**Brister et al.**

(10) **Pub. No.: US 2014/0213869 A1**  
(43) **Pub. Date: Jul. 31, 2014**

(54) **ANALYTE SENSOR**

**Publication Classification**

(71) Applicant: **DexCom, Inc.**, San Diego, CA (US)  
(72) Inventors: **Mark Brister**, Encinitas, CA (US); **Sean Saint**, San Diego, CA (US); **Vance Swanson**, San Diego, CA (US); **Nelson Quintana**, San Diego, CA (US)  
(73) Assignee: **DexCom, Inc.**, San Diego, CA (US)

(51) **Int. Cl.**  
*A61B 5/145* (2006.01)  
*A61M 5/172* (2006.01)  
*A61B 5/1473* (2006.01)  
(52) **U.S. Cl.**  
CPC ..... *A61B 5/14532* (2013.01); *A61B 5/1473* (2013.01); *A61M 5/1723* (2013.01)  
USPC ..... **600/347**; 600/365; 604/66

(21) Appl. No.: **14/256,716**  
(22) Filed: **Apr. 18, 2014**

**Related U.S. Application Data**

(63) Continuation of application No. 11/543,490, filed on Oct. 4, 2006.

(57) **ABSTRACT**

Systems and methods of use for continuous analyte measurement of a host's vascular system are provided. In some embodiments, a continuous glucose measurement system includes a vascular access device, a sensor and sensor electronics, the system being configured for insertion into a host's peripheral vein or artery.

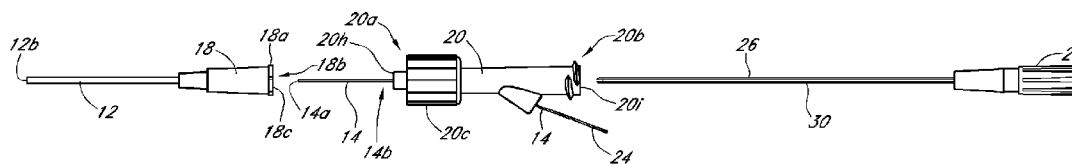
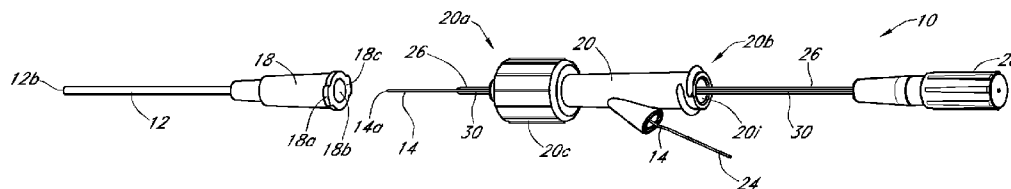

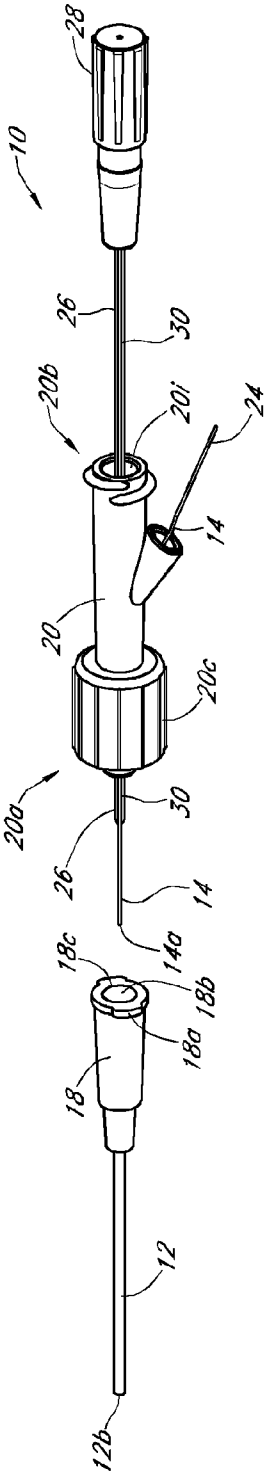

FIG. 1A

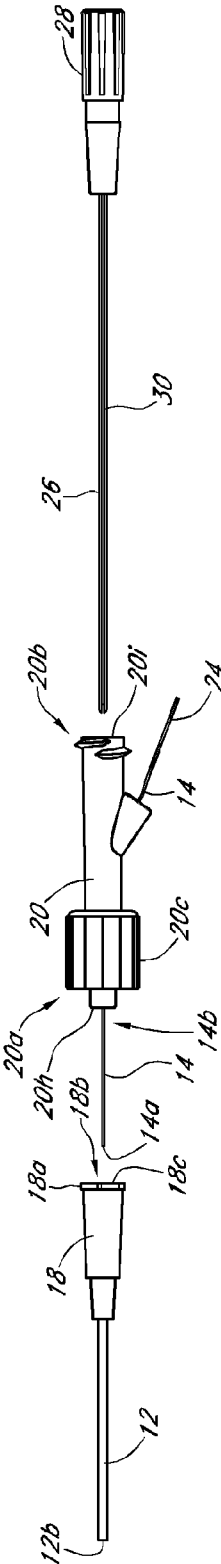

FIG. 1B

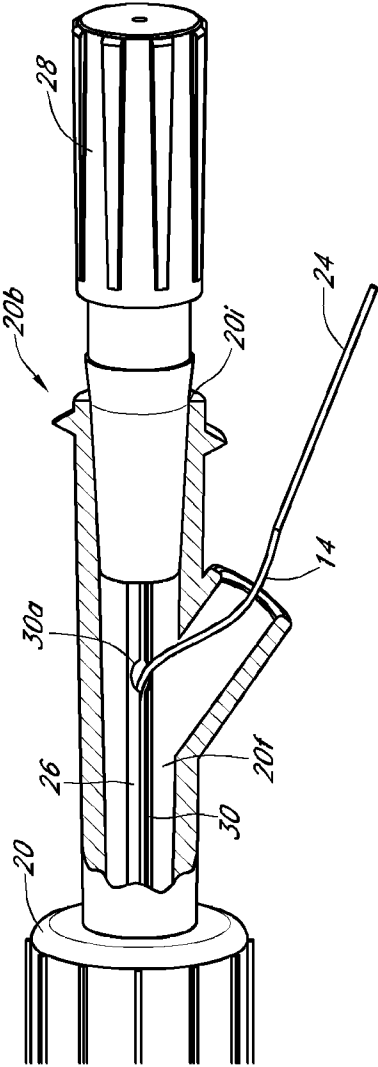

FIG. 1C<sub>1</sub>

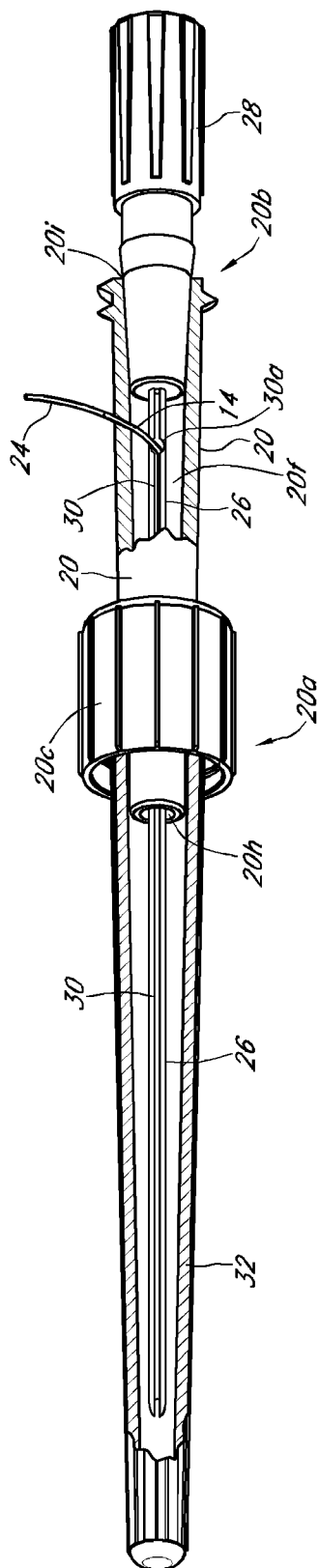

FIG. 1C<sub>2</sub>

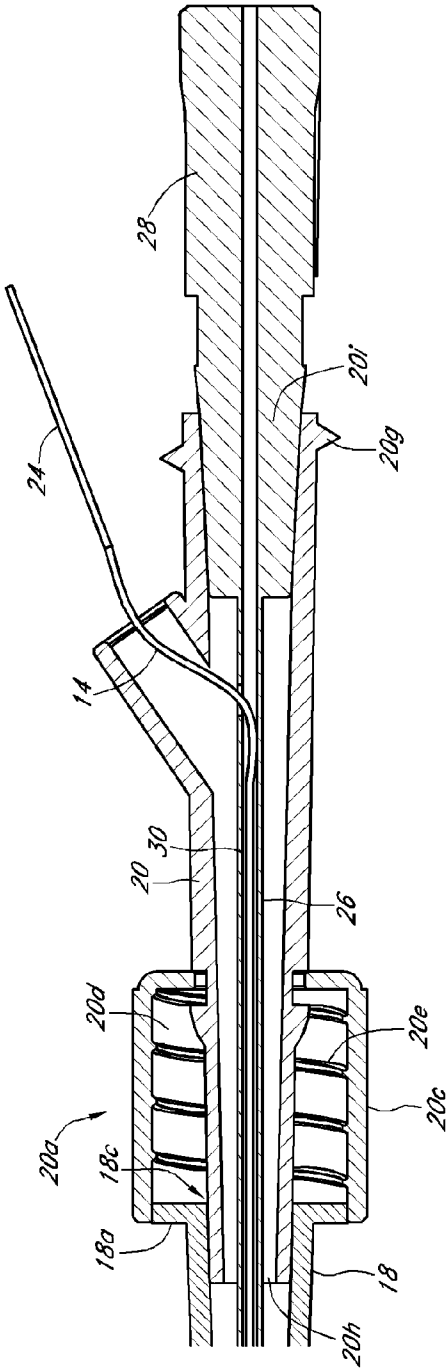

FIG. 1D

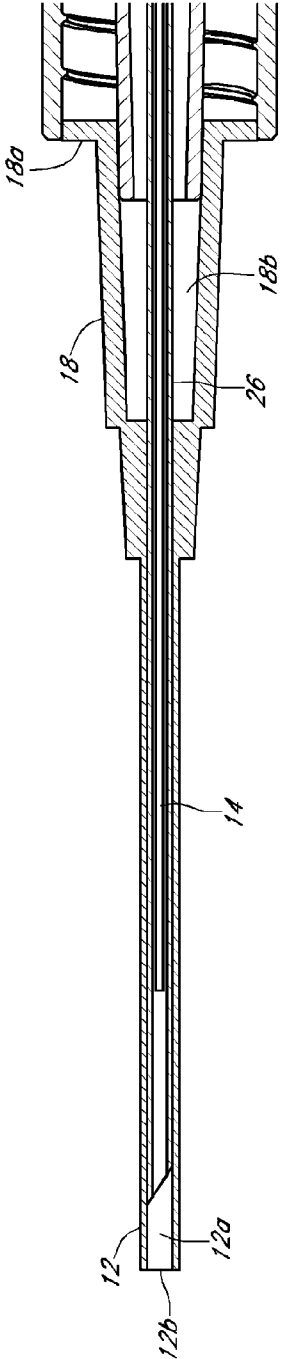

FIG. 1E

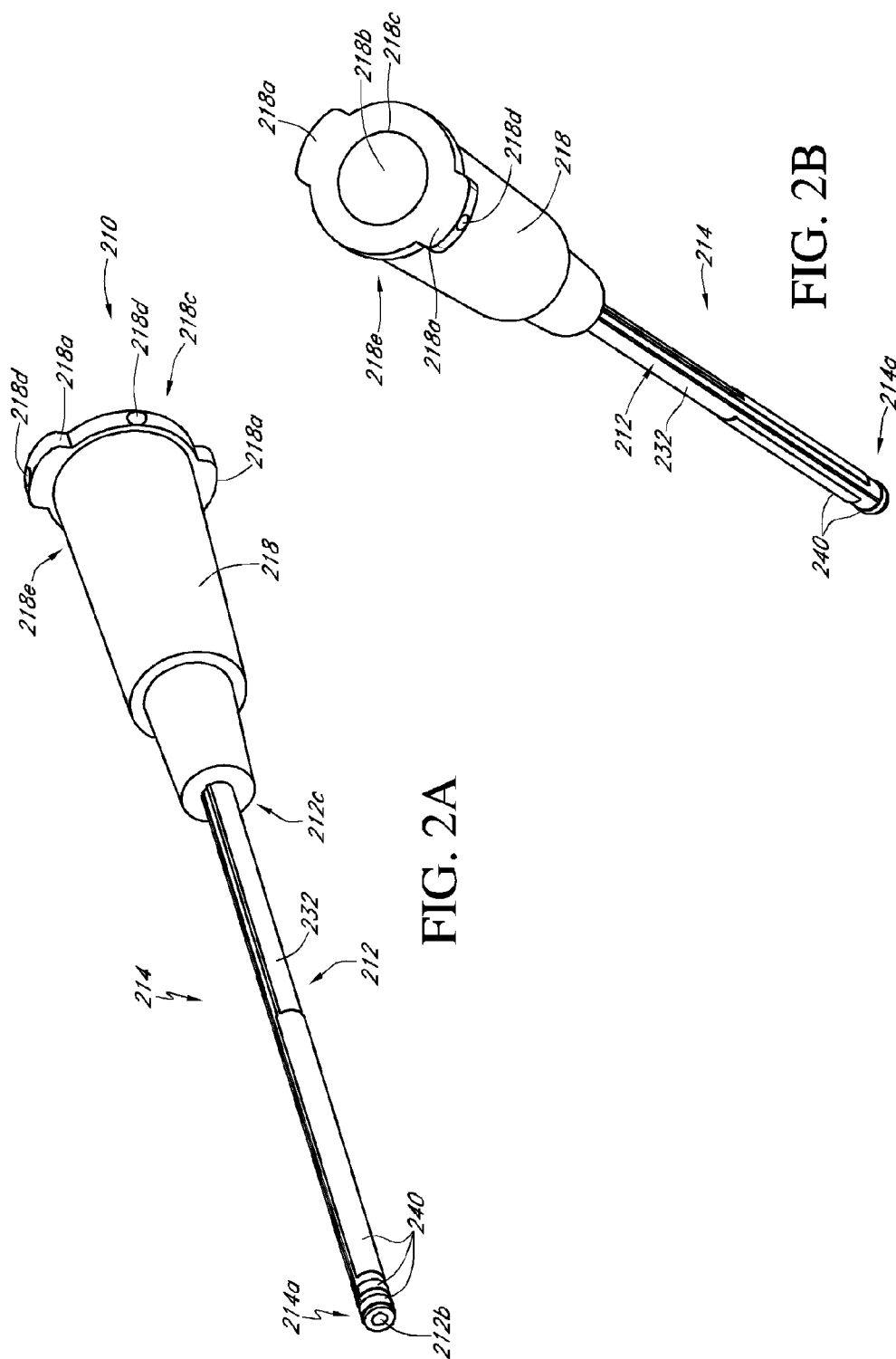

FIG. 2A

FIG. 2B

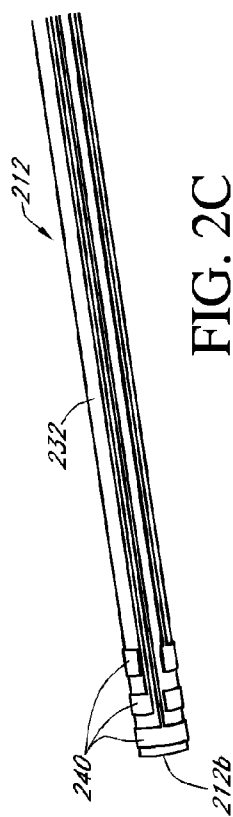

FIG. 2C

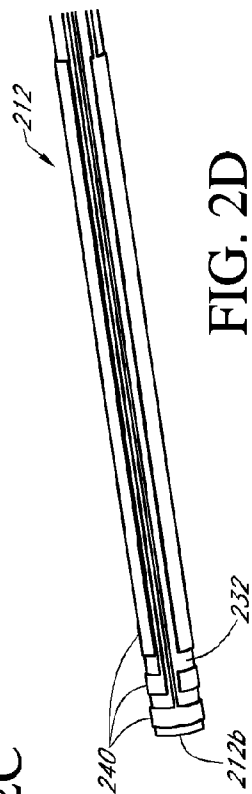

FIG. 2D

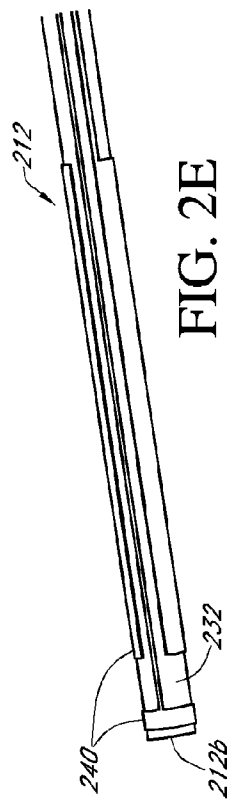

FIG. 2E

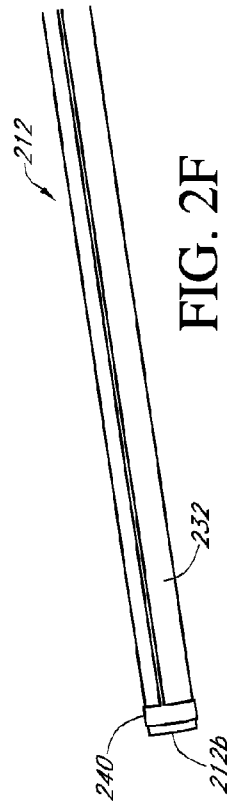

FIG. 2F

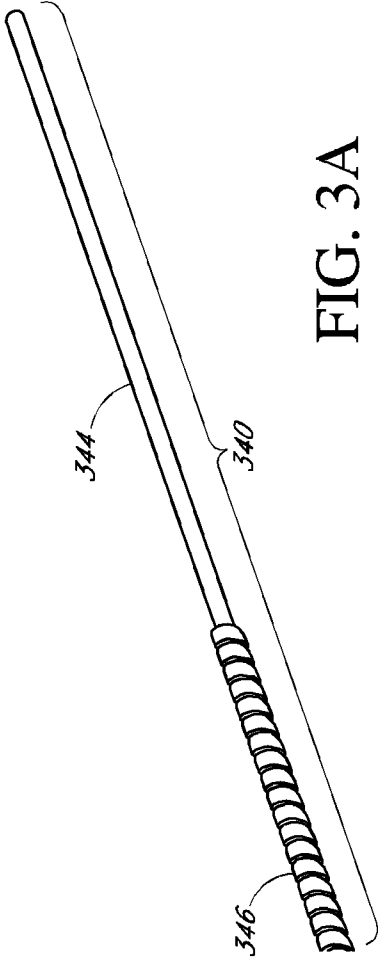

FIG. 3A

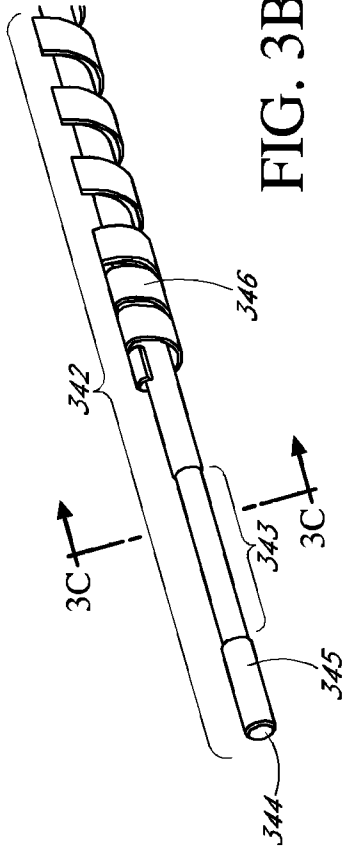

FIG. 3B



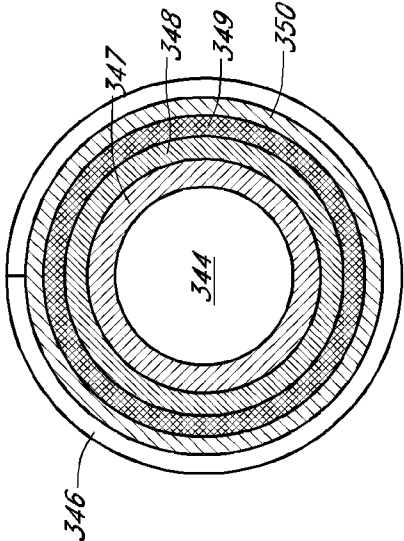

FIG. 3C

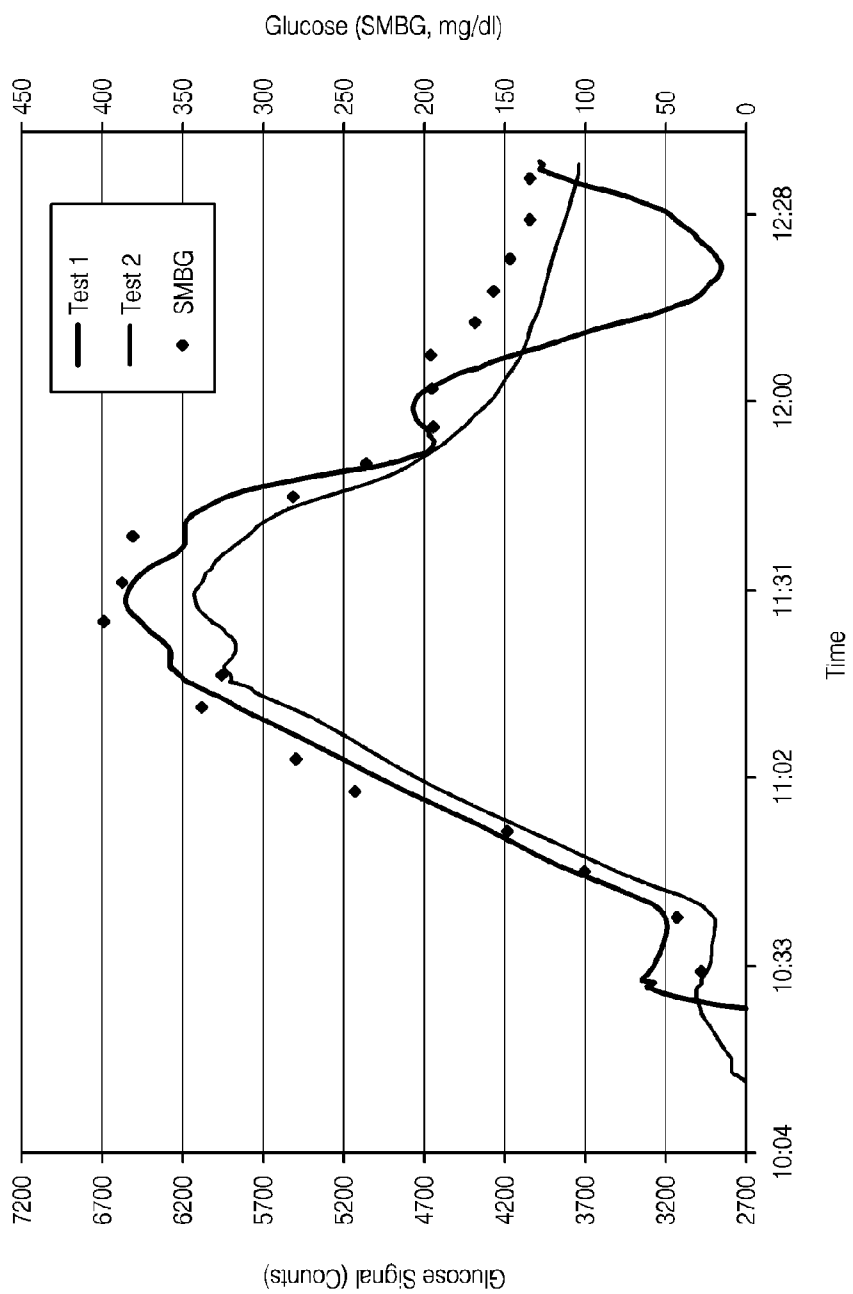

FIG. 4

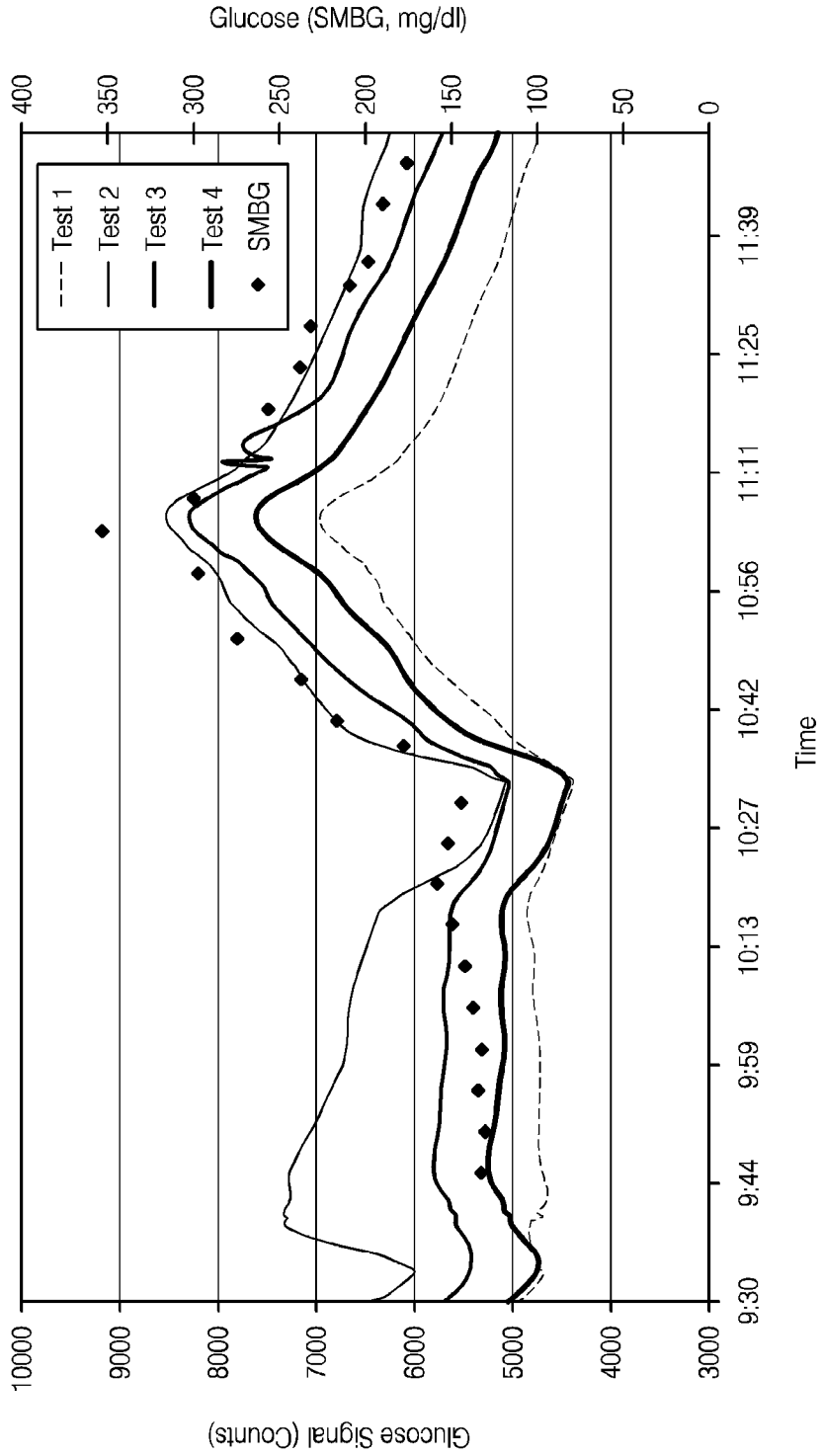

FIG. 5

## ANALYTE SENSOR

### INCORPORATION BY REFERENCE TO RELATED APPLICATIONS

**[0001]** Any and all priority claims identified in the Application Data Sheet, or any correction thereto, are hereby incorporated by reference under 37 CFR 1.57. This application is a continuation of U.S. application Ser. No. 11/543,490, filed on Oct. 4, 2006. The aforementioned application is incorporated by reference herein in its entirety, and is hereby expressly made a part of this specification.

### FIELD OF THE INVENTION

**[0002]** The preferred embodiments relate generally to systems and methods for measuring an analyte in a host.

### BACKGROUND OF THE INVENTION

**[0003]** Diabetes mellitus is a disorder in which the pancreas cannot create sufficient insulin (Type I or insulin dependent) and/or in which insulin is not effective (Type 2 or non-insulin dependent). In the diabetic state, the victim suffers from high blood sugar, which can cause an array of physiological derangements associated with the deterioration of small blood vessels, for example, kidney failure, skin ulcers, or bleeding into the vitreous of the eye. A hypoglycemic reaction (low blood sugar) can be induced by an inadvertent overdose of insulin, or after a normal dose of insulin or glucose-lowering agent accompanied by extraordinary exercise or insufficient food intake.

**[0004]** Conventionally, a person with diabetes carries a self-monitoring blood glucose (SMBG) monitor, which typically requires uncomfortable finger pricking methods. Due to the lack of comfort and convenience, a person with diabetes normally only measures his or her glucose levels two to four times per day. Unfortunately, such time intervals are so far spread apart that the person with diabetes likely finds out too late of a hyperglycemic or hypoglycemic condition, sometimes incurring dangerous side effects. It is not only unlikely that a person with diabetes will take a timely SMBG value, it is also likely that he or she will not know if his or her blood glucose value is going up (higher) or down (lower) based on conventional methods. This inhibits the ability to make educated insulin therapy decisions.

**[0005]** A variety of sensors are known that use an electrochemical cell to provide output signals by which the presence or absence of an analyte, such as glucose, in a sample can be determined. For example, in an electrochemical cell, an analyte (or a species derived from it) that is electro-active generates a detectable signal at an electrode, and this signal can be used to detect or measure the presence and/or amount within a biological sample. In some conventional sensors, an enzyme is provided that reacts with the analyte to be measured, and the byproduct of the reaction is qualified or quantified at the electrode. An enzyme has the advantage that it can be very specific to an analyte and also, when the analyte itself is not sufficiently electro-active, can be used to interact with the analyte to generate another species which is electro-active and to which the sensor can produce a desired output. In one conventional amperometric glucose oxidase-based glucose sensor, immobilized glucose oxidase catalyzes the oxidation of glucose to form hydrogen peroxide, which is then quantified by amperometric measurement (for example, change in electrical current) through a polarized electrode.

## SUMMARY OF THE INVENTION

**[0006]** In a first aspect, a system for measuring an analyte is provided, the system comprising a vascular access device in communication with a vascular system of a host; and an analyte sensor configured to extend within the vascular access device, wherein the analyte sensor is configured to measure a concentration of an analyte within the vascular system.

**[0007]** In an embodiment of the first aspect, the analyte sensor is configured to extend through the vascular access device and into a blood stream of the host.

**[0008]** In an embodiment of the first aspect, the vascular access device is a catheter.

**[0009]** In an embodiment of the first aspect, the vascular access device is configured for insertion into a vein of the host.

**[0010]** In an embodiment of the first aspect, the vascular access device is configured for insertion into an artery of the host.

**[0011]** In an embodiment of the first aspect, the vascular access device is configured to operatively couple to a pressure transducer for measurement of a blood pressure of the host.

**[0012]** In an embodiment of the first aspect, the vascular access device is configured to operatively couple to a blood chemistry analysis device for measuring a blood chemistry of the host.

**[0013]** In an embodiment of the first aspect, the analyte sensor is a glucose sensor.

**[0014]** In an embodiment of the first aspect, the system further comprises a sheath configured to protect the analyte sensor during insertion of the analyte sensor into the catheter. The sheath can comprise a slot configured to allow the release of the analyte sensor therefrom.

**[0015]** In an embodiment of the first aspect, the system further comprises a fluid coupler having first end and second end, wherein the fluid coupler is configured to mate with the vascular access device on the first end, and wherein at least a portion of the analyte sensor extends through the fluid coupler or is housed within the fluid coupler. The fluid coupler can comprise sensor electronics formed thereon. The sensor electronics can a potentiostat. The fluid coupler can be configured to mate with a medical device on the second end. The medical device can comprise at least one device selected from the group consisting of a blood pressure monitor, a blood chemistry device, and a dialysis bypass machine.

**[0016]** In an embodiment of the first aspect, the analyte sensor is configured to extend through the vascular access device and into a blood stream of the host by from about 0.010 inches to about 1 inch.

**[0017]** In an embodiment of the first aspect, the vascular access device and the analyte sensor are configured to indwell within a blood stream of the host in vivo.

**[0018]** In an embodiment of the first aspect, further comprising sensor electronics operatively connected to the analyte sensor.

**[0019]** In an embodiment of the first aspect, the analyte sensor comprises at least one working electrode configured to measure a first signal. The first signal can be substantially analyte related.

**[0020]** In an embodiment of the first aspect, the analyte sensor further comprises a second working electrode configured to measure a second signal. The second signal can be substantially non-analyte related.

[0021] In an embodiment of the first aspect, the sensor electronics are configured to process the second signal and the first signal to determine a concentration of an analyte.

[0022] In an embodiment of the first aspect, the sensor further comprises a reference electrode.

[0023] In an embodiment of the first aspect, the reference electrode is located at a position remote from the working electrode.

[0024] In an embodiment of the first aspect, the sensor further comprises a fluid coupler having first end and a second end, wherein the fluid coupler is configured to mate with the catheter on the first end, wherein at least a portion of the analyte sensor extends through the fluid coupler or is housed within the fluid coupler, and wherein the reference electrode is located at a position proximal to the fluid coupler or within the fluid coupler.

[0025] In an embodiment of the first aspect, an end of the analyte sensor that extends into a blood stream of the host comprises an enlarged area.

[0026] In an embodiment of the first aspect, a substantial portion of the analyte sensor has a diameter of less than about 0.008 inches.

[0027] In an embodiment of the first aspect, a substantial portion of the analyte sensor has a diameter of less than about 0.004 inches.

[0028] In an embodiment of the first aspect, the analyte sensor further comprises a bioinert material or a bioactive agent incorporated therein or thereon. The bioactive agent can comprise at least one agent selected from the group consisting of vitamin K antagonists, heparin group anticoagulants, platelet aggregation inhibitors, enzymes, direct thrombin inhibitors, Dabigatran, Defibrotide, Dermatan sulfate, Fondaparinux, and Rivaroxaban.

[0029] In an embodiment of the first aspect, the analyte sensor comprises a working electrode and a reference electrode, wherein at least one of the working electrode and the reference electrode comprises a wire.

[0030] In an embodiment of the first aspect, the analyte sensor comprises a working electrode and a reference electrode, wherein the working electrode and the reference electrode are both wires, and wherein the wires are coaxial.

[0031] In an embodiment of the first aspect, the analyte sensor comprises a working electrode and a reference electrode, wherein the working electrode and the reference electrode are both wires, and wherein the wires are juxtapositioned.

[0032] In an embodiment of the first aspect, the analyte sensor comprises a working electrode and a reference electrode, wherein the working electrode and the reference electrode are both wires, and wherein the reference electrode is helically wound around the working electrode.

[0033] In an embodiment of the first aspect, the analyte sensor comprises a working electrode, and wherein the working electrode is flexible.

[0034] In an embodiment of the first aspect, the analyte sensor comprises a working electrode, and wherein the working electrode has a variable stiffness.

[0035] In an embodiment of the first aspect, the analyte sensor comprises at least one wire having a helical configuration, wherein a variable stiffness in the helical wire is provided by at least one of a variable pitch of the helical wire and a variable cross-section of the helical wire.

[0036] In a second aspect, a method for measuring an analyte in a blood stream of a host is provided, the method

comprising inserting a vascular access device into communication with a blood stream of a host; and inserting an analyte sensor into the vascular access device, wherein the analyte sensor measures a concentration of an analyte within the blood stream of the host.

[0037] In an embodiment of the second aspect, the analyte sensor extends through the vascular access device and into the blood stream.

[0038] In an embodiment of the second aspect, the vascular access device is a catheter.

[0039] In an embodiment of the second aspect, the vascular access device is inserted into a vein of the host.

[0040] In an embodiment of the second aspect, the vascular access device is inserted into an artery of the host.

[0041] In an embodiment of the second aspect, the method further comprises coupling a pressure transducer to the analyte sensor.

[0042] In an embodiment of the second aspect, the method further comprises coupling a blood chemistry analysis device to the analyte sensor.

[0043] In an embodiment of the second aspect, the analyte sensor measures glucose.

[0044] In an embodiment of the second aspect, the analyte sensor comprises a fluid coupler for housing the analyte sensor or supporting the analyte sensor, and wherein the method further comprises mating the fluid coupler with the vascular access device on a first end of the fluid coupler.

[0045] In an embodiment of the second aspect, the method further comprises mating the fluid coupler with a medical device on a second end of the fluid coupler.

[0046] In an embodiment of the second aspect, the method further comprises measuring at least one other parameter with the medical device, wherein the parameter is selected from the group consisting of blood pressure and blood chemistry.

[0047] In an embodiment of the second aspect, the step of inserting the analyte sensor comprises inserting the analyte sensor beyond an in vivo end of the vascular access device by from about 0.010 inches to about 1 inch.

[0048] In an embodiment of the second aspect, the vascular access device and the analyte sensor are configured to indwell within a blood stream of the host in vivo.

[0049] In an embodiment of the second aspect, sensor electronics are operatively connected to the analyte sensor, and wherein the method further comprises utilizing sensor electronics to measure a concentration of an analyte within the host.

[0050] In an embodiment of the second aspect, the analyte sensor comprises at least one working electrode, and wherein the method further comprises measuring a first signal at the working electrode, and wherein the first signal is substantially analyte-related.

[0051] In an embodiment of the second aspect, the analyte sensor further comprises a second working electrode, and wherein the method further comprises measuring a second signal at the second working electrode. The second signal can be substantially non-analyte-related.

[0052] In an embodiment of the second aspect, the method further comprises processing the second signal and the first signal to determine a concentration of an analyte.

[0053] In an embodiment of the second aspect, the method further comprises avoiding piercing of a blood vessel during sensor insertion into the blood vessel by providing an enlarged area at an insertion end of the analyte sensor.

**[0054]** In an embodiment of the second aspect, the method further comprises substantially preventing clotting or thrombosis proximal to or on the analyte sensor within the blood stream.

**[0055]** In a third aspect, a system for measuring an analyte is provided, the system comprising a vascular access device configured for insertion communication with a vascular system of a host, wherein the vascular access device comprises an analyte sensor at least partially integrally incorporated therewith; and sensor electronics operatively connected to the analyte sensor, wherein the sensor electronics are configured to measure a concentration of an analyte within the vascular system.

**[0056]** In an embodiment of the third aspect, the sensor electronics are configured to substantially continuously measure the analyte concentration.

**[0057]** In an embodiment of the third aspect, the analyte is glucose.

**[0058]** In an embodiment of the third aspect, the vascular access device is configured to operatively couple to a blood chemistry analysis device for measuring a blood chemistry of the host.

**[0059]** In an embodiment of the third aspect, the analyte sensor comprises at least one working electrode configured measure a first signal.

**[0060]** In an embodiment of the third aspect, the first signal is substantially analyte related.

**[0061]** In an embodiment of the third aspect, the analyte sensor further comprises a second working electrode configured measure a second signal.

**[0062]** In an embodiment of the third aspect, the second signal is substantially non-analyte related.

**[0063]** In an embodiment of the third aspect, the sensor electronics are configured to process the second signal and the first signal to determine a concentration of an analyte.

**[0064]** In an embodiment of the third aspect, the analyte sensor further comprises a reference electrode.

**[0065]** In an embodiment of the third aspect, the reference electrode is located at a position remote from the reference electrode.

**[0066]** In an embodiment of the third aspect, the reference electrode is configured to be located outside of a blood stream of the host.

**[0067]** In an embodiment of the third aspect, the analyte sensor further comprises a counter electrode.

**[0068]** In an embodiment of the third aspect, the analyte sensor is configured to at least partially contact an in vivo blood stream of the host when the vascular access device is inserted therein.

**[0069]** In an embodiment of the third aspect, the analyte sensor is deposited on an exterior surface of the vascular access device.

**[0070]** In an embodiment of the third aspect, the analyte sensor is electroplated onto the exterior surface of the vascular access device.

**[0071]** In an embodiment of the third aspect, the analyte sensor is wired to at least a portion of the sensor electronics.

**[0072]** In an embodiment of the third aspect, the analyte sensor is wirelessly connected to at least a portion of the sensor electronics.

**[0073]** In an embodiment of the third aspect, the vascular access device is a catheter.

**[0074]** In an embodiment of the third aspect, the analyte sensor further comprises a bioinert material or a bioactive

agent incorporated therewith. The bioactive agent can comprise at least one agent selected from the group consisting of vitamin K antagonists, heparin group anticoagulants, platelet aggregation inhibitors, enzymes, direct thrombin inhibitors, Dabigatran, Defibrotide, Dermatan sulfate, Fondaparinux, and Rivaroxaban.

**[0075]** In an embodiment of the third aspect, the analyte sensor comprises a working electrode and a reference electrode, and wherein at least one of the working electrode and the reference electrode comprises a wire.

**[0076]** In an embodiment of the third aspect, the analyte sensor comprises a working electrode and a reference electrode, wherein the working electrode and the reference electrode are both wires, and wherein the wires are coaxial.

**[0077]** In an embodiment of the third aspect, the analyte sensor comprises a working electrode and a reference electrode, wherein the working electrode and the reference electrode are both wires, and wherein the wires are juxtapositioned.

**[0078]** In an embodiment of the third aspect, the analyte sensor comprises a working electrode and a reference electrode, wherein the working electrode and the reference electrode are both wires, and wherein the reference electrode is helically wound around the working electrode.

**[0079]** In an embodiment of the third aspect, the analyte sensor comprises a working electrode, and wherein the working electrode is flexible.

**[0080]** In an embodiment of the third aspect, the analyte sensor comprises a working electrode, and wherein the working electrode has a variable stiffness.

**[0081]** In an embodiment of the third aspect, the analyte sensor comprises at least one wire having a helical configuration, and wherein a variable stiffness in the helical wire is provided by at least one of a variable pitch of the helical wire and a variable cross-section of the helical wire.

**[0082]** In a fourth aspect, a method for measuring an analyte in a blood stream of a host is provided, the method comprising inserting a vascular access device into communication with a blood stream of a host, wherein the vascular access device comprises an analyte sensor at least partially integrally incorporated therewith; operatively connecting the analyte sensor to sensor electronics; and measuring an analyte concentration in the host.

**[0083]** In an embodiment of the fourth aspect, the method further comprises substantially continuously measuring an analyte concentration.

**[0084]** In an embodiment of the fourth aspect, the step of measuring an analyte concentration comprises measuring a glucose concentration.

**[0085]** In an embodiment of the fourth aspect, the analyte sensor comprises at least one working electrode, wherein the measuring step comprises measuring a first signal at the working electrode, wherein the first signal is substantially analyte-related.

**[0086]** In an embodiment of the fourth aspect, the analyte sensor further comprises a second working electrode, and the measuring step further comprises measuring a second signal at the second working electrode, wherein the second signal is substantially non-analyte related.

**[0087]** In an embodiment of the fourth aspect, the method further comprises processing the second signal and the first signal to determine a concentration of an analyte.

**[0088]** In an embodiment of the fourth aspect, the measuring step comprises measuring an analyte concentration in an in vivo blood stream of the host.

**[0089]** In an embodiment of the fourth aspect, the operatively connecting step comprises connecting the analyte sensor to at least a portion of the sensor electronics via a wired connection.

**[0090]** In an embodiment of the fourth aspect, the operatively connecting step comprises connecting the analyte sensor to at least a portion of the sensor electronics via a wireless connection.

**[0091]** In a fifth aspect, a method for manufacturing an analyte sensor configured for measuring an analyte in a vascular system of a host is provided, the method comprising providing a vascular access device; and at least partially integrally incorporating an analyte sensor in the vascular access device or on a surface of the vascular access device.

**[0092]** In an embodiment of the fifth aspect, the step of at least partially integrally incorporating an analyte sensor comprises depositing at least one working electrode on an interior surface of the vascular access device or on an exterior surface of the vascular access device.

**[0093]** In an embodiment of the fifth aspect, the depositing step further comprises electroplating the working electrode onto the exterior surface of the vascular access device.

**[0094]** In an embodiment of the fifth aspect, the step of at least partially integrally incorporating an analyte sensor further comprises depositing a second working electrode on an interior surface of the vascular access device or on an exterior surface of the vascular access device.

**[0095]** In an embodiment of the fifth aspect, the step of at least partially integrally incorporating an analyte sensor further comprises depositing a reference electrode on an interior surface of the vascular access device or on an exterior surface of the vascular access device.

**[0096]** In an embodiment of the fifth aspect, the step of at least partially integrally incorporating an analyte sensor further comprises depositing a counter electrode on an interior surface of the vascular access device or on an exterior surface of the vascular access device.

**[0097]** In an embodiment of the fifth aspect, the surface of the vascular access device is selected from the group consisting of an exterior surface, an interior surface, and a tip surface.

**[0098]** In an embodiment of the fifth aspect, the step of at least partially integrally incorporating an analyte sensor further comprises forming a reference electrode at a location remote from the working electrode.

**[0099]** In a sixth aspect, a method for calibrating a continuous analyte sensor in a host is provided, the method comprising inserting a continuous analyte sensor into a host; contacting a calibration solution with at least a portion of the continuous analyte sensor; and calibrating the continuous analyte sensor to provide calibrated analyte sensor data comprising at least one calibrated sensor data point.

**[0100]** In an embodiment of the sixth aspect, the continuous analyte sensor is configured to indwell within a blood stream of a host.

**[0101]** In an embodiment of the sixth aspect, the continuous analyte sensor is configured to measure a glucose concentration in the host.

**[0102]** In an embodiment of the sixth aspect, the calibration solution comprises a predetermined amount of glucose.

**[0103]** In an embodiment of the sixth aspect, the method further comprises displaying the calibrated analyte sensor data.

**[0104]** In an embodiment of the sixth aspect, the method further comprises contacting an additional calibration solution with at least a portion of the continuous analyte sensor.

**[0105]** In an embodiment of the sixth aspect, the method further comprises calibrating or re-calibrating the continuous analyte sensor to provide calibrated analyte sensor data comprising at least one calibrated sensor data point.

**[0106]** In an embodiment of the sixth aspect, the step of contacting an additional calibration solution is repeated.

**[0107]** In an embodiment of the sixth aspect, the step of contacting an additional calibration solution is performed automatically.

**[0108]** In an embodiment of the sixth aspect, the step of contacting an additional calibration solution is performed manually.

**[0109]** In an embodiment of the sixth aspect, the method further comprises contacting a non-analyte solution with at least a portion of the continuous analyte sensor to flush the sensor.

**[0110]** In an embodiment of the sixth aspect, the step of contacting a non-analyte solution is performed prior to the step of contacting a calibration solution with at least a portion of the continuous analyte sensor.

**[0111]** In a seventh aspect, a method for calibrating a continuous analyte sensor in a host is provided, the method comprising inserting a continuous analyte sensor system into a host; withdrawing at least one blood sample from the host; measuring a reference analyte value from the blood sample; and calibrating the continuous analyte sensor to provide calibrated analyte sensor data comprising at least one calibrated sensor data point.

**[0112]** In an embodiment of the seventh aspect, the continuous analyte sensor is configured to indwell within a blood stream of the host.

**[0113]** In an embodiment of the seventh aspect, the continuous analyte sensor is configured to measure a glucose concentration of the host.

**[0114]** In an embodiment of the seventh aspect, the step of withdrawing at least one blood sample from the host is performed automatically.

**[0115]** In an embodiment of the seventh aspect, the step of inserting a continuous analyte sensor comprises inserting a vascular access device into communication with a vascular system of the host, wherein the sensor is integrally incorporated with the vascular access device.

**[0116]** In an embodiment of the seventh aspect, the step of withdrawing comprises withdrawing a blood sample through the vascular access device.

**[0117]** In an embodiment of the seventh aspect, the method further comprises inserting a vascular access device into communication with a vascular system of the host, wherein the sensor is inserted through the vascular access device.

**[0118]** In an embodiment of the seventh aspect, the step of withdrawing comprises withdrawing a blood sample through the vascular access device.

**[0119]** In an embodiment of the seventh aspect, the method further comprises displaying the calibrated sensor data.

**[0120]** In an embodiment of the seventh aspect, the method further comprises coupling a blood chemistry device to the continuous analyte sensor system.

**[0121]** In an embodiment of the seventh aspect, the blood chemistry device performs the step of analyzing at least one blood sample from the host.

**[0122]** In an embodiment of the seventh aspect, the blood chemistry device performs the step of measuring a reference analyte value from the blood sample.

**[0123]** In an eighth aspect, a continuous analyte sensor system is provided, the system comprising a continuous analyte sensor configured for insertion into a host; and a computer system operatively connected to the continuous analyte sensor, wherein the computer system is configured to receive analyte sensor data from the continuous analyte sensor, the analyte sensor data comprising at least one sensor data point and calibration information, and wherein the computer system is configured to calibrate the analyte sensor data from the calibration information.

**[0124]** In an embodiment of the eighth aspect, the analyte sensor is a glucose sensor.

**[0125]** In an embodiment of the eighth aspect, the continuous analyte sensor comprises a vascular access device configured for communication with a vascular system of the host, and wherein the continuous analyte sensor is configured to extend through the vascular access device, wherein the analyte sensor is configured to measure a concentration of an analyte within a vascular system of the host.

**[0126]** In an embodiment of the eighth aspect, the vascular access device is configured to operatively couple to a blood chemistry analysis device for measuring a blood chemistry of the host.

**[0127]** In an embodiment of the eighth aspect, the blood chemistry device is configured to withdraw a blood sample through the vascular access device, and wherein the calibration information comprises the blood sample or a measurement associated therewith.

**[0128]** In an embodiment of the eighth aspect, the blood chemistry device is configured to measure a reference analyte value from the host, and wherein the calibration information comprises the reference analyte value.

**[0129]** In an embodiment of the eighth aspect, the system further comprises a device configured to automatically obtain the calibration information, wherein the device is operatively coupled to the sensor system.

**[0130]** In an embodiment of the eighth aspect, the continuous analyte sensor comprises a vascular access device configured for communication with a vascular system of the host, wherein the vascular access device comprises an analyte sensor at least partially integrally incorporated on an exterior surface the vascular access device and further comprises sensor electronics operatively connected to the analyte sensor, wherein the sensor electronics are configured to measure a concentration of an analyte within a blood stream of the host.

**[0131]** In an embodiment of the eighth aspect, the vascular access device is configured to operatively couple to a blood chemistry analysis device for measuring a blood chemistry of the host.

**[0132]** In an embodiment of the eighth aspect, the blood chemistry device is configured to withdraw a blood sample through the vascular access device, and wherein the calibration information comprises the blood sample or a measurement associated therewith.

**[0133]** In an embodiment of the eighth aspect, the blood chemistry device is configured to measure a reference analyte value from the host, and wherein the calibration information comprises the reference analyte value.

**[0134]** In an embodiment of the eighth aspect, the system further comprises a device configured to automatically obtain the calibration information, wherein the device is operatively coupled to the sensor system.

**[0135]** In an embodiment of the eighth aspect, the analyte sensor comprises a working electrode and a reference electrode, and wherein at least one of the working electrode and the reference electrode comprises a wire.

**[0136]** In an embodiment of the eighth aspect, the analyte sensor comprises a working electrode and a reference electrode, wherein the working electrode and the reference electrode are both wires, and wherein the wires are coaxial.

**[0137]** In an embodiment of the eighth aspect, the analyte sensor comprises a working electrode and a reference electrode, wherein the working electrode and the reference electrode are both wires, and wherein the wires are juxtapositioned.

**[0138]** In an embodiment of the eighth aspect, the analyte sensor comprises a working electrode and a reference electrode, wherein the working electrode and the reference electrode are both wires, and wherein the reference electrode is helically wound around the working electrode.

**[0139]** In an embodiment of the eighth aspect, the analyte sensor comprises a working electrode, and wherein the working electrode is flexible.

**[0140]** In an embodiment of the eighth aspect, the analyte sensor comprises a working electrode, and wherein the working electrode has a variable stiffness.

**[0141]** In an embodiment of the eighth aspect, the analyte sensor comprises at least one wire having a helical configuration, and wherein a variable stiffness in the helical wire is provided by at least one of a variable pitch of the helical wire and a variable cross-section of the helical wire.

#### BRIEF DESCRIPTION OF THE DRAWINGS

**[0142]** FIG. 1A is a perspective view of one embodiment of an analyte sensor system, including a vascular access device (e.g., a catheter), a sensor, a fluid connector, and a protective sheath.

**[0143]** FIG. 1B is a side view of the analyte sensor system of FIG. 1A, showing the protective sheath removed.

**[0144]** FIG. 1C1 is a close-up cut away view of a portion of the analyte sensor system of FIG. 1A.

**[0145]** FIG. 1C2 is a close-up cut away view of a portion of the analyte sensor system of FIG. 1A.

**[0146]** FIG. 1D is a close-up cut away view of a portion of the analyte sensor system of FIG. 1A.

**[0147]** FIG. 1E is a close-up cut away view of a portion of the analyte sensor system of FIG. 1A.

**[0148]** FIG. 2A is a perspective view of another embodiment of the analyte sensor system, including a catheter with a sensor integrally formed thereon.

**[0149]** FIG. 2B is a perspective view of the analyte sensor system of FIG. 2A.

**[0150]** FIG. 2C is a close-up view of a portion of the analyte sensor system of FIG. 2A in an alternative configuration of an embodiment having three electrodes disposed on the catheter.

**[0151]** FIG. 2D is a close-up view of a portion of the analyte sensor system of FIG. 2A in an alternative configuration of an embodiment having three electrodes disposed on the catheter.

**[0152]** FIG. 2E is a close-up view of a portion of the analyte sensor system of FIG. 2A in an alternative embodiment having two electrodes disposed on the catheter.



[0153] FIG. 2F is a close-up view of a portion of the analyte sensor system of FIG. 2A in an alternative embodiment having one electrode disposed on the catheter.

[0154] FIG. 3A is a perspective view of a first portion of one embodiment of an analyte sensor.

[0155] FIG. 3B is a perspective view of a second portion of the analyte sensor of FIG. 3A.

[0156] FIG. 3C is a cross section of the analyte sensor of FIG. 3B, taken on line C-C.

[0157] FIG. 4 is a graph illustrating in vivo function of an analyte sensor system of the embodiment shown in FIG. 1A.

[0158] FIG. 5 is a graph illustrating in vivo function of an analyte sensor system of the embodiment shown in FIG. 1A.

#### DETAILED DESCRIPTION OF THE PREFERRED EMBODIMENT

[0159] The following description and examples illustrate some exemplary embodiments of the disclosed invention in detail. Those of skill in the art will recognize that there are numerous variations and modifications of this invention that are encompassed by its scope. Accordingly, the description of a certain exemplary embodiment should not be deemed to limit the scope of the preferred embodiments.

#### DEFINITIONS

[0160] In order to facilitate an understanding of the preferred embodiments, a number of terms are defined below.

[0161] The term “analyte” as used herein is a broad term, and is to be given its ordinary and customary meaning to a person of ordinary skill in the art (and is not to be limited to a special or customized meaning), and refers without limitation to a substance or chemical constituent in a biological fluid (for example, blood, interstitial fluid, cerebral spinal fluid, lymph fluid or urine) that can be analyzed. Analytes can include naturally occurring substances, artificial substances, metabolites, and/or reaction products. In some embodiments, the analyte for measurement by the sensing regions, devices, and methods is glucose. However, other analytes are contemplated as well, including but not limited to acarboxyprothrombin; acylcarnitine; adenine phosphoribosyl transferase; adenosine deaminase; albumin; alpha-fetoprotein; amino acid profiles (arginine (Krebs cycle), histidine/urocanic acid, homocysteine, phenylalanine/tyrosine, tryptophan); androstenedione; antipyrine; arabinitol enantiomers; arginase; benzoylcegonine (cocaine); biotinidase; bipterin; c-reactive protein; carnitine; carnosinase; CD4; ceruloplasmin; chenodeoxycholic acid; chloroquine; cholesterol; cholinesterase; conjugated 1-β hydroxy-cholic acid; cortisol; creatine kinase; creatine kinase MM isoenzyme; cyclosporin A; d-penicillamine; de-ethylchloroquine; dehydroepiandrosterone sulfate; DNA (acetylator polymorphism, alcohol dehydrogenase, alpha 1-antitrypsin, cystic fibrosis, Duchenne/Becker muscular dystrophy, glucose-6-phosphate dehydrogenase, hemoglobin A, hemoglobin S, hemoglobin C, hemoglobin D, hemoglobin E, hemoglobin F, D-Punjab, beta-thalassemia, hepatitis B virus, HCMV, HIV-1, HTLV-1, Leber hereditary optic neuropathy, MCAD, RNA, PKU, *Plasmodium vivax*, sexual differentiation, 21-deoxycortisol); desbutylhalofantrine; dihydropteridine reductase; diptheria/tetanus antitoxin; erythrocyte arginase; erythrocyte protoporphyrin; esterase D; fatty acids/acylglycines; free β-human chorionic gonadotropin; free erythrocyte porphyrin; free thyroxine (FT4); free tri-iodothyronine (FT3); fumarylacetoac-

etase; galactose/gal-1-phosphate; galactose-1-phosphate uridylyltransferase; gentamicin; glucose-6-phosphate dehydrogenase; glutathione; glutathione peroxidase; glycocholic acid; glycosylated hemoglobin; halofantrine; hemoglobin variants; hexosaminidase A; human erythrocyte carbonic anhydrase I; 17-alpha-hydroxyprogesterone; hypoxanthine phosphoribosyl transferase; immunoreactive trypsin; lactate; lead; lipoproteins ((a), B/A-1, β); lysozyme; mefloquine; netilmicin; phenobarbitone; phenyloin; phytanic/pristanic acid; progesterone; prolactin; prolidase; purine nucleoside phosphorylase; quinine; reverse tri-iodothyronine (rT3); selenium; serum pancreatic lipase; sissomicin; somatomedin C; specific antibodies (adenovirus, anti-nuclear antibody, anti-zeta antibody, arbovirus, Aujesky's disease virus, dengue virus, *Dracunculus medinensis*, *Echinococcus granulosus*, *Entamoeba histolytica*, enterovirus, *Giardia duodenalis*, *Helicobacter pylori*, hepatitis B virus, herpes virus, HIV-1, IgE (atopic disease), influenza virus, *Leishmania donovani*, *leptospira*, measles/mumps/rubella, *Mycobacterium leprae*, *Mycoplasma pneumoniae*, Myoglobin, *Onchocerca volvulus*, parainfluenza virus, *Plasmodium falciparum*, poliovirus, *Pseudomonas aeruginosa*, respiratory syncytial virus, *rickettsia* (scrub typhus), *Schistosoma mansoni*, *Toxoplasma gondii*, *Treponema pallidum*, *Trypanosoma cruzi/rangeli*, vesicular stomatis virus, *Wuchereria bancrofti*, yellow fever virus); specific antigens (hepatitis B virus, HIV-1); succinylacetone; sulfadoxine; theophylline; thyrotropin (TSH); thyroxine (T4); thyroxine-binding globulin; trace elements; transferrin; UDP-galactose-4-epimerase; urea; uroporphyrinogen I synthase; vitamin A; white blood cells; and zinc protoporphyrin. Salts, sugar, protein, fat, vitamins, and hormones naturally occurring in blood or interstitial fluids can also constitute analytes in certain embodiments. The analyte can be naturally present in the biological fluid, for example, a metabolic product, a hormone, an antigen, an antibody, and the like. Alternatively, the analyte can be introduced into the body, for example, a contrast agent for imaging, a radioisotope, a chemical agent, a fluorocarbon-based synthetic blood, or a drug or pharmaceutical composition, including but not limited to insulin; ethanol; *cannabis* (marijuana, tetrahydrocannabinol, hashish); inhalants (nitrous oxide, amyl nitrite, butyl nitrite, chlorohydrocarbons, hydrocarbons); cocaine (crack cocaine); stimulants (amphetamines, methamphetamines, Ritalin, Cylert, Preludin, Didrex, PreState, Voranil, Sandrex, Plegine); depressants (barbituates, methaqualone, tranquilizers such as Valium, Librium, Miltown, Serax, Equanil, Tranxene); hallucinogens (phencyclidine, lysergic acid, mescaline, peyote, psilocybin); narcotics (heroin, codeine, morphine, opium, meperidine, Percocet, Percodan, Tussionex, Fentanyl, Darvon, Talwin, Lomotil); designer drugs (analogs of fentanyl, meperidine, amphetamines, methamphetamines, and phencyclidine, for example, Ecstasy); anabolic steroids; and nicotine. The metabolic products of drugs and pharmaceutical compositions are also contemplated analytes. Analytes such as neurochemicals and other chemicals generated within the body can also be analyzed, such as, for example, ascorbic acid, uric acid, dopamine, noradrenaline, 3-methoxytyramine (3MT), 3,4-dihydroxyphenylacetic acid (DOPAC), homovanillic acid (HVA), 5-hydroxytryptamine (5HT), histamine, Advanced Glycation End Products (AGEs) and 5-hydroxyindoleacetic acid (FHIAA).

[0162] The term “host” as used herein is a broad term, and is to be given its ordinary and customary meaning to a person

of ordinary skill in the art (and is not to be limited to a special or customized meaning), and refers without limitation to animals or plants, for example humans.

**[0163]** The term “continuous (or continual) analyte sensing” as used herein is a broad term, and is to be given its ordinary and customary meaning to a person of ordinary skill in the art (and is not to be limited to a special or customized meaning), and refers without limitation to the period in which monitoring of analyte concentration is continuously, continually, and/or intermittently (regularly or irregularly) performed, for example, about every 5 to 10 minutes.

**[0164]** The term “electrochemically reactive surface” as used herein is a broad term, and is to be given its ordinary and customary meaning to a person of ordinary skill in the art (and is not to be limited to a special or customized meaning), and refers without limitation to a surface where an electrochemical reaction takes place. For example, a working electrode measures hydrogen peroxide produced by the enzyme-catalyzed reaction of the analyte detected, which reacts to create an electric current. Glucose analyte can be detected utilizing glucose oxidase, which produces  $H_2O_2$  as a byproduct.  $H_2O_2$  reacts with the surface of the working electrode, producing two protons ( $2H^+$ ), two electrons ( $2e^-$ ) and one molecule of oxygen ( $O_2$ ), which produces the electronic current being detected.

**[0165]** The terms “electronic connection,” “electrical connection,” “electrical contact” as used herein are broad terms, and are to be given their ordinary and customary meaning to a person of ordinary skill in the art (and is not to be limited to a special or customized meaning), and refer without limitation to any connection between two electrical conductors known to those in the art. In one embodiment, electrodes are in electrical connection with the electronic circuitry of a device.

**[0166]** The term “sensing region” as used herein is a broad term, and is to be given its ordinary and customary meaning to a person of ordinary skill in the art (and is not to be limited to a special or customized meaning), and refers without limitation to the region of a monitoring device responsible for the detection of a particular analyte. The sensing region generally comprises a non-conductive body, a working electrode (anode), and can include a reference electrode (optional), and/or a counter electrode (cathode) forming electrochemically reactive surfaces on the body.

**[0167]** The term “domain” as used herein is a broad term, and is to be given its ordinary and customary meaning to a person of ordinary skill in the art (and is not to be limited to a special or customized meaning), and refers without limitation to a region of the membrane system that can be a layer, a uniform or non-uniform gradient (for example, an anisotropic region of a membrane), or a portion of a membrane.

**[0168]** The term “distal to” as used herein is a broad term, and is to be given its ordinary and customary meaning to a person of ordinary skill in the art (and is not to be limited to a special or customized meaning), and refers without limitation to the spatial relationship between various elements in comparison to a particular point of reference. In general, the term indicates an element is located relatively far from the reference point than another element.

**[0169]** The term “proximal to” as used herein is a broad term, and is to be given its ordinary and customary meaning to a person of ordinary skill in the art (and is not to be limited to a special or customized meaning), and refers without limitation to the spatial relationship between various elements in

comparison to a particular point of reference. In general, the term indicates an element is located relatively near to the reference point than another element.

**[0170]** The term “in vivo portion” as used herein is a broad term, and is to be given its ordinary and customary meaning to a person of ordinary skill in the art (and is not to be limited to a special or customized meaning), and refers without limitation to a portion of a device (for example, a sensor) adapted for insertion into and/or existence within a living body of a host.

**[0171]** The term “ex vivo portion” as used herein is a broad term, and is to be given its ordinary and customary meaning to a person of ordinary skill in the art (and is not to be limited to a special or customized meaning), and refers without limitation to a portion of a device (for example, a sensor) adapted to remain and/or exist outside of a living body of a host.

**[0172]** The terms “raw data,” “raw data stream,” “raw data signal”, and “data stream” as used herein are broad terms, and are to be given their ordinary and customary meaning to a person of ordinary skill in the art (and are not to be limited to a special or customized meaning), and refer without limitation to an analog or digital signal from the analyte sensor directly related to the measured analyte. For example, the raw data stream is digital data in “counts” converted by an A/D converter from an analog signal (for example, voltage or amps) representative of an analyte concentration. The terms can include a plurality of time spaced data points from a substantially continuous analyte sensor, each of which comprises individual measurements taken at time intervals ranging from fractions of a second up to, for example, 1, 2, or 5 minutes or longer. In some embodiments, the terms can refer to data that has been integrated or averaged over a time period (e.g., 5 minutes).

**[0173]** The term “count” as used herein is a broad term, and is to be given its ordinary and customary meaning to a person of ordinary skill in the art (and is not to be limited to a special or customized meaning), and refers without limitation to a unit of measurement of a digital signal. For example, a raw data stream or raw data signal measured in counts is directly related to a voltage (for example, converted by an A/D converter), which is directly related to current from the working electrode. In some embodiments, the terms can refer to data that has been integrated or averaged over a time period (e.g., 5 minutes).

**[0174]** The terms “sensor” and “sensor system” as used herein are broad terms, and are to be given their ordinary and customary meaning to a person of ordinary skill in the art (and are not to be limited to a special or customized meaning), and refer without limitation to a device, component, or region of a device by which an analyte can be quantified.

**[0175]** The term “needle” as used herein is a broad term, and is to be given its ordinary and customary meaning to a person of ordinary skill in the art (and is not to be limited to a special or customized meaning), and refers without limitation to a slender hollow instrument for introducing material into or removing material from the body.

**[0176]** The terms “operatively connected,” “operatively linked,” “operably connected,” and “operably linked” as used herein are broad terms, and are to be given their ordinary and customary meaning to a person of ordinary skill in the art (and are not to be limited to a special or customized meaning), and refer without limitation to one or more components linked to one or more other components. The terms can refer to a mechanical connection, an electrical connection, or any con-

nection that allows transmission of signals between the components. For example, one or more electrodes can be used to detect the amount of analyte in a sample and to convert that information into a signal; the signal can then be transmitted to a circuit. In such an example, the electrode is “operably linked” to the electronic circuitry. The terms include wired and wireless connections.

**[0177]** The terms “membrane” and “membrane system” as used herein are broad terms, and are to be given their ordinary and customary meaning to a person of ordinary skill in the art (and are not to be limited to a special or customized meaning), and refer without limitation to a permeable or semi-permeable membrane that can be comprised of one or more domains and is typically constructed of materials of one or more microns in thickness, which is permeable to oxygen and to an analyte, e.g., glucose or another analyte. In one example, the membrane system comprises an immobilized glucose oxidase enzyme, which enables a reaction to occur between glucose and oxygen whereby a concentration of glucose can be measured.

**[0178]** The terms “processor module” and “microprocessor” as used herein are broad terms, and are to be given their ordinary and customary meaning to a person of ordinary skill in the art (and are not to be limited to a special or customized meaning), and refer without limitation to a computer system, state machine, processor, and the like designed to perform arithmetic or logic operations using logic circuitry that responds to and processes the basic instructions that drive a computer.

**[0179]** The term “calibration” as used herein is a broad term, and is to be given its ordinary and customary meaning to a person of ordinary skill in the art (and is not to be limited to a special or customized meaning), and refers without limitation to the relationship and/or process of determining the relationship between the sensor data and the corresponding reference data, which can be used to convert sensor data into values substantially equivalent to the reference data. In some embodiments, namely, in continuous analyte sensors, calibration can be updated or recalibrated over time if changes in the relationship between the sensor data and reference data occur, for example, due to changes in sensitivity, baseline, transport, metabolism, and the like.

**[0180]** The terms “interferents” and “interfering species” as used herein are broad terms, and are to be given their ordinary and customary meaning to a person of ordinary skill in the art (and are not to be limited to a special or customized meaning), and refer without limitation to effects and/or species that interfere with the measurement of an analyte of interest in a sensor to produce a signal that does not accurately represent the analyte concentration. In one example of an electrochemical sensor, interfering species are compounds with an oxidation potential that substantially overlaps that of the analyte to be measured, thereby producing a false positive signal.

**[0181]** The term “single point glucose monitor” as used herein is a broad term, and is to be given its ordinary and customary meaning to a person of ordinary skill in the art (and is not to be limited to a special or customized meaning), and refers without limitation to a device that can be used to measure a glucose concentration within a host at a single point in time, for example, some embodiments utilize a small volume in vitro glucose monitor that includes an enzyme membrane such as described with reference to U.S. Pat. No. 4,994,167 and U.S. Pat. No. 4,757,022. It should be understood that

single point glucose monitors can measure multiple samples (for example, blood, or interstitial fluid); however only one sample is measured at a time and typically requires some user initiation and/or interaction.

**[0182]** The term “biological sample” as used herein is a broad term, and is to be given its ordinary and customary meaning to a person of ordinary skill in the art (and is not to be limited to a special or customized meaning), and refers without limitation to sample of a host body, for example blood, interstitial fluid, spinal fluid, saliva, urine, tears, sweat, tissue, fat, and the like.

**[0183]** The terms “substantial” and “substantially” as used herein are broad terms, and are to be given their ordinary and customary meaning to a person of ordinary skill in the art (and are not to be limited to a special or customized meaning), and refer without limitation to a sufficient amount that provides a desired function. For example, an amount greater than 50 percent, an amount greater than 60 percent, an amount greater than 70 percent, an amount greater than 80 percent, or an amount greater than 90 percent.

**[0184]** The term “casting” as used herein is a broad term, and is to be given its ordinary and customary meaning to a person of ordinary skill in the art (and is not to be limited to a special or customized meaning), and refers without limitation to a process where a fluid material is applied to a surface or surfaces and allowed to cure or dry. The term is broad enough to encompass a variety of coating techniques, for example, using a draw-down machine (i.e., drawing-down), dip coating, spray coating, spin coating, and the like.

**[0185]** The term “dip coating” as used herein is a broad term, and is to be given its ordinary and customary meaning to a person of ordinary skill in the art (and is not to be limited to a special or customized meaning), and refers without limitation to coating, which involves dipping an object or material into a liquid coating substance.

**[0186]** The term “spray coating” as used herein is a broad term, and is to be given its ordinary and customary meaning to a person of ordinary skill in the art (and is not to be limited to a special or customized meaning), and refers without limitation to coating, which involves spraying a liquid coating substance onto an object or material.

**[0187]** The term “spin coating” as used herein is a broad term, and is to be given its ordinary and customary meaning to a person of ordinary skill in the art (and is not to be limited to a special or customized meaning), and refers without limitation to a coating process in which a thin film is created by dropping a raw material solution onto a substrate while it is rotating.

**[0188]** The terms “solvent” and “solvent system” as used herein are broad terms, and are to be given their ordinary and customary meaning to a person of ordinary skill in the art (and are not to be limited to a special or customized meaning), and refer without limitation to substances (e.g., liquids) capable of dissolving or dispersing one or more other substances. Solvents and solvent systems can include compounds and/or solutions that include components in addition to the solvent itself.

**[0189]** The terms “baseline,” “noise” and “background signal” as used herein are broad terms, and are to be given their ordinary and customary meaning to a person of ordinary skill in the art (and is not to be limited to a special or customized meaning), and refer without limitation to a component of an analyte sensor signal that is not related to the analyte concentration. In one example of a glucose sensor, the baseline is

composed substantially of signal contribution due to factors other than glucose (for example, interfering species, non-reaction-related hydrogen peroxide, or other electroactive species with an oxidation potential that overlaps with hydrogen peroxide). In some embodiments wherein a calibration is defined by solving for the equation  $y=m \times b$ , the value of  $b$  represents the baseline, or background, of the signal.

**[0190]** The terms “sensitivity” and “slope” as used herein are broad terms, and are to be given their ordinary and customary meaning to a person of ordinary skill in the art (and are not to be limited to a special or customized meaning), and refer without limitation to an amount of electrical current produced by a predetermined amount (unit) of the measured analyte. For example, in one preferred embodiment, a glucose sensor has a sensitivity (or slope) of about 3.5 to about 7.5 picoAmps of current for every 1 mg/dL of glucose.

**[0191]** The terms “baseline and/or sensitivity shift,” “baseline and/or sensitivity drift,” “shift,” and “drift” as used herein are broad terms, and are to be given their ordinary and customary meaning to a person of ordinary skill in the art (and are not to be limited to a special or customized meaning), and refer without limitation to a change in the baseline and/or sensitivity of the sensor signal over time. While the term “shift” generally refers to a substantially distinct change over a relatively short time period, and the term “drift” generally refers to a substantially gradual change over a relatively longer time period, the terms can be used interchangeably and can also be generally referred to as “change” in baseline and/or sensitivity.

**[0192]** The term “hypoglycemia” as used herein is a broad term, and is to be given its ordinary and customary meaning to a person of ordinary skill in the art (and are not to be limited to a special or customized meaning), and refers without limitation to a condition in which a limited or low amount of glucose exists in a host. Hypoglycemia can produce a variety of symptoms and effects but the principal problems arise from an inadequate supply of glucose as fuel to the brain, resulting in impairment of function (neuroglycopenia). Derangements of function can range from vaguely “feeling bad” to coma, and (rarely) permanent brain damage or death.

**[0193]** The term “hyperglycemia” as used herein is a broad term, and is to be given its ordinary and customary meaning to a person of ordinary skill in the art (and are not to be limited to a special or customized meaning), and refers without limitation to a condition in which an excessive or high amount of glucose exists in a host. Hyperglycemia is one of the classic symptoms of diabetes mellitus. Non-diabetic hyperglycemia is associated with obesity and certain eating disorders, such as bulimia nervosa. Hyperglycemia is also associated with other diseases (or medications) affecting pancreatic function, such as pancreatic cancer. Hyperglycemia is also associated with poor medical outcomes in a variety of clinical settings, such as intensive or critical care settings.

**[0194]** The term “potentiostat” as used herein is a broad term, and is to be given its ordinary and customary meaning to a person of ordinary skill in the art (and is not to be limited to a special or customized meaning), and refers without limitation to an electronic instrument that controls the electrical potential between the working and reference electrodes at one or more preset values. Typically, a potentiostat works to keep the potential constant by noticing changes in the resistance of the system and compensating inversely with a change in the current. As a result, a change to a higher resistance would cause the current to decrease to keep the voltage constant in

the system. In some embodiments, a potentiostat forces whatever current is necessary to flow between the working and counter electrodes to keep the desired potential, as long as the needed cell voltage and current do not exceed the compliance limits of the potentiostat.

**[0195]** The terms “electronics” and “sensor electronics” as used herein are broad terms, and are to be given their ordinary and customary meaning to a person of ordinary skill in the art (and are not to be limited to a special or customized meaning), and refer without limitation to electronics operatively coupled to the sensor and configured to measure, process, receive, and/or transmit data associated with a sensor. In some embodiments, the electronics include at least a potentiostat that provides a bias to the electrodes and measures a current to provide the raw data signal. The electronics are configured to calculate at least one analyte sensor data point. For example, the electronics can include a potentiostat, A/D converter, RAM, ROM, and/or transmitter. In some embodiments, the potentiostat converts the raw data (e.g., raw counts) collected from the sensor and converts it to a value familiar to the host and/or medical personnel. For example, the raw counts from a glucose sensor can be converted to milligrams of glucose per deciliter of blood (e.g., mg/dl). In some embodiments, the sensor electronics include a transmitter that transmits the signals from the potentiostat to a receiver, where additional data analysis and glucose concentration determination can occur.

**[0196]** The terms “coupling” and “operatively coupling” as used herein are broad terms, and are to be given their ordinary and customary meanings to a person of ordinary skill in the art (and are not to be limited to a special or customized meaning), and refer without limitation to a joining or linking together of two or more things, such as two parts of a device or two devices, such that the things can function together. In one example, two containers can be operatively coupled by tubing, such that fluid can flow from one container to another. Coupling does not imply a physical connection. For example, a transmitter and a receiver can be operatively coupled by radio frequency (RF) transmission/communication.

**[0197]** The term “fluid communication” as used herein is a broad term, and is to be given its ordinary and customary meaning to a person of ordinary skill in the art (and are not to be limited to a special or customized meaning), and refers without limitation to two or more components (e.g., things such as parts of a body or parts of a device) functionally linked such that fluid can move from one component to another. These terms do not imply directionality.

**[0198]** The terms “continuous” and “continuously” as used herein are broad terms, and are to be given their ordinary and customary meanings to a person of ordinary skill in the art (and are not to be limited to a special or customized meaning), and refer without limitation to the condition of being marked by substantially uninterrupted extension in space, time or sequence. In one embodiment, an analyte concentration is measured continuously or continually, for example at time intervals ranging from fractions of a second up to, for example, 1, 2, or 5 minutes, or longer. It should be understood that continuous glucose sensors generally continually measure glucose concentration without required user initiation and/or interaction for each measurement, such as described with reference to U.S. Pat. No. 6,001,067, for example. These terms include situations wherein data gaps can exist (e.g., when a continuous glucose sensor is temporarily not providing data).

**[0199]** The term “medical device” as used herein is a broad term, and is to be given its ordinary and customary meaning to a person of ordinary skill in the art (and are not to be limited to a special or customized meaning), and refers without limitation to an instrument, apparatus, implement, machine, contrivance, implant, in vitro reagent, or other similar or related article, including a component part, or accessory which is intended for use in the diagnosis of disease or other conditions, or in the cure, mitigation, treatment, or prevention of disease, in man or other animals, or intended to affect the structure or any function of the body of man or other animals. Medical devices that can be used in conjunction with various embodiments of the analyte sensor system include any monitoring device requiring placement in a human vessel, duct or body cavity, a dialysis machine, a heart-lung bypass machine, blood collection equipment, a blood pressure monitor, an automated blood chemistry analysis device and the like.

**[0200]** The term “blood pressure monitor” as used herein is a broad term, and is to be given its ordinary and customary meaning to a person of ordinary skill in the art (and are not to be limited to a special or customized meaning), and refers without limitation to an instrument for monitoring the blood pressure of a human or other animal. For example, a blood pressure monitor can be an invasive blood pressure monitor, which periodically monitors the host’s blood pressure via a peripheral artery, using a blood pressure transducer, such as but not limited to a disposable blood pressure transducer. Utah Medical Products Inc. (Midvale, Utah, USA) produces a variety of Deltran® Brand disposable blood pressure transducers that are suitable for use with various embodiments disclosed herein.

**[0201]** The term “pressure transducer” as used herein is a broad term, and is to be given its ordinary and customary meaning to a person of ordinary skill in the art (and are not to be limited to a special or customized meaning), and refers without limitation to a component of an intra-arterial blood pressure monitor that measures the host’s blood pressure.

**[0202]** The term “blood chemistry analysis device” as used herein is a broad term, and is to be given its ordinary and customary meaning to a person of ordinary skill in the art (and are not to be limited to a special or customized meaning), and refers without limitation to a device that measures a variety of blood components, characteristics or analytes therein. In one embodiment, a blood chemistry analysis device periodically withdraws an aliquot of blood from the host, measures glucose, O<sub>2</sub>, CO<sub>2</sub>, PCO<sub>2</sub>, PO<sub>2</sub>, potassium, sodium, pH, lactate, urea, bilirubin, creatinine, hematocrit, various minerals, and/or various metabolites, and the like, and returns the blood to the host’s circulatory system. A variety of devices exist for testing various blood properties/analytes at the bedside, such as but not limited to the blood gas and chemistry devices manufactured by Via Medical (Austin, Tex., USA).

**[0203]** The term “vascular access device” as used herein is a broad term, and is to be given its ordinary and customary meaning to a person of ordinary skill in the art (and are not to be limited to a special or customized meaning), and refers without limitation to any device that is in communication with the vascular system of a host. Vascular access devices include but are not limited to catheters, shunts, blood withdrawal devices and the like.

**[0204]** The term “catheter” as used herein is a broad term, and is to be given its ordinary and customary meaning to a person of ordinary skill in the art (and are not to be limited to a special or customized meaning), and refers without limita-

tion to a tube that can be inserted into a host’s body (e.g., cavity, duct or vessel). In some circumstances, catheters allow drainage or injection of fluids or access by medical instruments or devices. In some embodiments, a catheter is a thin, flexible tube (e.g., a “soft” catheter). In alternative embodiments, the catheter can be a larger, solid tube (e.g., a “hard” catheter). The term “cannula” is interchangeable with the term “catheter” herein.

**[0205]** The term “indwell” as used herein is a broad term, and is to be given its ordinary and customary meaning to a person of ordinary skill in the art (and are not to be limited to a special or customized meaning), and refers without limitation to reside within a host’s body. Some medical devices can indwell within a host’s body for various lengths of time, depending upon the purpose of the medical device, such as but not limited to a few hours, days, weeks, to months, years, or even the host’s entire lifetime. In one exemplary embodiment, an arterial catheter may indwell within the host’s artery for a few hours, days, a week, or longer, such as but not limited to the host’s perioperative period (e.g., from the time the host is admitted to the hospital to the time he is discharged).

**[0206]** The term “sheath” as used herein is a broad term, and is to be given its ordinary and customary meaning to a person of ordinary skill in the art (and are not to be limited to a special or customized meaning), and refers without limitation to a covering or supporting structure that fits closely around something, for example, in the way that a sheath covers a blade. In one exemplary embodiment, a sheath is a slender, flexible, polymer tube that covers and supports a wire-type sensor prior to and during insertion of the sensor into a catheter.

**[0207]** The term “slot” as used herein is a broad term, and is to be given its ordinary and customary meaning to a person of ordinary skill in the art (and are not to be limited to a special or customized meaning), and refers without limitation to a relatively narrow opening.

#### Overview

**[0208]** Intensive care medicine or critical care medicine is concerned with providing greater than ordinary medical care and/or observation to people in a critical or unstable condition. In recent years, an increasingly urgent need has arisen, for more intensive care medicine. People requiring intensive care include those recovering after major surgery, with severe head trauma, life-threatening acute illness, respiratory insufficiency, coma, haemodynamic insufficiency, severe fluid imbalance or with the failure of one or more of the major organ systems (life-critical systems or others). More than 5 million people are admitted annually to intensive care units (ICUs) and critical care units (CCUs) in the United States.

**[0209]** Intensive care is generally the most expensive, high technology and resource intensive area of medical care. In the United States estimates of the year 2000 expenditure for critical care medicine ranged from \$15-55 billion accounting for about 0.5% of GDP and about 13% of national health care expenditure. As the U.S. population ages, these costs will increase substantially. Accordingly, there is an urgent need to reducing costs while at the same time reducing ICU/CCU mortality rates by improving care. Some embodiments disclosed herein are suitable for use in an intensive care or critical care unit of a medical care facility for substantially continuously measuring a host’s analyte concentration.

**[0210]** Hyperglycemia is a medical condition in which an excessive amount of glucose circulates in a host. Medical studies suggest a relationship between hyperglycemia and host outcome in intensive/critical care settings. For example, perioperative hyperglycemia is associated with increased rates and severity of myocardial infarction (MI) and stroke, while tight glucose control with intravenous (IV) insulin therapy is linked to a 30% reduction in mortality one year after admission for acute MI. Furthermore, strict in-hospital glucose control is associated with 40% reductions of morbidity, mortality, sepsis, dialysis, blood transfusions, as well as reduced length of stay, reduced costs and the like.

**[0211]** Hyperglycemia can also be an issue in non-critical care settings, such as in the general hospital population, such as for diabetes hosts admitted for non-glucose-related medical conditions, or in clinical settings, such as the doctor's office, such as during glucose challenge tests, or treatment of the elderly or the very young, or others who may have difficulty with glucose control.

**[0212]** Unfortunately, using generally available technology, tight glucose control requires frequent monitoring of the host by the clinical staff, IV insulin or injections, and on-time feeding. Frequent monitoring typically requires a nurse or other staff member to measure the host's glucose concentration using a lancet (to obtain a blood sample) and a hand held glucose monitor. The nurse can perform this task many times a day (e.g., every hour or more frequently). This task becomes an undue burden that takes the nurse away from his/her other duties, or requires extra staff. The preferred embodiments disclose systems and methods to reduce and/or minimize the interaction required to regularly (e.g., continuously) measure the host's glucose concentration.

**[0213]** Unfortunately it has been shown that an effort to maintain tight control of glucose levels (e.g., about 80-129 mg/dl) can increase the risk of hypoglycemia using conventional systems and methods. For example, administration of insulin, quality, and timing of meal ingestion, and the like can lead to hypoglycemia. Because hypoglycemia can cause shock and death (immediate problems), the clinical staff rigorously avoids it, often by maintaining the host at elevated blood glucose concentrations (which can degrade the clinical outcome in the long run) and causes the problems of hyperglycemia discussed above.

**[0214]** Accordingly, in spite of clinically demonstrated improvements associated with tight glucose control, institutions are slow to adopt the therapy due to the increased workload on the staff as well as a pervasive fear of hypoglycemia, which is potentially life ending. Therefore, there is an urgent need for devices and methods that offer continuous, robust glucose monitoring, to improve patient care and lower medical costs. The preferred embodiments describe systems and methods for providing continuous glucose monitoring while providing alarms or alerts that aid in avoiding hypoglycemic events.

**[0215]** Hyperglycemia can be managed in a variety of ways. Currently, for hosts in an intensive care setting, such as and ICU, CCU or emergency room (ER), hyperglycemia is managed with sliding-scale IV insulin, that stops insulin delivery at about 150 to 200 mg/dl. This generally requires monitoring by a nurse (using a hand-held clinical glucose meter) and insulin administration at least every six hours. Maintaining tight glucose control within the normal range (e.g., 80-110 mg/dl) currently requires hourly or even more frequent monitoring and insulin administration. This places

an undue burden on the nursing staff. The preferred embodiments provide devices and methods for automated, continuous glucose monitoring (e.g., indwelling in the circulatory system), to enable tight glucose control.

**[0216]** The in vivo continuous analyte monitoring system of the preferred embodiments can be used in clinical settings, such as in the hospital, the doctor's office, long-term nursing facilities, or even in the home. The present device can be used in any setting in which frequent or continuous analyte monitoring is desirable. For example, in the ICU, hosts are often recovering from serious illness, disease, or surgery, and control of host glucose levels is important for host recovery. Use of an in-dwelling continuous glucose monitor allows tight control of host glucose concentration and improved host care, while reducing hypoglycemic episodes and reducing the ICU staff work load. For example, the system can be used for the entire hospital stay or for only a part of the hospital stay.

**[0217]** In another example, the in-dwelling continuous glucose monitor can be used in an ER setting. In the ER, a host may be unable to communicate with the staff. Routine use of a continuous analyte monitor (e.g., glucose, creatinine, phosphate, electrolytes, or drugs) can enable the ER staff to monitor and respond to analyte concentration changes indicative of the host's condition (e.g., the host's glucose concentration) without host input.

**[0218]** In yet another example, a continuous analyte monitor can be used in the general hospital population to monitor host analyte concentrations, for various lengths of time, such as during the entire hospital stay or for a portion of the hospital stay (e.g., only during surgery). For example, a diabetic host's glucose concentration can be monitored during his entire stay. In another example, a cardiac host's glucose can be monitored during surgery and while in the ICU, but not after being moved to the general host population. In another example, a jaundiced newborn infant can have his bilirubin concentration continuously monitored by an in-dwelling continuous analyte monitor until the condition has receded.

**[0219]** In addition to use in the circulatory system, the analyte sensor of the preferred embodiments can be used in other body locations. In some embodiments, the sensor is used subcutaneously. In another embodiment, the sensor can be used intracranially. In another embodiment, the sensor can be used within the spinal compartment, such as but not limited to the epidural space. In some embodiments, the sensor of the preferred embodiments can be used with or without a catheter.

#### Applications/Uses

**[0220]** One aspect of the preferred embodiments provides a system for in vivo continuous analyte monitoring (e.g., glucose, O<sub>2</sub>, CO<sub>2</sub>, PCO<sub>2</sub>, PO<sub>2</sub>, potassium, sodium, pH, lactate, urea, bilirubin, creatinine, hematocrit, various minerals, various metabolites, and the like) that can be operatively coupled to a catheter to measure analyte concentration within the host's blood stream. In some embodiments, the system includes an analyte sensor that extends a short distance into the blood stream (e.g., out of the catheter) without substantially occluding the catheter or the host's blood stream. The catheter can be fluidly coupled to additional IV and diagnostic devices, such as a saline bag, an automated blood pressure monitor, or a blood chemistry monitor device. In some embodiments, blood samples can be removed from the host via the sensor system, as described elsewhere herein. In one

embodiment, the sensor is a glucose sensor, and the medical staff monitors the host's glucose level.

**[0221]** FIGS. 1A to 1E illustrate one embodiment of an exemplary analyte sensor system **10** for measuring an analyte (e.g., glucose, urea, potassium, pH, proteins, etc.) that includes a catheter **12** configured to be inserted or pre-inserted into a host's blood stream. In clinical settings, catheters are often inserted into hosts to allow direct access to the circulatory system without frequent needle insertion (e.g., venipuncture). Suitable catheters can be sized as is known and appreciated by one skilled in the art, such as but not limited to from about 1 French (0.33 mm) or less to about 30 French (10 mm) or more; and can be, for example, 2, 3, 4, 5, 6, 7, 8, 9, 10, 11, 12, 13, 14, 15, 16, 17, 18, 19, or 20 French (3 French is equivalent to about 1 mm). The catheter can be manufactured of any medical grade material known in the art, such as but not limited to polymers and glass as described herein. A catheter can include a single lumen or multiple lumens. A catheter can include one or more perforations, to allow the passage of host fluid through the lumen of the catheter.

**[0222]** The terms "inserted" or "pre-inserted" as used herein are broad terms, and are to be given their ordinary and customary meaning to a person of ordinary skill in the art (and are not to be limited to a special or customized meaning), and refer without limitation to insertion of one thing into another thing. For example, a catheter can be inserted into a host's blood stream. In some embodiments, a catheter is "pre-inserted," meaning inserted before another action is taken (e.g., insertion of a catheter into a host's blood stream prior to insertion of a sensor into the catheter). In some exemplary embodiments, a sensor is coupled to a pre-inserted catheter, namely, one that has been previously inserted (or pre-inserted) into the host's circulatory system.

**[0223]** Referring now to FIGS. 1A to 1E, in some embodiments, the catheter **12** is a thin, flexible tube having a lumen **12a**, such as is known in the art. In some embodiments, the catheter can be rigid; in other embodiments, the catheter can be custom manufactured to desired specifications (e.g., rigidity, dimensions, etc). The catheter can be a single-lumen catheter or a multi-lumen catheter. At the catheter's proximal end is a small orifice **12b** for fluid connection of the catheter to the blood stream. At the catheter's distal end is a connector **18**, such as a leuc connector or other fluid connector known in the art.

**[0224]** The illustrations FIGS. 1A to 1E show one exemplary embodiment of the connector **18** including a flange **18a** and a duct **18b**. In the exemplary embodiment, the flange **18a** is configured to enable connection of the catheter to other medical equipment (e.g., saline bag, pressure transducer, blood chemistry device, and the like) or capping (e.g., with a bung and the like). Although one exemplary connector is shown, one skilled in the art appreciates a variety of standard or custom made connectors suitable for use with the preferred embodiments. The duct **18b** is in fluid communication with the catheter lumen and terminates in a connector orifice **18c**.

**[0225]** In some embodiments, the catheter is inserted into the host's blood stream, such as into a vein or artery by any useful method known in the art. Generally, prior to and during insertion, the catheter is supported by a hollow needle or trochar (not shown). For example, the supported catheter can be inserted into a peripheral vein or artery, such as in the host's arm, leg, hand, or foot. Typically, the supporting needle is removed (e.g., pulled out of the connector) and the catheter is connected (e.g., via the connector **18**) to IV tubing and a

saline drip, for example. However, in one embodiment, the catheter is configured to operatively couple to medical equipment, such as but not limited to a sensor system of the preferred embodiments. Additionally and/or alternatively, the catheter can be configured to operatively couple to another medical device, such as a pressure transducer, for measurement of the host's blood pressure.

**[0226]** In some embodiments, the catheter and the analyte sensor are configured to indwell within the host's blood stream in vivo. An indwelling medical device, such as a catheter or implant, is disposed within a portion of the body for a period of time, from a few minutes or hours to a few days, months, or even years. An indwelling catheter is typically inserted within a host's vein or artery for a period of time, often 2 or more days, a month, or even a few months. In some embodiments, the catheter can indwell in a host's artery or vein for the length of a perioperative period (e.g., the entire hospital stay) or for shorter or longer periods. In some embodiments, the use of an indwelling catheter permits continuous access of an analyte sensor to a blood stream while simultaneously allowing continuous access to the host's blood stream for other purposes, for example, the administration of therapeutics (e.g., fluids, drugs, etc.), measurement of physiologic properties (e.g., blood pressure), fluid removal, and the like.

**[0227]** Referring again to FIGS. 1A to 1E, the system **10** also includes an analyte sensor **14** configured to extend through the catheter lumen **12a** (see FIG. 1E), out of the catheter orifice **12b** and into the host's blood stream by about 0.010 inches to about 1 inch, or shorter or longer lengths. In some embodiments, however, the sensor may not extend out of the catheter, for example, can reside just inside the catheter tip. The sensor can extend through the catheter in any functional manner. In some embodiments, the sensor is configured to be held on an inner surface (e.g., the lumen) or outer surface of the catheter, while in other embodiments, the sensor is configured to "free float" within the lumen of the catheter.

**[0228]** In some embodiments, the sensor **14** is configured to measure the concentration of an analyte (e.g., glucose, O<sub>2</sub>, CO<sub>2</sub>, PCO<sub>2</sub>, PO<sub>2</sub>, potassium, sodium, pH, lactate, urea, bilirubin, creatinine, hematocrit, various minerals, various metabolites, and the like) within the host's blood stream. Preferably, the sensor includes at least one electrode (see, e.g., FIG. 3B), for example a working electrode; however any combination of working electrode(s), reference electrode(s), and/or counter electrode(s) can be implemented as is appreciated by one skilled in the art. Preferably, the sensor **14** includes at least one exposed electroactive area (e.g., working electrode), a membrane system (e.g., including an enzyme), a reference electrode (proximal to or remote from the working electrode), and an insulator material. Various systems and methods for design and manufacture of continuous analyte sensors are described in more detail elsewhere herein. In some embodiments, the sensor is a needle-type continuous analyte sensor, configured as disclosed in U.S. publication US 2006-0020192 and/or U.S. publication US 2006-0036143, both of which are incorporated herein by reference in their entirety. In some embodiments, the sensor is configured to measure glucose concentration. Exemplary sensor configurations are discussed in more detail, elsewhere herein.

**[0229]** Referring to FIGS. 1A to 1E, the sensor has a proximal end **14a** and a distal end **14b**. At its distal end **14b**, the sensor **14** is associated with (e.g., connected to, held by, extends through, and the like) a fluid coupler **20** having first

and second sides (20a and 20b, respectively). The fluid coupler is configured to mate (via its first side 20a) to the catheter connector 18. In one embodiment, a skirt 20c is located at the fluid coupler's first side and includes an interior surface 20d with threads 20e (see FIGS. 1D and 1E). In this embodiment, the fluid coupler is configured to mate with the connector flange 18a, which is screwed into the fluid coupler via the screw threads. However, in other embodiments, the fluid coupler is configured to mate with the connector using any known mating configuration, for example, a snap-fit, a press-fit, an interference-fit, and the like, and can include a locking mechanism to prevent separation of the connector and fluid coupler. The fluid coupler 20 includes a lumen 20f extending from a first orifice 20h on its first side 20a to a second orifice 20i located on the fluid coupler's second side 20b (FIGS. 1C1 to 1E). When the catheter connector is mated with the fluid coupler, the catheter's lumen 12a is in fluid communication with the fluid coupler's lumen 20f via orifices 18c and 20h.

[0230] FIGS. 1A to 1D show one embodiment of a fluid coupler 20, namely, a Y-coupler; however, any known coupler configuration can be used, including but not limited to a straight coupler, a T-coupler, a cross-coupler, a custom configured coupler, and the like. In some embodiments, the fluid coupler includes at least one valve (e.g., a septum, a 3-way valve, a stop-cock valve), which can be used for a variety of purposes (e.g., injection of drugs). The fluid coupler can be made of any convenient material, such as but not limited to plastic, glass, metal or combinations thereof and can be configured to withstand known sterilization techniques.

[0231] In the exemplary embodiment, the second side 20b of the fluid coupler 20 is configured to be operably connected to IV equipment, another medical device or to be capped, and can use any known mating configuration, for example, a snap-fit, a press-fit, an interference-fit, and the like. In one exemplary embodiment, the second side 20b is configured to mate with a saline drip, for delivery of saline to the host. For example, the saline flows from an elevated bag of sterile saline via tubing, through the fluid coupler, through the catheter and into the host's blood system (e.g., vein or artery). In another embodiment, a syringe can be mated to the fluid coupler, for example, to withdraw blood from the host, via the catheter. Additional connection devices (e.g., a three-way valve) can be operably connected to the fluid coupler, to support additional functionality and connection of various devices, such as but not limited to a blood pressure transducer.

[0232] Referring to the exemplary embodiment of FIGS. 1A and 1E, at least a portion of the sensor 14 passes through the fluid coupler 20 (e.g., the fluid coupler lumen 20f) and is operatively connected to sensor electronics (not shown) via a hardwire 24. In alternative embodiments however, the sensor electronics can be disposed in part or in whole with the fluid coupler (e.g., integrally with or proximal to) or can be disposed in part or in whole remotely from the fluid coupler (e.g., on a stand or at the bed side). Connections between the sensor and sensor electronics (in part or in whole) can be accomplished using known wired or wireless technology. In one exemplary embodiment, the sensor is hardwired to the electronics located substantially wholly remote from the fluid coupler (e.g., disposed on a stand or near the bedside); one advantage of remote electronics includes enabling a smaller sized fluid coupler design. In another exemplary embodiment, a portion of the sensor electronics, such as a potentiostat, is disposed on the fluid coupler and the remaining electronics (e.g., electronics for receiving, data processing,

printing, connection to a nurses' station, etc.) are disposed remotely from the fluid coupler (e.g., on a stand or near the bedside). One advantage of this design can include more reliable electrical connection with the sensor in some circumstances. In this embodiment, the potentiostat can be hardwired directly to the remaining electronics or a transmitter can be disposed on or proximal to the fluid coupler, for remotely connecting the potentiostat to the remaining electronics (e.g., by radio frequency (RF)). In another exemplary embodiment, all of the sensor electronics can be disposed on the fluid coupler. In still another embodiment, the sensor electronics disposed on the fluid coupler include a potentiostat.

[0233] Referring again to FIGS. 1A to 1E, a protective sheath 26 is configured to cover at least a portion of the sensor 14 during insertion, and includes hub 28 and slot 30. In general, the protective sheath protects and supports the sensor prior to and during insertion into the catheter 12 via the connector 18. The protective sheath can be made of biocompatible polymers known in the art, such as but not limited to polyethylene (PE), polyurethane (PE), polyvinyl chloride (PVC), polycarbonate (PC), nylon, polyamides, polyimide, polytetrafluoroethylene (PTFE), Teflon, nylon and the like. The protective sheath includes a hub 28, for grasping the sheath (e.g., while maintaining sterilization of the sheath). In this embodiment, the hub additionally provides for mating with the second side 20b of the fluid coupler 20, prior to and during sensor insertion into the catheter. In this exemplary embodiment, the slot of the protective sheath is configured to facilitate release of the sensor therefrom. In this embodiment, after the sensor has been inserted into the catheter, the hub is grasped and pulled from the second side of the fluid coupler. This action peels the protective sheath from the sensor (e.g., the sensor slides through the slot as the sheath is removed), leaving the sensor within the catheter. The second side of the fluid coupler can be connected to other medical devices (e.g., a blood pressure monitor) or an IV drip (e.g., a saline drip), or capped. In alternative embodiments, the sheath can fold (e.g., fold back or concertinas) or retract (e.g., telescope) during insertion, to expose the sensor. In other embodiments, the sheath can be configured to tear away from the sensor before, during, or after insertion of the sensor. In still other embodiments, the sheath can include an outlet hole 30a, to allow protrusion of the sensor from the back end of the sheath (e.g., near the hub 28). One skilled in the art will recognize that additional configurations can be used, to separate the sensor 14 from the sheath 26.

[0234] In some embodiments, the sheath 26 can be optional, depending upon the sensor design. For example, the sensor can be inserted into a catheter or other vascular access device with or without the use of a protective sheath. In some embodiments, the sensor can be disposed on the outer surface of a catheter (as described elsewhere herein) or on the inner surface of a catheter; and no sheath is provided. In other embodiments, a multi-lumen catheter can be provided with a sensor already disposed within one of the lumens; wherein the catheter is inserted into the host's vein or artery with the sensor already disposed in one of the lumens.

[0235] In some alternative embodiments, an analyte sensor is integrally formed on a catheter. In various embodiments, the catheter can be placed into a host's vein or artery in the usual way a catheter is inserted, as is known by one skilled in the art, and the host's analyte concentration measured substantially continuously. In some embodiments, the sensor



system can be coupled to one or more additional devices, such as a saline bag, an automated blood pressure monitor, a blood chemistry monitor device, and the like. In one exemplary embodiment, the integrally formed analyte sensor is a glucose sensor.

**[0236]** FIGS. 2A to 2B illustrate one exemplary embodiment of an analyte sensor integrally formed on a catheter. The system 210 is configured to measure an analyte (e.g., glucose, O<sub>2</sub>, CO<sub>2</sub>, PCO<sub>2</sub>, PO<sub>2</sub>, potassium, sodium, pH, lactate, urea, bilirubin, creatinine, hematocrit, various minerals, various metabolites, and the like) and generally includes a catheter 212 configured for insertion into a host's blood stream (e.g., via a vein or artery) and a sensor at least partially integrally formed on the catheter's exterior surface 232. Preferably, the sensor 214 includes at least one exposed electroactive area 240 (e.g., a working electrode), a membrane system (e.g., including an enzyme), a reference electrode (proximal to or remote from the working electrode), and an insulator. Various systems and methods for design and manufacture of continuous analyte sensors are described in more detail elsewhere herein.

**[0237]** In this embodiment, the catheter includes a lumen 212a and an orifice 212b at its proximal end, for providing fluid connection from the catheter's lumen to the host's blood stream (see FIG. 2A).

**[0238]** In some embodiments, the catheter is inserted into a vein, as described elsewhere herein. In other embodiments, the catheter is inserted into an artery, as described elsewhere herein. The catheter can be any type of venous or arterial catheter commonly used in the art (e.g., peripheral catheter, central catheter, Swan-Gantz catheter, etc.). The catheter can be made of any useful medical grade material (e.g., polymers and/or glass) and can be of any size, such as but not limited to from about 1 French (0.33 mm) or less to about 30 French (10 mm) or more; for example, 2, 3, 4, 5, 6, 7, 8, 9, 10, 11, 12, 13, 14, 15, 16, 17, 18, 19, or 20 French (3 French is equivalent to about 1 mm). In certain embodiments, the catheter can be a single lumen catheter or a multi-lumen catheter. In some embodiments, the catheter can include one or more perforations, to allow the passage of host fluid through the lumen of the catheter.

**[0239]** At its distal end 212c, the catheter 212 includes (e.g., in fluid communication) a connector 218. The connector can be of any known type, such as a leuc lock, a T-connector, a Y-connector, a cross-connector or a custom configuration, for example. In some embodiments, the connector includes at least one valve. At a second side 218e (e.g., back end), the connector 218 can be operatively connected to a saline system (e.g., saline bag and tubing), other medical devices (e.g., automatic blood chemistry machine, dialysis machine, a blood bag for collecting donated blood, etc.), or capped.

**[0240]** In some embodiments, the system 210 includes sensor electronics (not shown) operatively connected to the analyte sensor, wherein the sensor electronics are generally configured to measure and/or process the sensor data as described in more detail elsewhere herein. In some embodiments, the sensor electronics can be partially or wholly disposed with (e.g., integral with, disposed on, or proximal to) the connector 218 at the distal end of the catheter or partially or wholly remote from the catheter (e.g., on a stand or on the bedside). In one embodiment, the sensor electronics disposed with the connector include a potentiostat. In some embodiments, the sensor electronics are configured to measure the host's ana-

lyte concentration substantially continuously. For example, the sensor can measure the analyte concentration continuously or at time intervals ranging from fractions of a second up to, for example, 1, 2, or 5 minutes or longer.

**[0241]** FIGS. 2C to 2F illustrate additional embodiments of the sensor shown in FIGS. 2A to 2B. The catheter 212 is shown with an integral sensor 214 having at least one electrode 240 formed on its exterior surface 232 (e.g., FIG. 2F). In general, the sensor can be designed with 1, 2, 3, 4 or more electrodes and can be connected by traces (or the like) to electrical contacts 218d (or the like) at the second end of the connector 218 (e.g., FIGS. 2A to 2F). In some embodiments, the sensor is hard-wired to the sensor electronics; alternatively, any operable connection can be used. Preferably, the sensor includes at least one working electrode and at least one reference or counter electrode. In some embodiments, the reference electrode is located proximal to the at least one working electrode (e.g., adjacent to or near to the working electrode). In some alternative embodiments, the reference electrode is located remotely from the working electrode (e.g., away from the working electrode, such as but not limited to within the lumen of the catheter 212 (or connector 218), on the exterior of the sensor system, in contact with the patient (e.g., on the skin), or the like). In some embodiments, the reference electrode is located proximal to or within the fluid connector, such as but not limited to coiled about the catheter adjacent to the fluid connector or coiled within the fluid connector and in contact with fluid flowing through the fluid coupler, such as saline or blood. In some embodiments, the sensor can also include one or more additional working electrodes (e.g., for measuring baseline, for measuring a second analyte, or for measuring a substantially non-analyte related signal, and the like, such as described in more detail in co-pending U.S. Publication No. US-2005-0143635-A1, and U.S. patent application Ser. No. 11/543,707 filed on Oct. 4, 2008, U.S. patent application Ser. No. 11/543,539 filed on Oct. 4, 2008, U.S. patent application Ser. No. 11/543,683 filed on Oct. 4, 2008, and U.S. patent application Ser. No. 11/543,734 filed on Oct. 4, 2008, each entitled "DUAL ELECTRODE SYSTEM FOR A CONTINUOUS ANALYTE SENSOR," which are incorporated herein by reference in their entirety. In some embodiments one or more counter electrodes can be provided on a surface of the catheter or within or on the fluid connector.

**[0242]** In some of the preferred embodiments, the catheter is designed to indwell within a host's blood flow (e.g., a peripheral vein or artery) and remain in the blood flow for a period of time (e.g., the catheter is not immediately removed). In some embodiments, the indwelling catheter can be inserted into the blood flow for example, for a few minutes or more, between about 1 and 24 hours, between about 1 and 10 days, or even longer. For example, the catheter can indwell in the host's blood stream during an entire perioperative period (e.g., from host admittance, through an operation, and to release from the hospital).

**[0243]** In some embodiments, the catheter is configured as an intravenous catheter (e.g., configured to be inserted into a vein). The catheter can be inserted into any commonly used vein, such as in a peripheral vein (e.g., one of the metacarpal veins of the arm); in some embodiments (e.g., such as described with reference to FIGS. 1A to 1E) the analyte sensor is inserted into a catheter. In alternative embodiments, the sensor is integrally formed on a catheter such as described in more detail with reference to FIGS. 2A to 2F, for example.

Other veins, such as leg or foot veins, hand veins, or even scalp or umbilical veins, can also be used.

**[0244]** In addition to sensing analyte levels via a sensor system as described herein, the intravenous catheter can be used for delivery of fluids and/or drugs to the host's circulatory system. The catheter can be configured to be coupled to other medical devices or functions, for example, saline, blood products, total parenteral feeding or medications can be given to the host via the indwelling intravenous catheter. In some embodiments, the catheter can be operatively connected to a pump, such as an infusion pump, to facilitate flow of the fluids into the host and a desired rate. For example, an infusion pump can pump saline into the host at a rate of 1 cc per minute, or at higher or lower rates. The rate of infusion can be changed (increased or decreased). For example, an infusion can be temporarily stopped, to permit injection of pain medication into the IV system, followed by increasing the infusion rate (e.g., for 5 minutes) to rapidly deliver the pain medication to the host's circulatory system.

**[0245]** In some embodiments, the catheter is configured as an arterial catheter (e.g., configured to be inserted into an arterial line or as part of an arterial line). Typically, an arterial catheter is inserted in the wrist (radial artery), armpit (axillary artery), groin (femoral artery), or foot (pedal artery). Generally, arterial catheters provide access to the host's blood stream (arterial side) for removal of blood samples and/or application of test devices, such as but not limited to a pressure transducer (for measuring blood pressure automatically), however, arterial catheters can also be used for delivery of fluids or medications. In one embodiment, a catheter is inserted into an arterial line and the sensor inserted into the catheter (e.g., functionally coupled) as described elsewhere herein. Saline filled non-compressible tubing is then coupled to the sensor, followed by a pressure transducer. An automatic flushing system (e.g., saline) is coupled to the tubing as well as a pressure bag to provide the necessary pressure. Electronics are generally operatively coupled to the pressure transducer for calculating and displaying a variety of parameters including blood pressure. Other medical devices can also be connected to the arterial catheter, to measure various blood components, such as but not limited to O<sub>2</sub>, CO<sub>2</sub>, PCO<sub>2</sub>, PO<sub>2</sub>, potassium, sodium, pH, lactate, urea, bilirubin, creatinine, hematocrit, various minerals, various metabolites, and the like.

**[0246]** In another embodiment, a blood pressure measurement system is inserted into the host and can be used as is known in the art. The analyte sensor (e.g., glucose sensor), such as the embodiment shown in FIGS. 1A-1E, is inserted into the pre-inserted (e.g., already in-dwelling) catheter using the following general methodology. First, the pressure transducer is temporarily disabled by disconnecting from the pre-inserted catheter. A cap (optionally) covers the protective slotted sheath and can be removed so as to enable the sensor to be grasped at the fluid coupler. The sheath, which is generally more rigid than the sensor but less flexible than a needle, is then threaded through the pre-inserted catheter so as to extend beyond the catheter into the blood stream (e.g., by about 0.001 inches to about 1 inches). The sheath is then removed by sliding the sensor through a small outlet hole and/or slot in the sheath. Thus, the sensor remains within the pre-inserted catheter and the fluid coupler, which supports the distal portion of the sensor, is coupled to the catheter itself. Saline filled non-compressible tubing is then coupled to the second side (e.g., back end) of the fluid coupler. The sensor

electronics (whether adjacent to the fluid coupler or otherwise wired to the fluid coupler) are then operatively connected (e.g., wired or wirelessly) to the sensor to initiate sensor function.

**[0247]** In some embodiments, a portion of the sensor system (e.g., sensor, catheter, or other component) can be configured to allow removal of blood samples from the host's blood stream (e.g., artery or vein). Sample removal can be done using any systems and methods known in the art, for example, as is practiced for removing a blood sample from an arterial catheter (e.g., and arterial line). In one such exemplary embodiment, any tubing or equipment coupled to the second side of the fluid coupler is disconnected. A syringe is then be coupled to the second side and blood removed via the catheter by pulling back on the syringe plunger. In a further embodiment, saline can be flushed through the fluid coupler and catheter. In another embodiment, the fluid coupler can be configured with a side valve, to allow coupling of a syringe, for removal of blood samples or delivery of fluids, such as medications, without disconnecting attached tubing of equipment, and the like. In still another embodiment, a valve or diaphragm, for access to the system by a syringe, can be coupled into the tubing at a short distance from the fluid coupler. In yet another embodiment, the sensor is integrally formed on the arterial catheter, such as the embodiment shown in FIGS. 2A-2B, and tubing can be disconnected from the connector, a syringe operably associated with the connector, and blood removed with the syringe. After blood collection, the syringe is removed and the tubing reconnected to the connector.

**[0248]** In still another embodiment, the analyte sensor can be functionally coupled to an extracorporeal blood flow device. A variety of devices exist for testing various blood properties/analytes at the bedside, such as but not limited to the blood gas and chemistry devices manufactured by Via Medical, Austin, Tex., USA. These devices generally withdraw a blood sample from the host, test the blood sample, and then return it to the host. Such a device can be connected in series to the arterial catheter, with the sensor in-between, and using systems and methods known in the art. In one embodiment, a sensor, such as the embodiment shown in FIGS. 1A-1E, is functionally connected to an in-dwelling arterial catheter, as described herein, and the extracorporeal blood flow device is connected to the second side of the fluid coupler. In an alternative embodiment, the sensor is integrally formed on the arterial catheter, such as the embodiment shown in FIGS. 2A-2F, and the extracorporeal blood flow device is functionally connected to the connector 218. Other devices, such as but not limited to dialysis machines, heart-lung bypass machines or blood collection bags, or other vascular access devices, can be functionally coupled to the analyte sensor.

**[0249]** The analyte sensor system of the preferred embodiments can be designed with a variety of alternative configurations. In some embodiments, the sensor is connected to a fluid connection device. The fluid connection device in these embodiments can be any standard fluid connection device known in the art, such as a fluid coupler, or a fluid coupler custom manufactured to preferred specifications. On its first side, the fluid coupler is configured to couple to an existing catheter or cannula (as described with reference to FIGS. 1A-1E). The catheter (or cannula) is typically inserted into a vascular access device and/or into a hospital host during a hospital stay. For example, the catheter can be inserted into an

arterial line (e.g., for removing blood samples or for measuring blood pressure using a pressure transducer) or a venous line (e.g., for intravenous delivery of drugs and other fluids). In general practice, the catheter is inserted into the host's blood vessel, for example, and maintained there for a period of time during the host's hospital stay, such as part of the stay or during the entire stay (e.g., perioperatively). In one alternative embodiment, another vascular access device (e.g., other than a catheter) can be used to receive the sensor. In yet another alternative embodiment, the sensor system of the preferred embodiments can be inserted into a vascular access device (e.g., rather than the vascular system directly). Some examples of vascular access devices include but are not limited to, catheters, shunts, automated blood withdrawal devices and the like.

**[0250]** In some embodiments, such as the embodiment illustrated in FIGS. 1A to 1E, the system 10 is configured such that the sensor is inserted into a vascular access device, such as but not limited to a catheter 12 (e.g., a catheter that has been inserted into the host's blood stream prior to sensor insertion). In general, catheters are small, flexible tubes (e.g., soft catheter) but they can also be larger, rigid tubes. Catheters are inserted into a host's body cavity, vessel, or duct to provide access for fluid removal or insertion, or for access to medical equipment. Catheters can also be inserted into extracorporeal devices, such as but not limited to an arterio-venous shunt for the transfer of blood from an artery to a vein. Some catheters are used to direct access to the circulatory system (e.g., venous or arterial catheters, Swan Gantz catheters) to allow removal of blood samples, the infusion of fluids (e.g., saline, medications, blood or total parenteral feeding) or access by medical devices (e.g., stents, extracorporeal blood chemistry analysis devices, invasive blood pressure monitors, etc.).

**[0251]** Preferably, the sensor is designed to include a protective cap, as illustrated in FIGS. 1A-1E. Namely, FIGS. 1A and 1B illustrates the catheter (the catheter cap having been removed prior to insertion), well known to those skilled in the art, which can be inserted into the host's blood vessel using standard methods. The sensor 14 is configured for measurement of an analyte (e.g., glucose) in the host's body, and is in fluid connection within the catheter lumen, which is in fluid connection with the fluid coupler 20 of the sensor. The first side 20a of the fluid coupler 20 of the sensor is designed to couple to the catheter, e.g., by screwing or snapping thereon, and can also couple (on its second side 20b) with other medical devices. One advantage of the fluid coupler is that it provides for a small amount of bleed back, to prevent air bubbles in the host's blood stream.

**[0252]** The exemplary sensor system 10 of FIGS. 1A and 1B further includes a slotted protective sheath 26 that supports and protects the sensor during sensor insertion, for example, the sheath increases the sensor visibility (e.g., the sensor is so thin that it can be difficult for some people to see without the protective sheath) and provides for ease of sliding the sensor into the catheter. The slotted protective sheath is configured to fit within the fluid coupler and houses the sensor during insertion of the sensor into the catheter (e.g., an indwelling catheter within the host's blood flow). Preferably, the protective sheath is substantially more rigid than the sensor and at the same time substantially more flexible than a standard syringe needle, however other designs are possible. To facilitate removal of the protective sheath, a slot 30 is provided with an optional outlet hole 30a, which is described in more detail with reference to FIG. 1C, and a hub 28. By

grasping and pulling the hub, the user (e.g., health care professional) can withdraw the protective sheath after coupling the fluid coupler to the catheter. Prior to insertion of the sensor, a cap is provided, to cover the protective sheath, for example, to keep the sheath and sensor sterile, and to prevent damage to the components during shipping and/or handling.

**[0253]** In general, the sensor system is configured with a potentiostat and/or sensor electronics that are operatively coupled to the sensor. In some embodiments, a portion of the sensor electronics, such as the potentiostat, can be disposed directly on the fluid coupler. However, some or all of the sensor electronics (including the potentiostat) can be disposed remotely from the fluid coupler (e.g., on the bedside or on a stand) and can be functionally coupled (e.g., wired or wireless), as is generally known to those skilled in the art.

**[0254]** FIGS. 1C1 and 1C2 are cross-sectional views (not to scale) of the fluid coupler, including a protective sheath 26, a sensor 14, and a cap 32 (cap to be removed prior to insertion) in one embodiment. The protective sheath 26 extends through the fluid coupler and houses the sensor, for sensor insertion into a catheter. The protective sheath includes an optional outlet hole 30a, through which the sensor extends and a slot 30 along a length of the protective sheath that communicates with the outlet hole and enables the protective sheath to be removed after the sensor has been inserted into the host's body. The protective sheath includes a hub 28 for ease of handling.

**[0255]** In some embodiments, the glucose sensor is utilized in combination with another medical device (e.g., a medical device or access port that is already coupled to, applied to, or connected to the host) in a hospital or similar clinical setting. For example, a catheter can be inserted into the host's vein or artery, wherein the catheter can be connected to additional medical equipment. In an alternative example, the catheter is placed in the host to provide quick access to the host's circulatory system (in the event of a need arising) and is simply capped. In another example, a dialysis machine can be connected to the host's circulatory system. In another example, a central line can be connected to the host, for insertion of medical equipment at the heart (e.g., the medical equipment reaches the heart through the vascular system, from a peripheral location such as a leg or arm pit).

**[0256]** In practice of coupling to a catheter, before insertion of the sensor, the access port is opened. In one exemplary embodiment of a pre-inserted catheter that is capped, the cap is removed and the sensor inserted into the catheter. The back end of the sensor system can be capped or attached to additional medical equipment (e.g., saline drip, blood pressure transducer, dialysis machine, blood chemistry analysis device, etc.). In another exemplary embodiment, medical equipment (e.g., saline drip, blood pressure transducer, dialysis machine, blood chemistry analysis device, etc.) is already connected to the catheter. The medical equipment is disconnected from the catheter, the sensor inserted into (and coupled to) the catheter and then the medical equipment reconnected (e.g., coupled to the back end of the sensor system).

**[0257]** In some embodiments, the sensor is inserted directly into the host's circulatory system without a catheter or other medical device. In one such exemplary embodiment, the sheath covering the sensor is relatively rigid and supports the sensor during insertion. After the sensor has been inserted into the host's vein or artery, the supportive sheath is removed, leaving the exposed sensor in the host's vein or artery. In an alternative example, the sensor is inserted into a

vascular access device (e.g., with or without a catheter) and the sheath removed, to leave the sensor in the host's vein or artery (e.g., through the vascular access device).

**[0258]** In various embodiments, in practice, prior to insertion, the cap **32** over the protective sheath is removed as the health care professional holds the glucose sensor by the fluid coupler **20**. The protective sheath **26**, which is generally more rigid than the sensor but more flexible than a needle, is then threaded through the catheter so as to extend beyond the catheter into the blood flow (e.g., by about 0.010 inches to about 1 inches). The protective sheath is then removed by sliding the sensor through the (optional) outlet hole **30a** and slotted portion **30** of the sheath (e.g., by withdrawing the protective sheath by pulling the hub **28**). Thus the sensor remains within the catheter; and the fluid coupler **20**, which holds the sensor **14**, is coupled to the catheter itself (via its connector **18**). Other medical devices can be coupled to the second side of the fluid coupler as desired. The sensor electronics (e.g., adjacent to the fluid coupler or otherwise coupled to the fluid coupler) are then operatively connected (e.g., wired or wirelessly) to the sensor for proper sensor function as is known in the art.

**[0259]** In another embodiment, the catheter **12** includes a plurality of perforations (e.g., holes) that allow the host's fluid (e.g., blood) to flow through the lumen **12a** of the catheter. The fluid flowing through the catheter can make contact with a sensor **14** inserted therein. In a further embodiment, the sensor does not protrude out of the catheter's tip **12b** and the host's blood flowing through the perforated catheter's lumen contacts the sensor's electroactive surfaces.

**[0260]** In still another embodiment, the catheter **12** includes at least a first lumen and a second lumen. The sensor **14** is configured for insertion into the catheter's first lumen. The second lumen can be used for infusions into the host's circulatory system or sample removal without disturbing the sensor within the first lumen.

**[0261]** FIGS. 2A-2F are schematic views of a sensor integrally formed (integrally incorporated) onto a surface of a catheter, in some exemplary embodiments. In some embodiments, the sensor can be integrally formed on an exterior surface **232** of the catheter. In other embodiments, the sensor can be integrally formed on an interior surface of the catheter (e.g., on a luminal surface). In still other embodiments, the sensor can be integrally formed on the sensor's tip (e.g., as indicated by **214a**). In yet other embodiments, the sensor can be integrally incorporated with the catheter, for example by bonding a sensor of the type described in FIGS. 3A to 3C into an inner or outer surface of the catheter.

**[0262]** Generally, the sensor system is provided with a cap that covers the catheter and in vivo portion of the integral sensor. A needle or trochar that runs the length of the catheter supports the device during insertion into the host's blood stream. Prior to use, medical caregiver holds the device by the fluid connector **218** and removes the cap to expose the in vivo portion of the device (e.g., the catheter). The caregiver inserts the in vivo portion of the device into one of the host's veins or arteries (depending upon whether the catheter is an intravenous catheter or an arterial catheter). After insertion, the needle is withdrawn from the device. The device is then capped or connected to other medical equipment (e.g., saline bag, pressure transducer, blood collection bag, total parenteral feeding, dialysis equipment, automated blood chemistry equipment, etc.). In some alternative embodiments, the sensor-integrated catheter can be in communica-

tion (e.g., fluid communication) with the host's vascular system through a vascular access device.

**[0263]** In some embodiments, a glucose sensor system includes a sensing mechanism substantially similar to that described in U.S. Publication 2006-0020187, which is incorporated herein by reference in its entirety; for example, with platinum working electrode and silver reference electrode coiled there around. Alternatively, the reference electrode can be located remote from the working electrode so as not to be inserted into the host, and can be located, for example, within the fluid coupler, thereby allowing a smaller footprint in the portion of the sensor adapted for insertion into the body (e.g., blood stream); for example, without a coiled or otherwise configured reference electrode proximal to the working electrode. Although a platinum working electrode is discussed, a variety of known working electrode materials can be utilized (e.g., Platinum-Iridium or Iridium). When located remotely, the reference electrode can be located away from the working electrode (e.g., the electroactive portion) at any location and with any configuration so as to maintain bodily and/or in fluid communication therewith as is appreciated by one skilled in the art.

**[0264]** In an alternative embodiment, the sensor tip **14a** includes an enlarged, atraumatic area, for example a dull or bulbous portion about two times the diameter of the sensor or larger. In one exemplary embodiment, the enlarged portion is created by heating, welding, crushing or bonding a substantially rounded structure onto the tip of the sensor (e.g., polymer or metal). In another exemplary embodiment, the tip of the sensor is heated (e.g., arc welded or flash-butt resistance welded) to cause the tip to enlarge (e.g., by melting). The enlarged portion can be of any atraumatic shape, such as but not limited to oval, round, cone-shaped, cylindrical, teardrop, etc. While not wishing to be bound by theory, it is believed that an atraumatic or enlarged area enables enhanced stability of a small diameter sensor in the blood flow and ensures that the sensor remains within the blood flow (e.g., to avoid piercing a vessel wall and/or becoming inserted subclinically.)

**[0265]** In some embodiments, a second working electrode can be provided on the sensor for measuring baseline, and thereby subtracting the baseline from the first working electrode to obtain a glucose-only signal, as disclosed in copending U.S. Publication No. US-2005-0143635-A1, and U.S. patent application Ser. No. 11/543,707 filed on Oct. 4, 2008, U.S. patent application Ser. No. 11/543,539 filed on Oct. 4, 2008, U.S. patent application Ser. No. 11/543,683 filed on Oct. 4, 2008, and U.S. patent application Ser. No. 11/543,734 filed on Oct. 4, 2008, each entitled "DUAL ELECTRODE SYSTEM FOR A CONTINUOUS ANALYTE SENSOR," herein incorporated by reference in its entirety.

**[0266]** Referring now to FIGS. 2A-2E in more detail, some embodiments of the analyte sensor system include a catheter **212** adapted for inserting into a host in a hospital or clinical setting, wherein the analyte sensor **214** is built integrally with the catheter **212**. For example, a glucose sensor can be integrally formed on the catheter itself. FIGS. 2A-2B illustrate one embodiment, wherein the catheter **212** is configured both for insertion into a host, and can be configured to couple to other medical devices on its ex vivo end. However, coupling to other medical devices is not necessary. In some embodiments, the catheter includes a connector **218** configured for connection to tubing or other medical devices, as described herein. The embodiment shown in FIGS. 2A-2B includes two or three electrodes **240** on the outer surface of the in vivo

portion of the catheter **212**. In some embodiments, the catheter is perforated (as described elsewhere herein) and at least one electrode is disposed within the lumen (not shown) of the perforated catheter. In some embodiments, the catheter includes a single lumen. In other embodiment, the catheter includes two or more lumens.

[0267] With reference to FIGS. 2C-2E, in some embodiments, at least one working electrode **240** is disposed on the exterior surface of the in vivo portion of the catheter. Alternatively, the at least one working electrode can be disposed on an interior surface of the catheter, the tip of the catheter, extend from the catheter, and the like. In general, the preferred embodiments can be designed with any number of electrodes, including one or more counter electrodes, one or more reference electrodes, and/or one or more auxiliary working electrodes. In further embodiments, the electrodes can be of relatively larger or smaller surface area, depending upon their uses. In one example, a sensor includes a working electrode and a reference electrode that has a larger surface area (relative to the surface area of the working electrode) on the surface of the catheter. In another example, a sensor includes a working electrode, a counter electrode, and a reference electrode sized to have an increased surface area as compared to the working and/or counter electrode. In some embodiments, the reference electrode is disposed at a location remote from the working electrode, such as within the connector (e.g., coiled within the connector). In some embodiments, the reference electrode is located on the host's body (e.g., in body contact).

[0268] The electrodes **240** can be deposited on the catheter using any suitable techniques known in the art, for example, thick or thin film deposition techniques. The electrodes can be formed of any advantageous electrode materials known in the art (e.g., platinum, platinum-iridium, palladium, graphite, gold, carbon, silver, silver-silver chloride, conductive polymer, alloys, combinations thereof, and the like). In other embodiments, one or more of the electrodes is formed from an electrically conductive material (e.g., wire or foil comprising platinum, platinum-iridium, palladium, graphite, gold, carbon, silver, silver-silver chloride, conductive polymer, alloys, combinations thereof, and the like) applied to the exterior surface of the catheter, such as but not limited to twisting, coiling, rolling or adhering.

[0269] In some embodiments, the catheter is (wired or wirelessly) connected to sensor electronics (not shown, disposed on the catheter's connector and/or remote from the catheter) so as to electrically connect the electrodes on the catheter with the sensor electronics. The inserted catheter (including the sensor integrally formed thereon) can be utilized by other medical devices for a variety of functions (e.g., blood pressure monitor, drug delivery, etc).

[0270] While not wishing to be bound by theory, a number of the systems and methods disclosed in the preferred embodiments (e.g., an analyte sensor to be disposed in communication with the host's blood), can be employed in transcutaneous (e.g., transdermal) or wholly implantable analyte sensor devices. For example, the sensor could be integrally formed on the in vivo portion of a subcutaneous device or a wholly implantable device. As another example, an enlarged surface area (e.g., bulbous end) can be useful in the design of a transcutaneous analyte sensor.

#### Exemplary Sensor Configurations

[0271] Referring to FIGS. 3A to 3C, in some embodiments, the sensor can be configured similarly to the continuous analyte sensors disclosed in co-pending U.S. patent application Ser. No. 11/360,250 filed Feb. 22, 2006 and entitled "ANALYTE SENSOR," herein incorporated by reference in its entirety. The sensor includes a distal portion **342**, also referred to as the in vivo portion, adapted for insertion into the catheter as described above, and a proximal portion **340**, also referred to as an ex vivo portion, adapted to operably connect to the sensor electronics. Preferably, the sensor includes two or more electrodes: a working electrode **344** and at least one additional electrode, which can function as a counter electrode and/or reference electrode, hereinafter referred to as the reference electrode **346**. A membrane system is preferably deposited over the electrodes, such as described in more detail with reference to FIGS. 3A to 3C, below.

[0272] FIG. 3B is an expanded cutaway view of a distal portion of the sensor in one embodiment, showing working and reference electrodes. In preferred embodiments, the sensor is formed from a working electrode **344** (e.g., a wire) and a reference electrode **346** helically wound around the working electrode **344**. An insulator **345** is disposed between the working and reference electrodes to provide electrical insulation therebetween. Certain portions of the electrodes are exposed to enable electrochemical reaction thereon, for example, a window **343** can be formed in the insulator to expose a portion of the working electrode **344** for electrochemical reaction.

[0273] In preferred embodiments, each electrode is formed from a fine wire with a diameter of from about 0.001 inches or less to about 0.010 inches or more, for example, and is formed from, e.g., a plated insulator, a plated wire, or bulk electrically conductive material. Although the illustrated electrode configuration and associated text describe one preferred method of forming a sensor, a variety of known sensor configurations can be employed with the analyte sensor system of the preferred embodiments, such as U.S. Pat. No. 5,711,861 to Ward et al., U.S. Pat. No. 6,642,015 to Vachon et al., U.S. Pat. No. 6,654,625 to Say et al., U.S. Pat. No. 6,565,509 to Say et al., U.S. Pat. No. 6,514,718 to Heller, U.S. Pat. No. 6,465,066 to Essenpreis et al., U.S. Pat. No. 6,214,185 to Offenbacher et al., U.S. Pat. No. 5,310,469 to Cunningham et al., and U.S. Pat. No. 5,683,562 to Shaffer et al., U.S. Pat. No. 6,579,690 to Bonnez et al., U.S. Pat. No. 6,484,046 to Say et al., U.S. Pat. No. 6,512,939 to Colvin et al., U.S. Pat. No. 6,424,847 to Mastrototaro et al., U.S. Pat. No. 6,424,847 to Mastrototaro et al., for example. All of the above patents are incorporated in their entirety herein by reference and are not inclusive of all applicable analyte sensors; in general, it should be understood that the disclosed embodiments are applicable to a variety of analyte sensor configurations. It is noted that much of the description of the preferred embodiments, for example the membrane system described below, can be implemented not only with in vivo sensors, but also with in vitro sensors, such as blood glucose meters (SMBG).

[0274] In some embodiments, the working electrode comprises a wire formed from a conductive material, such as platinum, platinum-iridium, palladium, graphite, gold, carbon, conductive polymer, alloys, and the like. Although the electrodes can be formed by a variety of manufacturing techniques (bulk metal processing, deposition of metal onto a substrate, and the like), it can be advantageous to form the electrodes from plated wire (e.g., platinum on steel wire) or

bulk metal (e.g., platinum wire). It is believed that electrodes formed from bulk metal wire provide superior performance (e.g., in contrast to deposited electrodes), including increased stability of assay, simplified manufacturability, resistance to contamination (e.g., which can be introduced in deposition processes), and improved surface reaction (e.g., due to purity of material) without peeling or delamination.

[0275] In some embodiments, the working electrode is formed of platinum-iridium or iridium wire. In general, platinum-iridium and iridium materials are generally stronger (e.g., more resilient and less likely to fail due to stress or strain fracture or fatigue). It is believed that platinum-iridium and/or iridium materials can facilitate a wire with a smaller diameter to further decrease the maximum diameter (size) of the sensor (e.g., in vivo portion). Advantageously, a smaller sensor diameter both reduces the risk of clot or thrombus formation (or other foreign body response) and allows the use of smaller catheters.

[0276] The electroactive window 343 of the working electrode 344 is configured to measure the concentration of an analyte. In an enzymatic electrochemical sensor for detecting glucose, for example, the working electrode measures the hydrogen peroxide produced by an enzyme catalyzed reaction of the analyte being detected and creates a measurable electronic current. For example, in the detection of glucose wherein glucose oxidase produces hydrogen peroxide as a byproduct, hydrogen peroxide reacts with the surface of the working electrode producing two protons ( $2H^+$ ), two electrons ( $2e^-$ ) and one molecule of oxygen ( $O_2$ ), which produces the electronic current being detected.

[0277] In preferred embodiments, the working electrode 344 is covered with an insulating material 345, for example, a non-conductive polymer. Dip-coating, spray-coating, vapor-deposition, or other coating or deposition techniques can be used to deposit the insulating material on the working electrode. In one embodiment, the insulating material comprises parylene, which can be an advantageous polymer coating for its strength, lubricity, and electrical insulation properties. Generally, parylene is produced by vapor deposition and polymerization of para-xylylene (or its substituted derivatives). While not wishing to be bound by theory, it is believed that the lubricious (e.g., smooth) coating (e.g., parylene) on the sensors of some embodiments contributes to minimal trauma and extended sensor life. While parylene coatings are generally preferred in some embodiments, any suitable insulating material can be used, for example, fluorinated polymers, polyethyleneterephthalate, polyurethane, polyimide, other nonconducting polymers, and the like. Glass or ceramic materials can also be employed. Other materials suitable for use include surface energy modified coating systems such as are marketed under the trade names AMC18, AMC148, AMC141, and AMC321 by Advanced Materials Components Express of Bellafonte, Pa. In some alternative embodiments, however, the working electrode may not require a coating of insulator.

[0278] The reference electrode 346, which can function as a reference electrode alone, or as a dual reference and counter electrode, is formed from silver, silver/silver chloride, and the like. In some embodiments, the reference electrode 346 is juxtapositioned and/or twisted with or around the working electrode 344; however other configurations are also possible (e.g., coiled within the fluid connector, or an intradermal or on-skin reference electrode). In the illustrated embodiments, the reference electrode 346 is helically wound around the

working electrode 344. The assembly of wires is then optionally coated or adhered together with an insulating material, similar to that described above, so as to provide an insulating attachment.

[0279] In some embodiments, a silver wire is formed onto the sensor as described above, and subsequently chloridized to form silver/silver chloride reference electrode. Advantageously, chloridizing the silver wire as described herein enables the manufacture of a reference electrode with optimal in vivo performance. Namely, by controlling the quantity and amount of chloridization of the silver to form silver/silver chloride, improved break-in time, stability of the reference electrode, and extended life has been shown with some embodiments. Additionally, use of silver chloride as described above allows for relatively inexpensive and simple manufacture of the reference electrode.

[0280] In embodiments wherein an outer insulator is disposed, a portion of the coated assembly structure can be stripped or otherwise removed, for example, by hand, excimer lasing, chemical etching, laser ablation, grit-blasting (e.g., with sodium bicarbonate or other suitable grit), and the like, to expose the electroactive surfaces. Alternatively, a portion of the electrode can be masked prior to depositing the insulator in order to maintain an exposed electroactive surface area. In one exemplary embodiment, grit blasting is implemented to expose the electroactive surfaces, preferably utilizing a grit material that is sufficiently hard to ablate the polymer material, while being sufficiently soft so as to minimize or avoid damage to the underlying metal electrode (e.g., a platinum electrode). Although a variety of "grit" materials can be used (e.g., sand, talc, walnut shell, ground plastic, sea salt, and the like), in some preferred embodiments, sodium bicarbonate is an advantageous grit-material because it is sufficiently hard to ablate, e.g., a parylene coating, without damaging, e.g., an underlying platinum conductor. One additional advantage of sodium bicarbonate blasting includes its polishing action on the metal as it strips the polymer layer, thereby eliminating a cleaning step that might otherwise be necessary.

[0281] In the embodiment illustrated in FIG. 3B, a radial window 343 is formed through the insulating material 345 to expose a circumferential electroactive surface of the working electrode. Additionally, sections of electroactive surface of the reference electrode are exposed. For example, the sections of electroactive surface can be masked during deposition of an outer insulating layer or etched after deposition of an outer insulating layer.

[0282] In some applications, cellular attack or migration of cells to the sensor can cause reduced sensitivity and/or function of the device, particularly after the first day of implantation. However, when the exposed electroactive surface is distributed circumferentially about the sensor (e.g., as in a radial window), the available surface area for reaction can be sufficiently distributed so as to minimize the effect of local cellular invasion of the sensor on the sensor signal. Alternatively, a tangential exposed electroactive window can be formed, for example, by stripping only one side of the coated assembly structure. In other alternative embodiments, the window can be provided at the tip of the coated assembly structure such that the electroactive surfaces are exposed at the tip of the sensor. Other methods and configurations for exposing electroactive surfaces can also be employed.

[0283] In some embodiments, the working electrode has a diameter of from about 0.001 inches or less to about 0.010

inches or more, preferably from about 0.002 inches to about 0.008 inches, and more preferably from about 0.004 inches to about 0.005 inches. The length of the window can be from about 0.1 mm (about 0.004 inches) or less to about 2 mm (about 0.078 inches) or more, and preferably from about 0.25 mm (about 0.01 inches) to about 0.375 mm (about 0.015 inches). In such embodiments, the exposed surface area of the working electrode is preferably from about 0.000013 in<sup>2</sup> (0.0000839 cm<sup>2</sup>) or less to about 0.0025 in<sup>2</sup> (0.016129 cm<sup>2</sup>) or more (assuming a diameter of from about 0.001 inches to about 0.010 inches and a length of from about 0.004 inches to about 0.078 inches). The preferred exposed surface area of the working electrode is selected to produce an analyte signal with a current in the picoAmp range, such as is described in more detail elsewhere herein. However, a current in the picoAmp range can be dependent upon a variety of factors, for example the electronic circuitry design (e.g., sample rate, current draw, A/D converter bit resolution, etc.), the membrane system (e.g., permeability of the analyte through the membrane system), and the exposed surface area of the working electrode. Accordingly, the exposed electroactive working electrode surface area can be selected to have a value greater than or less than the above-described ranges taking into consideration alterations in the membrane system and/or electronic circuitry. In preferred embodiments of a glucose sensor, it can be advantageous to minimize the surface area of the working electrode while maximizing the diffusivity of glucose in order to optimize the signal-to-noise ratio while maintaining sensor performance in both high and low glucose concentration ranges.

**[0284]** In some alternative embodiments, the exposed surface area of the working (and/or other) electrode can be increased by altering the cross-section of the electrode itself. For example, in some embodiments the cross-section of the working electrode can be defined by a cross, star, cloverleaf, ribbed, dimpled, ridged, irregular, or other non-circular configuration; thus, for any predetermined length of electrode, a specific increased surface area can be achieved (as compared to the area achieved by a circular cross-section). Increasing the surface area of the working electrode can be advantageous in providing an increased signal responsive to the analyte concentration, which in turn can be helpful in improving the signal-to-noise ratio, for example.

**[0285]** In some alternative embodiments, additional electrodes can be included within the assembly, for example, a three-electrode system (working, reference, and counter electrodes) and/or an additional working electrode (e.g., an electrode which can be used to generate oxygen, which is configured as a baseline subtracting electrode, or which is configured for measuring additional analytes). U.S. Publication No. US-2005-0161346-A1, U.S. Publication No. US-2005-0143635-A1, and U.S. patent application Ser. No. 11/543,707 filed on Oct. 4, 2008, U.S. patent application Ser. No. 11/543,539 filed on Oct. 4, 2008, U.S. patent application Ser. No. 11/543,683 filed on Oct. 4, 2008, and U.S. patent application Ser. No. 11/543,734 filed on Oct. 4, 2008, each entitled "DUAL ELECTRODE SYSTEM FOR A CONTINUOUS ANALYTE SENSOR," describe some systems and methods for implementing and using additional working, counter, and/or reference electrodes. In one implementation wherein the sensor comprises two working electrodes, the two working electrodes are juxtapositioned (e.g., extend parallel to each other), around which the reference electrode is disposed (e.g., helically wound). In some embodiments

wherein two or more working electrodes are provided, the working electrodes can be formed in a double-, triple-, quad-, etc. helix configuration along the length of the sensor (for example, surrounding a reference electrode, insulated rod, or other support structure). The resulting electrode system can be configured with an appropriate membrane system, wherein the first working electrode is configured to measure a first signal comprising glucose and baseline (e.g., background noise) and the additional working electrode is configured to measure a baseline signal consisting of baseline only (e.g., configured to be substantially similar to the first working electrode without an enzyme disposed thereon). In this way, the baseline signal can be subtracted from the first signal to produce a glucose-only signal that is substantially not subject to fluctuations in the baseline and/or interfering species on the signal.

**[0286]** Although the embodiments of FIGS. 3A to 3C illustrate one electrode configuration including one bulk metal wire helically wound around another bulk metal wire, other electrode configurations are also contemplated. In an alternative embodiment, the working electrode comprises a tube with a reference electrode disposed or coiled inside, including an insulator therebetween. Alternatively, the reference electrode comprises a tube with a working electrode disposed or coiled inside, including an insulator therebetween. In another alternative embodiment, a polymer (e.g., insulating) rod is provided, wherein the electrodes are deposited (e.g., electroplated) thereon. In yet another alternative embodiment, a metallic (e.g., steel) rod is provided, coated with an insulating material, onto which the working and reference electrodes are deposited. In yet another alternative embodiment, one or more working electrodes are helically wound around a reference electrode.

**[0287]** Preferably, the electrodes and membrane systems of the preferred embodiments are coaxially formed, namely, the electrodes and/or membrane system all share the same central axis. While not wishing to be bound by theory, it is believed that a coaxial design of the sensor enables a symmetrical design without a preferred bend radius. Namely, in contrast to prior art sensors comprising a substantially planar configuration that can suffer from regular bending about the plane of the sensor, the coaxial design of the preferred embodiments do not have a preferred bend radius and therefore are not subject to regular bending about a particular plane (which can cause fatigue failures and the like). However, non-coaxial sensors can be implemented with the sensor system of the preferred embodiments.

**[0288]** In addition to the above-described advantages, the coaxial sensor design of the preferred embodiments enables the diameter of the connecting end of the sensor (proximal portion) to be substantially the same as that of the sensing end (distal portion) such that the protective slotted sheath is able to insert the sensor into the catheter and subsequently slide back over the sensor and release the sensor from the protective slotted sheath, without complex multi-component designs.

**[0289]** In one such alternative embodiment, the two wires of the sensor are held apart and configured for insertion into the catheter in proximal but separate locations. The separation of the working and reference electrodes in such an embodiment can provide additional electrochemical stability with simplified manufacture and electrical connectivity. One

skilled in the art will appreciate that a variety of electrode configurations can be implemented with the preferred embodiments.

**[0290]** In addition to the above-described configurations, the reference electrode can be separated from the working electrode, and coiled within a portion of the fluid connector, in some embodiments. In another embodiment, the reference electrode is coiled within the fluid connector and adjacent to its first side. In an alternative embodiment, the reference electrode is coiled within the fluid connector and adjacent to its second side. In such embodiments, the reference electrode is in contact with fluid, such as saline from a saline drip that is flowing into the host, or such as blood that is being withdrawn from the host. While not wishing to be bound by theory, this configuration is believed to be advantageous because the sensor is thinner, allowing the use of smaller catheters and/or a reduced likelihood to thrombus production.

**[0291]** In another embodiment, the reference electrode **346** can be disposed farther away from the electroactive portion of the working electrode **343** (e.g., closer to the fluid connector). In some embodiments, the reference electrode is located proximal to or within the fluid coupler, such as but not limited to coiled about the catheter adjacent to the fluid coupler or coiled within the fluid coupler and in contact with fluid flowing through the fluid coupler, such as saline. These configurations can also minimize at least a portion of the sensor diameter and thereby allow the use of smaller catheters and reduce the risk of clots.

**[0292]** In addition to the embodiments described above, the sensor can be configured with additional working electrodes as described in U.S. Publication No. US-2005-0143635-A1, U.S. Pat. No. 7,081,195, and U.S. patent application Ser. No. 11/543,707 filed on Oct. 4, 2008, U.S. patent application Ser. No. 11/543,539 filed on Oct. 4, 2008, U.S. patent application Ser. No. 11/543,683 filed on Oct. 4, 2008, and U.S. patent application Ser. No. 11/543,734 filed on Oct. 4, 2008, each entitled "DUAL ELECTRODE SYSTEM FOR A CONTINUOUS ANALYTE SENSOR," herein incorporated by reference in their entirety. For example, in one embodiment have an auxiliary working electrode, wherein the auxiliary working electrode comprises a wire formed from a conductive material, such as described with reference to the glucose-measuring working electrode above. Preferably, the reference electrode, which can function as a reference electrode alone, or as a dual reference and counter electrode, is formed from silver, Silver/Silver chloride, and the like.

**[0293]** In some embodiments, the electrodes are juxtapositioned and/or twisted with or around each other; however other configurations are also possible. In one example, the auxiliary working electrode and reference electrode can be helically wound around the glucose-measuring working electrode. Alternatively, the auxiliary working electrode and reference electrode can be formed as a double helix around a length of the glucose-measuring working electrode. The assembly of wires can then be optionally coated together with an insulating material, similar to that described above, in order to provide an insulating attachment. Some portion of the coated assembly structure is then stripped, for example using an excimer laser, chemical etching, and the like, to expose the necessary electroactive surfaces. In some alternative embodiments, additional electrodes can be included within the assembly, for example, a three-electrode system (including separate reference and counter electrodes) as is appreciated by one skilled in the art.

**[0294]** In some alternative embodiments, the sensor is configured as a dual-electrode system. In one such dual-electrode system, a first electrode functions as a hydrogen peroxide sensor including a membrane system containing glucose-oxidase disposed thereon, which operates as described herein. A second electrode is a hydrogen peroxide sensor that is configured similar to the first electrode, but with a modified membrane system (without active enzyme, for example). This second electrode provides a signal composed mostly of the baseline signal, b.

**[0295]** In some dual-electrode systems, the baseline signal is (electronically or digitally) subtracted from the glucose signal to obtain a glucose signal substantially without baseline. Accordingly, calibration of the resultant difference signal can be performed by solving the equation  $y=mx$  with a single paired measurement. Calibration of the inserted sensor in this alternative embodiment can be made less dependent on the values/range of the paired measurements, less sensitive to error in manual blood glucose measurements, and can facilitate the sensor's use as a primary source of glucose information for the user. U.S. Publication No. US-2005-0143635-A1 describes systems and methods for subtracting the baseline from a sensor signal.

**[0296]** In some alternative dual-electrode system embodiments, the analyte sensor is configured to transmit signals obtained from each electrode separately (e.g., without subtraction of the baseline signal). In this way, the receiver can process these signals to determine additional information about the sensor and/or analyte concentration. For example, by comparing the signals from the first and second electrodes, changes in baseline and/or sensitivity can be detected and/or measured and used to update calibration (e.g., without the use of a reference analyte value). In one such example, by monitoring the corresponding first and second signals over time, an amount of signal contributed by baseline can be measured. In another such example, by comparing fluctuations in the correlating signals over time, changes in sensitivity can be detected and/or measured.

**[0297]** In some embodiments, the reference electrode can be disposed remotely from the working electrode. In one embodiment, the reference electrode remains within the fluid flow, but is disposed within the fluid coupler. For example, the reference electrode can be coiled within the fluid coupler such that it is contact with saline flowing into the host, but it is not in physical contact with the host's blood (except when blood is withdrawn from the catheter). In another embodiment, the reference electrode is removed from fluid flow, but still maintains bodily fluid contact. For example, the reference electrode can be wired to an adhesive patch that is adhered to the host, such that the reference electrode is in contact with the host's skin. In yet another embodiment, the reference electrode can be external from the system, such as but not limited to in contact with the exterior of the ex vivo portion of the system, in fluid or electrical contact with a connected saline drip or other medical device, or in bodily contact, such as is generally done with EKG electrical contacts. While not wishing to be bound by theory, it is believed to locating the reference electrode remotely from the working electrode permits manufacture of a smaller sensor footprint (e.g., diameter) that will have relatively less affect on the host's blood flow, such as less thrombosis, than a sensor having a relatively larger footprint (e.g., wherein both the working electrode and the reference electrode are adjacent to each other and within the blood path).



**[0298]** In some embodiments of the sensor system, in vivo portion of the sensor (e.g., the tip **14a**) has an enlarged area (e.g., a bulbous, nail head-shaped, football-shaped, cone-shaped, cylindrical, etc. portion) as compared a substantial portion of the sensor (e.g., diameter of the in vivo portion of the sensor). The sensor tip can be made bulbous by any convenient systems and methods known in the art, such as but not limited to arc welding, crimping, smashing, welding, molding, heating, and plasma arc welding. While not wishing to be bound by theory, it is believed that an enlarged sensor tip (e.g., bulbous) will prevent vessel piercing as the sensor is pushed forward into the vessel.

**[0299]** The sensor of the preferred embodiments is designed with a minimally invasive architecture so as to minimize reactions or effects on the blood flow (or on the sensor in the blood flow). Accordingly, the sensor designs described herein, consider minimization of dimensions and arrangement of the electrodes and other components of the sensor system, particularly the in vivo portion of the sensor (or any portion of the sensor in fluid contact with the blood flow).

**[0300]** Accordingly, in some embodiments, a substantial portion of the in vivo portion of the sensor is designed with at least one dimension less than about 0.015, 0.012, 0.010, 0.008, 0.006, 0.005, 0.004 inches. In some embodiments, a substantial portion of the sensor that is in fluid contact with the blood flow is designed with at least one dimension less than about 0.015, 0.012, 0.010, 0.008, 0.006, 0.005, 0.004, 0.003, 0.002, 0.001 inches. As one exemplary embodiment, a sensor such as described in more detail with reference to FIGS. **1A** to **1C** is formed from a 0.004-inch conductive wire (e.g., platinum) for a diameter of about 0.004 inches along a substantial portion of the sensor (e.g., in vivo portion or fluid contact portion). As another exemplary embodiment, a sensor such as described in more detail with reference to FIGS. **1A** to **1C** is formed from a 0.004 inch conductive wire and vapor deposited with an insulator material for a diameter of about 0.005 inches along a substantial portion of the sensor (e.g., in vivo portion or fluid contact portion), after which a desired electroactive surface area can be exposed. In the above two exemplary embodiments, the reference electrode can be located remote from the working electrode (e.g., formed from the conductive wire). While the devices and methods described herein are directed to use within the host's blood stream, one skilled in the art will recognize that the systems, configurations, methods and principles of operation described herein can be incorporated into other analyte sensing devices, such as but not limited to subcutaneous devices or wholly implantable devices such as described in U.S. Publication 2006-0016700, which is incorporated herein by reference in its entirety.

**[0301]** FIG. **3C** is a cross section of the sensor shown in FIG. **3B**, taken at line C-C. Preferably, a membrane system (see FIG. **3C**) is deposited over the electroactive surfaces of the sensor and includes a plurality of domains or layers, such as described in more detail below, with reference to FIGS. **3B** and **3C**. The membrane system can be deposited on the exposed electroactive surfaces using known thin film techniques (for example, spraying, electro-depositing, dipping, and the like). In one exemplary embodiment, each domain is deposited by dipping the sensor into a solution and drawing out the sensor at a speed that provides the appropriate domain thickness. In general, the membrane system can be disposed over (deposited on) the electroactive surfaces using methods appreciated by one skilled in the art.

**[0302]** In general, the membrane system includes a plurality of domains, for example, an electrode domain **347**, an interference domain **348**, an enzyme domain **349** (for example, including glucose oxidase), and a resistance domain **350**, as shown in FIG. **3C**, and can include a high oxygen solubility domain, and/or a bioprotective domain (not shown), such as is described in more detail in U.S. Publication No. US-2005-0245799-A1, and such as is described in more detail below. The membrane system can be deposited on the exposed electroactive surfaces using known thin film techniques (for example, vapor deposition, spraying, electro-depositing, dipping, and the like). In alternative embodiments, however, other vapor deposition processes (e.g., physical and/or chemical vapor deposition processes) can be useful for providing one or more of the insulating and/or membrane layers, including ultrasonic vapor deposition, electrostatic deposition, evaporative deposition, deposition by sputtering, pulsed laser deposition, high velocity oxygen fuel deposition, thermal evaporator deposition, electron beam evaporator deposition, deposition by reactive sputtering molecular beam epitaxy, atmospheric pressure chemical vapor deposition (CVD), atomic layer CVD, hot wire CVD, low-pressure CVD, microwave plasma-assisted CVD, plasma-enhanced CVD, rapid thermal CVD, remote plasma-enhanced CVD, and ultra-high vacuum CVD, for example. However, the membrane system can be disposed over (or deposited on) the electroactive surfaces using any known method, as will be appreciated by one skilled in the art.

**[0303]** In some embodiments, one or more domains of the membrane systems are formed from materials such as described above in connection with the porous layer, such as silicone, polytetrafluoroethylene, polyethylene-co-tetrafluoroethylene, polyolefin, polyester, polycarbonate, biostable polytetrafluoroethylene, homopolymers, copolymers, terpolymers of polyurethanes, polypropylene (PP), polyvinylchloride (PVC), polyvinylidene fluoride (PVDF), polybutylene terephthalate (PBT), polymethylmethacrylate (PMMA), polyether ether ketone (PEEK), polyurethanes, cellulosic polymers, polysulfones and block copolymers thereof including, for example, di-block, tri-block, alternating, random and graft copolymers. U.S. Publication No. US-2005-0245799-A1 describes biointerface and membrane system configurations and materials that may be applied to the preferred embodiments.

#### Electrode Domain

**[0304]** In selected embodiments, the membrane system comprises an electrode domain. The electrode domain **347** is provided to ensure that an electrochemical reaction occurs between the electroactive surfaces of the working electrode and the reference electrode, and thus the electrode domain **347** is preferably situated more proximal to the electroactive surfaces than the interference and/or enzyme domain. Preferably, the electrode domain includes a coating that maintains a layer of water at the electrochemically reactive surfaces of the sensor. In other words, the electrode domain is present to provide an environment between the surfaces of the working electrode and the reference electrode, which facilitates an electrochemical reaction between the electrodes. For example, a humectant in a binder material can be employed as an electrode domain; this allows for the full transport of ions in the aqueous environment. The electrode domain can also assist in stabilizing the operation of the sensor by accelerating electrode start-up and drifting problems caused by inadequate

electrolyte. The material that forms the electrode domain can also provide an environment that protects against pH-mediated damage that can result from the formation of a large pH gradient due to the electrochemical activity of the electrodes.

[0305] In one embodiment, the electrode domain 347 includes a flexible, water-swellaable, hydrogel film having a "dry film" thickness of from about 0.05 micron or less to about 20 microns or more, more preferably from about 0.05, 0.1, 0.15, 0.2, 0.25, 0.3, 0.35, 0.4, 0.45, 0.5, 1, 1.5, 2, 2.5, 3, or 3.5 microns to about 4, 5, 6, 7, 8, 9, 10, 11, 12, 13, 14, 15, 16, 17, 18, 19, or 19.5 microns, and more preferably still from about 2, 2.5 or 3 microns to about 3.5, 4, 4.5, or 5 microns. "Dry film" thickness refers to the thickness of a cured film cast from a coating formulation by standard coating techniques.

[0306] In certain embodiments, the electrode domain 347 is formed of a curable mixture of a urethane polymer and a hydrophilic polymer. Particularly preferred coatings are formed of a polyurethane polymer having carboxylate or hydroxyl functional groups and non-ionic hydrophilic polyether segments, wherein the polyurethane polymer is crosslinked with a water-soluble carbodiimide (e.g., 1-ethyl-3-(3-dimethylaminopropyl)carbodiimide (EDC)) in the presence of polyvinylpyrrolidone and cured at a moderate temperature of about 50° C.

[0307] In some preferred embodiments, the electrode domain 347 is formed from a hydrophilic polymer such as polyvinylpyrrolidone (PVP). An electrode domain formed from PVP has been shown to reduce break-in time of analyte sensors; for example, a glucose sensor utilizing a cellulosic-based interference domain such as described in more detail below.

[0308] Preferably, the electrode domain is deposited by vapor deposition, spray coating, dip coating, or other thin film techniques on the electroactive surfaces of the sensor. In one preferred embodiment, the electrode domain is formed by dip-coating the electroactive surfaces in an electrode layer solution and curing the domain for a time of from about 15 minutes to about 30 minutes at a temperature of from about 40° C. to about 55° C. (and can be accomplished under vacuum (e.g., 20 to 30 mmHg)). In embodiments wherein dip-coating is used to deposit the electrode domain, a preferred insertion rate of from about 1 to about 3 inches per minute into the electrode layer solution, with a preferred dwell time of from about 0.5 to about 2 minutes in the electrode layer solution, and a preferred withdrawal rate of from about 0.25 to about 2 inches per minute from the electrode layer solution provide a functional coating. However, values outside of those set forth above can be acceptable or even desirable in certain embodiments, for example, depending upon solution viscosity and solution surface tension, as is appreciated by one skilled in the art. In one embodiment, the electroactive surfaces of the electrode system are dip-coated one time (one layer) and cured at 50° C. under vacuum for 20 minutes.

[0309] Although an independent electrode domain 347 is described herein, in some embodiments sufficient hydrophilicity can be provided in the interference domain and/or enzyme domain (the domain adjacent to the electroactive surfaces) so as to provide for the full transport of ions in the aqueous environment (e.g. without a distinct electrode domain). In these embodiments, an electrode domain is not necessary.

#### Interference Domain

[0310] Interferents are molecules or other species that are reduced or oxidized at the electrochemically reactive surfaces of the sensor, either directly or via an electron transfer agent, to produce a false positive analyte signal. In preferred embodiments, an interference domain 348 is provided that substantially restricts, resists, or blocks the flow of one or more interfering species. Some known interfering species for a glucose sensor, as described in more detail above, include acetaminophen, ascorbic acid, bilirubin, cholesterol, creatinine, dopamine, ephedrine, ibuprofen, L-dopa, methyl dopa, salicylate, tetracycline, tolazamide, tolbutamide, triglycerides, and uric acid. In general, the interference domain of the preferred embodiments is less permeable to one or more of the interfering species than to the analyte, e.g., glucose.

[0311] In one embodiment, the interference domain 348 is formed from one or more cellulosic derivatives. In general, cellulosic derivatives include polymers such as cellulose acetate, cellulose acetate butyrate, 2-hydroxyethyl cellulose, cellulose acetate phthalate, cellulose acetate propionate, cellulose acetate trimellitate, and the like.

[0312] In one preferred embodiment, the interference domain 348 is formed from cellulose acetate butyrate. Cellulose acetate butyrate with a molecular weight of about 10,000 daltons to about 75,000 daltons, preferably from about 15,000, 20,000, or 25,000 daltons to about 50,000, 55,000, 60,000, 65,000, or 70,000 daltons, and more preferably about 20,000 daltons is employed. In certain embodiments, however, higher or lower molecular weights can be preferred. Additionally, a casting solution or dispersion of cellulose acetate butyrate at a weight percent of about 15% to about 25%, preferably from about 15%, 16%, 17%, 18%, 19% to about 20%, 21%, 22%, 23%, 24% or 25%, and more preferably about 18% is preferred. Preferably, the casting solution includes a solvent or solvent system, for example an acetone: ethanol solvent system. Higher or lower concentrations can be preferred in certain embodiments. A plurality of layers of cellulose acetate butyrate can be advantageously combined to form the interference domain in some embodiments, for example, three layers can be employed. It can be desirable to employ a mixture of cellulose acetate butyrate components with different molecular weights in a single solution, or to deposit multiple layers of cellulose acetate butyrate from different solutions comprising cellulose acetate butyrate of different molecular weights, different concentrations, and/or different chemistries (e.g., functional groups). It can also be desirable to include additional substances in the casting solutions or dispersions, e.g., functionalizing agents, crosslinking agents, other polymeric substances, substances capable of modifying the hydrophilicity/hydrophobicity of the resulting layer, and the like.

[0313] In one alternative embodiment, the interference domain 348 is formed from cellulose acetate. Cellulose acetate with a molecular weight of about 30,000 daltons or less to about 100,000 daltons or more, preferably from about 35,000, 40,000, or 45,000 daltons to about 55,000, 60,000, 65,000, 70,000, 75,000, 80,000, 85,000, 90,000, or 95,000 daltons, and more preferably about 50,000 daltons is preferred. Additionally, a casting solution or dispersion of cellulose acetate at a weight percent of about 3% to about 10%, preferably from about 3.5%, 4.0%, 4.5%, 5.0%, 5.5%, 6.0%, or 6.5% to about 7.5%, 8.0%, 8.5%, 9.0%, or 9.5%, and more preferably about 8% is preferred. In certain embodiments, however, higher or lower molecular weights and/or cellulose

acetate weight percentages can be preferred. It can be desirable to employ a mixture of cellulose acetates with molecular weights in a single solution, or to deposit multiple layers of cellulose acetate from different solutions comprising cellulose acetates of different molecular weights, different concentrations, or different chemistries (e.g., functional groups). It can also be desirable to include additional substances in the casting solutions or dispersions such as described in more detail above.

**[0314]** Layer(s) prepared from combinations of cellulose acetate and cellulose acetate butyrate, or combinations of layer(s) of cellulose acetate and layer(s) of cellulose acetate butyrate can also be employed to form the interference domain **348**.

**[0315]** In some alternative embodiments, additional polymers, such as Nafion®, can be used in combination with cellulosic derivatives to provide equivalent and/or enhanced function of the interference domain **348**. As one example, a 5 wt % Nafion® casting solution or dispersion can be used in combination with a 8 wt % cellulose acetate casting solution or dispersion, e.g., by dip coating at least one layer of cellulose acetate and subsequently dip coating at least one layer Nafion® onto a needle-type sensor such as described with reference to the preferred embodiments. Any number of coatings or layers formed in any order may be suitable for forming the interference domain of the preferred embodiments.

**[0316]** In some alternative embodiments, more than one cellulosic derivative can be used to form the interference domain **348** of the preferred embodiments. In general, the formation of the interference domain on a surface utilizes a solvent or solvent system in order to solvate the cellulosic derivative (or other polymer) prior to film formation thereon. In preferred embodiments, acetone and ethanol are used as solvents for cellulose acetate; however one skilled in the art appreciates the numerous solvents that are suitable for use with cellulosic derivatives (and other polymers). Additionally, one skilled in the art appreciates that the preferred relative amounts of solvent can be dependent upon the cellulosic derivative (or other polymer) used, its molecular weight, its method of deposition, its desired thickness, and the like. However, a percent solute of from about 1% to about 25% is preferably used to form the interference domain solution so as to yield an interference domain having the desired properties. The cellulosic derivative (or other polymer) used, its molecular weight, method of deposition, and desired thickness can be adjusted, depending upon one or more other of the parameters, and can be varied accordingly as is appreciated by one skilled in the art.

**[0317]** In some alternative embodiments, other polymer types that can be utilized as a base material for the interference domain **348** including polyurethanes, polymers having pendant ionic groups, and polymers having controlled pore size, for example. In one such alternative embodiment, the interference domain includes a thin, hydrophobic membrane that is non-swelling and restricts diffusion of low molecular weight species. The interference domain **348** is permeable to relatively low molecular weight substances, such as hydrogen peroxide, but restricts the passage of higher molecular weight substances, including glucose and ascorbic acid. Other systems and methods for reducing or eliminating interference species that can be applied to the membrane system of the preferred embodiments are described in U.S. Publication No. US-2005-0115832-A1, U.S. Publication No. US-2005-0176136-A1, U.S. Publication No. US-2005-0161346-A1,

and U.S. Publication No. US-2005-0143635-A1, U.S. Publication No. US-2006-0020187-A1, and U.S. patent application Ser. No. 11/543,707 filed on Oct. 4, 2008, U.S. patent application Ser. No. 11/543,539 filed on Oct. 4, 2008, U.S. patent application Ser. No. 11/543,683 filed on Oct. 4, 2008, and U.S. patent application Ser. No. 11/543,734 filed on Oct. 4, 2008, each entitled "DUAL ELECTRODE SYSTEM FOR A CONTINUOUS ANALYTE SENSOR," all of which are incorporated herein by reference in their entirety. In some alternative embodiments, a distinct interference domain is not included.

**[0318]** In preferred embodiments, the interference domain **348** is deposited directly onto the electroactive surfaces of the sensor for a domain thickness of from about 0.05 micron or less to about 20 microns or more, more preferably from about 0.05, 0.1, 0.15, 0.2, 0.25, 0.3, 0.35, 0.4, 0.45, 0.5, 1, 1.5, 2, 2.5, 3, or 3.5 microns to about 4, 5, 6, 7, 8, 9, 10, 11, 12, 13, 14, 15, 16, 17, 18, 19, or 19.5 microns, and more preferably still from about 1, 1.5 or 2 microns to about 2.5 or 3 microns. Thicker membranes can also be desirable in certain embodiments, but thinner membranes are generally preferred because they can have a lower impact on the rate of diffusion of hydrogen peroxide from the enzyme membrane to the electrodes.

**[0319]** In general, the membrane systems of the preferred embodiments can be formed and/or deposited on the exposed electroactive surfaces (e.g., one or more of the working and reference electrodes) using known thin film techniques (for example, casting, spray coating, drawing down, electro-depositing, dip coating, and the like), however casting or other known application techniques can also be utilized. Preferably, the interference domain is deposited by vapor deposition, spray coating, or dip coating. In one exemplary embodiment of a needle-type (transcutaneous) sensor such as described herein, the interference domain is formed by dip coating the sensor into an interference domain solution using an insertion rate of from about 20 inches/min to about 60 inches/min, preferably 40 inches/min, a dwell time of from about 0 minute to about 5 seconds, preferably 0 seconds, and a withdrawal rate of from about 20 inches/minute to about 60 inches/minute, preferably about 40 inches/minute, and curing (drying) the domain from about 1 minute to about 30 minutes, preferably from about 3 minutes to about 15 minutes (and can be accomplished at room temperature or under vacuum (e.g., 20 to 30 mmHg)). In one exemplary embodiment including cellulose acetate butyrate interference domain, a 3-minute cure (i.e., dry) time is preferred between each layer applied. In another exemplary embodiment employing a cellulose acetate interference domain, a 15 minute cure (i.e., dry) time is preferred between each layer applied.

**[0320]** The dip process can be repeated at least one time and up to 10 times or more. The preferred number of repeated dip processes depends upon the cellulosic derivative(s) used, their concentration, conditions during deposition (e.g., dipping) and the desired thickness (e.g., sufficient thickness to provide functional blocking of (or resistance to) certain interferents), and the like. In some embodiments, 1 to 3 microns may be preferred for the interference domain thickness; however, values outside of these can be acceptable or even desirable in certain embodiments, for example, depending upon viscosity and surface tension, as is appreciated by one skilled in the art. In one exemplary embodiment, an interference domain is formed from three layers of cellulose acetate butyrate. In another exemplary embodiment, an interference domain is formed from 10 layers of cellulose acetate. In

alternative embodiments, the interference domain can be formed using any known method and combination of cellulose acetate and cellulose acetate butyrate, as will be appreciated by one skilled in the art.

[0321] In some embodiments, the electroactive surface can be cleaned prior to application of the interference domain 348. In some embodiments, the interference domain 348 of the preferred embodiments can be useful as a bioprotective or biocompatible domain, namely, a domain that interfaces with host tissue when implanted in an animal (e.g., a human) due to its stability and biocompatibility.

#### Enzyme Domain

[0322] In preferred embodiments, the membrane system further includes an enzyme domain 349 disposed more distally from the electroactive surfaces than the interference domain 348; however other configurations can be desirable. In the preferred embodiments, the enzyme domain provides an enzyme to catalyze the reaction of the analyte and its co-reactant, as described in more detail below. In the preferred embodiments of a glucose sensor, the enzyme domain includes glucose oxidase; however other oxidases, for example, galactose oxidase or uricase oxidase, can also be used.

[0323] For an enzyme-based electrochemical glucose sensor to perform well, the sensor's response is preferably limited by neither enzyme activity nor co-reactant concentration. Because enzymes, including glucose oxidase, are subject to deactivation as a function of time even in ambient conditions, this behavior is compensated for in forming the enzyme domain. Preferably, the enzyme domain is constructed of aqueous dispersions of colloidal polyurethane polymers including the enzyme. However, in alternative embodiments the enzyme domain is constructed from an oxygen enhancing material, for example, silicone, or fluorocarbon, in order to provide a supply of excess oxygen during transient ischemia. Preferably, the enzyme is immobilized within the domain. See, e.g., U.S. Publication No. US-2005-0054909-A1.

[0324] In preferred embodiments, the enzyme domain is deposited onto the interference domain for a domain thickness of from about 0.05 micron or less to about 20 microns or more, more preferably from about 0.05, 0.1, 0.15, 0.2, 0.25, 0.3, 0.35, 0.4, 0.45, 0.5, 1, 1.5, 2, 2.5, 3, or 3.5 microns to about 4, 5, 6, 7, 8, 9, 10, 11, 12, 13, 14, 15, 16, 17, 18, 19, or 19.5 microns, and more preferably still from about 2, 2.5 or 3 microns to about 3.5, 4, 4.5, or 5 microns. However in some embodiments, the enzyme domain can be deposited directly onto the electroactive surfaces. Preferably, the enzyme domain is deposited by spray or dip coating. In one embodiment of needle-type (transcutaneous) sensor such as described herein, the enzyme domain is formed by dip coating the interference domain coated sensor into an enzyme domain solution and curing the domain for from about 15 to about 30 minutes at a temperature of from about 40° C. to about 55° C. (and can be accomplished under vacuum (e.g., 20 to 30 mmHg)). In embodiments wherein dip coating is used to deposit the enzyme domain at room temperature, a preferred insertion rate of from about 0.25 inch per minute to about 3 inches per minute, with a preferred dwell time of from about 0.5 minutes to about 2 minutes, and a preferred withdrawal rate of from about 0.25 inch per minute to about 2 inches per minute provides a functional coating. However, values outside of those set forth above can be acceptable or even desirable in certain embodiments, for example, depend-

ing upon viscosity and surface tension, as is appreciated by one skilled in the art. In one embodiment, the enzyme domain is formed by dip coating two times (namely, forming two layers) in an enzyme domain solution and curing at 50° C. under vacuum for 20 minutes. However, in some embodiments, the enzyme domain can be formed by dip coating and/or spray coating one or more layers at a predetermined concentration of the coating solution, insertion rate, dwell time, withdrawal rate, and/or desired thickness.

#### Resistance Domain

[0325] In preferred embodiments, the membrane system includes a resistance domain 350 disposed more distal from the electroactive surfaces than the enzyme domain. Although the following description is directed to a resistance domain for a glucose sensor, the resistance domain can be modified for other analytes and co-reactants as well.

[0326] There exists a molar excess of glucose relative to the amount of oxygen in blood; that is, for every free oxygen molecule in extracellular fluid, there are typically more than 100 glucose molecules present (see Updike et al., *Diabetes Care* 5:207-21 (1982)). However, an immobilized enzyme-based glucose sensor employing oxygen as co-reactant is preferably supplied with oxygen in non-rate-limiting excess in order for the sensor to respond linearly to changes in glucose concentration, while not responding to changes in oxygen concentration. Specifically, when a glucose-monitoring reaction is oxygen limited, linearity is not achieved above minimal concentrations of glucose. Without a semipermeable membrane situated over the enzyme domain to control the flux of glucose and oxygen, a linear response to glucose levels can be obtained only for glucose concentrations of up to about 40 mg/dL. However, in a clinical setting, a linear response to glucose levels is desirable up to at least about 400 mg/dL.

[0327] The resistance domain includes a semipermeable membrane that controls the flux of oxygen and glucose to the underlying enzyme domain, preferably rendering oxygen in a non-rate-limiting excess. As a result, the upper limit of linearity of glucose measurement is extended to a much higher value than that which is achieved without the resistance domain. In one embodiment, the resistance domain exhibits an oxygen to glucose permeability ratio of from about 50:1 or less to about 400:1 or more, preferably about 200:1. As a result, one-dimensional reactant diffusion is adequate to provide excess oxygen at all reasonable glucose and oxygen concentrations found in the subcutaneous matrix (See Rhodes et al., *Anal. Chem.*, 66:1520-1529 (1994)).

[0328] In alternative embodiments, a lower ratio of oxygen-to-glucose can be sufficient to provide excess oxygen by using a high oxygen solubility domain (for example, a silicone or fluorocarbon-based material or domain) to enhance the supply/transport of oxygen to the enzyme domain. If more oxygen is supplied to the enzyme, then more glucose can also be supplied to the enzyme without creating an oxygen rate-limiting excess. In alternative embodiments, the resistance domain is formed from a silicone composition, such as is described in U.S. Publication No. US-2005-0090607-A1.

[0329] In a preferred embodiment, the resistance domain includes a polyurethane membrane with both hydrophilic and hydrophobic regions to control the diffusion of glucose and oxygen to an analyte sensor, the membrane being fabricated easily and reproducibly from commercially available materials. A suitable hydrophobic polymer component is a polyurethane, or polyetherurethaneurea. Polyurethane is a polymer

produced by the condensation reaction of a diisocyanate and a difunctional hydroxyl-containing material. A polyurethaneurea is a polymer produced by the condensation reaction of a diisocyanate and a difunctional amine-containing material. Preferred diisocyanates include aliphatic diisocyanates containing from about 4 to about 8 methylene units. Diisocyanates containing cycloaliphatic moieties can also be useful in the preparation of the polymer and copolymer components of the membranes of preferred embodiments. The material that forms the basis of the hydrophobic matrix of the resistance domain can be any of those known in the art as appropriate for use as membranes in sensor devices and as having sufficient permeability to allow relevant compounds to pass through it, for example, to allow an oxygen molecule to pass through the membrane from the sample under examination in order to reach the active enzyme or electrochemical electrodes. Examples of materials which can be used to make non-polyurethane type membranes include vinyl polymers, polyethers, polyesters, polyamides, inorganic polymers such as polysiloxanes and polycarbosiloxanes, natural polymers such as cellulosic and protein based materials, and mixtures or combinations thereof.

**[0330]** In a preferred embodiment, the hydrophilic polymer component is polyethylene oxide. For example, one useful hydrophobic-hydrophilic copolymer component is a polyurethane polymer that includes about 20% hydrophilic polyethylene oxide. The polyethylene oxide portions of the copolymer are thermodynamically driven to separate from the hydrophobic portions of the copolymer and the hydrophobic polymer component. The 20% polyethylene oxide-based soft segment portion of the copolymer used to form the final blend affects the water pick-up and subsequent glucose permeability of the membrane.

**[0331]** In some embodiments, the resistance domain is formed from a silicone polymer modified to allow analyte (e.g., glucose) transport.

**[0332]** In some embodiments, the resistance domain is formed from a silicone polymer/hydrophobic-hydrophilic polymer blend. In one embodiment, The hydrophobic-hydrophilic polymer for use in the blend may be any suitable hydrophobic-hydrophilic polymer, including but not limited to components such as polyvinylpyrrolidone (PVP), polyhydroxyethyl methacrylate, polyvinylalcohol, polyacrylic acid, polyethers such as polyethylene glycol or polypropylene oxide, and copolymers thereof, including, for example, diblock, tri-block, alternating, random, comb, star, dendritic, and graft copolymers (block copolymers are discussed in U.S. Pat. Nos. 4,803,243 and 4,686,044, which are incorporated herein by reference). In one embodiment, the hydrophobic-hydrophilic polymer is a copolymer of poly(ethylene oxide) (PEO) and poly(propylene oxide) (PPO). Suitable such polymers include, but are not limited to, PEO-PPO diblock copolymers, PPO-PEO-PPO triblock copolymers, PEO-PPO-PEO triblock copolymers, alternating block copolymers of PEO-PPO, random copolymers of ethylene oxide and propylene oxide, and blends thereof. In some embodiments, the copolymers may be optionally substituted with hydroxy substituents. Commercially available examples of PEO and PPO copolymers include the PLURONIC® brand of polymers available from BASF®. In one embodiment, PLURONIC® F-127 is used. Other PLURONIC® polymers include PPO-PEO-PPO triblock copolymers (e.g., PLURONIC® R products). Other suitable commercial polymers include, but are not limited to, SYNPERONICS® prod-

ucts available from UNIQEMA®. Co-pending U.S. patent application Ser. No. 11/404,417 and entitled, "SILICONE BASED MEMBRANES FOR USE IN IMPLANTABLE GLUCOSE SENSORS," which is incorporated herein by reference in its entirety, describes systems and methods suitable for the resistance and/or other domains of the membrane system of the preferred embodiments.

**[0333]** In preferred embodiments, the resistance domain is deposited onto the enzyme domain to yield a domain thickness of from about 0.05 microns or less to about 20 microns or more, more preferably from about 0.05, 0.1, 0.15, 0.2, 0.25, 0.3, 0.35, 0.4, 0.45, 0.5, 1, 1.5, 2, 2.5, 3, or 3.5 microns to about 4, 5, 6, 7, 8, 9, 10, 11, 12, 13, 14, 15, 16, 17, 18, 19, or 19.5 microns, and more preferably still from about 2, 2.5 or 3 microns to about 3.5, 4, 4.5, or 5 microns. Preferably, the resistance domain is deposited onto the enzyme domain by vapor deposition, spray coating, or dip coating. In one preferred embodiment, spray coating is the preferred deposition technique. The spraying process atomizes and mists the solution, and therefore most or all of the solvent is evaporated prior to the coating material settling on the underlying domain, thereby minimizing contact of the solvent with the enzyme.

**[0334]** In another preferred embodiment, physical vapor deposition (e.g., ultrasonic vapor deposition) is used for coating one or more of the membrane domain(s) onto the electrodes, wherein the vapor deposition apparatus and process include an ultrasonic nozzle that produces a mist of micro-droplets in a vacuum chamber. In these embodiments, the micro-droplets move turbulently within the vacuum chamber, isotropically impacting and adhering to the surface of the substrate. Advantageously, vapor deposition as described above can be implemented to provide high production throughput of membrane deposition processes (e.g., at least about 20 to about 200 or more electrodes per chamber), greater consistency of the membrane on each sensor, and increased uniformity of sensor performance, for example, as described below.

**[0335]** In some embodiments, depositing the resistance domain (for example, as described in the preferred embodiments above) includes formation of a membrane system that substantially blocks or resists ascorbate (a known electrochemical interferant in hydrogen peroxide-measuring glucose sensors). While not wishing to be bound by theory, it is believed that during the process of depositing the resistance domain as described in the preferred embodiments, a structural morphology is formed that is characterized in that ascorbate does not substantially permeate therethrough.

**[0336]** In a preferred embodiment, the resistance domain is deposited on the enzyme domain by spray coating a solution of from about 1 wt. % to about 5 wt. % polymer and from about 95 wt. % to about 99 wt. % solvent. In spraying a solution of resistance domain material, including a solvent, onto the enzyme domain, it is desirable to mitigate or substantially reduce any contact with enzyme of any solvent in the spray solution that can deactivate the underlying enzyme of the enzyme domain. Tetrahydrofuran (THF) is one solvent that minimally or negligibly affects the enzyme of the enzyme domain upon spraying. Other solvents can also be suitable for use, as is appreciated by one skilled in the art.

**[0337]** Although a variety of spraying or deposition techniques can be used, spraying the resistance domain material and rotating the sensor at least one time by 180° can typically provide adequate coverage by the resistance domain. Spray-

ing the resistance domain material and rotating the sensor at least two times by 120° provides even greater coverage (one layer of 360° coverage), thereby ensuring resistivity to glucose, such as is described in more detail above.

**[0338]** In preferred embodiments, the resistance domain is spray coated and subsequently cured for a time of from about 15 minutes to about 90 minutes at a temperature of from about 40° C. to about 60° C. (and can be accomplished under vacuum (e.g., from 20 to 30 mmHg)). A cure time of up to about 90 minutes or more can be advantageous to ensure complete drying of the resistance domain.

**[0339]** In one embodiment, the resistance domain is formed by spray coating at least six layers (namely, rotating the sensor seventeen times by 120° for at least six layers of 360° coverage) and curing at 50° C. under vacuum for 60 minutes. However, the resistance domain can be formed by dip coating or spray coating any layer or plurality of layers, depending upon the concentration of the solution, insertion rate, dwell time, withdrawal rate, and/or the desired thickness of the resulting film. Additionally, curing in a convention oven can also be employed.

**[0340]** In certain embodiments, a variable frequency microwave oven can be used to cure the membrane domains/layers. In general, microwave ovens directly excite the rotational mode of solvents. Consequently, microwave ovens cure coatings from the inside out rather than from the outside in as with conventional convection ovens. This direct rotational mode excitation is responsible for the typically observed “fast” curing within a microwave oven. In contrast to conventional microwave ovens, which rely upon a fixed frequency of emission that can cause arcing of dielectric (metallic) substrates if placed within a conventional microwave oven, Variable Frequency Microwave (VFM) ovens emit thousands of frequencies within 100 milliseconds, which substantially eliminates arcing of dielectric substrates. Consequently, the membrane domains/layers can be cured even after deposition on metallic electrodes as described herein. While not wishing to be bound by theory, it is believed that VFM curing can increase the rate and completeness of solvent evaporation from a liquid membrane solution applied to a sensor, as compared to the rate and completeness of solvent evaporation observed for curing in conventional convection ovens.

**[0341]** In certain embodiments, VFM is can be used together with convection oven curing to further accelerate cure time. In some sensor applications wherein the membrane is cured prior to application on the electrode (see, for example, U.S. Publication No. US-2005-0245799-A1, which is incorporated herein by reference in its entirety), conventional microwave ovens (e.g., fixed frequency microwave ovens) can be used to cure the membrane layer.

#### Treatment of Interference Domain/Membrane System

**[0342]** Although the above-described methods generally include a curing step in formation of the membrane system, including the interference domain, the preferred embodiments further include an additional treatment step, which can be performed directly after the formation of the interference domain and/or some time after the formation of the entire membrane system (or anytime in between). In some embodiments, the additional treatment step is performed during (or in combination with) sterilization of the sensor.

**[0343]** In some embodiments, the membrane system (or interference domain) is treated by exposure to ionizing radiation, for example, electron beam radiation, UV radiation,

X-ray radiation, gamma radiation, and the like. Alternatively, the membrane can be exposed to visible light when suitable photoinitiators are incorporated into the interference domain. While not wishing to be bound by theory, it is believed that exposing the interference domain to ionizing radiation substantially crosslinks the interference domain and thereby creates a tighter, less permeable network than an interference domain that has not been exposed to ionizing radiation.

**[0344]** In some embodiments, the membrane system (or interference domain) is crosslinked by forming free radicals, which may include the use of ionizing radiation, thermal initiators, chemical initiators, photoinitiators (e.g., UV and visible light), and the like. Any suitable initiator or any suitable initiator system can be employed, for example,  $\alpha$ -hydroxyketone,  $\alpha$ -aminoketone, ammonium persulfate (APS), redox systems such as APS/bisulfite, or potassium permanganate. Suitable thermal initiators include but are not limited to potassium persulfate, ammonium persulfate, sodium persulfate, and mixtures thereof.

**[0345]** In embodiments wherein electron beam radiation is used to treat the membrane system (or interference domain), a preferred exposure time is from about 6 k or 12 kGy to about 25 or 50 kGy, more preferably about 25 kGy. However, one skilled in the art appreciates that choice of molecular weight, composition of cellulosic derivative (or other polymer), and/or the thickness of the layer can affect the preferred exposure time of membrane to radiation. Preferably, the exposure is sufficient for substantially crosslinking the interference domain to form free radicals, but does not destroy or significantly break down the membrane or does not significantly damage the underlying electroactive surfaces.

**[0346]** In embodiments wherein UV radiation is employed to treat the membrane, UV rays from about 200 nm to about 400 nm are preferred; however values outside of this range can be employed in certain embodiments, dependent upon the cellulosic derivative and/or other polymer used.

**[0347]** In some embodiments, for example, wherein photoinitiators are employed to crosslink the interference domain, one or more additional domains can be provided adjacent to the interference domain for preventing delamination that may be caused by the crosslinking treatment. These additional domains can be “tie layers” (i.e., film layers that enhance adhesion of the interference domain to other domains of the membrane system). In one exemplary embodiment, a membrane system is formed that includes the following domains: resistance domain, enzyme domain, electrode domain, and cellulosic-based interference domain, wherein the electrode domain is configured to ensure adhesion between the enzyme domain and the interference domain. In embodiments wherein photoinitiators are employed to crosslink the interference domain, UV radiation of greater than about 290 nm is preferred. Additionally, from about 0.01 to about 1 wt % photoinitiator is preferred weight-to-weight with a preselected cellulosic polymer (e.g., cellulose acetate); however values outside of this range can be desirable dependent upon the cellulosic polymer selected.

**[0348]** In general, sterilization of the transcutaneous sensor can be completed after final assembly, utilizing methods such as electron beam radiation, gamma radiation, glutaraldehyde treatment, and the like. The sensor can be sterilized prior to or after packaging. In an alternative embodiment, one or more sensors can be sterilized using variable frequency microwave chamber(s), which can increase the speed and reduce the cost of the sterilization process. In another alternative embodi-

ment, one or more sensors can be sterilized using ethylene oxide (EtO) gas sterilization, for example, by treating with 100% ethylene oxide, which can be used when the sensor electronics are not detachably connected to the sensor and/or when the sensor electronics must undergo a sterilization process. In one embodiment, one or more packaged sets of transcutaneous sensors (e.g., 1, 2, 3, 4, or 5 sensors or more) are sterilized simultaneously.

#### Therapeutic Agents

**[0349]** A variety of therapeutic (bioactive) agents can be used with the analyte sensor system of the preferred embodiments, such as the analyte sensor system of the embodiments shown in FIGS. 1A-3C. In some embodiments, the therapeutic agent is an anticoagulant. The term "anticoagulant" as used herein is a broad term, and is to be given its ordinary and customary meaning to a person of ordinary skill in the art (and is not to be limited to a special or customized meaning), and refers without limitation to a substance that prevents coagulation (e.g., minimizes, reduces, or stops clotting of blood). In some embodiments, an anticoagulant is included in the analyte sensor system to prevent coagulation within or on the sensor (e.g., within or on the catheter or within or on the sensor). Suitable anticoagulants for incorporation into the sensor system include, but are not limited to, vitamin K antagonists (e.g., Acenocoumarol, Clorindione, Dicoumarol (Dicoumarol), Diphenadione, Ethyl biscoumacetate, Phenprocoumon, Phenindione, Ticloamarol, or Warfarin), heparin group anticoagulants (e.g., Platelet aggregation inhibitors: Antithrombin III, Bemiparin, Dalteparin, Danaparoid, Enoxaparin, Heparin, Nadroparin, Parnaparin, Reviparin, Sulodexide, Tinzaparin), other platelet aggregation inhibitors (e.g., Abciximab, Acetylsalicylic acid (Aspirin), Aloxiprin, Beraprost, Ditzazole, Carbasalate calcium, Cloricromen, Clopidogrel, Dipyridamole, Epoprostenol, Eptifibatide, Indobufen, Iloprost, Picotamide, Ticlopidine, Tirofiban, Trepstinil, Triflusal), enzymes (e.g., Alteplase, Ancrod, Anistreplase, Brinase, Drotrecogin alfa, Fibrinolysin, Protein C, Reteplase, Saruplase, Streptokinase, Tenecteplase, Urokinase), direct thrombin inhibitors (e.g., Argatroban, Bivalirudin, Desirudin, Lepirudin, Melagatran, Ximelagatran, other antithrombotics (e.g., Dabigatran, Defibrotide, Dermatan sulfate, Fondaparinux, Rivaroxaban) and the like.

**[0350]** In one embodiment, heparin is incorporated into the analyte sensor system. In a further embodiment, heparin is coated on the catheter and/or sensor by dipping or spraying. While not wishing to be bound by theory, it is believed that heparin coated on the catheter and/or sensor prevents aggregation and clotting of blood on the analyte sensor system, thereby preventing thromboembolization (e.g., prevention of blood flow by the thrombus or clot) and/or subsequent complications.

**[0351]** In some embodiments, the membrane system of the preferred embodiments preferably include a bioactive agent, which is incorporated into at least a portion of the membrane system, or which is incorporated into the device and adapted to diffuse through the membrane.

**[0352]** There are a variety of systems and methods by which the bioactive agent is incorporated into the membrane of the preferred embodiments. In some embodiments, the bioactive agent is incorporated at the time of manufacture of the membrane system. For example, the bioactive agent can be blended prior to curing the membrane system, or subsequent to membrane system manufacture, for example, by

coating, imbibing, solvent-casting, or sorption of the bioactive agent into the membrane system. Although the bioactive agent is preferably incorporated into the membrane system, in some embodiments the bioactive agent can be administered concurrently with, prior to, or after insertion of the device intravascularly, for example, by oral administration, or locally, for example, by subcutaneous injection near the implantation site. A combination of bioactive agent incorporated in the membrane system and bioactive agent administration locally and/or systemically can be preferred in certain embodiments.

**[0353]** In general, a bioactive agent can be incorporated into the membrane system, and/or incorporated into the device and adapted to diffuse therefrom, in order to modify the tissue response of the host to the membrane. In some embodiments, the bioactive agent is incorporated only into a portion of the membrane system adjacent to the sensing region of the device, over the entire surface of the device except over the sensing region, or any combination thereof, which can be helpful in controlling different mechanisms and/or stages of thrombus formation. In some alternative embodiments however, the bioactive agent is incorporated into the device proximal to the membrane system, such that the bioactive agent diffuses through the membrane system to the host circulatory system.

**[0354]** The bioactive agent can include a carrier matrix, wherein the matrix includes one or more of collagen, a particulate matrix, a resorbable or non-resorbable matrix, a controlled-release matrix, and/or a gel. In some embodiments, the carrier matrix includes a reservoir, wherein a bioactive agent is encapsulated within a microcapsule. The carrier matrix can include a system in which a bioactive agent is physically entrapped within a polymer network. In some embodiments, the bioactive agent is cross-linked with the membrane system, while in others the bioactive agent is sorbed into the membrane system, for example, by adsorption, absorption, or imbibing. The bioactive agent can be deposited in or on the membrane system, for example, by coating, filling, or solvent casting. In certain embodiments, ionic and nonionic surfactants, detergents, micelles, emulsifiers, demulsifiers, stabilizers, aqueous and oleaginous carriers, solvents, preservatives, antioxidants, or buffering agents are used to incorporate the bioactive agent into the membrane system. The bioactive agent can be incorporated into a polymer using techniques such as described above, and the polymer can be used to form the membrane system, coatings on the membrane system, portions of the membrane system, and/or any portion of the sensor system.

**[0355]** The membrane system can be manufactured using techniques known in the art. The bioactive agent can be sorbed into the membrane system, for example, by soaking the membrane system for a length of time (for example, from about an hour or less to about a week or more, preferably from about 4, 8, 12, 16, or 20 hours to about 1, 2, 3, 4, 5, or 7 days).

**[0356]** The bioactive agent can be blended into uncured polymer prior to forming the membrane system. The membrane system is then cured and the bioactive agent thereby cross-linked and/or encapsulated within the polymer that forms the membrane system.

**[0357]** In yet another embodiment, microspheres are used to encapsulate the bioactive agent. The microspheres can be formed of biodegradable polymers, most preferably synthetic polymers or natural polymers such as proteins and polysaccharides. As used herein, the term polymer is used to refer to

both to synthetic polymers and proteins. U.S. Pat. No. 6,281,015, which is incorporated herein by reference in its entirety, discloses some systems and methods that can be used in conjunction with the preferred embodiments. In general, bioactive agents can be incorporated in (1) the polymer matrix forming the microspheres, (2) microparticle(s) surrounded by the polymer which forms the microspheres, (3) a polymer core within a protein microsphere, (4) a polymer coating around a polymer microsphere, (5) mixed in with microspheres aggregated into a larger form, or (6) a combination thereof. Bioactive agents can be incorporated as particulates or by co-dissolving the factors with the polymer. Stabilizers can be incorporated by addition of the stabilizers to the factor solution prior to formation of the microspheres.

**[0358]** The bioactive agent can be incorporated into a hydrogel and coated or otherwise deposited in or on the membrane system. Some hydrogels suitable for use in the preferred embodiments include cross-linked, hydrophilic, three-dimensional polymer networks that are highly permeable to the bioactive agent and are triggered to release the bioactive agent based on a stimulus.

**[0359]** The bioactive agent can be incorporated into the membrane system by solvent casting, wherein a solution including dissolved bioactive agent is disposed on the surface of the membrane system, after which the solvent is removed to form a coating on the membrane surface.

**[0360]** The bioactive agent can be compounded into a plug of material, which is placed within the device, such as is described in U.S. Pat. Nos. 4,506,680 and 5,282,844, which are incorporated herein by reference in their entirety. In some embodiments, it is preferred to dispose the plug beneath a membrane system; in this way, the bioactive agent is controlled by diffusion through the membrane, which provides a mechanism for sustained-release of the bioactive agent in the host.

#### Release of Bioactive Agents

**[0361]** Numerous variables can affect the pharmacokinetics of bioactive agent release. The bioactive agents of the preferred embodiments can be optimized for short- and/or long-term release. In some embodiments, the bioactive agents of the preferred embodiments are designed to aid or overcome factors associated with short-term effects (e.g., acute inflammation and/or thrombosis) of sensor insertion. In some embodiments, the bioactive agents of the preferred embodiments are designed to aid or overcome factors associated with long-term effects, for example, chronic inflammation or build-up of fibrotic tissue and/or plaque material. In some embodiments, the bioactive agents of the preferred embodiments combine short- and long-term release to exploit the benefits of both.

**[0362]** As used herein, “controlled,” “sustained,” or “extended” release of the factors can be continuous or discontinuous, linear or non-linear. This can be accomplished using one or more types of polymer compositions, drug loadings, selections of excipients or degradation enhancers, or other modifications, administered alone, in combination or sequentially to produce the desired effect.

**[0363]** Short-term release of the bioactive agent in the preferred embodiments generally refers to release over a period of from about a few minutes or hours to about 2, 3, 4, 5, 6, or 7 days or more.

#### Loading of Bioactive Agents

**[0364]** The amount of loading of the bioactive agent into the membrane system can depend upon several factors. For example, the bioactive agent dosage and duration can vary with the intended use of the membrane system, for example, the intended length of use of the device and the like; differences among patients in the effective dose of bioactive agent; location and methods of loading the bioactive agent; and release rates associated with bioactive agents and optionally their carrier matrix. Therefore, one skilled in the art will appreciate the variability in the levels of loading the bioactive agent, for the reasons described above.

**[0365]** In some embodiments, wherein the bioactive agent is incorporated into the membrane system without a carrier matrix, the preferred level of loading of the bioactive agent into the membrane system can vary depending upon the nature of the bioactive agent. The level of loading of the bioactive agent is preferably sufficiently high such that a biological effect (e.g., thrombosis prevention) is observed. Above this threshold, bioactive agent can be loaded into the membrane system so as to imbibe up to 100% of the solid portions, cover all accessible surfaces of the membrane, and/or fill up to 100% of the accessible cavity space. Typically, the level of loading (based on the weight of bioactive agent(s), membrane system, and other substances present) is from about 1 ppm or less to about 1000 ppm or more, preferably from about 2, 3, 4, or 5 ppm up to about 10, 25, 50, 75, 100, 200, 300, 400, 500, 600, 700, 800, or 900 ppm. In certain embodiments, the level of loading can be 1 wt. % or less up to about 50 wt. % or more, preferably from about 2, 3, 4, 5, 6, 7, 8, 9, 10, 15, or 20 wt. % up to about 25, 30, 35, 40, or 45 wt. %.

**[0366]** When the bioactive agent is incorporated into the membrane system with a carrier matrix, such as a gel, the gel concentration can be optimized, for example, loaded with one or more test loadings of the bioactive agent. It is generally preferred that the gel contain from about 0.1 or less to about 50 wt. % or more of the bioactive agent(s), preferably from about 0.2, 0.3, 0.4, 0.5, 0.6, 0.7, 0.8, or 0.9 wt. % to about 6, 7, 8, 9, 10, 15, 20, 25, 30, 35, 40, or 45 wt. % or more bioactive agent(s), more preferably from about 1, 2, or 3 wt. % to about 4 or 5 wt. % of the bioactive agent(s). Substances that are not bioactive can also be incorporated into the matrix.

**[0367]** Referring now to microencapsulated bioactive agents, the release of the agents from these polymeric systems generally occur by two different mechanisms. The bioactive agent can be released by diffusion through aqueous filled channels generated in the dosage form by the dissolution of the agent or by voids created by the removal of the polymer solvent or a pore forming agent during the original microencapsulation. Alternatively, release can be enhanced due to the degradation of the encapsulating polymer. With time, the polymer erodes and generates increased porosity and microstructure within the device. This creates additional pathways for release of the bioactive agent.

**[0368]** In some embodiments, the sensor is designed to be bioinert, e.g., by the use of bioinert materials. Bioinert materials do not substantially cause any response from the host. As a result, cells can live adjacent to the material but do not form a bond with it. Bioinert materials include but are not limited to alumina, zirconia, titanium oxide or other bioinert materials generally used in the “catheter/catheterization” art. While not wishing to be bound by theory, it is believed that inclusion of



a bioinert material in or on the sensor can reduce attachment of blood cells or proteins to the sensor, thrombosis or other host reactions to the sensor.

#### Sensor Electronics

**[0369]** The analyte sensor system has electronics, also referred to as a “computer system” that can include hardware, firmware, and/or software that enable measurement and processing of data associated with analyte levels in the host. In one exemplary embodiment, the electronics include a potentiostat, a power source for providing power to the sensor, and other components useful for signal processing. In another exemplary embodiment, the electronics include an RF module for transmitting data from sensor electronics to a receiver remote from the sensor. In another exemplary embodiment, the sensor electronics are wired to a receiver, which records the data and optionally transmits the data to a remote location, such as but not limited to a nurse’s station, for tracking the host’s progress and to alarm the staff if a hypoglycemic episode occurs.

**[0370]** Various components of the electronics of the sensor system can be disposed on or proximal to the analyte sensor, such as but not limited to disposed on the fluid coupler **20** of the system, such as the embodiment shown in FIG. **1A**. In another embodiment, wherein the sensor is integrally formed on the catheter (e.g., see FIG. **2A**) and the electronics are disposed on or proximal to the connector **218**. In some embodiments, only a portion of the electronics (e.g., the potentiostat) is disposed on the device (e.g., proximal to the sensor), while the remaining electronics are disposed remotely from the device, such as on a stand or by the bedside. In a further embodiment, a portion of the electronics can be disposed in a central location, such as a nurse’s station.

**[0371]** In additional embodiments, some or all of the electronics can be in wired or wireless communication with the sensor and/or other portions of the electronics. For example, a potentiostat disposed on the device can be wired to the remaining electronics (e.g., a processor, a recorder, a transmitter, a receiver, etc.), which reside on the bedside. In another example, some portion of the electronics is wirelessly connected to another portion of the electronics, such as by infrared (IR) or RF. In one embodiment, a potentiostat resides on the fluid coupler and is connected to a receiver by RF; accordingly, a battery, RF transmitter, and/or other minimally necessary electronics are provided with the fluid coupler and the receiver includes an RF receiver.

**[0372]** Preferably, the potentiostat is operably connected to the electrode(s) (such as described above), which biases the sensor to enable measurement of a current signal indicative of the analyte concentration in the host (also referred to as the analog portion). In some embodiments, the potentiostat includes a resistor that translates the current into voltage. In some alternative embodiments, a current to frequency converter is provided that is configured to continuously integrate the measured current, for example, using a charge counting device.

**[0373]** In some embodiments, the electronics include an A/D converter that digitizes the analog signal into a digital signal, also referred to as “counts” for processing. Accordingly, the resulting raw data stream in counts, also referred to as raw sensor data, is directly related to the current measured by the potentiostat.

**[0374]** Typically, the electronics include a processor module that includes the central control unit that controls the

processing of the sensor system. In some embodiments, the processor module includes a microprocessor, however a computer system other than a microprocessor can be used to process data as described herein, for example an ASIC can be used for some or all of the sensor’s central processing. The processor typically provides semi-permanent storage of data, for example, storing data such as sensor identifier (ID) and programming to process data streams (for example, programming for data smoothing and/or replacement of signal artifacts such as is described in U.S. Publication No. US-2005-0043598-A1). The processor additionally can be used for the system’s cache memory, for example for temporarily storing recent sensor data. In some embodiments, the processor module comprises memory storage components such as ROM, RAM, dynamic-RAM, static-RAM, non-static RAM, EEPROM, rewritable ROMs, flash memory, and the like.

**[0375]** In some embodiments, the processor module comprises a digital filter, for example, an infinite impulse response (IIR) or finite impulse response (FIR) filter, configured to smooth the raw data stream from the A/D converter. Generally, digital filters are programmed to filter data sampled at a predetermined time interval (also referred to as a sample rate). In some embodiments, wherein the potentiostat is configured to measure the analyte at discrete time intervals, these time intervals determine the sample rate of the digital filter. In some alternative embodiments, wherein the potentiostat is configured to continuously measure the analyte, for example, using a current-to-frequency converter as described above, the processor module can be programmed to request a digital value from the A/D converter at a predetermined time interval, also referred to as the acquisition time. In these alternative embodiments, the values obtained by the processor are advantageously averaged over the acquisition time due to the continuity of the current measurement. Accordingly, the acquisition time determines the sample rate of the digital filter. In preferred embodiments, the processor module is configured with a programmable acquisition time, namely, the predetermined time interval for requesting the digital value from the A/D converter is programmable by a user within the digital circuitry of the processor module. An acquisition time of from about 2 seconds to about 512 seconds is preferred; however any acquisition time can be programmed into the processor module. A programmable acquisition time is advantageous in optimizing noise filtration, time lag, and processing/battery power.

**[0376]** In some embodiments, the processor module is configured to build the data packet for transmission to an outside source, for example, an RF transmission to a receiver. Generally, the data packet comprises a plurality of bits that can include a preamble, a unique identifier identifying the electronics unit, the receiver, or both, (e.g., sensor ID code), data (e.g., raw data, filtered data, and/or an integrated value) and/or error detection or correction. Preferably, the data (transmission) packet has a length of from about 8 bits to about 128 bits, preferably about 48 bits; however, larger or smaller packets can be desirable in certain embodiments. The processor module can be configured to transmit any combination of raw and/or filtered data. In one exemplary embodiment, the transmission packet contains a fixed preamble, a unique ID of the electronics unit, a single five-minute average (e.g., integrated) sensor data value, and a cyclic redundancy code (CRC).

**[0377]** In some embodiments, the processor module further comprises a transmitter portion that determines the transmis-

sion interval of the sensor data to a receiver, and the like. In some embodiments, the transmitter portion, which determines the interval of transmission, is configured to be programmable. In one such embodiment, a coefficient can be chosen (e.g., a number of from about 1 to about 100, or more), wherein the coefficient is multiplied by the acquisition time (or sampling rate), such as described above, to define the transmission interval of the data packet. Thus, in some embodiments, the transmission interval is programmable from about 2 seconds to about 850 minutes, more preferably from about 30 second to about 5 minutes; however, any transmission interval can be programmable or programmed into the processor module. However, a variety of alternative systems and methods for providing a programmable transmission interval can also be employed. By providing a programmable transmission interval, data transmission can be customized to meet a variety of design criteria (e.g., reduced battery consumption, timeliness of reporting sensor values, etc.)

**[0378]** In some embodiments, the processor further performs the processing, such as storing data, analyzing data streams, calibrating analyte sensor data, estimating analyte values, comparing estimated analyte values with time corresponding measured analyte values, analyzing a variation of estimated analyte values, downloading data, and controlling the user interface by providing analyte values, prompts, messages, warnings, alarms, and the like. In such cases, the processor includes hardware and software that performs the processing described herein, for example flash memory provides permanent or semi-permanent storage of data, storing data such as sensor ID, receiver ID, and programming to process data streams (for example, programming for performing estimation and other algorithms described elsewhere herein) and random access memory (RAM) stores the system's cache memory and is helpful in data processing. Alternatively, some portion of the data processing (such as described with reference to the processor elsewhere herein) can be accomplished at another (e.g., remote) processor and can be configured to be in wired or wireless connection therewith.

**[0379]** In some embodiments, an output module, which is integral with and/or operatively connected with the processor, includes programming for generating output based on the data stream received from the sensor system and its processing incurred in the processor. In some embodiments, output is generated via a user interface.

**[0380]** In some embodiments, a user interface is provided integral with (e.g., on the patient inserted medical device), proximal to (e.g., a receiver near the medical device including bedside or on a stand), or remote from the sensor electronics (e.g., at a central station such as a nurse's station), wherein the user interface comprises a keyboard, speaker, vibrator, backlight, liquid crystal display (LCD) screen, and one or more buttons. The components that comprise the user interface include controls to allow interaction of the user with the sensor system. The keyboard can allow, for example, input of user information, such as mealtime, exercise, insulin administration, customized therapy recommendations, and reference analyte values. The speaker can produce, for example, audible signals or alerts for conditions such as present and/or estimated hyperglycemic or hypoglycemic conditions. The vibrator can provide, for example, tactile signals or alerts for reasons such as described with reference to the speaker, above. The backlight can be provided, for example, to aid a user in reading the LCD in low light conditions. The LCD can

be provided, for example, to provide the user with visual data output, such as is described in U.S. Publication No. US-2005-0203360-A1. In some embodiments, the LCD is a touch-activated screen, enabling each selection by a user, for example, from a menu on the screen. The buttons can provide for toggle, menu selection, option selection, mode selection, and reset, for example. In some alternative embodiments, a microphone can be provided to allow for voice-activated control.

**[0381]** In some embodiments, prompts or messages can be displayed on the user interface to convey information to the user, such as reference outlier values, requests for reference analyte values, therapy recommendations, deviation of the measured analyte values from the estimated analyte values, and the like. Additionally, prompts can be displayed to guide the user through calibration or trouble-shooting of the calibration.

**[0382]** Additionally, data output from the output module can provide wired or wireless, one- or two-way communication between the user interface and an external device. The external device can be any device that wherein interfaces or communicates with the user interface. In some embodiments, the external device is a computer, and the system is able to download historical data for retrospective analysis by the patient or physician, for example. In some embodiments, the external device is a modem or other telecommunications station, and the system is able to send alerts, warnings, emergency messages, and the like, via telecommunication lines to another party, such as a doctor or family member. In some embodiments, the external device is an insulin pen, and the system is able to communicate therapy recommendations, such as insulin amount and time to the insulin pen. In some embodiments, the external device is an insulin pump, and the system is able to communicate therapy recommendations, such as insulin amount and time to the insulin pump. The external device can include other technology or medical devices, for example pacemakers, implanted analyte sensor patches, other infusion devices, telemetry devices, and the like.

**[0383]** The user interface, including keyboard, buttons, a microphone (not shown), and optionally the external device, can be configured to allow input of data. Data input can be helpful in obtaining information about the patient (for example, meal time, insulin administration, and the like), receiving instructions from a physician (for example, customized therapy recommendations, targets, and the like), and downloading software updates, for example. Keyboard, buttons, touch-screen, and microphone are all examples of mechanisms by which a user can input data directly into the receiver. A server, personal computer, personal digital assistant, insulin pump, and insulin pen are examples of external devices that can provide useful information to the receiver. Other devices internal or external to the sensor that measure other aspects of a patient's body (for example, temperature sensor, accelerometer, heart rate monitor, oxygen monitor, and the like) can be used to provide input helpful in data processing. In one embodiment, the user interface can prompt the patient to select an activity most closely related to their present activity, such as medication taken, surgical procedures, and the like, which can be helpful in linking to an individual's physiological patterns, or other data processing. In another embodiment, a temperature sensor and/or heart rate monitor can provide information helpful in linking activity, metabolism, and glucose excursions of an individual.

While a few examples of data input have been provided here, a variety of information can be input, which can be helpful in data processing.

#### Algorithms

**[0384]** In some embodiments, calibration of an analyte sensor can be required, which includes data processing that converts sensor data signal into an estimated analyte measurement that is meaningful to a user. In general, the sensor system has a computer system (e.g., within the electronics) that receives sensor data (e.g., a data stream), including one or more time-spaced sensor data points, measured by the sensor. The sensor data point(s) can be smoothed (filtered) in certain embodiments using a filter, for example, a finite impulse response (FIR) or infinite impulse response (IIR) filter. During the initialization of the sensor, prior to initial calibration, the system can receive and store uncalibrated sensor data, however it can be configured to not display any data to the user until initial calibration and, optionally, stabilization of the sensor has been established. In some embodiments, the data stream can be evaluated to determine sensor break-in (equilibration of the sensor *in vitro* or *in vivo*).

**[0385]** In some embodiments, the system is configured to receive reference data from a reference analyte monitor, including one or more reference data points, also referred to as calibration information in some embodiments. The monitor can be of any suitable configuration. For example, in one embodiment, the reference analyte points can comprise results from a self-monitored blood analyte test (e.g., from a finger stick test), such as those described in U.S. Pat. Nos. 6,045,567; 6,156,051; 6,197,040; 6,284,125; 6,413,410; and 6,733,655. In one such embodiment, the user can administer a self-monitored blood analyte test to obtain an analyte value (e.g., point) using any suitable analyte sensor, and then enter the numeric analyte value into the computer system. In another such embodiment, a self-monitored blood analyte test comprises a wired or wireless connection to the computer system so that the user simply initiates a connection between the two devices, and the reference analyte data is passed or downloaded between the self-monitored blood analyte test and the system. In yet another such embodiment, the self-monitored analyte test is integral with the receiver so that the user simply provides a blood sample to the receiver, and the receiver runs the analyte test to determine a reference analyte value.

**[0386]** In some alternative embodiments, the reference data is based on sensor data from another substantially continuous analyte sensor such as described herein, or another type of suitable continuous analyte sensor. In an embodiment employing a series of two or more continuous sensors, the sensors can be employed so that they provide sensor data in discrete or overlapping periods. In such embodiments, the sensor data from one continuous sensor can be used to calibrate another continuous sensor, or be used to confirm the validity of a subsequently employed continuous sensor.

**[0387]** In some embodiments, the sensor system is coupled to a blood analysis device that periodically or intermittently collects a sample of the host's blood (e.g., through the sensor system) and measures the host's glucose concentration. In some embodiments, the blood analysis device collects a blood sample from the host about every 30 minutes, every hour, or every few hours (e.g., 2, 3, 4, 5, 6, 8, 9 or 10 hours or longer). In other embodiments, the blood analysis device can be activated manually (e.g., by a healthcare worker) to collect

and analyze a blood sample from the host. The glucose concentration data generated by the blood analysis device can be used by the sensor system for calibration data. In some embodiments, the sensor system can electronically receive (either wired or wirelessly) these calibration data (from the blood analysis device). In other embodiments, these calibration data can be entered into the sensor system (e.g., sensor system electronics) by hand (e.g., manually entered by a healthcare worker).

**[0388]** In some embodiments, the sensor system is provided with one or more calibration solutions (e.g., glucose solutions). In some embodiments, the sensor is shipped in a calibration solution (e.g., soaked). The sensor is activated to calibrate itself (using the calibration solution in which it was shipped) before insertion into the host. In some embodiments, the sensor is shipped (e.g., soaked or dry) with one or more vials of calibration solution. The sensor can be soaked (e.g., sequentially) in the vial(s) of calibration solution; calibration data points collected and the sensor calibrated using those calibration points, before inserting the sensor into the host.

**[0389]** In one exemplary embodiment, the sensor is a glucose sensor, and it is shipped soaking in a sterile 50-mg/dl glucose solution with two accompanying calibration solutions (e.g., 100-mg/dl and 200-mg/dl sterile glucose solutions). Prior to insertion into the host, calibration data points are collected with the sensor in the 50-mg/dl, 100-mg/dl and 200-mg/dl glucose solutions respectively. The sensor system can be calibrated using the collected calibration data points (e.g., using regression as described in more detail elsewhere herein). In an alternative exemplary embodiment, the sensor is shipped dry (e.g., not soaking in a solution or buffer) with at least one calibration solution, for calibrating the sensor prior to insertion into the host. In some embodiments, a hand held glucose monitor (e.g., SMBG device described herein) can test the calibration solutions to generate calibration data points, which are transferred electronically or manually to the sensor system for calibration.

**[0390]** In some embodiments, a data matching module, also referred to as the processor module, matches reference data (e.g., one or more reference analyte data points) with substantially time corresponding sensor data (e.g., one or more sensor data points) to provide one or more matched data pairs. One reference data point can be matched to one time corresponding sensor data point to form a matched data pair. Alternatively, a plurality of reference data points can be averaged (e.g., equally or non-equally weighted average, mean-value, median, and the like) and matched to one time corresponding sensor data point to form a matched data pair, one reference data point can be matched to a plurality of time corresponding sensor data points averaged to form a matched data pair, or a plurality of reference data points can be averaged and matched to a plurality of time corresponding sensor data points averaged to form a matched data pair.

**[0391]** In some embodiments, a calibration set module, also referred to as the calibration module or processor module, forms an initial calibration set from a set of one or more matched data pairs, which are used to determine the relationship between the reference analyte data and the sensor analyte data. The matched data pairs, which make up the initial calibration set, can be selected according to predetermined criteria. The criteria for the initial calibration set can be the same as, or different from, the criteria for the updated calibration sets. In certain embodiments, the number (n) of data pair(s) selected for the initial calibration set is one. In other embodi-

ments,  $n$  data pairs are selected for the initial calibration set wherein  $n$  is a function of the frequency of the received reference data points. In various embodiments, two data pairs make up the initial calibration set or six data pairs make up the initial calibration set. In an embodiment wherein a substantially continuous analyte sensor provides reference data, numerous data points are used to provide reference data from more than 6 data pairs (e.g., dozens or even hundreds of data pairs). In one exemplary embodiment, a substantially continuous analyte sensor provides 288 reference data points per day (every five minutes for twenty-four hours), thereby providing an opportunity for a matched data pair 288 times per day, for example. While specific numbers of matched data pairs are referred to in the preferred embodiments, any suitable number of matched data pairs per a given time period can be employed.

**[0392]** In some embodiments, a conversion function module, also referred to as the conversion module or processor module, uses the calibration set to create a conversion function. The conversion function substantially defines the relationship between the reference analyte data and the analyte sensor data.

**[0393]** A variety of known methods can be used with the preferred embodiments to create the conversion function from the calibration set. In one embodiment, wherein a plurality of matched data points form the calibration set, a linear least squares regression is used to calculate the conversion function; for example, this regression calculates a slope and an offset using the equation  $y=mx+b$ . A variety of regression or other conversion schemes can be implemented herein.

**[0394]** In some alternative embodiments, the sensor is a dual-electrode system. In one such dual-electrode system, a first electrode functions as a hydrogen peroxide sensor including a membrane system containing glucose-oxidase disposed thereon, which operates as described herein. A second electrode is a hydrogen peroxide sensor that is configured similar to the first electrode, but with a modified membrane system (with the enzyme domain removed, for example). This second electrode provides a signal composed mostly of the baseline signal,  $b$ .

**[0395]** In some dual-electrode systems, the baseline signal is (electronically or digitally) subtracted from the glucose signal to obtain a glucose signal substantially without baseline. Accordingly, calibration of the resultant difference signal can be performed by solving the equation  $y=mx$  with a single paired measurement. Calibration of the implanted sensor in this alternative embodiment can be made less dependent on the values/range of the paired measurements, less sensitive to error in manual blood glucose measurements, and can facilitate the sensor's use as a primary source of glucose information for the user. U.S. Publication No. US-2005-0143635-A1 describes systems and methods for subtracting the baseline from a sensor signal.

**[0396]** In some alternative dual-electrode system embodiments, the analyte sensor is configured to transmit signals obtained from each electrode separately (e.g., without subtraction of the baseline signal). In this way, the receiver can process these signals to determine additional information about the sensor and/or analyte concentration. For example, by comparing the signals from the first and second electrodes, changes in baseline and/or sensitivity can be detected and/or measured and used to update calibration (e.g., without the use of a reference analyte value). In one such example, by monitoring the corresponding first and second signals over time, an

amount of signal contributed by baseline can be measured. In another such example, by comparing fluctuations in the correlating signals over time, changes in sensitivity can be detected and/or measured.

**[0397]** In some alternative embodiments, a regression equation  $y=mx+b$  is used to calculate the conversion function; however, prior information can be provided for  $m$  and/or  $b$ , thereby enabling calibration to occur with fewer paired measurements. In one calibration technique, prior information (e.g., obtained from in vivo or in vitro tests) determines a sensitivity of the sensor and/or the baseline signal of the sensor by analyzing sensor data from measurements taken by the sensor (e.g., prior to inserting the sensor). For example, if there exists a predictive relationship between in vitro sensor parameters and in vivo parameters, then this information can be used by the calibration procedure. For example, if a predictive relationship exists between in vitro sensitivity and in vivo sensitivity,  $m \approx f(m_{in\ vitro})$ , then the predicted  $m$  can be used, along with a single matched pair, to solve for  $b$  ( $b=y-mx$ ). If, in addition,  $b$  can be assumed  $=0$ , for example with a dual-electrode configuration that enables subtraction of the baseline from the signal such as described above, then both  $m$  and  $b$  are known a priori, matched pairs are not needed for calibration, and the sensor can be completely calibrated e.g. without the need for reference analyte values (e.g. values obtained after implantation in vivo.)

**[0398]** In another alternative embodiment, prior information can be provided to guide or validate the baseline ( $b$ ) and/or sensitivity ( $m$ ) determined from the regression analysis. In this embodiment, boundaries can be set for the regression line that defines the conversion function such that working sensors are calibrated accurately and easily (with two points), and non-working sensors are prevented from being calibrated. If the boundaries are drawn too tightly, a working sensor may not enter into calibration. Likewise, if the boundaries are drawn too loosely, the scheme can result in inaccurate calibration or can permit non-working sensors to enter into calibration. For example, subsequent to performing regression, the resulting slope and/or baseline are tested to determine whether they fall within a predetermined acceptable threshold (boundaries). These predetermined acceptable boundaries can be obtained from in vivo or in vitro tests (e.g., by a retrospective analysis of sensor sensitivities and/or baselines collected from a set of sensors/patients, assuming that the set is representative of future data).

**[0399]** In some alternative embodiments, the sensor system does not require initial and/or update calibration by the host; in these alternative embodiments, also referred to as "zero-point calibration" embodiments, use of the sensor system without requiring a reference analyte measurement for initial and/or update calibration is enabled. In general, the systems and methods of the preferred embodiments provide for stable and repeatable sensor manufacture, particularly when tightly controlled manufacturing processes are utilized. Namely, a batch of sensors of the preferred embodiments can be designed with substantially the same baseline ( $b$ ) and/or sensitivity ( $m$ ) ( $\pm 10\%$ ) when tested in vitro. Additionally, the sensor of the preferred embodiments can be designed for repeatable  $m$  and  $b$  in vivo. Thus, an initial calibration factor (conversion function) can be programmed into the sensor (sensor electronics and/or receiver electronics) that enables conversion of raw sensor data into calibrated sensor data solely using information obtained prior to implantation (namely, initial calibration does not require a reference ana-

lyte value). Additionally, to obviate the need for recalibration (update calibration) during the life of the sensor, the sensor is designed to minimize drift of the sensitivity and/or baseline over time in vivo. Accordingly, the preferred embodiments can be manufactured for zero point calibration.

**[0400]** In some embodiments, a sensor data transformation module, also referred to as the calibration module, conversion module, or processor module, uses the conversion function to transform sensor data into substantially real-time analyte value estimates, also referred to as calibrated data, or converted sensor data, as sensor data is continuously (or intermittently) received from the sensor. For example, the sensor data, which can be provided to the receiver in “counts,” is translated in to estimate analyte value(s) in mg/dL. In other words, the offset value at any given point in time can be subtracted from the raw value (e.g., in counts) and divided by the slope to obtain the estimate analyte value:

$$\text{mg/dL} = \frac{(\text{rawvalue} - \text{offset})}{\text{slope}}$$

**[0401]** In some embodiments, an output module provides output to the user via the user interface. The output is representative of the estimated analyte value, which is determined by converting the sensor data into a meaningful analyte value. User output can be in the form of a numeric estimated analyte value, an indication of directional trend of analyte concentration, and/or a graphical representation of the estimated analyte data over a period of time, for example. Other representations of the estimated analyte values are also possible, for example audio and tactile.

**[0402]** In some embodiments, annotations are provided on the graph; for example, bitmap images are displayed thereon, which represent events experienced by the host. For example, information about meals, medications, insulin, exercise, sensor insertion, sleep, and the like, can be obtained by the receiver (by user input or receipt of a transmission from another device) and displayed on the graphical representation of the host’s glucose over time. It is believed that illustrating a host’s life events matched with a host’s glucose concentration over time can be helpful in educating the host to his or her metabolic response to the various events.

**[0403]** In yet another alternative embodiment, the sensor utilizes one or more additional electrodes to measure an additional analyte. Such measurements can provide a baseline or sensitivity measurement for use in calibrating the sensor. Furthermore, baseline and/or sensitivity measurements can be used to trigger events such as digital filtering of data or suspending display of data, all of which are described in more detail in U.S. Publication No. US-2005-0143635-A1.

**[0404]** In one exemplary embodiment, the sensor can be calibrated by a calibration solution. For example, after the sensor system has been inserted into the host, a calibration solution can be injected so as to pass across the electroactive surface of the analyte-measuring electrode and the sensor calibrated thereby. For example, the saline drip can be changed to a known IV glucose or dextrose solution (e.g., D50—a 50% dextrose solution, or D5W—a 5% dextrose solution). In one embodiment, a known volume of D5W is infused into the host at a known rate over a predetermined period of time (e.g., 5, 10, 15 or 20 minutes, or for shorter or longer periods). During and/or after the period of infusion, the sensor measures the signal at the analyte-measuring

working electrode. The system, knowing the specifications of the infused calibration solution (also referred to as a calibration information in some embodiments), can calibrate the signal to obtain host’s glucose concentration as is appreciated by one skilled in the art. In a further embodiment, two or more glucose or dextrose solutions can be infused, with a corresponding signal being measured during each infusion, to provide additional data for sensor calibration. Calibration can be performed after the sensor has first been inserted into the host, after a break-in time, at two or more different levels (high/low), regularly, intermittently, in response to sensor drift/shift, automatically or any other time when calibration is required.

**[0405]** In some circumstances, catheters are flushed with saline. For example, the analyte sensor system of the preferred embodiments can be flushed with saline prior to application of control solutions, after which a predetermined amount of glucose solution is flushed by the sensor, as described above, and the sensor is calibrated there from.

**[0406]** In still another embodiment, a blood sample can be withdrawn from an artery or vein, and used to calibrate the sensor, for example, by using a hand-held glucose meter, by an automatic extracorporeal glucose sensor such as but not limited to in conjunction with an automated bedside clinical chemistry device, or by sending the blood sample to the clinical laboratory for glucose analysis, after which the data is input (e.g., into the electronics associated with the sensor system).

**[0407]** In some embodiments, the sensor can be calibrated (and/or re-calibrated) during use (after initial calibration), for example, by withdrawing one or more blood samples (also referred to as calibration information in some embodiments), through the catheter (see FIGS. 1 and 2) and used for calibration of the sensor, such as by measuring the glucose concentration of the blood sample with an additional system, such as but not limited to a hand-held glucose meter, optical methods or additional electrochemical methods. Blood samples can be withdrawn manually or automatically; additionally or alternatively, blood samples are withdrawn at regular intervals or at selected times, for example, using an extracorporeal blood analysis device as described herein.

**[0408]** In another embodiment of sensor calibration (and/or re-calibration) during use, a calibration solution (e.g., 40 mg/dL equivalent glucose, D540 or D5W) can be flushed through or by the sensor to enable calibration of the sensor (e.g., at one time, intermittently, or continuously), such as described in more detail above. In these embodiments, calibration solution can be flushed manually or automatically through the system; additionally or alternatively, calibration solution can be flushed at regular intervals or at selected times. In one exemplary embodiment, the system can be provided with a dual lumen, one for saline and another for the control solution. Additionally, the system is configured to automatically switch from the saline to control solution and perform the real-time system calibration, and then switch back to the saline solution.

## EXAMPLES

### Example 1

#### Glucose Sensor System Trial in Dogs

**[0409]** Glucose Sensor Systems of the Embodiment Shown in FIG. 1 were Tested in dogs. The glucose sensors were built

according to the preferred embodiments described herein. Namely, a first sensor (Test 1) was built by providing a platinum wire, vapor-depositing the platinum with Parylene to form an insulating coating, helically winding a silver wire around the insulated platinum wire (to form a “twisted pair”), masking sections of the electroactive surface of the silver wire, vapor-depositing Parylene on the twisted pair, chloridizing the silver electrode to form a silver chloride reference electrode, and removing a radial window on the insulated platinum wire to expose a circumferential electroactive working electrode surface area thereon, this assembly also referred to as a “parylene-coated twisted pair assembly.”

**[0410]** An electrode domain was formed over the electroactive surface areas of the working and reference electrodes by dip coating the assembly in an electrode solution (comprising BAYHYDROL® 123, an aliphatic polycarbonate urethane resin) and drying. An enzyme domain was formed over the electrode domain by subsequently dip coating the assembly in an enzyme solution (comprising BAYHYDROL® 140AQ, an aliphatic polyester urethane resin, and glucose oxidase) and drying. A resistance domain was formed over the enzyme domain by spraying the resistance domain solution (comprising a blend of CHRONOTHANE®-1020 (a polyetherurethaneurea based on polytetramethylene glycol, methylene diisocyanate and organic amines) and CHRONOTHANE®-H (a polyetherurethaneurea based on polytetramethylene glycol, polyethylene glycol, methylene diisocyanate, and organic amines)) on the sensor construct.

**[0411]** After the sensor was constructed, it was placed in the protective sheath and then threaded through and attached to the fluid coupler.

**[0412]** A second sensor (Test 2) was constructed in the same manner as the first, except that the silver wire was disposed within (e.g., coiled within) the fluid coupler. Accordingly, only the platinum working electrode (a single wire) was inserted into the catheter during the experiment.

**[0413]** Prior to use, the sensors were sterilized using electron beam.

**[0414]** The forelimb of an anesthetized dog (2 years old, ~40 pounds) was cut down to the femoral artery and vein. An arterio-venous shunt was placed from the femoral artery to the femoral vein using 14 gauge catheters and 1/8-inch IV tubing. A pressurized arterial fluid line was connected to the sensor systems at all times. The test sensor systems (test 1 and test 2) included a 20 gauge x 1.25-inch catheter and took measurements every 30 seconds. The catheter was aseptically inserted into the shunt, followed by insertion of the sensor into the catheter. A transcutaneous glucose sensor (control) of the type disclosed in U.S. Publ. No. US-2006-0155180-A1 was built and placed in the dog’s abdomen according to recommended procedures. The dog was challenged with continuous incremental IV infusion of a 10% dextrose solution (“glucose challenge”) until the blood glucose concentration reached about 400 mg/dL.

**[0415]** FIG. 4 shows the experimental results. The thick line represents data collected from the Test 1 sensor. The thin line represents data collected from the Test 2 sensor. Diamonds represent data collected from a hand-held blood glucose meter (SMBG) sampled from the dog’s abdomen. Raw glucose test data (counts) are shown on the left-hand Y-axis, glucose concentrations for the “SMBG” controls are shown on the right-hand y-axis, and time is shown on the X-axis. Each time interval on the X-axis represents 29-minutes (e.g., 10:04 to 10:33 equals 29 minutes). Immediately upon inser-

tion into a catheter, each test sensor began collecting data with substantially no sensor equilibration time (e.g., break-in time). Each test sensor responded to the glucose challenge substantially similarly to the control sensor. For example, each device shows the glucose signal increasing from about 3200 counts at 10:33 to about 6000-6700 counts at 11:31. Then, each device showed a rapid decrease in glucose signal, to about 4700 counts at 12:00. Additionally, the response of the test sensors and the control sensor were substantially similar (e.g., the majority of the test data was substantially equivalent to the SMBG data at each time point). From these experimental show that an indwelling glucose sensor system (as described herein) in contact with the circulatory system can provide substantially continuous glucose monitoring in a clinical setting.

#### Example 2

##### Glucose Sensor System Trial in Pigs

**[0416]** Four glucose sensor systems of the embodiment shown in FIG. 1 were tested in a pig (~104 lb), using the protocol described for Example 1, above. Glucose was continuously infused at increasing rates through a distally placed IV catheter until a readout of 300-400 mg/dl blood glucose was achieved (total 300-ml of a 10% dextrose IV solution). FIG. 5 shows the experimental results. Lines indicated the data from the four sensors (Test 1 through Test 4). Diamonds represent control measurements made with a hand-held glucose meter (SMBG). Raw glucose test data (counts) are shown on the left-hand Y-axis, glucose concentrations for the “SMBG” controls are shown on the right-hand y-axis, and time is shown on the X-axis. Test results show that though the sensors varied in sensitivity, each test sensor responded to glucose challenge substantially similarly to the control sensor (SMBG). These experimental results show that an indwelling glucose sensor system (of the preferred embodiments) in contact with the circulatory system can substantially continuously track glucose in a clinical setting.

**[0417]** Methods and devices that are suitable for use in conjunction with aspects of the preferred embodiments are disclosed in U.S. Pat. No. 4,994,167; U.S. Pat. No. 4,757,022; U.S. Pat. No. 6,001,067; U.S. Pat. No. 6,741,877; U.S. Pat. No. 6,702,857; U.S. Pat. No. 6,558,321; U.S. Pat. No. 6,931,327; U.S. Pat. No. 6,862,465; U.S. Pat. No. 7,074,307; U.S. Pat. No. 7,081,195; U.S. Pat. No. 7,108,778; and U.S. Pat. No. 7,110,803.

**[0418]** Methods and devices that are suitable for use in conjunction with aspects of the preferred embodiments are disclosed in U.S. Publication No. US-2005-0176136-A1; U.S. Publication No. US-2005-0251083-A1; U.S. Publication No. US-2005-0143635-A1; U.S. Publication No. US-2005-0181012-A1; U.S. Publication No. US-2005-0177036-A1; U.S. Publication No. US-2005-0124873-A1; U.S. Publication No. US-2005-0115832-A1; U.S. Publication No. US-2005-0245799-A1; U.S. Publication No. US-2005-0245795-A1; U.S. Publication No. US-2005-0242479-A1; U.S. Publication No. US-2005-0182451-A1; U.S. Publication No. US-2005-0056552-A1; U.S. Publication No. US-2005-0192557-A1; U.S. Publication No. US-2005-0154271-A1; U.S. Publication No. US-2004-0199059-A1; U.S. Publication No. US-2005-0054909-A1; U.S. Publication No. US-2005-0112169-A1; U.S. Publication No. US-2005-0051427-A1; U.S. Publication No. US-2003-0032874-A1; U.S. Publication No. US-2005-

0103625-A1; U.S. Publication No. US-2005-0203360-A1; U.S. Publication No. US-2005-0090607-A1; U.S. Publication No. US-2005-0187720-A1; U.S. Publication No. US-2005-0161346-A1; U.S. Publication No. US-2006-0015020-A1; U.S. Publication No. US-2005-0043598-A1; U.S. Publication No. US-2003-0217966-A1; U.S. Publication No. US-2005-0033132-A1; U.S. Publication No. US-2005-0031689-A1; U.S. Publication No. US-2004-0186362-A1; U.S. Publication No. US-2005-0027463-A1; U.S. Publication No. US-2005-0027181-A1; U.S. Publication No. US-2005-0027180-A1; U.S. Publication No. US-2006-0020187-A1; U.S. Publication No. US-2006-0036142-A1; U.S. Publication No. US-2006-0020192-A1; U.S. Publication No. US-2006-0036143-A1; U.S. Publication No. US-2006-0036140-A1; U.S. Publication No. US-2006-0019327-A1; U.S. Publication No. US-2006-0020186-A1; U.S. Publication No. US-2006-0020189-A1; U.S. Publication No. US-2006-0036139-A1; U.S. Publication No. US-2006-0020191-A1; U.S. Publication No. US-2006-0020188-A1; U.S. Publication No. US-2006-0036141-A1; U.S. Publication No. US-2006-0020190-A1; U.S. Publication No. US-2006-0036145-A1; U.S. Publication No. US-2006-0036144-A1; U.S. Publication No. US-2006-0016700-A1; U.S. Publication No. US-2006-0142651-A1; U.S. Publication No. US-2006-0086624-A1; U.S. Publication No. US-2006-0068208-A1; U.S. Publication No. US-2006-0040402-A1; U.S. Publication No. US-2006-0036142-A1; U.S. Publication No. US-2006-0036141-A1; U.S. Publication No. US-2006-0036143-A1; U.S. Publication No. US-2006-0036140-A1; U.S. Publication No. US-2006-0036139-A1; U.S. Publication No. US-2006-0142651-A1; U.S. Publication No. US-2006-0036145-A1; U.S. Publication No. US-2006-0200022-A1; U.S. Publication No. US-2006-0198864-A1; U.S. Publication No. US-2006-0200019-A1; U.S. Publication No. US-2006-0189856-A1; U.S. Publication No. US-2006-0200020-A1; U.S. Publication No. US-2006-0200970-A1; U.S. Publication No. US-2006-0183984-A1; U.S. Publication No. US-2006-0183985-A1; and U.S. Publication No. US-2006-0195029-A1.

**[0419]** Methods and devices that are suitable for use in conjunction with aspects of the preferred embodiments are disclosed in U.S. application Ser. No. 09/447,227 filed Nov. 22, 1999 and entitled “DEVICE AND METHOD FOR DETERMINING ANALYTE LEVELS”; U.S. application Ser. No. 11/335,879 filed Jan. 18, 2006 and entitled “CELLULOSE-BASED INTERFERENCE DOMAIN FOR AN ANALYTE SENSOR”; U.S. application Ser. No. 11/334,876 filed Jan. 18, 2006 and entitled “TRANSCUTANEOUS ANALYTE SENSOR”; U.S. application Ser. No. 11/498,410 filed Aug. 2, 2006 and entitled “SYSTEMS AND METHODS FOR REPLACING SIGNAL ARTIFACTS IN A GLUCOSE SENSOR DATA STREAM”; U.S. application Ser. No. 11/515,443 filed Sep. 1, 2006 and entitled “SYSTEMS AND METHODS FOR PROCESSING ANALYTE SENSOR DATA”; U.S. application Ser. No. 11/503,367 filed Aug. 10, 2006 and entitled “ANALYTE SENSOR”; and U.S. application Ser. No. 11/515,342 filed Sep. 1, 2006 and entitled “SYSTEMS AND METHODS FOR PROCESSING ANALYTE SENSOR DATA”.

**[0420]** All references cited herein, including but not limited to published and unpublished applications, patents, and literature references, are incorporated herein by reference in

their entirety and are hereby made a part of this specification. To the extent publications and patents or patent applications incorporated by reference contradict the disclosure contained in the specification, the specification is intended to supersede and/or take precedence over any such contradictory material.

**[0421]** The term “comprising” as used herein is synonymous with “including,” “containing,” or “characterized by;” and is inclusive or open-ended and does not exclude additional, unrecited elements or method steps.

**[0422]** All numbers expressing quantities of ingredients, reaction conditions, and so forth used in the specification are to be understood as being modified in all instances by the term “about.” Accordingly, unless indicated to the contrary, the numerical parameters set forth herein are approximations that may vary depending upon the desired properties sought to be obtained. At the very least, and not as an attempt to limit the application of the doctrine of equivalents to the scope of any claims in any application claiming priority to the present application, each numerical parameter should be construed in light of the number of significant digits and ordinary rounding approaches.

**[0423]** The above description discloses several methods and materials of the present invention. This invention is susceptible to modifications in the methods and materials, as well as alterations in the fabrication methods and equipment. Such modifications will become apparent to those skilled in the art from a consideration of this disclosure or practice of the invention disclosed herein. Consequently, it is not intended that this invention be limited to the specific embodiments disclosed herein, but that it cover all modifications and alternatives coming within the true scope and spirit of the invention.

What is claimed is:

1. A system for measuring glucose in a host and delivering medication to the host, the system comprising:
  - a catheter configured for insertion into a host and configured to deliver medication to the host, wherein the catheter comprises an exterior surface;
  - a continuous glucose sensor disposed at least partially on the exterior surface of the catheter, wherein the continuous glucose sensor is configured to generate sensor data indicative of glucose concentration; and
  - sensor electronics operatively connected to the continuous glucose sensor, wherein the sensor electronics are configured to determine a glucose concentration.
2. The system of claim 1, wherein the continuous glucose sensor is integrally formed on the exterior surface of the catheter.
3. The system of claim 1, wherein the continuous glucose sensor is electroplated onto the exterior surface of the catheter.
4. The system of claim 1, wherein the continuous glucose sensor comprises a working electrode and a membrane system covering at least a portion of the working electrode.
5. The system of claim 1, wherein the working electrode comprises an exposed electroactive surface.
6. The system of claim 1, wherein the catheter is configured to be operatively connected to an infusion pump.
7. The system of claim 1, wherein in response to sensor data received from the continuous glucose sensor, the sensor electronics are configured to communicate a therapy recommendation to the infusion pump, wherein the therapy recommendation comprises information relating to insulin amount.

8. The system of claim 1, wherein the continuous glucose sensor is configured to be used subcutaneously.

9. The system of claim 1, wherein the sensor electronics are configured to substantially continuously determine the glucose concentration.

\* \* \* \* \*